

(No Model.)

C. TIBBS.
GATE.

No. 403,401.

Patented May 14, 1889.

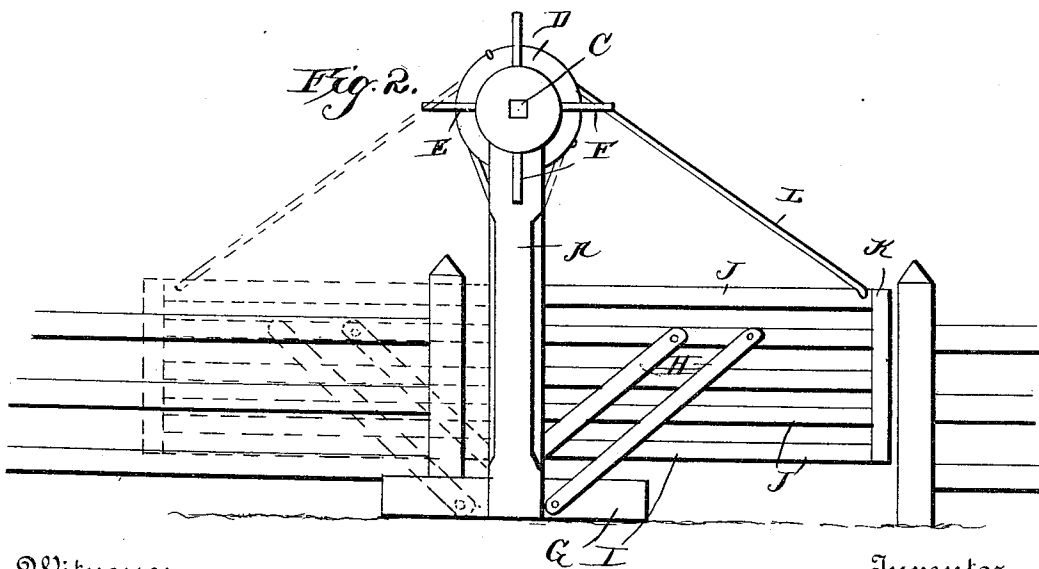
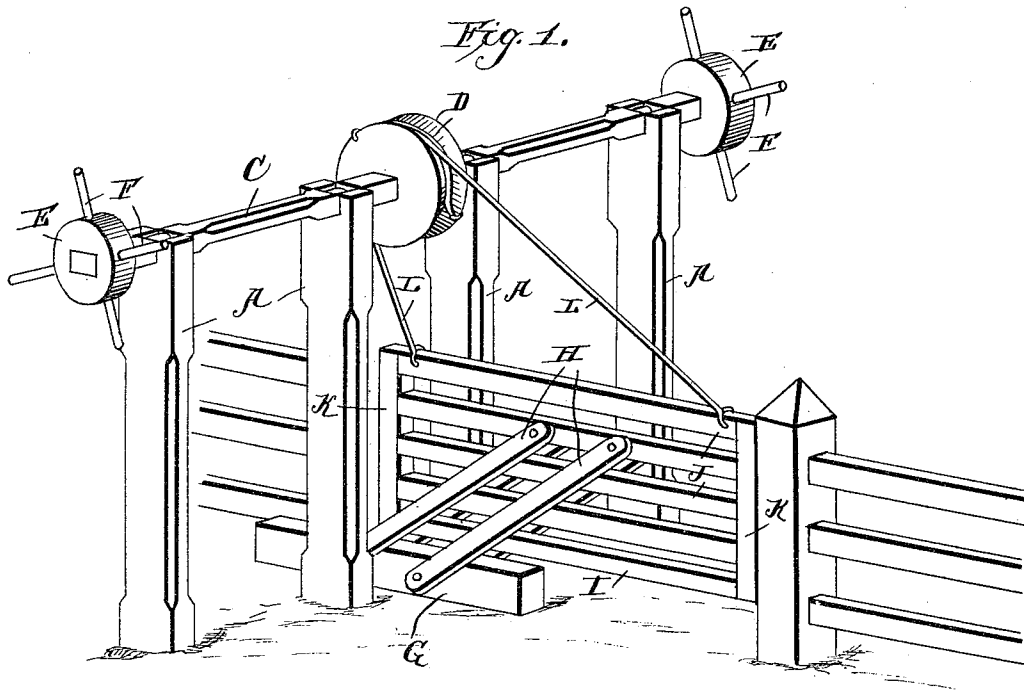

Witnesses.

Henry J. Diterich

R. W. Bishop.

Inventor,
Charles Tibbs

By *his* Attorneys

C. Snow

UNITED STATES PATENT OFFICE.

CHARLES TIBBS, OF VANDALIA, ILLINOIS.

GATE.

SPECIFICATION forming part of Letters Patent No. 403,401, dated May 14, 1889.

Application filed March 5, 1889. Serial No. 301,921. (No model.)

To all whom it may concern:

Be it known that I, CHARLES TIBBS, a citizen of the United States, residing at Vandalia, in the county of Fayette and State of Illinois, have invented new and useful Improvements in Gates, of which the following is a specification.

My invention relates to improvements in gates; and it consists in certain novel features hereinafter described and claimed.

In the accompanying drawings, Figure 1 is a perspective view showing my improved gate closed. Fig. 2 is a side view of the gate, showing the manner of operating the same.

In carrying out my invention I erect along one side of the road a series of posts, A A, which extend in opposite directions from the gateway, and have a rotary shaft, C, journaled in their upper ends. This rotary shaft C is provided at its center with a grooved pulley, D, and at its ends with suitable operating-handles, E. In the drawings I have shown these handles as consisting of disks having radiating arms F; but it will be understood, of course, that any other suitable form of handle could be employed.

At one side of the gateway, and between the center posts, A A, I arrange the fulcrum block or sill G, and to this fulcrum block or sill I pivot the lower ends of the swinging levers or gate-supports H H. The gate I is pivotally secured to the upper ends of the swinging levers H, and consists of the horizontal rails J and the vertical end bars, K, of the usual construction. At the opposite upper corners of the gate I secure the ends of the cables L L, which extend from the corners of the gate up to and over the grooved pulley D, passing each other on the said pulley and having their ends secured to it at diametrically-opposite points.

The operation of my improved gate is very simple, and, it is thought, will be readily understood. When it is desired to open the gate, the shaft is operated by turning the handle at either end, thereby rotating the grooved pulley, so as to draw on the cable secured to the front end of the gate and cause the said cable to lift the gate at its front end. Inasmuch,

however, as the gate is pivoted to the swinging levers, the lifting of the end of the gate will cause sufficient force to be exerted against the upper end of the swinging levers to raise the said levers and cause them to swing toward the posts, and thus move the entire body of the gate. The shaft is rotated sufficiently to bring the upper ends of the swinging levers slightly past the vertical plane of the said shaft, when the weight of the gate will carry the levers beyond the said plane and complete the opening of the gate. To close the gate the rotary shaft is turned in the reverse direction, as will be readily understood.

From the foregoing description it is evident that I have produced a gate which is composed of the fewest possible parts, and is therefore not liable to get out of order, and which can be operated very easily and rapidly by a person on horseback or in a vehicle without the necessity of alighting and while at a distance from the gate.

Having thus described my invention, what I claim, and desire to secure by Letters Patent, is—

1. The combination of the swinging levers, the gate supported thereby, the pulley arranged above the gate, means for operating said pulley, and the cables having their ends secured to the pulley at diametrically-opposite points, extending over the pulley in opposite directions, and secured to the opposite upper corners of the gate, as set forth.

2. The combination of the transverse sill, the swinging levers pivoted at their lower ends to the said sill, the gate pivoted to the upper ends of the said levers, the rotary shaft, the grooved pulley secured on said shaft, and the cables secured to the opposite upper corners of the gate and extending to and over the pulley and secured thereto, as set forth.

In testimony that I claim the foregoing as my own I have hereto affixed my signature in presence of two witnesses.

CHARLES TIBBS.

Witnesses:

AUGUST C. WALTER,
G. D. DURAND.