



- (51) **International Patent Classification:**
E04G 11/38 (2006.01) *E04G 19/00* (2006.01)
E04G 17/18 (2006.01) *E04B 5/16* (2006.01)
- (21) **International Application Number:**
PCT/AU2012/000715
- (22) **International Filing Date:**
21 June 2012 (21.06.2012)
- (25) **Filing Language:** English
- (26) **Publication Language:** English
- (30) **Priority Data:**
2011902438 22 June 2011 (22.06.2011) AU
- (71) **Applicant (for all designated States except US):** **FORM 700 PTY LTD** [AU/AU]; 270 Blackshaws Road, Altona North, VIC 3025 (AU).
- (72) **Inventor; and**
- (75) **Inventor/Applicant (for US only):** **ROSATI, Emilio** [AU/AU]; 20 Devonshire Road, Rossmore, NSW 2171 (AU).
- (74) **Agent:** **MADDERNS**; GPO Box 2752, Adelaide, S.A. 5001 (AU).

- (81) **Designated States (unless otherwise indicated, for every kind of national protection available):** AE, AG, AL, AM, AO, AT, AU, AZ, BA, BB, BG, BH, BR, BW, BY, BZ, CA, CH, CL, CN, CO, CR, CU, CZ, DE, DK, DM, DO, DZ, EC, EE, EG, ES, FI, GB, GD, GE, GH, GM, GT, HN, HR, HU, ID, IL, IN, IS, JP, KE, KG, KM, KN, KP, KR, KZ, LA, LC, LK, LR, LS, LT, LU, LY, MA, MD, ME, MG, MK, MN, MW, MX, MY, MZ, NA, NG, NI, NO, NZ, OM, PE, PG, PH, PL, PT, QA, RO, RS, RU, RW, SC, SD, SE, SG, SK, SL, SM, ST, SV, SY, TH, TJ, TM, TN, TR, TT, TZ, UA, UG, US, UZ, VC, VN, ZA, ZM, ZW.
- (84) **Designated States (unless otherwise indicated, for every kind of regional protection available):** ARIPO (BW, GH, GM, KE, LR, LS, MW, MZ, NA, RW, SD, SL, SZ, TZ, UG, ZM, ZW), Eurasian (AM, AZ, BY, KG, KZ, RU, TJ, TM), European (AL, AT, BE, BG, CH, CY, CZ, DE, DK, EE, ES, FI, FR, GB, GR, HR, HU, IE, IS, IT, LT, LU, LV, MC, MK, MT, NL, NO, PL, PT, RO, RS, SE, SI, SK, SM, TR), OAPI (BF, BJ, CF, CG, CI, CM, GA, GN, GQ, GW, ML, MR, NE, SN, TD, TG).

Published: — with international search report (Art. 21(3))

(54) **Title:** FORMWORK SUPPORT IMPROVEMENTS

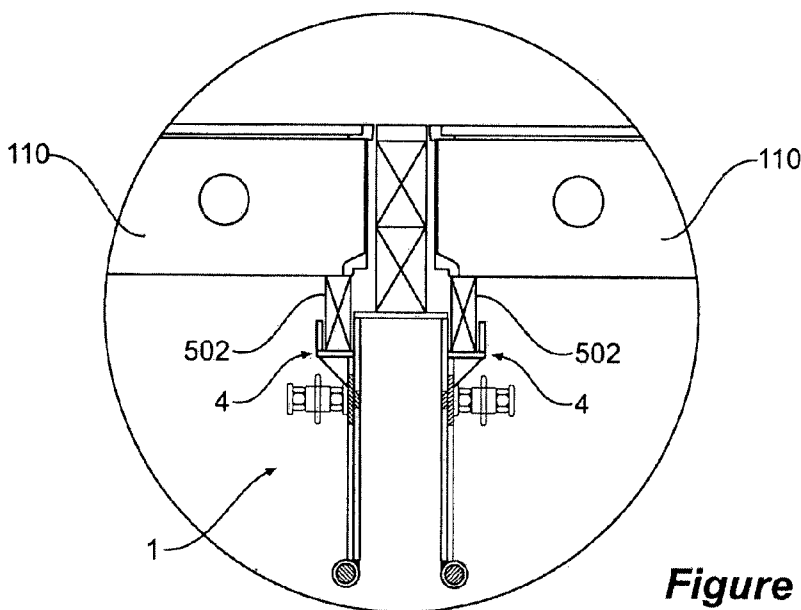

Figure 19

(57) **Abstract:** This invention relates to a bracket assembly for a hardware assembly for forming an elevated concrete slab or the like, the bracket assembly comprising a body securable to a supporting structure and a load bearing support carriage which depends from the body and is movable between at least upper and lower positions relative to the body whilst depending therefrom. An associated hardware assembly and method of use thereof are also disclosed.

WO 2012/174597 A1

TITLE

"FORMWORK SUPPORT IMPROVEMENTS"

FIELD OF THE INVENTION

5 This invention relates to a means for supporting concrete formwork.

PRIORITY

This patent application claims priority from:

10 Australian Provisional Patent Application No 2011902438, titled "FORMWORK SUPPORT IMPROVEMENTS", and filed on 22 June 2011.

The entire content of this application is hereby incorporated by reference.

15 BACKGROUND OF THE INVENTION

This invention relates to means and a method for forming elevated concrete slabs, and more particularly, to hardware used in the formation of these slabs, although it is not so limited in application.

20 In known building practice, formwork is assembled on a surface or on a lower floor level to form the next level of the building above. The formwork includes box forms to create columns, and table forms to form concrete beams and/or floor surfaces extending between the beams.

Table forms are normally held in position by scaffolding. The scaffolding is assembled on to the
25 surface or floor below with the table forms being supported on the scaffolding. The table forms are lowered in to position on to the scaffolding by cranes.

The table forms normally have plywood surfaces against which the concrete is poured. A series of joists are spaced along the underneath surface of the plywood and further bearers are located under the
30 joists which locate on the scaffolding to support the formwork.

The scaffolding is strong enough to support concrete which is then poured on to the formwork to create the next floor above. Once this concrete is set, and becomes self-supporting, then the scaffolding and formwork can be removed from beneath.

35

Normally, scissor lift mechanisms or platforms are used to support the table forms while the scaffolding is removed. The table form formwork is then prised away from the concrete surface and

lowered to ground level. All the components are stacked for the removal from the building site by forklift and crane.

The objects and advantages of the present invention will become apparent from the following
5 description, taken in connection with the accompanying drawings, wherein, by way of illustration and example, an embodiment of the present invention is disclosed.

SUMMARY OF THE INVENTION

In one aspect, the invention may be said to reside in a bracket assembly comprising a body securable
10 to a supporting structure and a load bearing support carriage which depends from the body and is movable between at least upper and lower positions relative to the body whilst depending therefrom.

In the context of this specification the carriage is a movable part of the bracket that bears the
formwork.

15

In one form, the formwork comprises a formwork panel. In an alternative, the formwork comprises sheets of material, such as aluminium or plywood sheets for instance.

20

It will be apparent to a person skilled in the relevant art that the bracket may be employed to support other objects. For instance, it may be employed to support a platform or mezzanine floor or further structural elements (such as beams) supporting the same.

25

In a further aspect then, the invention may be said to reside in a bracket assembly comprising a body adapted for securement to a supporting structure and a support providing carriage which is movable to
provide support at or between at least upper and lower positions relative to the body.

In one form, the body of the bracket assembly is adapted for releasable securement to the formwork supporting structure.

30

In one form, the formwork supporting structure is a portion of a formwork supporting frame.

In one form, the formwork supporting structure is a beam of the formwork supporting frame.

35

In one form, the body is shaped like a u-shaped saddle which is sized and adapted to seat over the formwork beam.

In one form, the carriage is slidably attached relative to the body of the bracket so as to be slidable between the first and second positions.

5 In one form, the carriage is pivotably attached relative to the body so as to be pivotable between the first and second positions.

In one form, the bracket comprises means for releasably securing the carriage in the first position.

10 In one form, the body comprises a pair of spaced apart side portions connected by a bridging portion.

In one form, the or each carriage is movable relative to one of these side portions.

In one form, the bracket assembly comprises a pair of carriages.

15 In a further aspect, the invention may be said to reside in an element of formwork supporting structure comprising a carriage which is movable between at least first and second positions relative to the element, wherein in the first position the carriage is adapted to support a formwork panel in place for concrete casting, and in the second position the carriage is spaced apart (i.e. separated) from the first position.

20 In a further aspect, the invention may be said to reside in a hardware assembly for forming an elevated concrete slab, the hardware assembly comprising a plurality of the above described brackets, where these brackets support formwork for forming an elevated concrete slab, the hardware assembly being adapted to provide support for the slab which is further to that provided via the brackets and
25 formwork.

In a further aspect, the invention may be said to reside in a method for forming an elevated concrete slab using the hardware assembly described above, the method comprising the steps of pouring the slab and allowing this to cure at least somewhat before shifting the carriages of the brackets to their
30 lower positions so that the formwork can be removed without disturbing other slab supporting hardware, which can remain in place to support the slab until such time as this is sufficiently cured as to be self-supporting.

35 A detailed description of one or more embodiments of the invention is provided below along with accompanying figures that illustrate by way of example the principles of the invention. While the invention is described in connection with such embodiments, it should be understood that the invention is not limited to any embodiment. On the contrary, the scope of the invention is limited only

by the appended claims and the invention encompasses numerous alternatives, modifications and equivalents. For the purpose of example, numerous specific details are set forth in the following description in order to provide a thorough understanding of the present invention.

- 5 The present invention may be practiced according to the claims without some or all of these specific details. For the purpose of clarity, technical material that is known in the technical fields related to the invention has not been described in detail so that the present invention is not unnecessarily obscured.

BRIEF DESCRIPTION OF THE DRAWINGS

- 10 For a better understanding of this disclosure it will now be described with respect to one or more exemplary embodiments, which shall be described herein with the assistance of drawings wherein:

Figure 1 is a side view of a hardware assembly for forming an elevated concrete slab;

- 15 Figure 2 is an end view of the hardware assembly of Figure 1;

Figure 3 is a plan view of the hardware assembly of Figure 1;

- 20 Figure 4 is an end view of a bracket assembly (from the hardware assembly) according to a first embodiment;

Figure 5 is a side view of the bracket assembly of Figure 4;

Figure 6 is a top view of the bracket assembly of Figure 4;

25

Figure 7 is an end view of the bracket assembly of Figure 4, where one of the carriages is shown in its second (i.e. not in use) position;

- 30 Figure 8 is a side view of the bracket assembly of Figure 4, where one of the carriages is shown in its second (i.e. not in use) position;

Figure 9 is an end view of a bracket assembly according to a second embodiment;

Figure 10 is a side view of the bracket assembly of Figure 9;

35

Figure 11 is a top view of the bracket assembly of Figure 9;

Figure 12 is an end view of the bracket assembly of Figure 9, where one of the carriages is shown in its second (i.e. not in use) position;

Figure 13 is a side view of the bracket assembly of Figure 9, where one of the carriages is shown in its second (i.e. not in use) position;

Figure 14 is a side view of a hardware assembly for forming an elevated concrete slab according to a further embodiment;

Figure 15 is an end view of the hardware assembly of Figure 14;

Figure 16 is a plan view of the hardware assembly of Figure 14;

Figure 17 is a detail side view of the hardware assembly of Figure 14;

Figure 18 is a detail end view of the hardware assembly of Figure 15;

Figure 19 is a detail view taken at detail 1 of Figure 17;

Figure 20 is a side view of a hardware assembly for forming an elevated concrete slab according to a further embodiment;

Figure 21 is an end view of the hardware assembly of Figure 20;

Figure 22 is a plan view of the hardware of Figure 20;

Figure 23 is a detail side view of the hardware assembly of Figure 20; and

Figure 24 is a detail end view of the hardware assembly of Figure 21.

In the following description, like reference characters designate like or corresponding parts throughout the several views of the drawings.

DESCRIPTION OF A PREFERRED EMBODIMENT

Referring now to Figures 1 through 3, where there is illustrated a hardware assembly 100 for forming an elevated concrete slab, the hardware assembly 100 comprising support frames 102 supporting an

array of timber bearers 104, which in turn support an array of timber joists 106 sitting atop of and extending normal to the bearers 104.

5 The timber joists 106 support an array of brackets 1, and these brackets 1 are adapted to support formwork panels 110, such as for instance, panels of the type sold under the proprietary name 'AIRODECK', or sheets of material, such as aluminium or plywood for instance.

10 Referring now to Figures 4 through 8, each bracket assembly 1 comprises a body 2 adapted for releasable securement to a joist 106 and a carriage 4 which is movable between at least first and second positions relative to the body 2. In the first position (see Figure 4) the carriage 4 is adapted to support a formwork panel 110 in place for forming the elevated concrete slab, and in the second position (see Figure 7) the carriage 4 is spaced apart (i.e. separated) from the first position.

15 The carriage 4 then is a movable part of the bracket assembly 1 that bears the formwork panel 110.

The body 2 of the bracket assembly 1 is shaped like a u-shaped saddle that is sized and adapted to seat over the joist 106. This u-shaped saddle comprises a pair of spaced apart side portions 6 connected by an uppermost bridging portion 8. In use then, the bridging portion 8 of the u-shaped saddle seats over the joist 106 and the side portions 6 extend down opposing sides of the joist 106. A threaded stud 10 extends out from each of the side portions 6 of the bracket assembly 1.

Each of the side portions 6 terminates in a hinge 12 that pivotably connects the carriage 4 to the body 2 so that the carriage 4 can pivot between its first and second positions.

25 The carriage comprises a plate like wing 14 which terminates at its outermost end in an outwardly extending flange 16 which is reinforced by a gusset 18. It is on this outwardly extending flange 16 that an edge of the formwork panel 110 will rest when this is supported by the bracket assembly 1. There is an upwardly directed lip 20 extending from an outer edge of the flange 16 which assists to retain the formwork panel 110 on the flange 16. There is a gap 22 in the upwardly directed lip 20 which is sized so that the edges of two panels 110 can locate in this gap 22, and one bracket assembly 1 can support two formwork panels 110.

30 When in the first position, the carriage wing 14 extends upward and adjacent to the side portion 6 of the bracket body 2 so that the flange 16 is positioned at or about the level of the top of the joist 106. There is an aperture 24 through the wing 14 through which the threaded stud 24 can extend when the carriage wing 14 is in this first position. With the carriage wing 14 in this first position a nut 26 can be

screwed onto the threaded stud 10 to releasably secure the carriage wing 14 in place in the first position.

When released and moved to its second position, the carriage wing 14 hangs down from its hinge 12 and the unused nut 26 hangs from a tether 28 that terminates at the wing 14 so that the nut 26 cannot be inadvertently dropped from a height.

Referring once more to Figures 1 through 3, where it is illustrated how in use, one or more formwork panels 110 can be suspended between adjacent support frames 102 and a pair of adjacent joists 106 which are in turn supporting brackets 1 that are configured to support the formwork panels 110.

Because the formwork panels 110 have some depth to them, infill beams 108 are seated atop the joists 106 to fill the void that would otherwise exist between the top of the joists 106 and top of the formwork panels 110.

Plywood sheets, strips 112 and timbers can be used to fill any gaps in and around the formwork panels 110 prior to pouring of the concrete slab.

An advantage of these bracket assemblies 1, is that after the concrete slab has been formed the formwork panels 110 can be removed for use elsewhere, without leaving the slab unsupported.

For example, it may be possible to remove the formwork panels 110 three days after pouring the slab, but it may be necessary to leave the remaining slab supporting hardware in place for up to fourteen days after the slab was poured. In this case, the same formwork panels 110 could have been used to form an additional three slabs in the eleven days that pass before the remaining slab supporting hardware is removed. The saving in the number of formwork panels 110 required then is appreciable.

The formwork panels 110 are removed by removing the nut 26 from the threaded stud 10 of the bracket assembly and rotating the carriage wing 14 from its first or in-use position supporting the formwork panel 110, to its second, downward hanging position. The formwork panel 110 can then be lowered between adjacent supporting frames 102 and adjacent supporting joists 106.

Referring now to Figures 9 through 11, where a bracket assembly 200 according to an alternate embodiment is illustrated.

The carriage 204 of bracket assembly 200 is slidably attached relative to the body 202 of the bracket assembly 200 so as to be vertically slidable between the first and second positions.

As was the case with the bracket assembly 1 according to the first embodiment the body 2 of the bracket assembly 200 is shaped like a u-shaped saddle that is sized and adapted to seat over the joist 106. This u-shaped saddle comprises a pair of spaced apart side portions 6 connected by an uppermost bridging portion 8. In use then, the bridging portion 8 of the u-shaped saddle seats over the joist 106 and the side portions 6 extend down opposing sides of the joist 106.

The carriage 204 comprises a plate 206 which terminates at its uppermost end in an outwardly extending flange 16 which is reinforced by a gusset 18.

Each side portion 6 defines a slot-like track between inner 6b and outer portions 6a thereof in which the plate 206 of the carriage 204 is slidably retained.

The carriage 204 can be releasably secured in the first, in use, position by way of a pin 210 passed through aligned apertures 212 in each of the carriage plate, bracket side portions and the joist 106.

As was the case with the bracket 1 according to the first embodiment, after the concrete slab has been formed the formwork panels 110 can be removed for use elsewhere, without disturbing the remaining slab supporting hardware, which can remain in place to support the slab until such time as this is sufficiently cured as to be self-supporting.

The panels are removed by removing the pin 210 and sliding the carriage 204 down from its first or in-use position supporting the formwork panel 110, to its second, lower position. The formwork panel 110 can then be lowered between the adjacent supporting frames 102 and adjacent supporting joists 106.

Where formwork panels could be removed from previous hardware assemblies, the slab was left supported at points only, on the heads of props. An advantage of the system according to the present invention then is that the slab is left supported on continuous beams (joists 106) after the formwork panels are removed. It will be appreciated that a beam can spread the weight of the slab over its length, whereas supporting the slab at points on props creates points of high stress concentration in the slab.

The present invention provides an advantage then in as much the formwork panels 110 can be removed without disturbing the joists 106 that supported the formwork panels 110, meaning these joists 106 remain in position to support the slab whilst this finishes curing, while making the formwork panels 110 available for use elsewhere.

Referring now to Figures 14 through 19, where there is illustrated a hardware assembly 500 for forming an elevated concrete slab, which differs from hardware assembly 100 in as much as the carriages 4 of brackets 1 support intermediate beams 502, which in turn support the formwork panels 110.

5

Referring now to Figures 20 through 24, where there is illustrated a hardware assembly 600 for forming an elevated concrete slab, which differs from hardware assembly 500 in as much as the carriages 204 of brackets 200 support intermediate beams 602, which in turn support the formwork panels 110.

10

Hardware assemblies 500 and 600 offer all of the advantages of hardware assembly 100 discussed above, along with the added benefit that the positioning of the brackets 1 or 200 need not be dictated by the dimensions of the formwork, this being formwork panels 110 in this case, as previously, formwork panels 110 were supported at abutting edges. In this way, it may be possible to support the same number of formwork panels 110 using less brackets 1 or 200.

15

Throughout the specification and the claims that follow, unless the context requires otherwise, the words “comprise” and “include” and variations such as “comprising” and “including” will be understood to imply the inclusion of a stated integer or group of integers, but not the exclusion of any other integer or group of integers.

20

The reference to any prior art in this specification is not, and should not be taken as, an acknowledgement of any form of suggestion that such prior art forms part of the common general knowledge.

25

It will be appreciated by those skilled in the art that the invention is not restricted in its use to the particular application described. Neither is the present invention restricted in its preferred embodiment with regard to the particular elements and/or features described or depicted herein. It will be appreciated that various modifications can be made without departing from the principles of the invention. Therefore, the invention should be understood to include all such modifications in its scope.

30

CLAIMS:

1. A bracket assembly for a hardware assembly for forming an elevated concrete slab or the like, the bracket assembly comprising a body securable to a supporting structure and a load bearing support carriage which depends from the body and is movable between at least upper and lower positions relative to the body whilst depending therefrom.
5
2. The bracket assembly of claim 1, wherein the support carriage has a range of movement extending between its upper and lower positions, and the support carriage acts to provide support for at least a portion of the load throughout this range of movement.
10
3. The bracket assembly of claim 1, wherein the support carriage acts to provide support for the load in its upper position only.
4. The bracket assembly as in either of claims 2 or 3, wherein the carriage is slidably attached relative to the body of the bracket so as to be slidable between the upper and lower positions.
15
5. The bracket assembly as in either of claims 2 or 3, wherein the carriage is pivotably attached relative to the body so as to be pivotable between the upper and lower positions.
20
6. The bracket assembly as in any one of the preceding claims, wherein the bracket comprises means for releasably securing the support carriage in at least the upper position.
7. The bracket assembly as in any one of the preceding claims, wherein the body of the bracket assembly is adapted for releasable securement to the supporting structure.
25
8. The bracket assembly as in any one of the preceding claims, wherein the body comprises a pair of spaced apart side portions connected by a bridging portion.
9. The bracket assembly of claim 8, wherein from each side portions there depends a load bearing support carriage.
30
10. The bracket assembly as in any one of the preceding claims, wherein body is shaped like a u-shaped saddle which is sized and adapted to seat over the supporting structure.
35
11. The bracket assembly as in any one of the preceding claims, wherein the formwork supporting structure comprises a portion of a frame or stand.

12. The bracket assembly as in any one of the preceding claims, wherein the formwork supporting structure or portion thereof is a beam..
- 5 13. The bracket assembly as in any one of the preceding claims, wherein the load is a formwork for concrete casting.
14. The bracket assembly of claim 13, wherein the formwork comprises a formwork panel.
- 10 15. The bracket assembly of claim 13, wherein the formwork comprises sheets of material, such as aluminium or plywood sheets for instance.
16. The bracket assembly as in any one of claims 13 through 15, wherein in the upper position the carriage supports the formwork for forming an elevated concrete slab in place for concrete casting, and
15 in the lower position the carriage is spaced apart (i.e. separated) from the slab.
17. The bracket assembly of claim 16, wherein in the lower position, the carriage is so spaced apart from the slab that the formwork can be separated from the slab and the carriage.
- 20 18. The bracket assembly as in any one of claims 1 through 12, wherein the load is any one or more of a platform or mezzanine floor or further structural elements (such as beams) supporting the same.
19. A bracket assembly comprising a body adapted for securement to a formwork supporting
25 structure, and a carriage which is movable between at least first and second positions relative to the body, wherein in at least the first position the carriage is adapted to support formwork for forming an elevated concrete slab in place for concrete casting, and in the second position the carriage is spaced apart (i.e. separated) from the first position.
- 30 20. A hardware assembly for forming an elevated concrete slab, the hardware assembly comprising a plurality of the bracket assemblies of any one of claims 1 through 17, where these brackets assemblies support formwork for forming an elevated concrete slab, the hardware assembly being adapted to provide support for the slab which is further to that provided via the bracket assemblies and formwork.
- 35 21. A method for forming an elevated concrete slab using the hardware assembly of claim 18, the method comprising the steps of pouring the slab and allowing this to cure at least somewhat before

shifting the carriages of the bracket assemblies to their lower positions so that the formwork can be removed without disturbing other slab supporting hardware, which can remain in place to support the slab until such time as this is sufficiently cured as to be self-supporting.

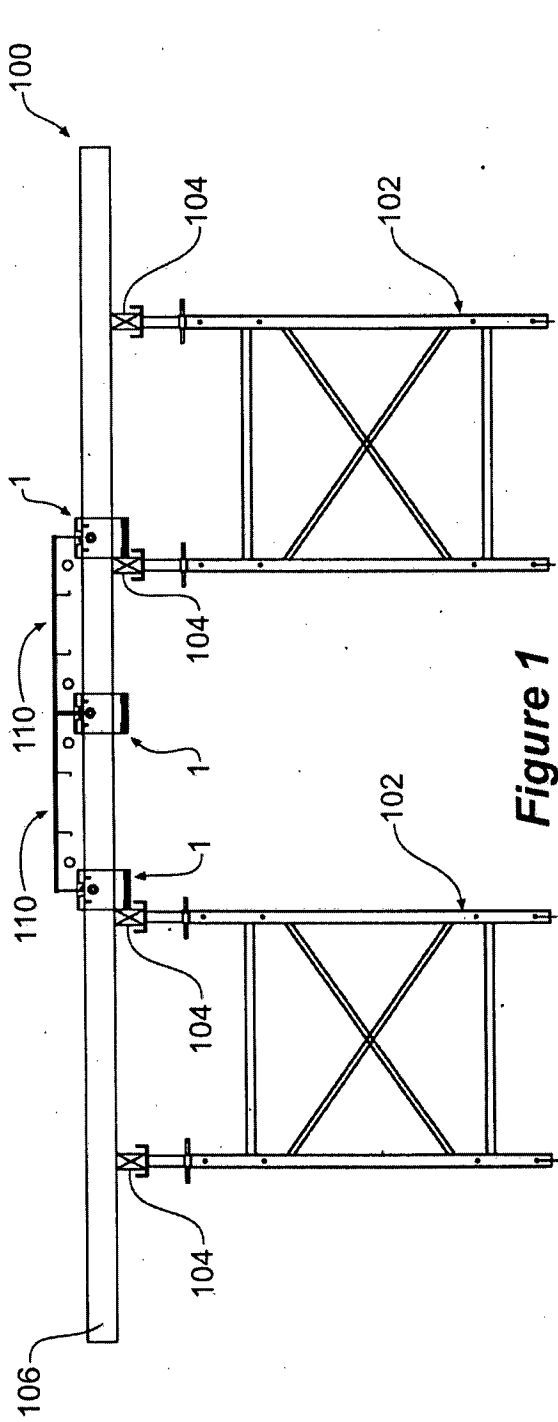

Figure 1

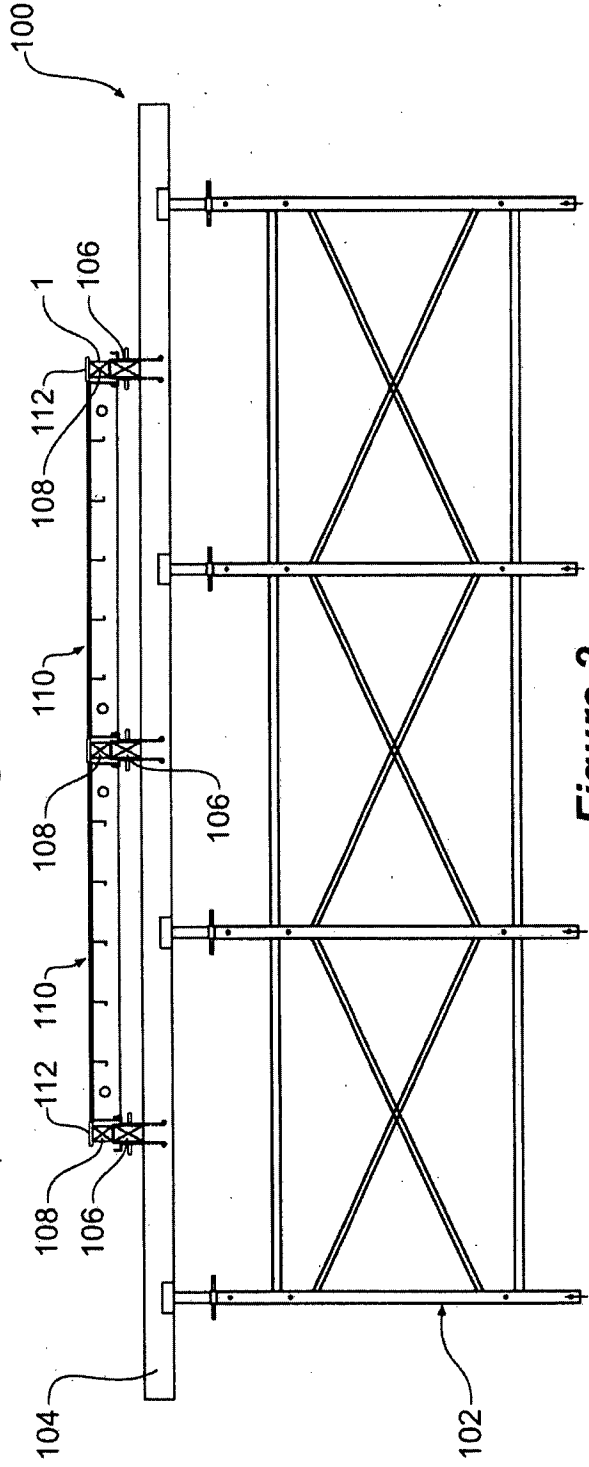

Figure 2

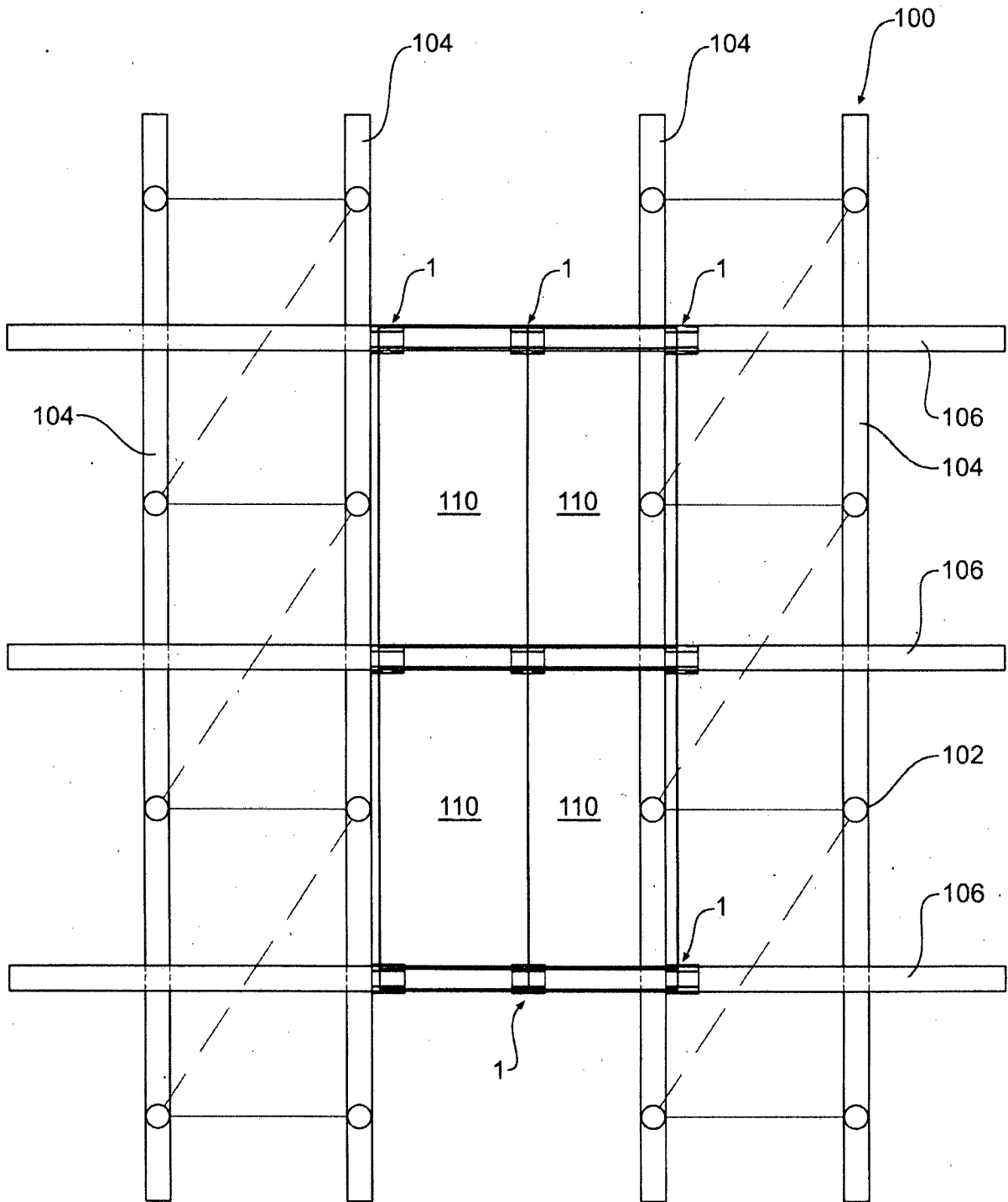

Figure 3

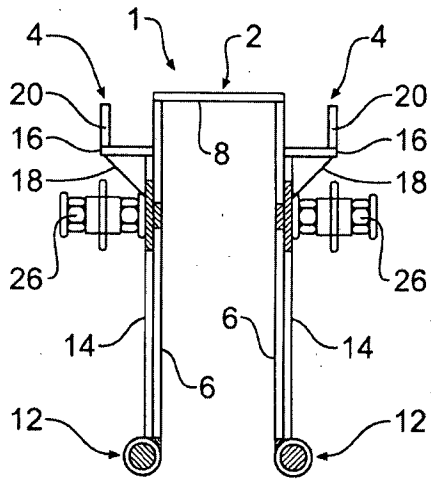

Figure 4

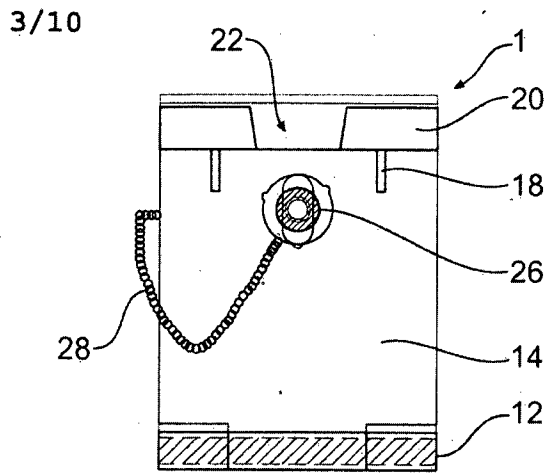

Figure 5

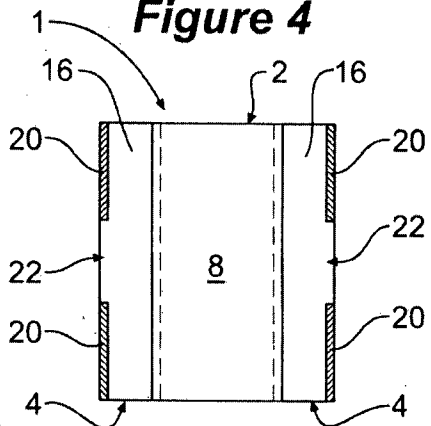

Figure 6

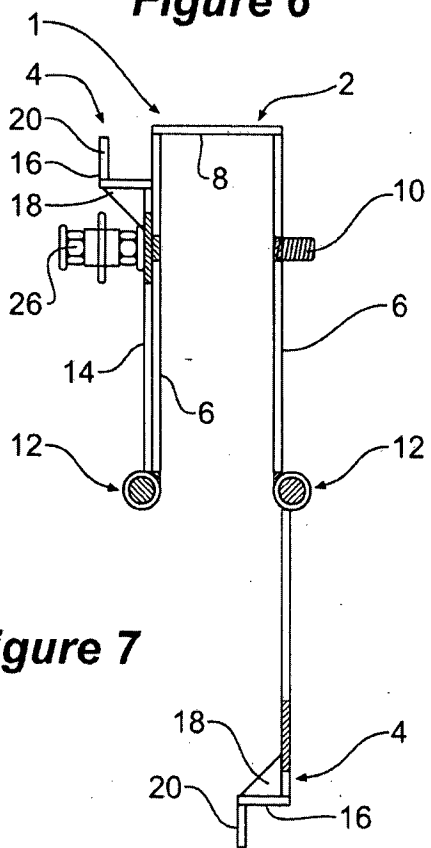

Figure 7

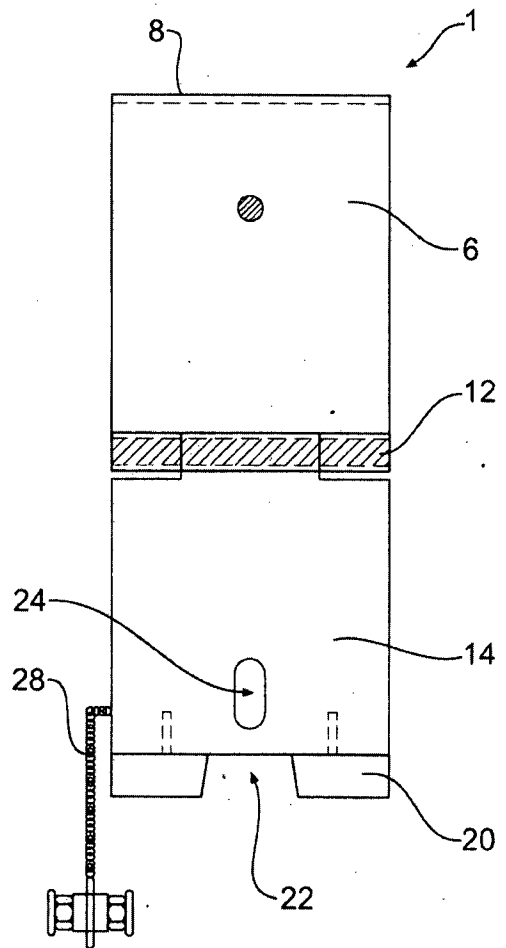

Figure 8

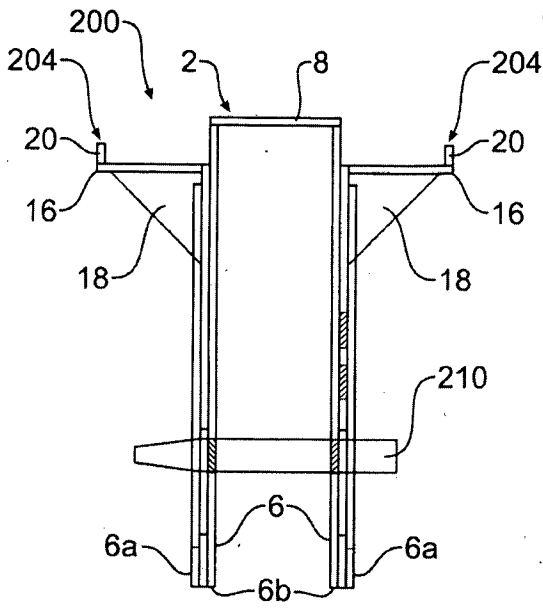

Figure 9

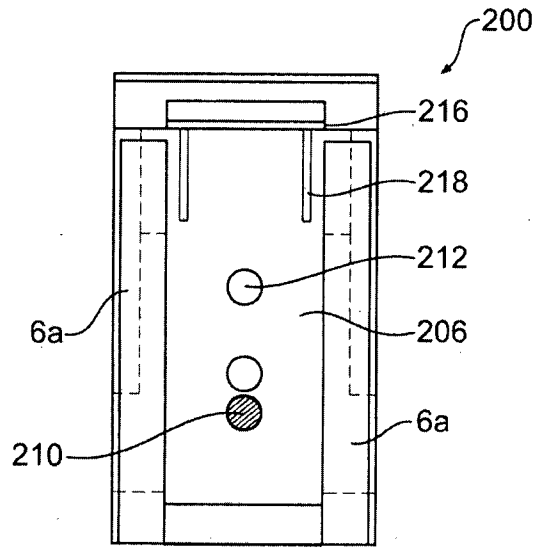

Figure 10

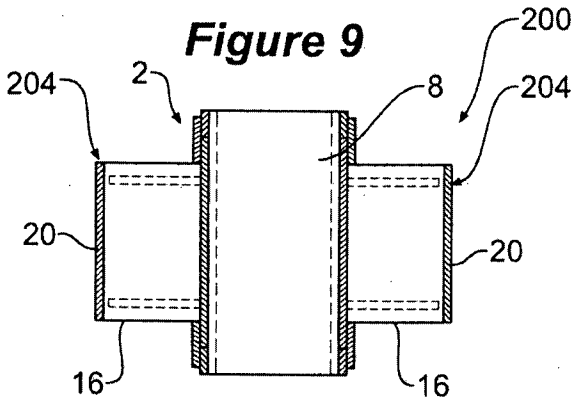

Figure 11

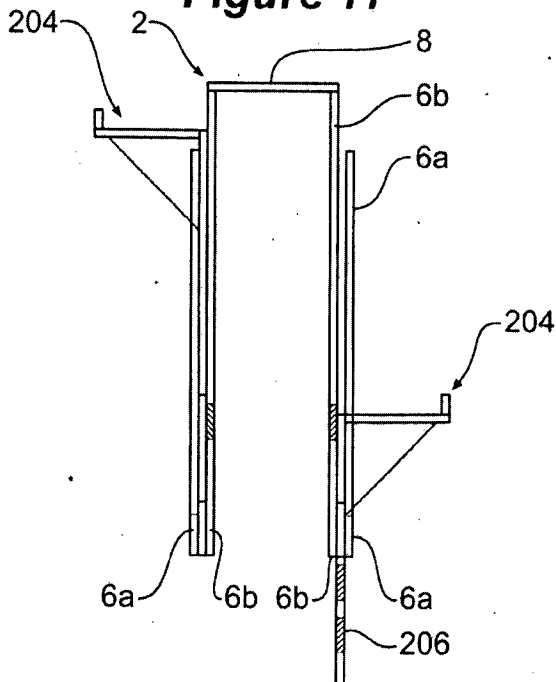

Figure 12

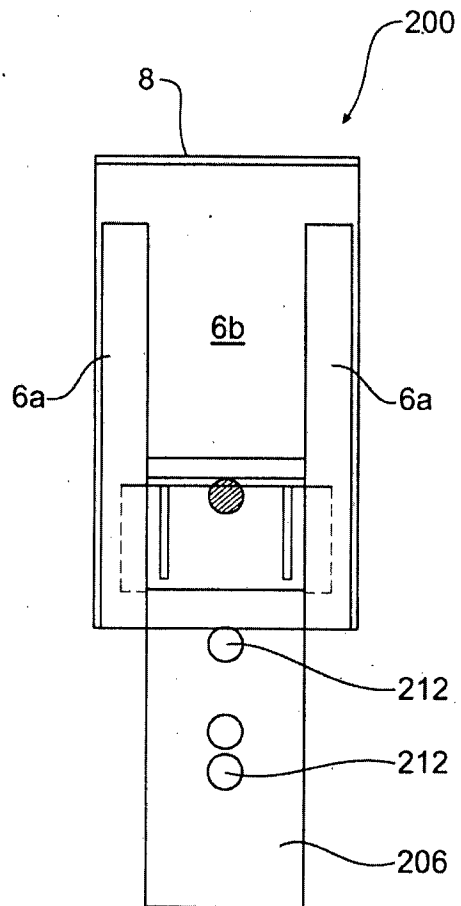

Figure 13

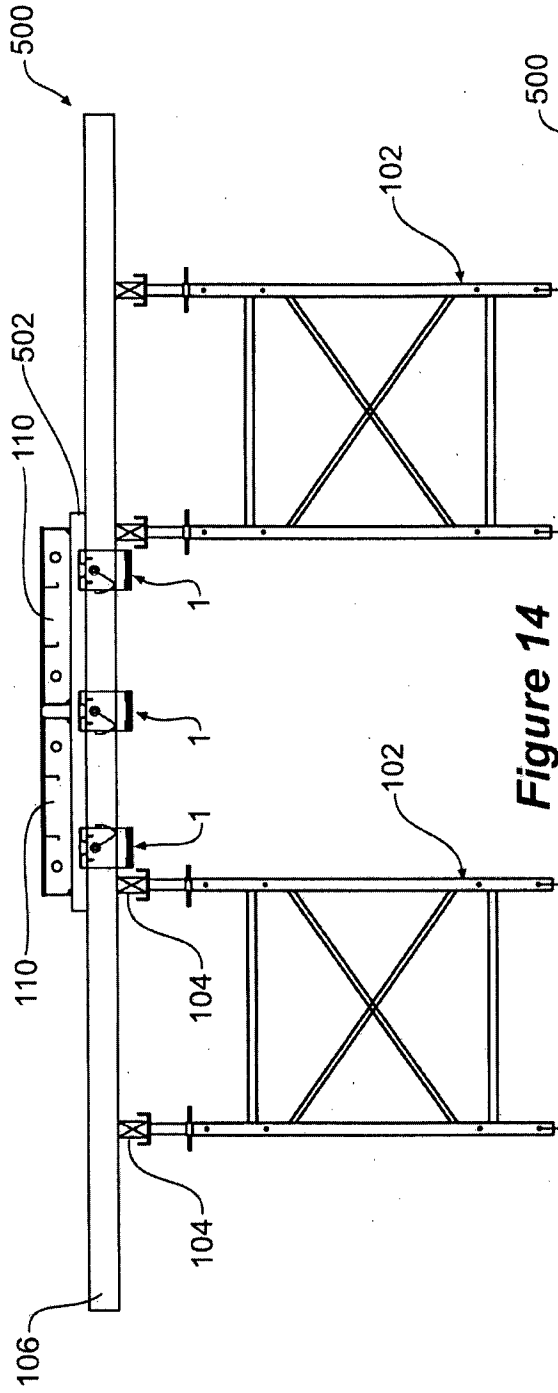

Figure 14

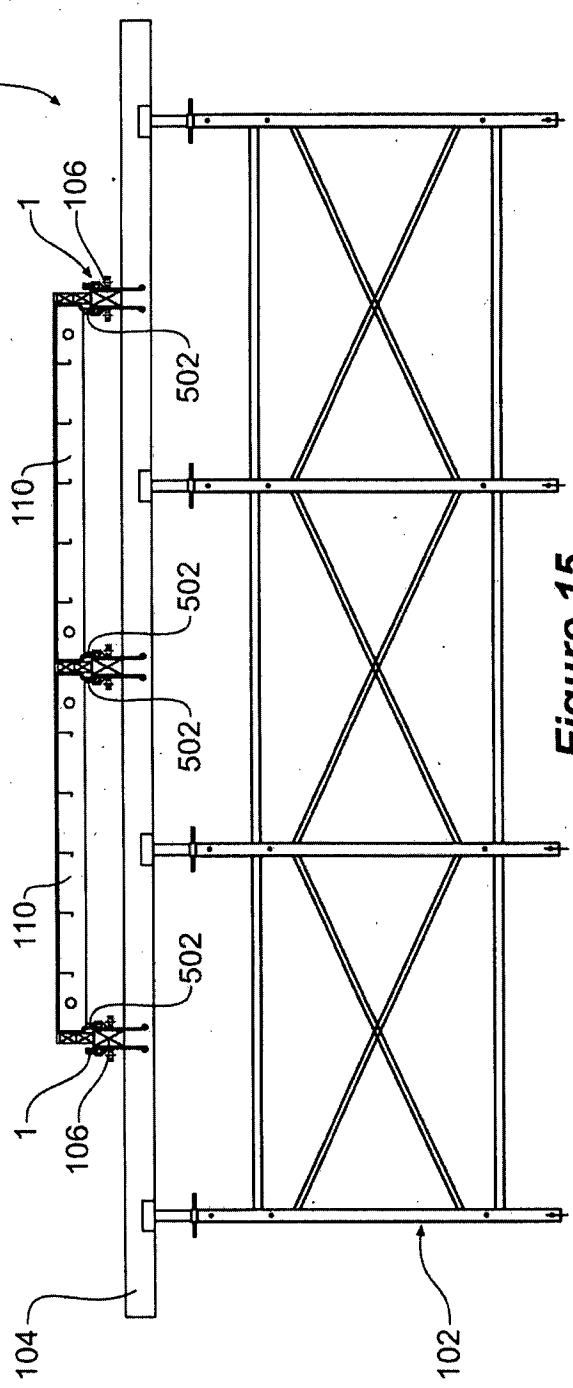

Figure 15

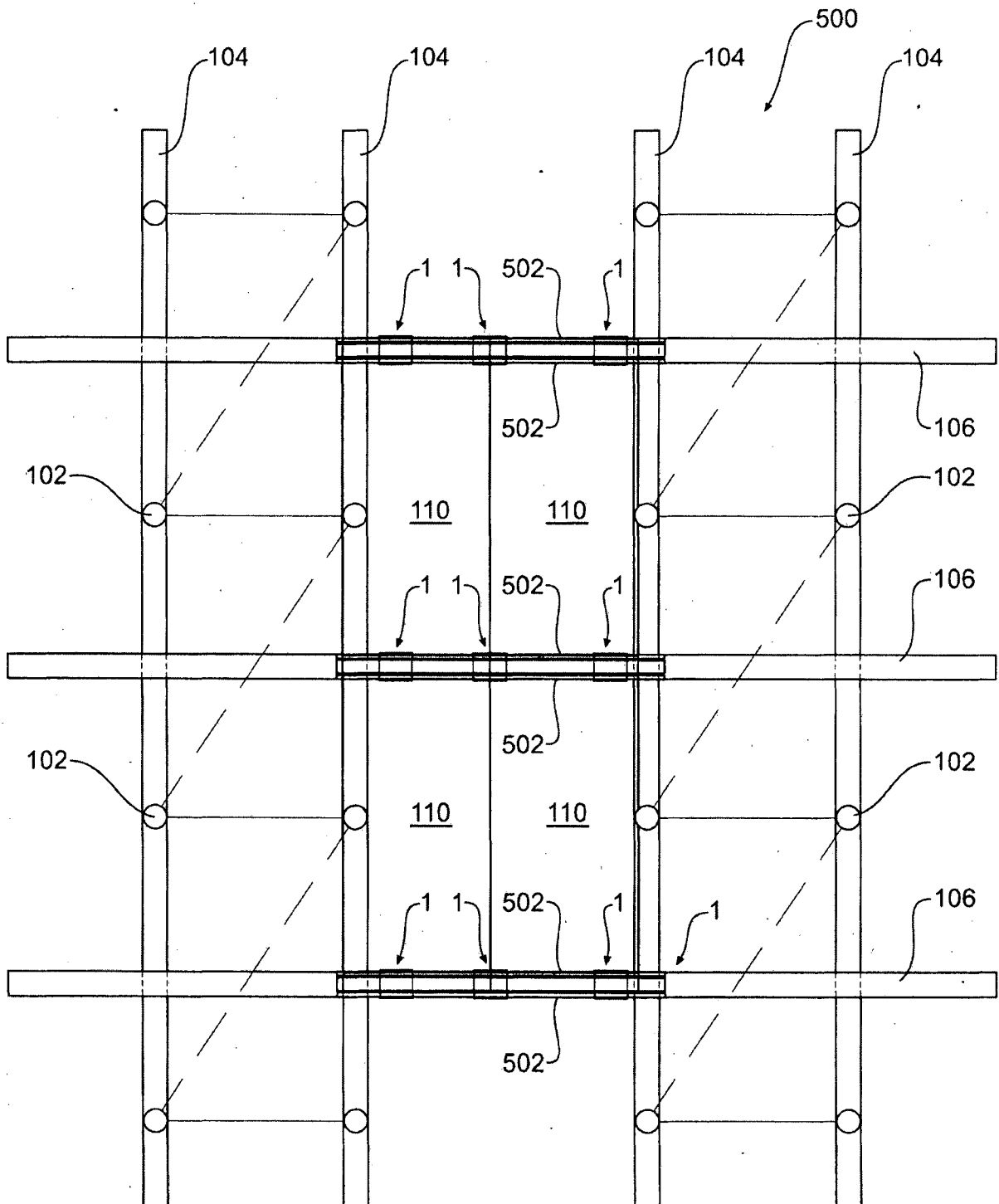

Figure 16

7/10

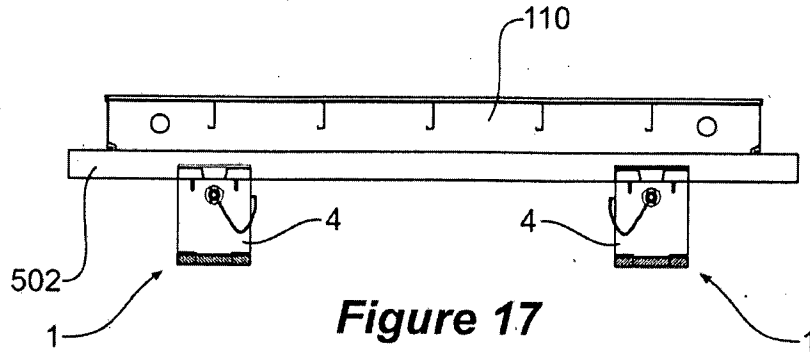

Figure 17

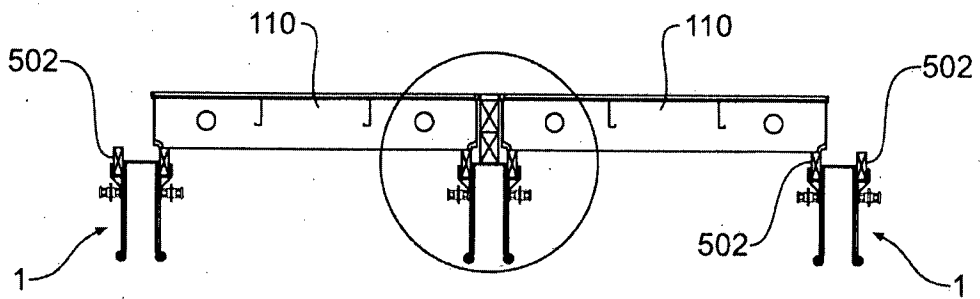

Figure 18

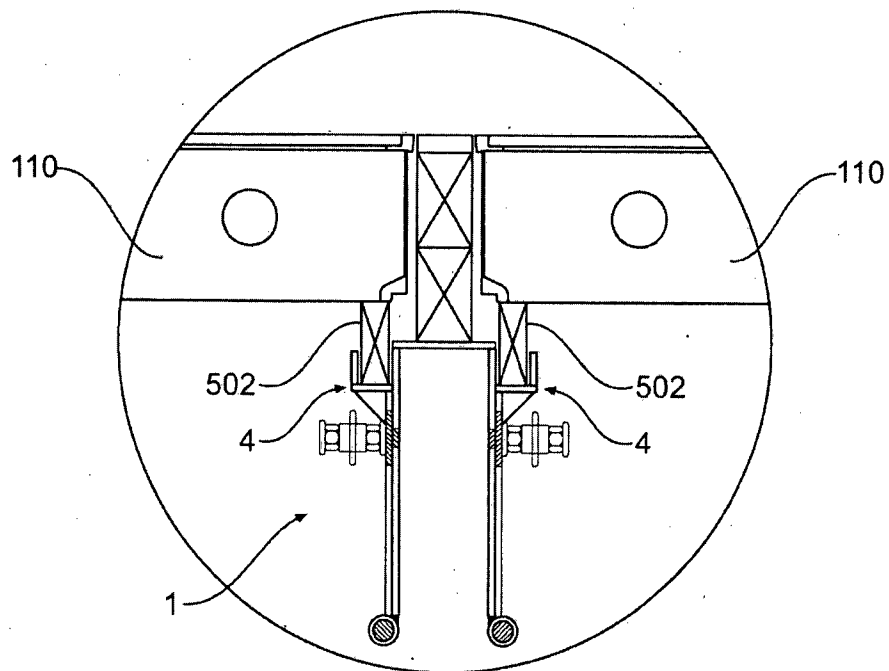

Figure 19

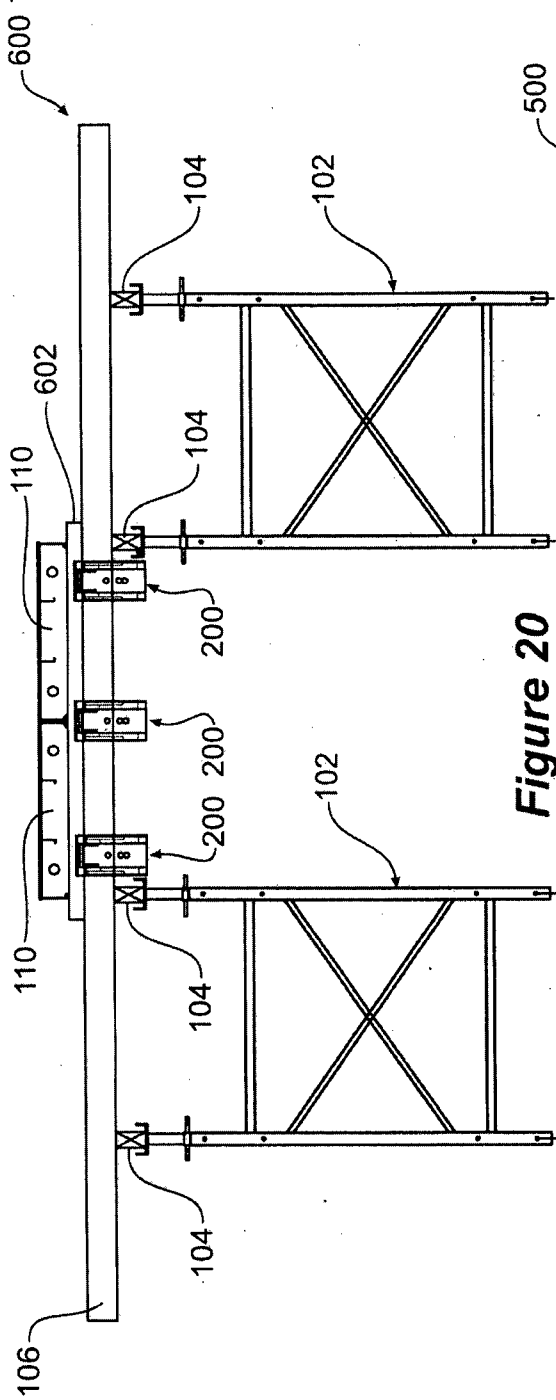

Figure 20

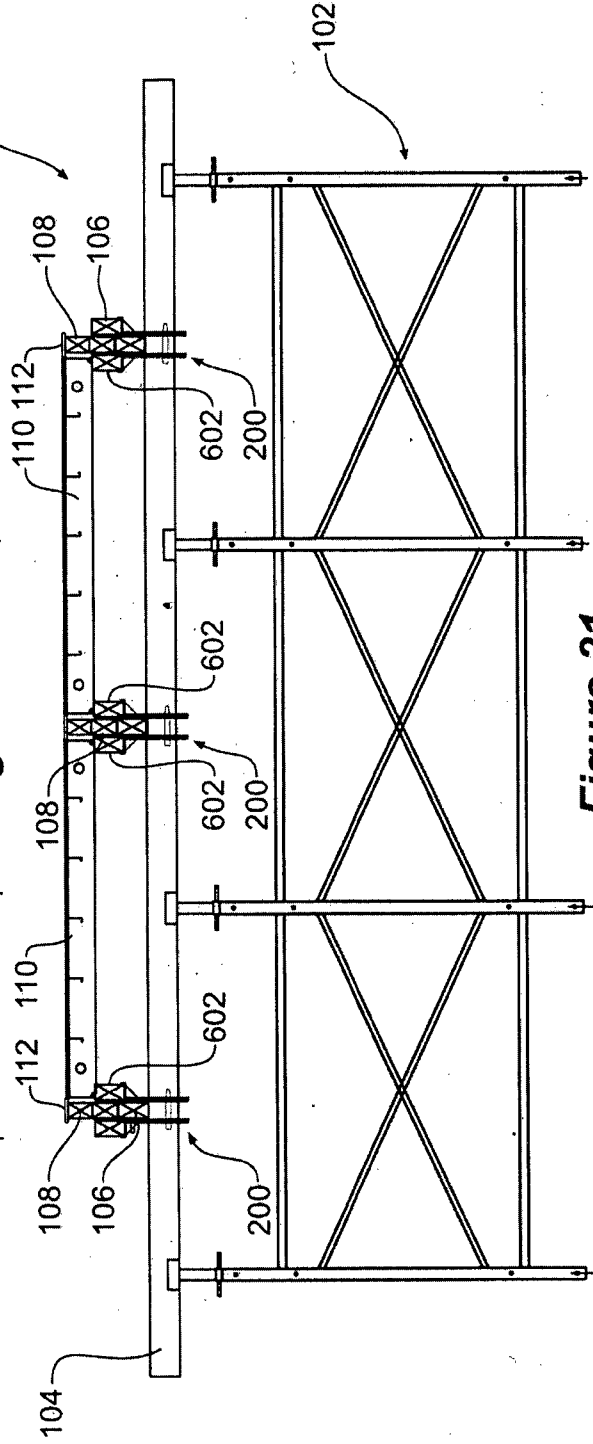

Figure 21

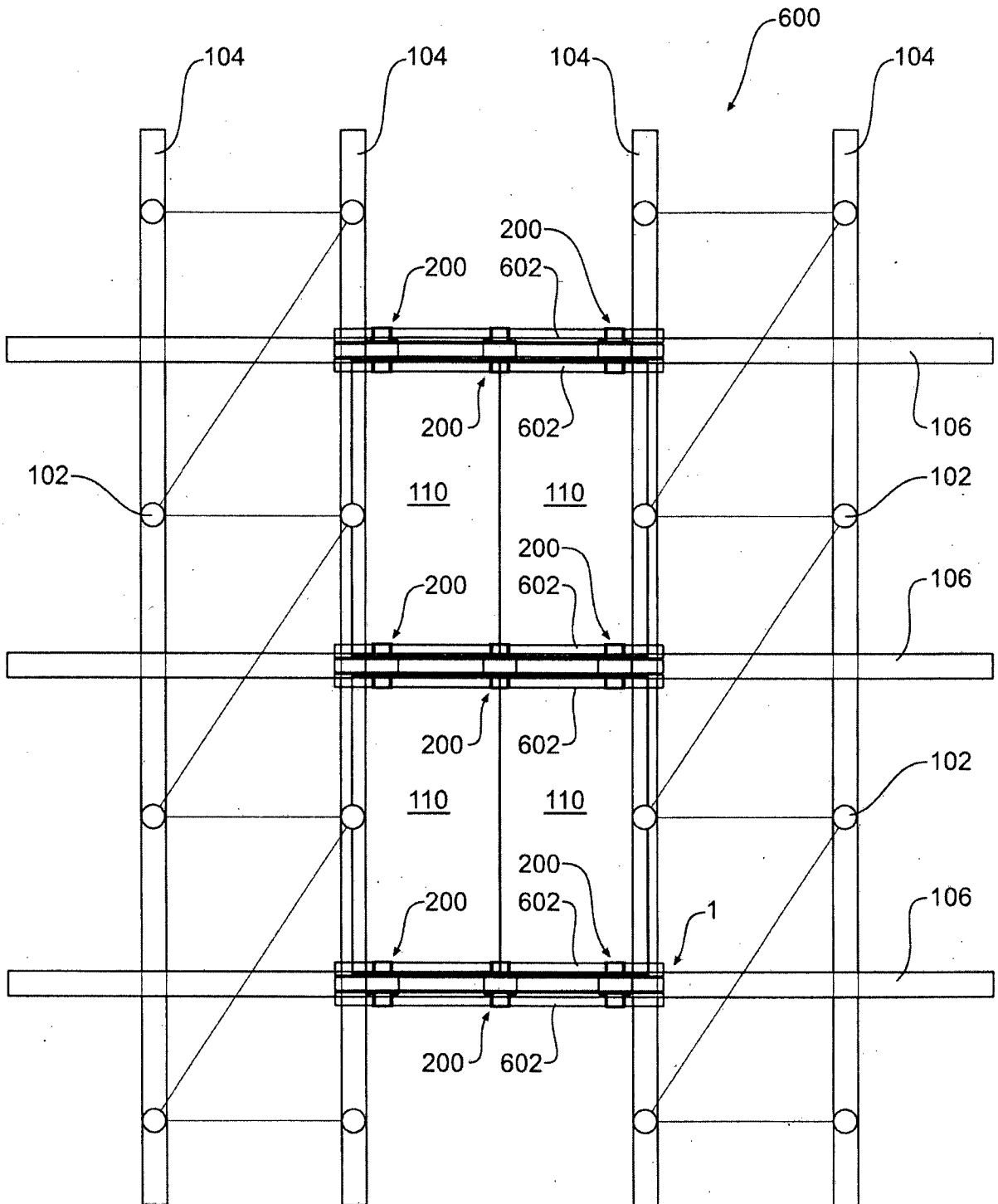

Figure 22

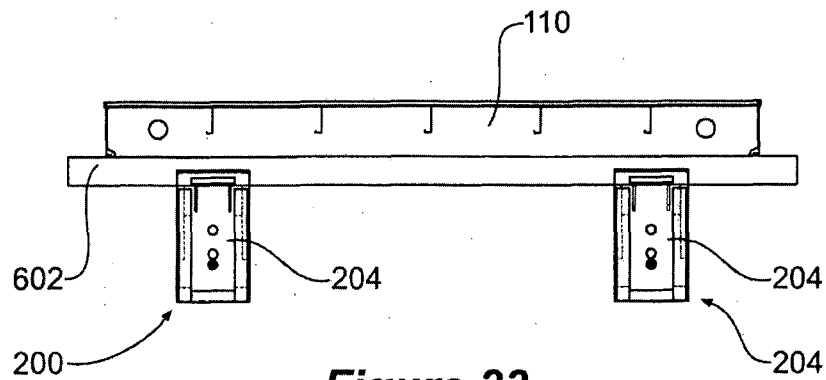

Figure 23

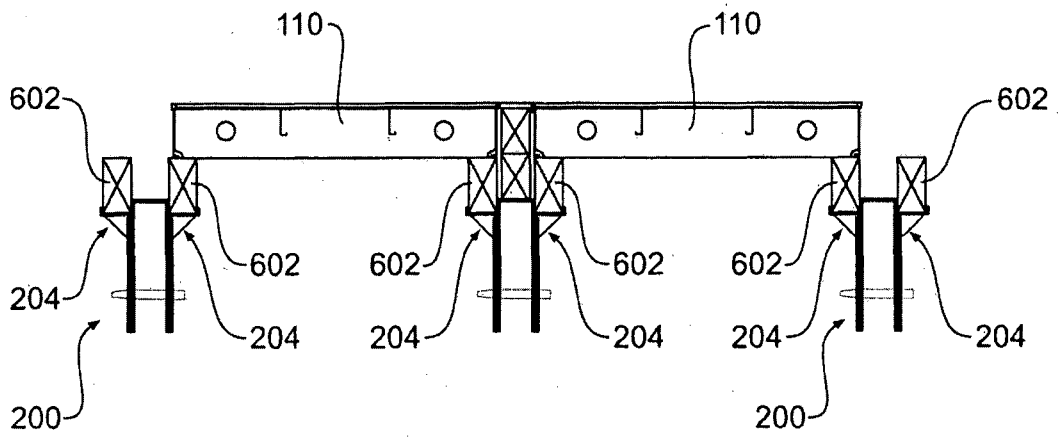

Figure 24

INTERNATIONAL SEARCH REPORT

International application No.

PCT/AU2012/000715

A. CLASSIFICATION OF SUBJECT MATTER

E04G 11/38 (2006.01) E04G 17/18 (2006.01) E04G 19/00 (2006.01) E04B 5/16 (2006.01)

According to International Patent Classification (IPC) or to both national classification and IPC

B. FIELDS SEARCHED

Minimum documentation searched (classification system followed by classification symbols)

Documentation searched other than minimum documentation to the extent that such documents are included in the fields searched

Electronic data base consulted during the international search (name of data base and, where practicable, search terms used)

EPODOC, WPI: /IC/EC E04G11/36/LOW, E04B5/16/LOW, E04G19/00, E04G17 & Keywords (Joist, Beam, Bearer, Formwork, Slab, Shuttering, Deck, Support, Mount, Bracket, Saddle, Dismantle, Collapse, Pivot, Hinge, Slide, Translate) and similar terms/combinations.

C. DOCUMENTS CONSIDERED TO BE RELEVANT

Category*	Citation of document, with indication, where appropriate, of the relevant passages	Relevant to claim No.
	Documents are listed in the continuation of Box C	



Further documents are listed in the continuation of Box C



See patent family annex

* Special categories of cited documents:		
"A" document defining the general state of the art which is not considered to be of particular relevance	"T" later document published after the international filing date or priority date and not in conflict with the application but cited to understand the principle or theory underlying the invention	
"E" earlier application or patent but published on or after the international filing date	"X" document of particular relevance; the claimed invention cannot be considered novel or cannot be considered to involve an inventive step when the document is taken alone	
"L" document which may throw doubts on priority claim(s) or which is cited to establish the publication date of another citation or other special reason (as specified)	"Y" document of particular relevance; the claimed invention cannot be considered to involve an inventive step when the document is combined with one or more other such documents, such combination being obvious to a person skilled in the art	
"O" document referring to an oral disclosure, use, exhibition or other means	"&" document member of the same patent family	
"P" document published prior to the international filing date but later than the priority date claimed		

Date of the actual completion of the international search
2 October 2012Date of mailing of the international search report
02 October 2012

Name and mailing address of the ISA/AU

AUSTRALIAN PATENT OFFICE
PO BOX 200, WODEN ACT 2606, AUSTRALIA
Email address: pct@ipaustralia.gov.au
Facsimile No.: +61 2 6283 7999

Authorised officer

Roger Small
AUSTRALIAN PATENT OFFICE
(ISO 9001 Quality Certified Service)
Telephone No. 0399359630

INTERNATIONAL SEARCH REPORT C (Continuation). DOCUMENTS CONSIDERED TO BE RELEVANT		International application No. PCT/AU2012/000715
Category*	Citation of document, with indication, where appropriate, of the relevant passages	Relevant to claim No.
X Y	DE 155308 C (STIEPER) 11 November 1904 See figs. 1 to 6. See figs. 1 to 6.	1, 3, 5-7, 12-19, 21 11
X Y	GB 582027 A (YEOMANS) 01 November 1946 See figs. 1 to 3 & page 1, lines 44-49. See figs. 1 to 3 & page 1, lines 44-49.	1-2, 4, 6-7, 13-19, 21 11-12
X	SU 670708 A1 (STEPANOVICH) 30 June 1979 English abstract retrieved from EPODOC database. See abstract & figs. 1 to 3.	1-2, 4, 6, 8-21
Y	US 3294357 A (TOOLEY) 27 December 1966 See figs. 1 to 4.	11-12
A	US 3954248 A (BARBER) 04 May 1976 See figs. 1 to 7.	

INTERNATIONAL SEARCH REPORT

Information on patent family members

International application No.

PCT/AU2012/000715

This Annex lists known patent family members relating to the patent documents cited in the above-mentioned international search report. The Australian Patent Office is in no way liable for these particulars which are merely given for the purpose of information.

Patent Document/s Cited in Search Report		Patent Family Member/s	
Publication Number	Publication Date	Publication Number	Publication Date
DE 155308 C	11 Nov 1904	None	
GB 582027 A	01 Nov 1946	GB 582027 A	01 Nov 1946
SU 670708 A1	30 Jun 1979	SU 670708 A1	30 Jun 1979
US 3294357 A	27 Dec 1966	CH 414127 A	31 May 1966
		GB 1106621 A	20 Mar 1968
		US 3294357 A	27 Dec 1966
US 3954248 A	04 May 1976	US 3954248 A	04 May 1976

End of Annex