

(No Model.)

4 Sheets—Sheet 1.

F. LESTER.
REVERSIBLE STEAM ENGINE.

No. 523,360.

Patented July 24, 1894.

Fig. 1.

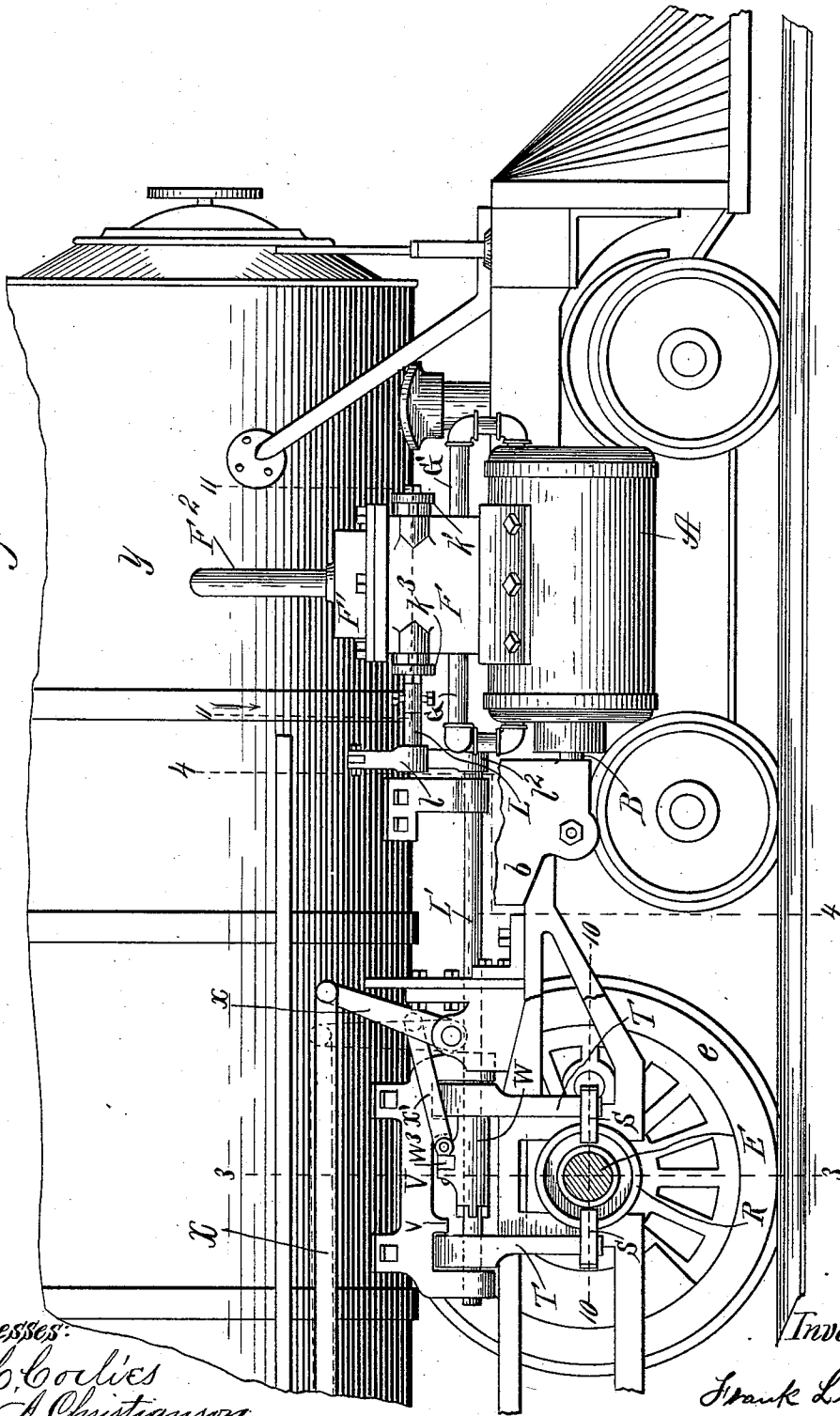

Witnesses:
W. C. Collier
Jno. A. Christianson.

Inventor:
Frank Lester

F. LESTER.
REVERSIBLE STEAM ENGINE.

No. 523,360.

Patented July 24, 1894.

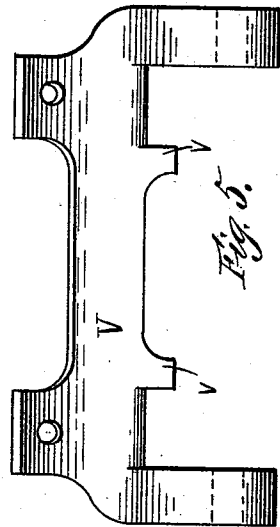
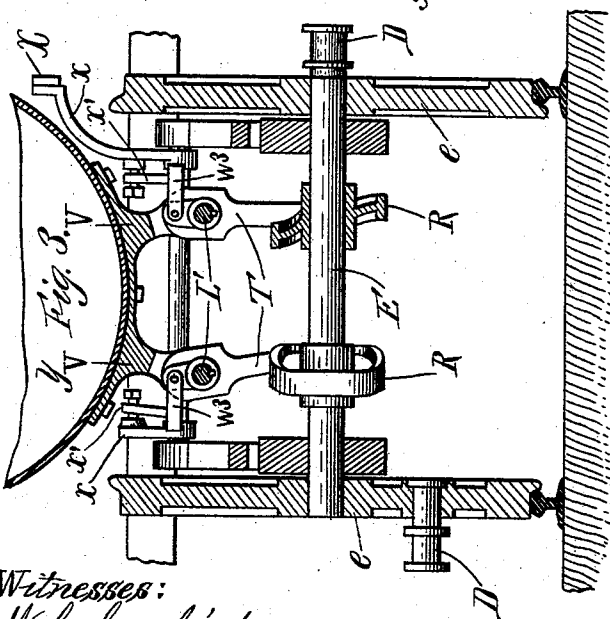
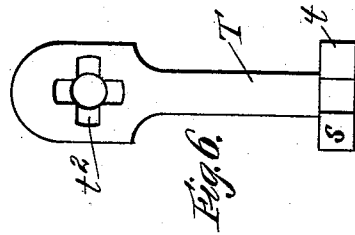
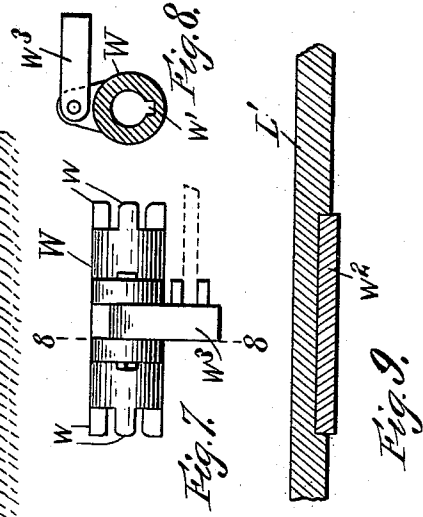
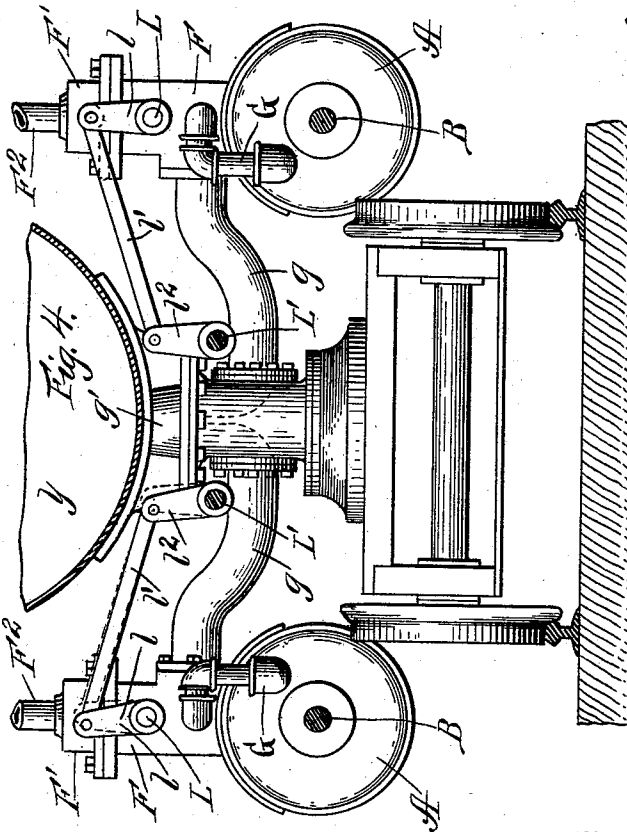

Witnesses:
W. C. Corlies
Jur. A. Christanson.

Inventor:
Frank Lester

F. LESTER.
REVERSIBLE STEAM ENGINE.

No. 523,360.

Patented July 24, 1894.

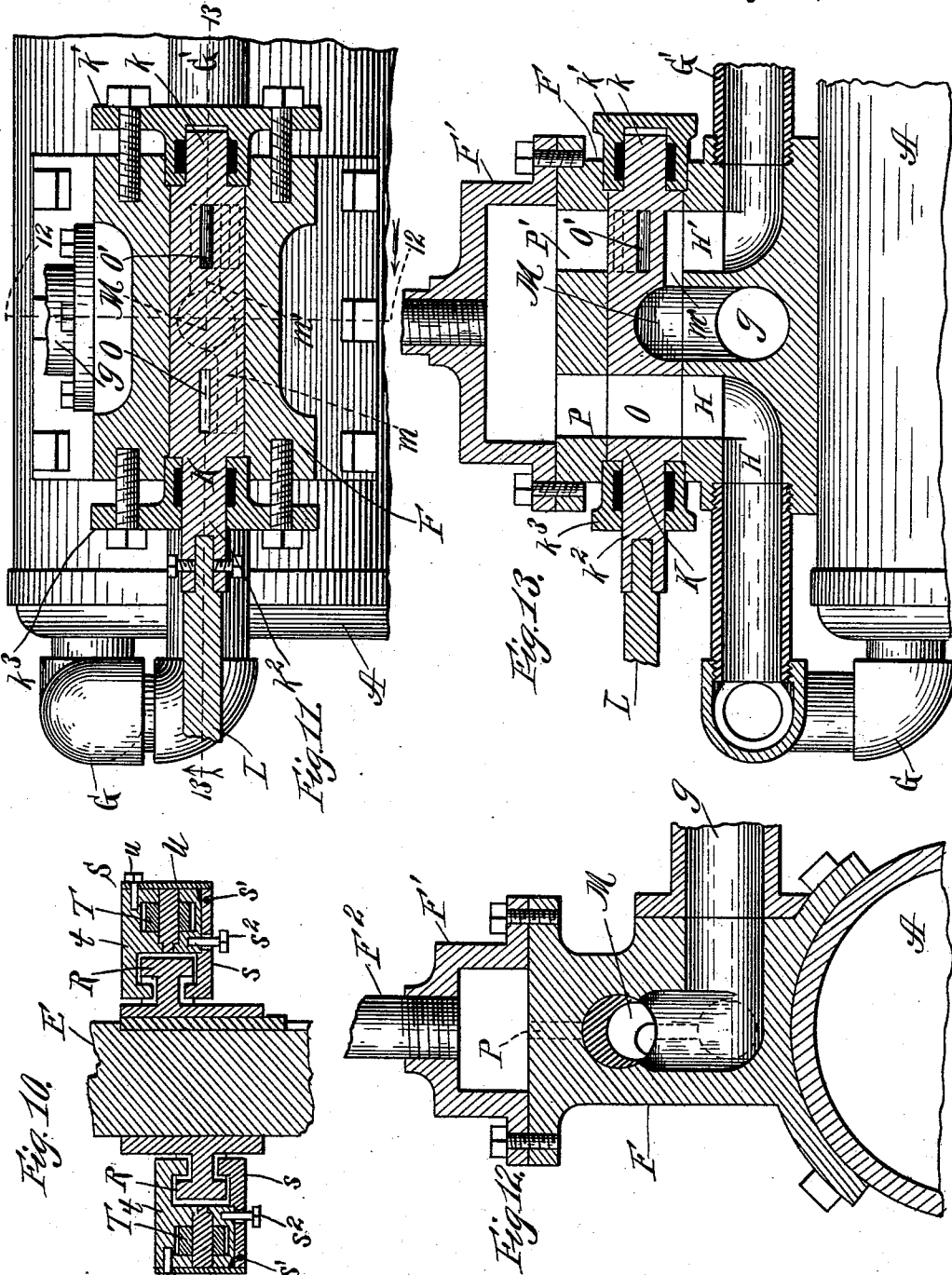

Witnesses:
W. C. Corlies
Jno. A. Christianson

Inventor:
Frank Lester

UNITED STATES PATENT OFFICE.

FRANK LESTER, OF PANHANDLE, TEXAS.

REVERSIBLE STEAM-ENGINE.

SPECIFICATION forming part of Letters Patent No. 523,360, dated July 24, 1894.

Application filed April 25, 1894. Serial No. 509,042. (No model.)

To all whom it may concern:

Be it known that I, FRANK LESTER, a citizen of the United States, residing at Panhandle, Carson county, Texas, have invented certain new and useful Improvements in Reversible Reciprocating Steam-Engines; and I do declare the following to be a full, clear, and exact description of the invention, such as will enable others skilled in the art to which it appertains to make and use the same, reference being had to the accompanying drawings, and to the letters of reference marked thereon, which form a part of this specification.

My invention relates to reversible reciprocating steam engines, its objects being to simplify the mechanism for reversing the valve, and to provide a valve in which the area of steam pressure upon its face is reduced to the minimum.

The invention consists of the use of a rocking valve separated from the steam chest and in communication with it through ports limited in capacity to the volume of steam necessary to supply the engine; of the use of a cam carried by the main shaft of the engine for the purpose of rocking the valve; of a pair of shifters mounted loosely upon a rock shaft in communication with the valve stem, and adapted to co-operate with opposite sides of the cam; and of a clutch mounted upon the rock shaft so as to turn with but slide upon it and adapted to engage either of the shifters.

The invention is adapted for use especially with locomotives.

In the accompanying drawings, Figure 1, is a side elevation of a portion of a locomotive, partly in section, in connection with which my improved valve mechanism is used. Fig. 2 is a plan view of the locomotive with the boiler removed. Fig. 3, is a transverse vertical section on the line 3—3 of Fig. 1. Fig. 4, is a similar view on the line 4—4 of Fig. 1. Figs. 5, 6, 7, 8 and 9, are details of various parts of the shifting mechanism; Fig. 8, being a transverse section on the line 8—8 of Fig. 7. Fig. 10, is a plan section on the line 10—10 of Fig. 1. Fig. 11, is a plan section on the line 11—11 of Fig. 1. Fig. 12, is a transverse vertical section on the line 12—12 of Fig. 11; and Fig. 13, is a longitudinal vertical section on the line 13—13 of Fig. 11.

The valve and its chest, the steam chest, and

the manner of introducing steam into the cylinder are the same as I have shown and described in detail in an application for patent of even date herewith and relating to stationary engines. I will not, therefore, in this application enlarge upon the functions of the various features of the valve and its immediate accessories.

The two engines used upon a locomotive being exactly alike I describe but one of them.

The cylinder, A, is of the ordinary form except that it is served with steam through pipes, G, G', leading from the valve chest and entering the cylinder through its heads. The valve stem is shown at, B, its outer end being attached to a slide block *b*, in the usual manner. The pitman or connecting rod I have omitted from the drawings in this case for the purpose of more clearly showing other parts. The crank pin is shown at D, as being set in the drive wheel *e*, mounted upon the shaft, E. The valve chest, F, is mounted upon the cylinder, A, and superimposed upon it is a steam chest, F', into which steam is conveyed by the pipe F², from the boiler, Y, of the locomotive.

The valve, K, is cylindrical in form and is housed so as to rock in a suitable chamber in the valve chest, F. To prevent the wear of the valve in its seat I provide it with a trunnion at each end as shown at, *k*, *k*², which fit within adjustable heads, *k*¹, *k*³, secured to the valve chest, F. The trunnion, *k*², projects through the block, *k*³, and to it is attached the valve stem, L.

Ducts, O, O', extend diametrically through the valve, K, their angular positions differing. Ports, P, P', lead from the chamber of the steam chest, F', to the valve and are in longitudinal alignment. Ports, H, H', lead from the valve, directly opposite, relatively, the ports, P, P', and communicate with the pipes, G, G'.

The valve, K, has an exhaust cavity, M, located between the ducts, O, O', and being at all times in communication with the exhaust port, *g*, which leads to the smoke drum of the boiler, Y, through the pipe, *g*'. Channels extend in opposite directions from the exhaust cavity, M, as indicated at, *m*, *m*', and are so disposed as to each be in longitudinal alignment with the valve ducts upon the opposite

side of the exhaust cavity, M, so that when the duct, O, opens the steam to the pipe, G, the channel, m' , opens the pipe, G' , to the exhaust. The cam, R, for shifting the valve is carried by the shaft, E, and is in wheel form. Its rim has two lateral offsets in opposite directions and diametrically opposite, the intervening portions being straight. A rock shaft L, journaled in hangers depending from a bracket, V, is connected with the valve stem, L, by means of the crank arms, l , l' , and the link, l' . The rock shaft, L' , is located above the cam, R, and a pair of arms, T, T, swing loosely upon it before opposite faces of the cam. The hangers depending from the bracket, V, are spaced apart so that the two arms, T, T, are between them and are prevented from being too widely separated. Lugs, v , v , project downwardly from the bracket, V, so as to stop the arms T, T, from approaching each other.

Each of the arms, T, T, carries a block, S, adapted to engage the rim of the cam, R, being provided with two arms, t , s , projecting toward the cam and spaced apart so as to embrace its rim, and having at their inner ends inwardly projecting lugs. The arm, s , is pivoted to the block, S, as indicated at s' , so as to swing laterally with reference to the rim of the cam. A guide pin, s^2 , projecting outwardly from the block, S, through an aperture in the arm, s , limits the movement of the latter to one direction. A spring, U, attached to the block, S, by means of the pin, u , bears against the arm, s , so as to hold it against the rim of the cam.

A clutch, W, is mounted upon the rock shaft, L' , between the arms, T, T, and is provided with an internal, longitudinal recess, w' , for engaging a spline, w^2 , carried by the rock shaft, L' . The length of the clutch, W, is less than the distance between the arms, T, T. The ends of the clutch are provided with projections, w , adapted to engage corresponding apertures in the arms, T, T. A lateral arm, w^3 , projecting from the clutch, W, is connected by a link, x' , to a swinging lever x , which is actuated by the engineer by means of the link, X, leading to the cab, not shown. By throwing the lever, x , the engineer is en-

abled to bring the clutch into engagement with either of the arms, T, T, or to disengage it from both at the same time. When the clutch, W, is in engagement with one of the arms, T, the shaft, L' , and consequently the valve, K, are rocked by the action of the cam upon that arm. By throwing the clutch, W, into engagement with the other arm, T, the movement of the valve, K, is reversed with reference to the movement of the piston, the two arms, T, T, being upon opposite sides of the shaft, E.

I claim as my invention—

1. In a reversible, reciprocating steam engine having a drive shaft, the combination with the cylinder, A, of a steam chest, a valve chest in communication with the steam chest and having lead and exhaust ports, pipes, G, G' , leading from the valve chest through the cylinder heads, a rock valve seated in the valve chest and adapted to open the pipes, G, G' , alternately to the lead and exhaust ports, a wheel cam mounted upon the drive shaft and having lateral projections, swinging arms for engaging the cam upon opposite sides of the shaft and means for bringing the arms separately into engagement with the valve substantially as described and for the purpose specified.

2. In a reversible, reciprocating engine the combination with a rock valve of a wheel cam mounted upon the engine shaft, E, and having lateral projections, a rock shaft located above the cam and being adapted to rock the valve, a pair of arms, swinging loosely from the rock shaft and engaging the cam upon opposite sides of the shaft, E, a clutch mounted and sliding upon the rock-shaft between the arms and being adapted to engage the arms separately, a spline for holding the clutch in engagement with the rock shaft, and means for shifting the clutch between the arms, substantially as described and for the purpose specified.

In testimony whereof I affix my signature in presence of two witnesses.

FRANK LESTER.

Witnesses:

B. M. BAKER,
DAN A. LEARY.