

Nov. 21, 1939.

A. A. SHINN ET AL

2,181,027

ROUTER MACHINE

Filed Feb. 26, 1938

3 Sheets-Sheet 1

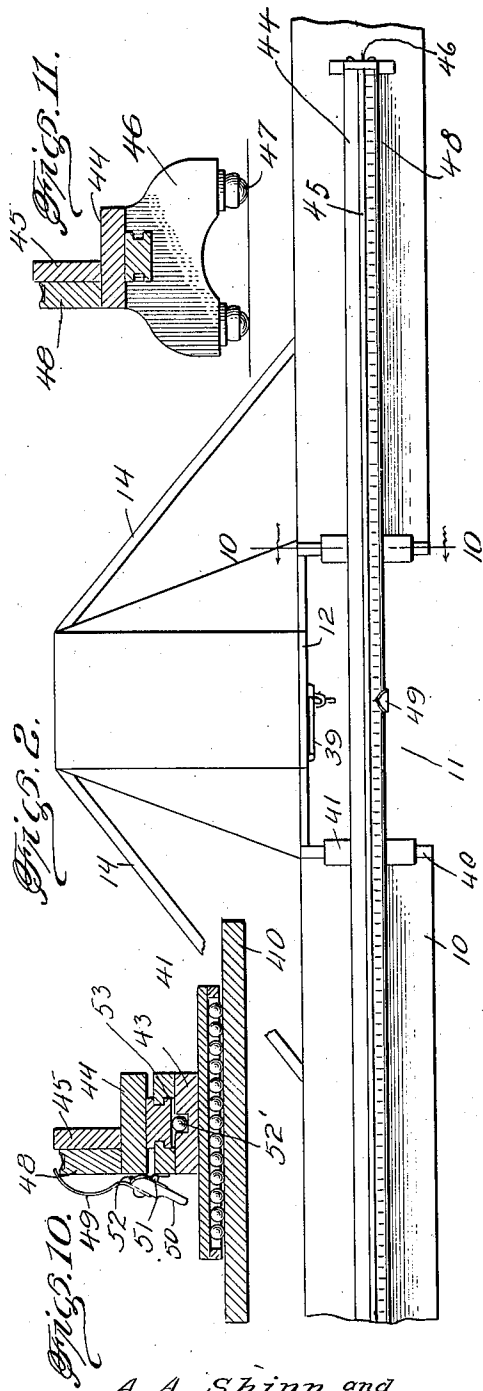
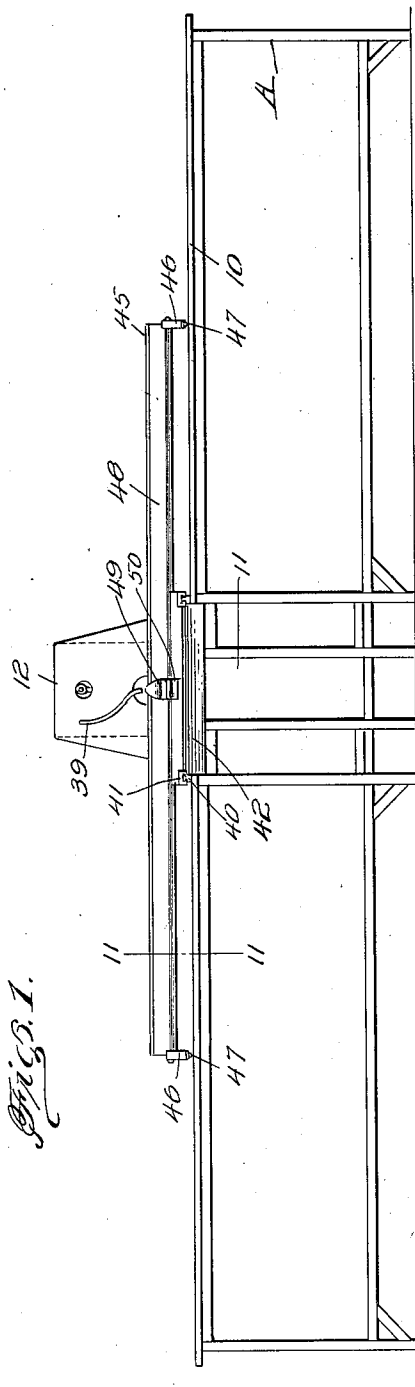

A. A. Shinn and
Don A. Ericson, INVENTOR
By Victor J. Evans & Co.
ATTORNEYS

Nov. 21, 1939.

A. A. SHINN ET AL

2,181,027

ROUTER MACHINE

Filed Feb. 26, 1938

3 Sheets-Sheet 2

Fig. 3.

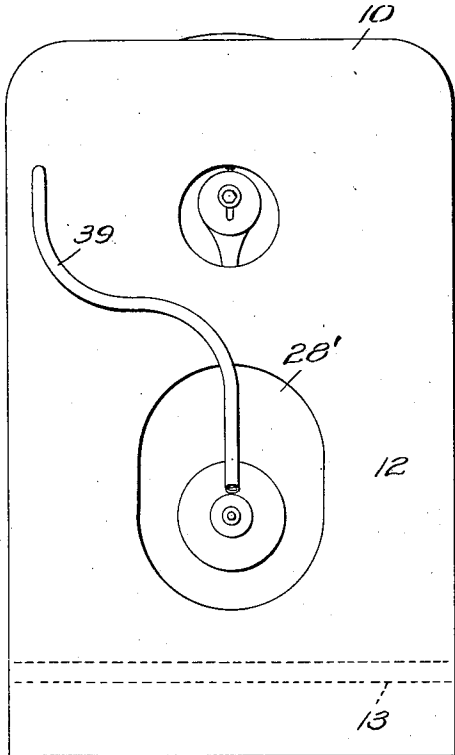

Fig. 4.

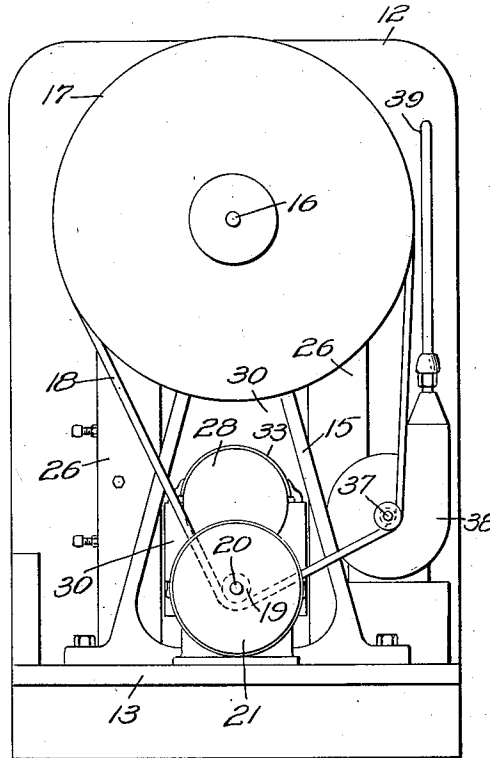

Fig. 5.

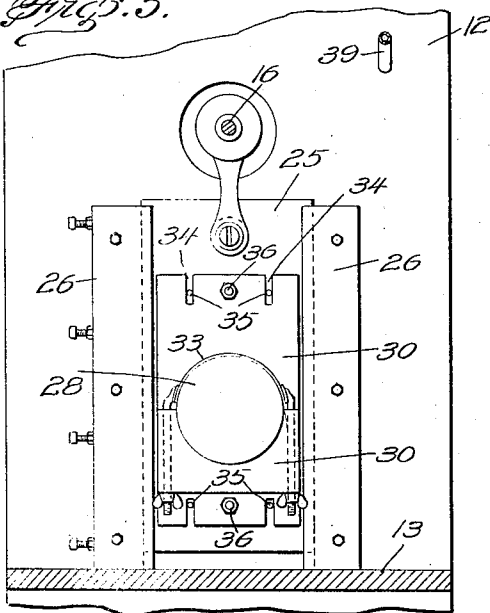

Fig. 6.

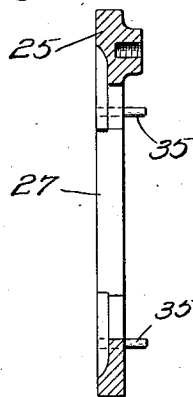
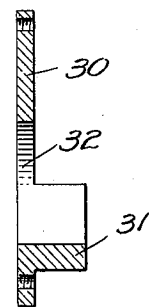

Fig. 9.



A. A. Shinn and
Don A. Ericson. INVENTOR

By Victor J. Evans & Co.

ATTORNEYS

Nov. 21, 1939.

A. A. SHINN ET AL

2,181,027

ROUTER MACHINE

Filed Feb. 26, 1938

3 Sheets-Sheet 3

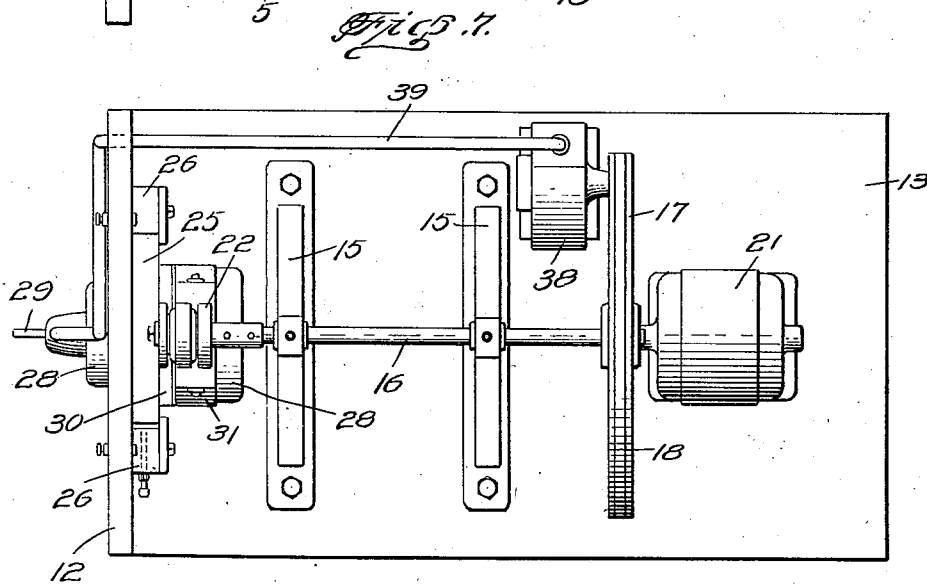
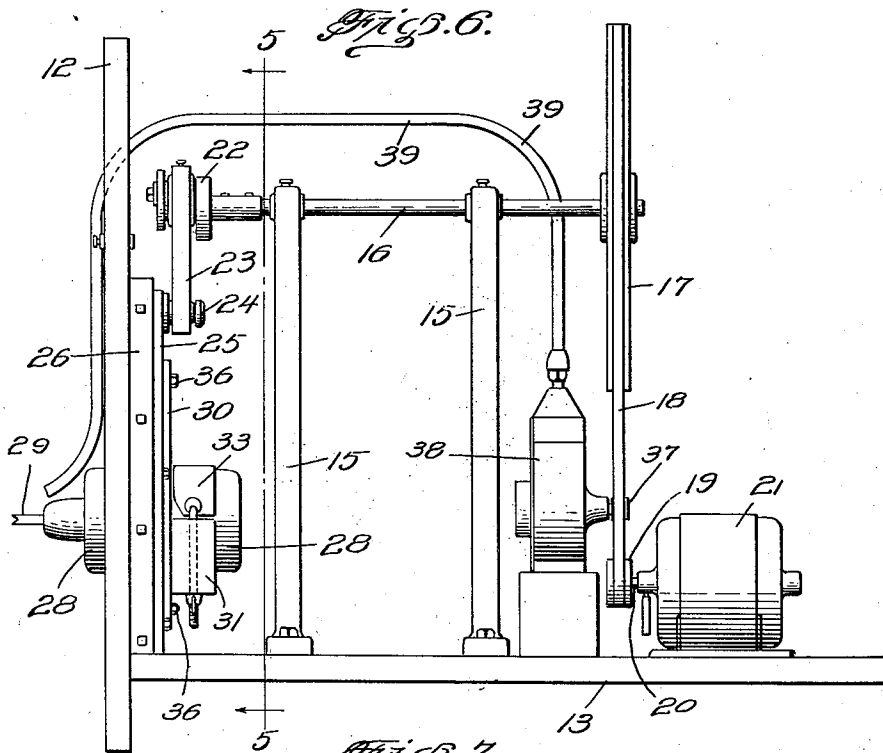

A. A. Shinn and
Don A. Erricson, INVENTOR
BY *Victor J. Evans & Co.*
ATTORNEYS

UNITED STATES PATENT OFFICE

2,181,027

ROUTER MACHINE

Alice A. Shinn and Don A. Ericson,
Oklahoma City, Okla.

Application February 26, 1938, Serial No. 192,822

6 Claims. (Cl. 90—15)

The invention relates to a routing machine and more especially to a stand and work support carried for automatic routing machines.

The primary object of the invention is the provision of a machine of this character, wherein the stand is constructed for a movable carriage on which is assembled a work support movable relative to the carriage, the carriage and the support in their construction and assembly being novel so that work to be acted upon for the routing operation of the machine can be conveniently handled during the automatic routing operation.

Another object of the invention is the provision of a machine of this character, wherein the carriage and the work support is susceptible of a wide range of adjustment for the proper handling of the work during the routing operation of the machine.

A further object of the invention is the provision of a machine of this character, wherein the construction thereof is novel in its entirety and assures the easy and convenient handling of the work for the automatic routing operation.

A further object of the invention is the provision of a machine of this character, which is simple in its construction, thoroughly reliable and efficient in operation, susceptible of the proper handling of the work for varying the extent of routing thereof in the working of the machine and inexpensive to manufacture.

With these and other objects in view, the invention consists in the features of construction, combination and arrangement of parts as will be hereinafter more fully described, illustrated in the accompanying drawings, which disclose the preferred embodiment of the invention and pointed out in the claims hereunto appended.

In the accompanying drawings:

Figure 1 is a front elevation of the machine constructed in accordance with the invention.

Figure 2 is a fragmentary top plan view thereof.

Figure 3 is an enlarged front elevation of the head or bracket for supporting the router mechanism of the machine.

Figure 4 is a rear elevation thereof with the mechanism thereon.

Figure 5 is a fragmentary sectional view taken on the line 5—5 of Figure 6 looking in the direction of the arrows.

Figure 6 is a side elevation.

Figure 7 is a top plan view of said head or bracket.

Figure 8 is an edge elevation partly in section of the slide associated with the head or bracket.

Figure 9 is a vertical sectional view through the router motor-carrying plate.

Figure 10 is a fragmentary sectional view on the line 10—10 of Figure 2 looking in the direction of the arrows.

Figure 11 is a sectional view on the line 11—11 of Figure 1.

Similar reference characters indicate corresponding parts throughout the several views in the drawings.

Referring to the drawings in detail, the machine comprises a stand A having at its top a flat horizontally disposed bed 10 being of the required length and width and has provided medially thereof a cutaway portion or recess denoted generally at 11. The cutaway portion or recess 11 is carried transversely of the bed 10 of the stand A and rearwardly in confronting relation thereto is a head or bracket involving a perpendicular frontal plate 12 and a horizontally rearwardly extending shelf 13, respectively, these being joined in any suitable manner and the shelf is sustained rigid by braces 14 diagonally disposed and associated with the stand A.

On the shelf 13 are spaced shaft hangers or bearings 15 in which is journaled a horizontally disposed driven shaft 16 having fixed thereto a belt wheel or pulley 17 over which is trained a driving belt 18 being also trained over a belt wheel or pulley 19 on a drive shaft 20 of an electric motor 21 which is stationarily carried upon the shelf 13.

The shaft 16 next to the frontal plate 12 has adjustably fitted therewith an eccentric 22 operating a throw arm 23 pivoted at 24 to a slide 25. The slide is movably fitted in spaced perpendicularly disposed guides 26, one being susceptible of taking up wear and also relieving side thrust to the said slide 25 in its operation. The slide is provided with an opening 27 for exposing there-through a portion of an electric driver 28 for a router tool, a part thereof being indicated at 29. This driver is in the form of an electric motor, the frontal plate 12 being provided with a clearance or opening 28' through which projects the driver and the tool heretofore mentioned.

The slide 25 carries a plate-like adjustable saddle part 30 having the saddle 31 and opening 32, respectively, the latter being in register with the opening 27 and the saddle 31 has fitted therein the driver 28 being held fixed in said saddle by an adjustable clamp 33. The part 30 at its upper and lower ends has provided therein slots 34, these opening through said ends and accommodate guide pins 35 fixed in the slide 25

so that the part 30 can be guided for vertical relative movement with respect to the slide 25 and such part is held in its adjusted position by fasteners 36 passed through the same and engaged in the slide 25. This part 30 through its adjustment regulates the driver 28 as to its position with respect to the slide 25, which is operated through the eccentric 22 and arm 23, respectively.

The motor 21 also through the belt 18 engaging the pulley wheel 37 operates a blower pump 38 from which leads an air tube 39, the latter being suitably trained through the frontal plate 12 for directing air under pressure to the work operated upon by the machine for the cleaning of the routed area of a piece of work during the working of the machine, this being conventional.

At opposite sides of the recess or cutaway portion 11 and elevated above the plane of the bed 10 are tracks 40 being crosswise or transversely of the said bed 10 and on which travel bearing ball equipped runners 41 of a carriage 42 fitting within the cutaway portion or recess 11 for movement toward and away from the head or bracket, that is, the frontal plate 12 thereof. This carriage 42 supports a track 43 which is disposed longitudinally of the stand A and in which is shiftably fitted a longitudinally arranged work holder 44 with relation to the said stand, which has rising therefrom a work rest rail or fence 45 being longitudinally thereof while at opposite ends of this support 44 are shoes 46 having bearing ball-like traction 47 with the top face of the bed 10 and this support 44 presents the work to the router tool 29, the depth of the routing action of the latter being controllable through the shifting of the carriage 42 while the length of the routing operation is controllable through the shifting of the support 44 when the work is thereon.

The limit of throw of the work support 44 with relation to the bed 10 of the stand A can be had in any well-known manner through the use of suitable stops (not shown) and adjustably carried by the same.

Associated with the fence 45 on the support 44 and clearly visible by an operator of the machine when looking downwardly on said support is a scale beam 48 and cooperating with the scale markings of this beam is an indicator or pointer 49 carried by a vertically movable brake arm 50 hinged at 51 to the carriage 42 centrally of its longitudinal track 43, the arm or lever 50 being provided with a braking face 52 for contact with the support 44 and holding the latter against movement on operation of the arm or lever 50 in one direction. This arm or lever 50 is manually controlled or actuated.

The carriage 42 is manually shiftably and correspondingly the support 44 for the work is manually shiftably. This support 44 operates longitudinally of the bed 10 of the stand A while the carriage 42 operates transversely of said bed, having ball bearing equipment 52' associated with the track 43 and support 44. The track and support are interfitted with each other as at 53.

The driver 28 rotatably actuates the tool 29 while the slide 25 is reciprocated under the action of the eccentric 22 and its arm 23 pivoted at 24 to said slide.

The bearings 15 are fixed to the shelf 13 in any suitable manner and also the motor 21 is stationarily supported thereon as well as the

blower or pump 38. The part 30 having the saddle 31 allows for adjustment of the driver 28 with relation to the slide 25.

The motor 21 and the driver 28, which is in the form of a motor, are stopped and started in a conventional manner, being independently controlled through hand switches (not shown) conveniently arranged in the machine.

What is claimed is:

1. In a machine of the character described, a movably supported slide having an opening therein, a saddle part having an opening for registering with the opening in the slide and also provided with a saddle beneath said opening, said saddle part having slots opening through opposite extremities thereof, guides on said slide for engaging said slots and allowing movement of the saddle part relative to said slide, and means engaging the saddle part and slide for holding the same against relative movements.

2. In a machine of the character described, a movably supported slide having an opening therein, a saddle part having an opening for registering with the opening in the slide and also provided with a saddle beneath said opening, said saddle part having slots opening through opposite extremities thereof, guides on said slide for engaging said slots and allowing movement of the saddle part relative to said slide, means engaging the saddle part and slide for holding the same against relative movements, a power driven tool fitting said saddle on the saddle part, and a loop-like clamp bridging the power driven tool and engaging the saddle for releasably clamping the said tool seated in the latter.

3. In a machine of the character described, a movably supported slide having an opening therein, a saddle part having an opening for registering with the opening in the slide and also provided with a saddle beneath said opening, said saddle part having slots opening through opposite extremities thereof, guides on said slide for engaging said slots and allowing movement of the saddle part relative to said slide, means engaging the saddle part and slide for holding the same against relative movements, a power driven tool fitting said saddle on the saddle part, a loop-like clamp bridging the power driven tool and engaging the saddle for releasably clamping the said tool seated in the later, and means having connection with the slide for imparting movement thereto.

4. In a machine of the character described, a movably supported slide having an opening therein, a saddle part having an opening for registering with the opening in the slide and also provided with a saddle beneath said opening, said saddle part having slots opening through opposite extremities thereof, guides on said slide for engaging said slots and allowing movement of the saddle part relative to said slide, means engaging the saddle part and slide for holding the same against relative movements, a power driven tool fitting said saddle on the saddle part, a loop-like clamp bridging the power driven tool and engaging the saddle for releasably clamping the said tool seated in the later, means having connection with the slide for imparting movement thereto, and means guiding the said slide in its movements.

5. In a machine of the character described, a stand having a flat horizontally disposed bed provided with a cutaway portion transversely thereof, tracks at opposite sides of the cutaway portion and elevated above the plane of the bed,

bearing ball equipped runners upon said tracks, a carriage supported by said runners and having a track disposed longitudinally of the bed, a scale beam movably associated with said last-named track and having a fence, and an indicator on said scale beam.

5
10 6. In a machine of the character described, a stand having a flat horizontally disposed bed provided with a cutaway portion transversely thereof, tracks at opposite sides of the cutaway portion and elevated above the plane of the bed,

bearing ball equipped runners upon said tracks, a carriage supported by said runners and having a track disposed longitudinally of the bed, a scale beam movably associated with said last-named track and having a fence, an indicator on said scale beam, and a brake associated with the said indicator and movable for holding the scale beam in a fixed position. 5

ALICE A. SHINN.
DON A. ERICSON. 10