



HU000034295T2

(19) **HU**(11) Lajstromszám: **E 034 295**(13) **T2****MAGYARORSZÁG**
Szellemi Tulajdon Nemzeti Hivatala**EURÓPAI SZABADALOM**
SZÖVEGÉNEK FORDÍTÁSA(21) Magyar ügyszám: **E 12 198044**(51) Int. Cl.: **E06B 3/663** (2006.01)(22) A bejelentés napja: **2012. 12. 19.****E06B 3/673** (2006.01)

(96) Az európai bejelentés bejelentési száma:

EP 20120198044

(97) Az európai bejelentés közzétételi adatai:

EP 2746518 A1 **2014. 06. 25.**

(97) Az európai szabadalom megadásának meghirdetési adatai:

EP 2746518 B1 **2017. 03. 01.**(72) Feltalálók):
Pedersen, Peter, 9800 Hjörning (DK)
Knudsen, Lars Hegelund, 9000 Aalborg (DK)(73) Jogosult(ak):
ROLLTECH A/S, 9800 Hjörning (DK)(74) Képviselő:
Olle Bäcklund, Spanga(54) **Kétrészes térköztartó átlapoló felületekkel és ilyen térköztartó gyártására szolgáló eljárás**

Az európai szabadalom ellen, megadásának az Európai Szabadalmi Közlönyben való meghirdetésétől számított kilenc hónapon belül, felszólalást lehet benyújtani az Európai Szabadalmi Hivatalnál. (Európai Szabadalmi Egyezmény 99. cikk(1))

A fordítást a szabadalmat az 1995. évi XXXIII. törvény 84/H. §-a szerint nyújtotta be. A fordítás tartalmi helyességét a Szellemi Tulajdon Nemzeti Hivatala nem vizsgálta.



(11) **EP 2 746 518 B1**

(12) **EUROPEAN PATENT SPECIFICATION**

(45) Date of publication and mention
of the grant of the patent:
01.03.2017 Bulletin 2017/09

(51) Int Cl.:
E06B 3/663^(2006.01) E06B 3/673^(2006.01)

(21) Application number: **12198044.5**

(22) Date of filing: **19.12.2012**

(54) **A two part spacer with overlapping surfaces and method of producing such a spacer**

Zweiteiliger Abstandhalter mit überlappenden Oberflächen und Verfahren zu dessen Herstellung

Espaceur en deux parties avec des surfaces de chevauchement et méthode de production

(84) Designated Contracting States:
**AL AT BE BG CH CY CZ DE DK EE ES FI FR GB
GR HR HU IE IS IT LI LT LU LV MC MK MT NL NO
PL PT RO RS SE SI SK SM TR**
Designated Extension States:
BA ME

(43) Date of publication of application:
25.06.2014 Bulletin 2014/26

(73) Proprietor: **ROLLTECH A/S
9800 Hjørring (DK)**

(72) Inventors:
• **Pedersen, Peter
9800 Hjørring (DK)**
• **Knudsen, Lars Hegelund
9000 Aalborg (DK)**

(74) Representative: **Chas. Hude A/S
H.C. Andersens Boulevard 33
1780 Copenhagen V (DK)**

(56) References cited:
**EP-A1- 1 889 995 WO-A1-01/88319
DE-U1- 9 318 934 US-A- 5 094 055
US-A- 5 714 214**

EP 2 746 518 B1

Note: Within nine months of the publication of the mention of the grant of the European patent in the European Patent Bulletin, any person may give notice to the European Patent Office of opposition to that patent, in accordance with the Implementing Regulations. Notice of opposition shall not be deemed to have been filed until the opposition fee has been paid. (Art. 99(1) European Patent Convention).

Description

Field of the Invention

[0001] The present invention relates to a spacer for forming a spacing between glass panes. The spacer comprises a top part and a lower metal foil, wherein said top part has an inner wall part with overlap surfaces at each end for connecting to said metal foil, and wherein said metal foil has an outer wall part and two lateral side-walls extending from said outer wall part, and towards said top part. The present invention further relates to a method of manufacturing a spacer and a window comprising glass panes being mutually spaced by a spacer.

Background of the Invention

[0002] It is well known to provide spacers in order to define the spacing between the panes of isolating glazings consisting of a plurality of parallel glass panes spaced by an isolating cavity.

[0003] A plurality of such spacers made of different materials and of different shapes is known in the art. Spacers made by roll forming of a metal foil are widely used in the art and considered to be one of the preferred alternatives because of their stability and their low gas diffusion properties.

[0004] Insulating Glass Units (IG units) having a plurality of glass panes are made by automatic manufacturing machines. Spacers are automatically bent to the desired size and shape and are arranged between two neighbouring glass panes. Spacers made of metal foils can be easily bent and will remain in the bent position.

[0005] Furthermore, spacers made of metal foils have a high resistance against diffusion of gases and moisture penetration. Within the space between the neighbouring glass panes, there is arranged a gas, for instance argon having good isolating properties. In order to avoid any loss of gas, the spacers delimiting the cavity need to be resistant against diffusion of such gaseous elements.

[0006] However, known spacers which are exclusively made of metal such as aluminium and galvanized steel have also some disadvantages. Due to a relatively high heat conductivity of metal, spacers made of a metal foil still have a heat conductivity which under certain circumstances may be too high.

[0007] In order to further reduce the heat conductivity, it has been suggested to use plastic material for forming such spacers. Plastic material has, however, relatively high gas diffusion as compared to metal. It thus has been suggested to provide a metal foil over a plastic body. Such a spacer is e.g. shown in EP 852 280.

[0008] A further problem of spacers made of plastic material is their instability during the manufacturing process. In particular, a spacer bent to the desired frame shape may be slightly deformed during assembly because of the resiliency of plastic material. Misalignments of the spacer during manufacturing thus are possible. In

order to avoid this problem, it has been suggested to use glass fibre reinforced plastic material in EP 852 280. Furthermore, plastics spacers including stabilising material in a plastic body have been proposed e.g. in WO 99/15753 or in WO 99/41481. However, these solutions have also some disadvantages. In particular, manufacturing is relatively complicated.

[0009] Similar spacers made from a body of plastic material are further known from DE 9 214 799, EP 1 022 424, EP 947 659 A2, EP 1 233 136 A1, WO 99/42693 or WO 03/074830. In US 5 630 306 there is disclosed an insulating spacer which comprises a main body formed of a plastic material. Metallic leg members are attached to the plastic main body. While the problem of heat conduction and diffusion can be addressed with such spacer, some problems remain in context with bending the spacer into the desired frame shape and later during assembly of an IG Unit. In particular, the lateral legs may be deformed during bending out of their plane so that an irregular shape may result. Such an irregular shape is particularly disadvantageous if a sealing contact between the spacer and a glass pane shall be achieved.

[0010] Another way of making spacers with a low heat conductivity could be by making the spacers from thin materials, thereby the amount of material is reduced but this also results in a soft and flexible spacer being difficult to handle while mounting between panes.

[0011] US 5 714 214 describes a spacer which minimises both gas diffusion and heat diffusion by combining two spacer parts from material having different properties. In US 5 714 214, two spacer parts are connected at the top with welding points positioned at the top between two folded overlaps. This is a complex solution to manufacture, both because it is a complex task to combine the two spacer parts and obtain the side overlaps, also because a welding means has to access the space between the two overlap parts for welding the welding points, and finally the subsequent bending of the spacer into a desired frame shape will deform the spacer in a manner which may weaken the weldings.

[0012] US 5 714 214 thereby discloses all the features of the preamble of independent claim 1.

Object of the Invention

[0013] It is therefore an object of the present invention to provide a spacer with an increased stiffness and solving the above mentioned problems.

Description of the Invention

[0014] This is obtained by a spacer for forming a spacing between glass panes, with all the features of claim 1.

[0015] By having overlapping regions at the side walls the spacer is stiffened because of this overlap, thereby spacers can be produced of quite thin material e.g. where also the top part is made from a metal foil. The overlapping region at both side of the spacer ensures a stiffer

spacer which can be handled easier. Further by fastening the overlapping surfaces close to the top part, when attaching the spacer between panes the used attachment material e.g. butyl ensures that the attachment is sealed. It is thereby ensured that gas from between the windows cannot pass the spacer through the connection between the top part and the lower metal foil. Further overlapping is present at both sides of the spacer and this also introduces a quite stiff spacer, even if the spacer is made from a thin material.

[0016] In an embodiment said top part further comprises a second overlap surface at each end, whereby said overlap surfaces at each end of said sidewalls of said metal foil are mutually fastened between said first and second overlap surface at each end of said inner wall part. Thereby a better fastening can be obtained between the two parts of the spacer, the metal foil overlap surfaces at the end of sidewalls are sandwiched between the first and second overlap surface at each end of the inner wall part.

[0017] The spacer further comprises overlap surfaces being substantially parallel to the inner wall part of said top part. Thereby the spacer is further strengthened.

[0018] In another embodiment the overlap surfaces are substantially parallel to the lateral sidewalls of said metal foil. Thereby the top part and metal foil are easy to assemble for specific assembling methods.

[0019] In an embodiment the top part is made of metal foil. Thereby the spacer becomes very resistant to gas diffusion.

[0020] In an embodiment the top part is made of a plastic material. Thereby heat conductivity is reduced.

[0021] In an embodiment said overlapping surfaces are mutually fastened by welding. This has been proven to be a very efficient way of fastening, where the overlap can be mutually fastened by spot welding from one side of the overlapping surfaces.

[0022] In an embodiment said overlapping surfaces are mutually fastened by gluing.

[0023] The invention further relates to a method of producing such a spacer for forming a spacing between glass panes, comprising the steps of:

- Providing an elongated top part having overlap surfaces at each end for connecting to a metal foil,
- Providing a metal foil with sidewalls having overlap surfaces,
- Attaching said metal foil and said top part to each other in such a way that the overlap surfaces at each end of the elongated top part and the overlap surfaces of the sidewalls of the metal foil are overlapping, and mutually fastening said overlap surfaces, wherein an end of an overlap surface overlapping another overlap surface is present at the outer surface on each side of said spacer.

[0024] The invention further relates to a window comprising glass panes being mutually spaced by a spacer

according to the invention.

Description of the Drawing

5 **[0025]** In the following embodiments of the present invention will be described referring to the figures, wherein

figure 1 illustrates a sectional view of an embodiment of a spacer according to the present invention,

10

figure 2 illustrates a sectional view of the spacer of figure 1 mounted between panes,

15

figure 3-5 illustrates a sectional view of alternative embodiments of the spacer according to the present invention.

Detailed Description of the Invention

20 **[0026]** Figure 1 illustrates a sectional view of an embodiment of a spacer 101 for forming a spacing between panes according to the present invention. The spacer 101 comprises a top part 103 and a lower metal foil 105.

[0027] The top part 103 has an inner wall part 107 with corresponding overlap surfaces at each side being respectively 109, 112 and 110, 111 at each end for connecting to the lower metal foil 105. The top part can be in a thin material being either metal or plastic and could either be made by bending or extrusion. The material chosen influences both heat conductivity and the ability to resist gas diffusion.

[0028] The lower metal foil 105 has an outer wall part 113 and two lateral legs or sidewalls 115, 117 extending from the outer wall part 113 and towards the top part 103.

25 Each end of said lateral side walls 115, 117 comprises an overlap surface 119 at one side and 121 at the other side being parallel to each overlap surface 109, 111 of the top part 103. The overlap surfaces of respectively the top part and the lower metal foil are substantially parallel

30 to the lateral sidewalls 115, 117 of the metal foil 105 and thereby the side of the spacer ends up having layers of material at each side (in this example three layers) the layers in one side being 111, 119, 110 and in the other side being 112, 121, 109. By having these layers it is possible to make the spacers from quite thin materials e.g. metal foils and still obtain a stiff spacer, the stiffness caused by the overlapping.

35 **[0029]** As can be seen from the figure, the overlapping area are quite close to the inner wall and in the top part of the spacer and thereby the overlap surfaces can be mutually fastened in a region closer to the inner wall part than the outer wall part.

[0030] In figure 2 a sectional view of the spacer 101 of figure 1 mounted between panes 201, 203 are illustrated. The spacer is mounted to the panes using a fastening material 205, 207 being e.g. butyl or another material being suitable for connecting the materials of respectively the sides of the spacer and the panes, further the fasten-

40 45 50 55

ing material should resist gas diffusion. The fastening material is below the overlapping area (encircled area 209, 211) where the two parts are fastened and thereby the only way gas can get from between the two panes 201, 203 and out is through the lower metal foil 113 or through the fastening material 205, 207.

[0031] In figure 3 an alternative embodiment where only two layers are overlapping parallel to the side walls (encircled areas 209, 211). In this embodiment further overlapping surfaces are present being substantially parallel with the inner wall of the top part.

[0032] These further surfaces are illustrated by respectively 305 and 301 on the lower metal part 105 and 303 and 307 on the top part 103. Thereby the spacer is further strengthened.

[0033] In figure 4 another embodiment is illustrated where two layers are overlapping parallel to the side walls (encircled areas 209, 211). In this embodiment the top part has been bended having peaks 401, 403. It is thereby possible to obtain a larger overlapping area at the top part of the spacer and thereby a better attachment of the two parts. Further the shaping of the spacer is optimised for influencing the bending properties of the spacer when bending to fit the geometry of the panes.

[0034] In figure 5 another embodiment of the spacer is illustrated where two layers are overlapping parallel to the side walls (encircled areas 209, 211). In this embodiment both peaks 401, 403 are present as well as a further overlapping being substantially parallel with the inner wall of the top part illustrated by respectively 305 and 301 on the lower metal part and 303 and 307 on the top part.

Claims

1. A spacer (101) for forming a spacing between glass panes (201, 203), with a top part (103) and a lower metal foil (105), wherein said top part (103) has an inner wall part (107) with overlap surfaces (110, 111, 109, 112) at each end for connecting to said metal foil (105), and wherein said metal foil (105) has an outer wall part (113) and two lateral sidewalls (115, 117) extending from said outer wall part (113), and towards said top part (103) wherein each end of said lateral side walls (115, 117) comprises an overlap surface (119, 121) parallel to each overlap surface (109, 111) of said top part (103), **characterised in that,** the overlap surfaces (110, 111, 119, 109, 112, 121) are substantially parallel to the lateral sidewalls (115, 117) of said metal foil (105) and wherein said overlap surfaces (119, 111) are overlapping in an overlapping area (209, 211) in the top part of the spacer for mutually fastening in a region closer to the inner wall part (107) than the outer wall part (113), whereby

fastening material for connecting the sides of the spacer and the panes can be positioned below the overlapping area and wherein the overlap surfaces in said overlap area are positioned for mutually fastening, e.g. by spot welding, from one side of said overlapping surfaces.

2. A spacer according to claim 1, wherein said top part (103) further comprises a second overlap surface (110, 112) at each end, whereby said overlap surfaces (119, 121) at each end of said sidewalls (115, 117) of said metal foil (105) are mutually fastened between said first (110, 112) and second (109, 111) overlap surface at each end of said inner wall part (107).
3. A spacer according to claim 1-2, wherein the spacer further comprises overlap surfaces (301, 303, 305, 307) being substantially parallel to the inner wall part (107) of said top part (103).
4. A spacer according to claim 1-3, wherein the top part is made of metal foil.
5. A spacer according to claim 1-4, wherein the top part is made of a plastic material.
6. A spacer according to claim 1-5, wherein said overlapping surfaces are mutually fastened by welding.
7. A spacer according to claim 1-5, wherein said overlapping surfaces are mutually fastened by gluing.
8. A method of producing a spacer (101) for forming a spacing between glass panes (201, 203), for a spacer according to any of the claims 1 to 7, comprising the steps of:
 - Providing an elongated top part having overlap surfaces at each end for connecting to a metal foil,
 - Providing a metal foil with sidewalls having overlap surfaces,
 - Attaching said metal foil and said top part to each other in such a way that the overlap surfaces at each end of the elongated top part and the overlap surfaces of the sidewalls of the metal foil are overlapping, and mutually fastening said overlap surfaces.
9. A window comprising glass panes (201, 203) being mutually spaced by a spacer (101) according to any of the claims 1 to 7.

Patentansprüche

1. Ein Abstandshalter (101) zum Bilden eines Abstands

- zwischen Glasscheiben (201, 203) mit einem oberen Teil (103) und einer unteren Metallfolie (105), wobei jener obere Teil (103) einen inneren Wand-Teil (107) mit Überlappungs-Oberflächen (110, 111, 109, 112) an jedem Ende hat, zur Verbindung mit jener Metall-Folie (105), und wobei jene Metallfolie (105) einen äußeren Wand-Teil (113) und zwei laterale Seitenwände (115, 117) hat, die sich von jenem äußeren Wand-Teil (113) und in Richtung jenes oberen Teils (103) erstrecken, wobei jedes Ende jener lateralen Seitenwände (115, 117) eine Überlappungs-Oberfläche (119, 121) umfasst, die parallel zu jeder Überlappungs-Oberfläche (109, 111) jenes oberen Teils (103) ist, dadurch charakterisiert, dass die Überlappungs-Oberflächen (110, 111, 119, 109, 112, 121) im Wesentlichen parallel zu den lateralen Seitenwänden (115, 117) jener Metallfolie (105) sind und wobei jene Überlappungs-Oberflächen (119, 111) in einem überlappenden Bereich (209, 211) im oberen Bereich des Abstandshalters überlappen, zum wechselseitigen Befestigen in einem Bereich, der näher zum inneren Wand-Teil (107) als zum äußeren Wand-Teil (113) ist, wodurch befestigendes Material zum Verbinden der Seiten des Abstandshalters und der Scheiben unter dem überlappenden Bereich positioniert werden kann und wobei die Überlappungs-Oberflächen in jenem Überlappungs-Bereich zum wechselseitigen Befestigen, z.B. durch Punktschweißen, von einer Seite jener überlappenden Oberflächen positioniert sind.
2. Ein Abstandshalter entsprechend Anspruch 1, wobei jenes obere Teil (103) außerdem eine zweite Überlappungs-Oberfläche (110, 112) an jedem Ende umfasst, wodurch jene Überlappungs-Oberflächen (119, 121) an jedem Ende jener Seitenwände (115, 117) jener Metallfolie (105) wechselseitig zwischen jener ersten (110, 112) und zweiten (109, 111) Überlappungs-Oberfläche an jedem Ende jenes inneren Wand-Teils (107) befestigt sind.
 3. Ein Abstandshalter gemäß Anspruch 1-2, wobei der Abstandshalter außerdem Überlappungs-Oberflächen (301, 303, 305, 307) umfasst, die im Wesentlichen parallel zum inneren Wand-Teil (107) jenes oberen Teils (103) sind.
 4. Ein Abstandshalter gemäß Anspruch 1-3, wobei der obere Teil aus Metallfolie gemacht ist.
 5. Ein Abstandshalter gemäß Anspruch 1-4, wobei der obere Teil aus einem PlastikMaterial gemacht ist.
 6. Ein Abstandshalter gemäß Anspruch 1-5, wobei jene überlappenden Oberflächen wechselseitig durch Schweißen befestigt sind.
 7. Ein Abstandshalter gemäß Anspruch 1-5, wobei jene überlappenden Oberflächen wechselseitig durch Kleben befestigt sind.
 8. Ein Verfahren zur Herstellung eines Abstandshalters (101) zum Bilden eines Abstands zwischen Glasscheiben (201, 203) für einen Abstandshalter gemäß einem der Ansprüche 1 bis 7, umfassend die Schritte von:
 - Bereitstellen eines länglichen oberen Teils mit Überlappungs-Oberflächen an jedem Ende zum Verbinden mit einer Metallfolie,
 - Bereitstellen einer Metallfolie mit Seitenwänden mit Überlappungs-Oberflächen,
 - Aneinanderfügen jener Metallfolie und jenes oberen Teils, sodass die Überlappungs-Oberflächen an jedem Ende des länglichen oberen Teils und die Überlappungs-Oberflächen der Seitenwände der Metallfolie überlappen, und wechselseitiges Befestigen jener Überlappungs-Oberflächen.
 9. Ein Fenster, umfassend Glasscheiben (201, 203), die wechselseitig durch einen Abstandshalter (101) gemäß einem der Ansprüche 1 bis 7 auf Abstand gehalten werden.
- 30 Revendications**
1. Entretoise (101) destinée à former un espacement entre des vitres (201, 203), avec une partie supérieure (103) et une feuille métallique inférieure (105), dans laquelle ladite partie supérieure (103) possède une partie formant paroi interne (107) avec des surfaces de chevauchement (110, 111, 109, 112) à chaque extrémité destinées à être reliées à ladite feuille métallique (105), et dans laquelle ladite feuille métallique (105) possède une partie formant paroi externe (113) et deux parois latérales (115, 117) s'étendant à partir de ladite partie formant paroi externe (113) et vers ladite partie supérieure (103), dans laquelle chaque extrémité desdites parois latérales (115, 117) comprend une surface de chevauchement (119, 121) parallèle à chaque surface de chevauchement (109, 111) de ladite partie supérieure (103), **caractérisée en ce que,** les surfaces de chevauchement (110, 111, 119, 109, 112, 121) sont sensiblement parallèles aux parois latérales (115, 117) de ladite feuille métallique (105) et dans laquelle lesdites surfaces de chevauchement (119, 111) se chevauchent dans une zone de chevauchement (209, 211) de la partie supérieure de l'entretoise pour être mutuellement fixées dans une région plus proche de la partie formant paroi

- interne (107) que de la partie formant paroi externe (113), moyennant quoi un matériau de fixation destiné à relier les côtés de l'entretoise et les vitres peut être placé sous la zone de chevauchement et dans laquelle les surfaces de chevauchement de ladite zone de chevauchement sont placées de manière à être mutuellement fixées, par exemple par soudage par point, à partir d'un côté desdites surfaces de chevauchement. 5
2. Entretoise selon la revendication 1, dans laquelle ladite partie supérieure (103) comprend en outre une seconde surface de chevauchement (110, 112) à chaque extrémité, moyennant quoi lesdites surfaces de chevauchement (119, 121) à chaque extrémité desdites parois latérales (115, 117) de ladite feuille métallique (105) sont mutuellement fixées entre ladite première (110, 112) et ladite seconde (109, 111) surface de chevauchement à chaque extrémité de ladite partie formant paroi interne (107). 10 15 20
3. Entretoise selon les revendications 1 à 2, dans laquelle l'entretoise comprend en outre des surfaces de chevauchement (301, 303, 305, 307) qui sont sensiblement parallèles à la partie formant paroi interne (107) de ladite partie supérieure (103). 25
4. Entretoise selon les revendications 1 à 3, dans laquelle la partie supérieure est faite d'une feuille métallique. 30
5. Entretoise selon les revendications 1 à 4, dans laquelle la partie supérieure est faite d'une matière plastique. 35
6. Entretoise selon les revendications 1 à 5, dans laquelle lesdites surfaces de chevauchement sont mutuellement fixées par soudage.
7. Entretoise selon les revendications 1 à 5, dans laquelle lesdites surfaces de chevauchement sont mutuellement fixées par collage. 40
8. Procédé de fabrication d'une entretoise (101) destinée à former un espacement entre des vitres (201, 203), pour une entretoise selon l'une quelconque des revendications 1 à 7, comprenant les étapes suivantes : 45
- la fourniture d'une partie supérieure allongée ayant des surfaces de chevauchement à chaque extrémité destinée à être reliées à une feuille métallique, 50
 - la fourniture d'une feuille métallique avec des parois latérales ayant des surfaces de chevauchement, 55
 - la fixation de ladite feuille métallique et de ladite partie supérieure de telle manière que les sur-
- faces de chevauchement à chaque extrémité de la partie supérieure allongée et les surfaces de chevauchement des parois latérales de la feuille métallique se chevauchent, et la fixation mutuelle desdites surfaces de chevauchement.
9. Fenêtre comprenant des vitres (201, 203) qui sont mutuellement espacées par une entretoise (101) selon l'une quelconque des revendications 1 à 7.

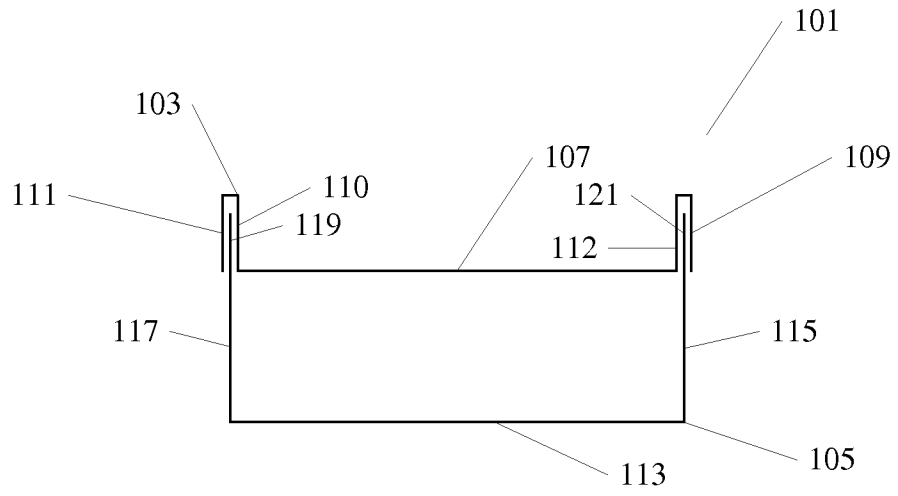

Fig. 1

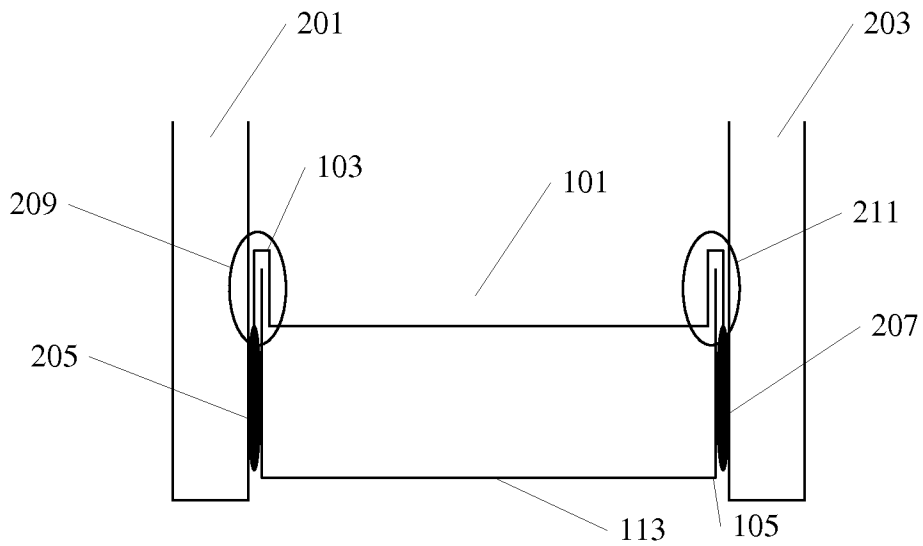

Fig. 2

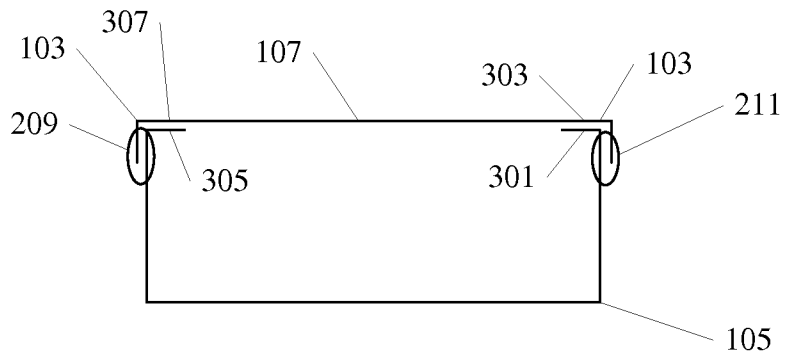

Fig. 3

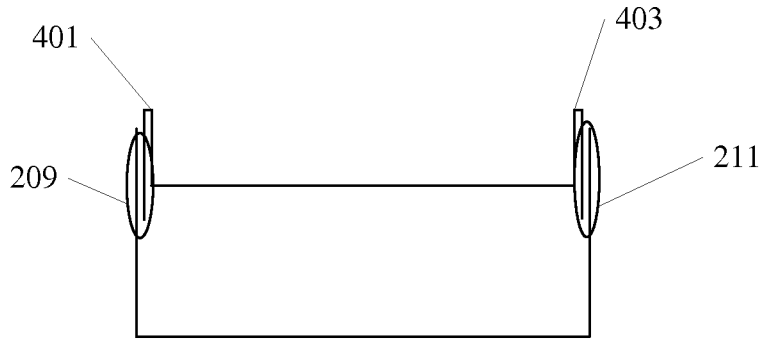

Fig. 4

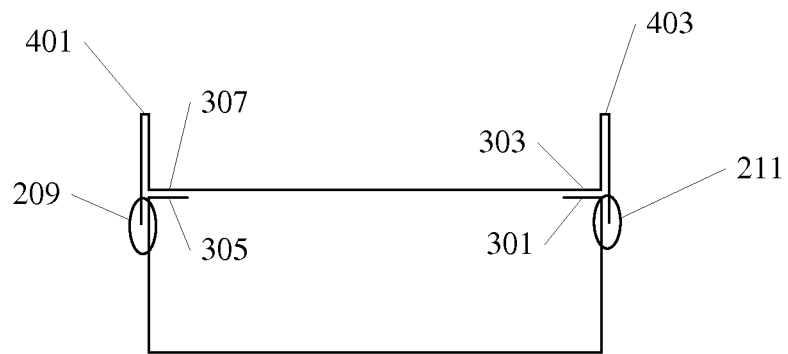

Fig. 5

REFERENCES CITED IN THE DESCRIPTION

This list of references cited by the applicant is for the reader's convenience only. It does not form part of the European patent document. Even though great care has been taken in compiling the references, errors or omissions cannot be excluded and the EPO disclaims all liability in this regard.

Patent documents cited in the description

- EP 852280 A [0007] [0008]
- WO 9915753 A [0008]
- WO 9941481 A [0008]
- DE 9214799 [0009]
- EP 1022424 A [0009]
- EP 947659 A2 [0009]
- EP 1233136 A1 [0009]
- WO 9942693 A [0009]
- WO 03074830 A [0009]
- US 5630306 A [0009]
- US 5714214 A [0011] [0012]

SZABADALMI IGÉNYPONTOK

1. Térköztartó (101) üvegtáblák (201, 203) közötti térköz létrehozásához, amely térköztartó rendelkezik egy felső résszel (103) és egy alsó fémfóliával (105),
5 amely felső résznek (103) van egy belső falrésze (107) mindkét végén átlapoló felületekkel (110, 111, 109, 112) a fémfóliához (105) való kapcsolódás céljából, amely fémfóliának (105) van egy külső falrésze (113) és két oldalsó oldalfala (115, 117), amelyek a külső falrésztől (113) a felső rész (103) felé terjednek ki, amely oldalsó oldalfalak (115, 117) mindkét vége magában foglal egy-egy, a
10 felső rész (103) átlapoló felületeivel (109, 111) párhuzamos átlapoló felületet (119, 121),
azzal jellemezve, hogy az átlapoló felületek (110, 111, 119, 109, 112, 121) nagyjából párhuzamosak a fémfólia (105) oldalsó oldalfalaival (115, 117), és az átlapoló felületek (119, 111) egy, a térköztartó felső részén lévő átlapolási területen (209,
15 211) átlapolnak, hogy kölcsönösen rögzítsék egymást egy olyan helyen, amely közelebb van a belső falrészhez (107), mint a külső falrészhez (113), miáltal a térköztartó oldalai és az üvegtáblák összekötésére szolgáló rögzítőanyagot el lehet helyezni az átlapolási terület alatt, és az átlapoló felületek az átlapoló területen kölcsönös rögzítéshez vannak elhelyezve, amely rögzítés például ponthegesztéssel történik az
20 átlapolási felületek egyik oldaláról.
2. Az 1. igénypont szerinti térköztartó, amelyben a felső rész (103) magában foglal továbbá egy második átlapoló felületet (110, 112) mindkét végén, miáltal az átlapoló felületek (119, 121) a fémfólia (105) oldalfalainak (115, 117) mindkét végén
25 a belső falrész (107) két végén lévő első (110, 112) és második (109, 111) átlapoló felület között vannak kölcsönösen rögzítve.
3. Az 1. és a 2. igénypont szerinti térköztartó, amely térköztartó magában foglal továbbá átlapoló felületeket (301, 303, 305, 307), amelyek nagyjából párhuzamosak a felső rész (103) belső falrészével (107).
30
4. Az 1-3. igénypontok szerinti térköztartó, amelyben a felső rész fémfóliából készül.
- 35 5. Az 1-4. igénypontok szerinti térköztartó, amelyben a felső rész műanyagból készül.
6. Az 1-5. igénypontok szerinti térköztartó, amelyben az átlapolási felületek



hegesztéssel vannak kölcsönösen rögzítve.

7. Az 1-5. igénypontok szerinti térköztartó, amelyben az átlapolási felületek ragasztással vannak kölcsönösen rögzítve.

5

8. Eljárás egy, az 1-7. igénypontok bármelyike szerinti térköztartó (101) gyártására üvegtáblák (201, 203) közötti térköz létrehozásához, amely eljárás magában foglalja a következő lépéseket:

- rendelkezésre bocsátunk egy hosszúkás felső részt, amelynek mindkét végén 10 átlapoló felületek vannak egy fémfóliához való kapcsolódás céljából,
- rendelkezésre bocsátunk egy fémfóliát oldalfalakkal, amelyeknek átlapoló felületei vannak,
- egymáshoz erősítjük a fémfóliát és a felső részt oly módon, hogy a hosszúkás felső rész két végén lévő átlapoló felületek és a fémfólia oldalfalainak átlapoló felületei 15 átlapolnak, és kölcsönösen rögzítik az átlapoló felületeket.

9. A biak olyan üvegtáblákból (201, 203), amelyeket kölcsönösen bizonyos távolságban tart egy, az 1-7. igénypontok bármelyike szerinti térköztartó (101).

39
