



Europäisches Patentamt
European Patent Office
Office européen des brevets



Publication number: **0 464 383 A2**

EUROPEAN PATENT APPLICATION

Application number: **91109114.8**

Int. Cl.⁵: **H01J 3/02**

Date of filing: **04.06.91**

Priority: **26.06.90 SU 4843045**

Date of publication of application:
08.01.92 Bulletin 92/02

Designated Contracting States:
AT CH DE FR GB IT LI NL

Applicant: **HAUZER TECHNO COATING
EUROPE BV
Groethofstraat 22 b
NL-5916 PB Venlo(NL)**

Inventor: **Alexeevich, Arkhipov Boris
ul. Kommunisticheskaya, 12, kv.2
236000 Kaliningrad-obl.(SU)
Inventor: Mitrofanovich, Gorbachev Yuriy
ul. Kommunisticheskaya, d.58B, kv.7**

**236005 Kaliningrad-obl.(SU)
Inventor: Alexeevich, Ivanov Viktor
ul. Frunze, d.75, kv.16
236006 Kaliningrad-obl.(SU)
Inventor: Nikolaevich, Kozubsky Konstantin
ul. Frunze, d.34, kv.24
236006 Kaliningrad-obl.(SU)
Inventor: Alexeevich, Komarov Georgy
ul. Chaadaeva, d.27, kv.25
236039 Kaliningrad-obl.(SU)**

Representative: **Dipl.-Phys.Dr. Manitz
Dipl.-Ing.Dipl.-Wirtsch.-Ing. Finsterwald
Dipl.-Phys. Rotermund Dipl.-Chem.Dr. Heyn
B.Sc.(Phys.) Morgan
Robert-Koch-Strasse 1
W-8000 München 22(DE)**

Plasma neutralisation cathode.

A plasma compensation cathode comprises a casing (1) accommodating coaxially with its outlet hole (2) a hollow holder (3) and a thermal emitter (4) with a central passage (5), a layer (10) of material chemically inert at high temperatures to the materials of the holder and emitter being interposed therebetween. The central passage (5) is blind at the side of admission of gas, and is communicated with the interior of the holder (3) by way of a through passage (8) made in the wall of the thermal emitter (4) so that its axis intersects the axis of passage (5), and longitudinal grooves (9) made in the side surface of the thermal emitter (4) at the location of the inlet holes of the through passage (8). The holder (3) is embraced by heater (6) having a support ring (7) positioned in its midportion and secured in an insulation sleeve (18) separating the heater (6) from the coaxial heat screens (11) interconnected successively to define a sealed cavity (14) wherethrough the interior of the holder (3) communicates with the gas feeding pipe (13) secured in the casing (1) through the support insulator (17). Interposed between mechanical filters (16) and between holder (3) and pipe (13) is a getter (15).

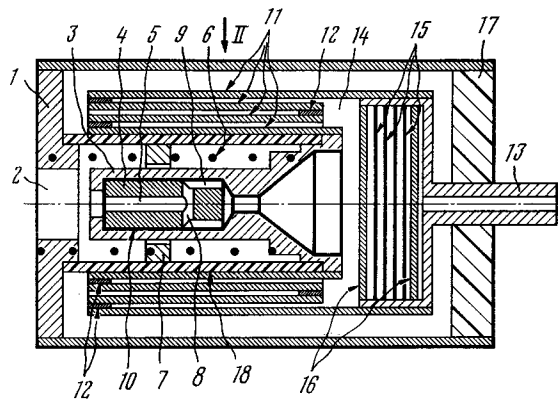

FIG. 1

EP 0 464 383 A2

Field of the Invention

This invention relates generally to glowing compensation cathodes, and more particularly to plasma compensation cathodes.

Background of the Invention

There is known a glowing cathode (cf., Schats M.F. "Heaterless Ignition of Inert Gas. Ion Thruster Hollow Cathodes" AJAA Paper, 1985) comprising a casing a cylindrical insert secured to the inner surface of the casing and functioning as thermal emitter, a heater secured at the outer side of the casing, and an orifice secured to end face of the casing and acting as the outlet hole of the cathode. This construction of cathode requires high power heaters to heat thermal emitter to a temperature ensuring thermoionic emission sufficient for maintaining a stable discharge.

There is also known a plasma compensation cathode (cf., L.A. Artsimovich, et al "Razrabotka stacionarnogo plazmennogo dvigatelya i ego ispytanie na iskusstvennom sputnike Zemli Meteor", Kosmicheskie issledovania, 1974, tom XII, vyp. 3, pages 455 and 456, Fig. 5). This compensation cathode has a casing with an outlet hole at one wall thereof, the casing accommodating coaxially to its outlet hole a tubular holder receiving a thermal emitter with a central through passage. The compensation cathode also includes a heater embracing the tubular holder, and heat screens positioned between the holder and casing walls. Connected to the tubular holder is a pipe for feeding gas to the interior of the casing and to the passage of thermal emitter through its inlet portion. This pipe is secured in the casing through an insulator.

During operation of the compensation cathode gas is conveyed through the tubular holder to the passage of the thermal emitter. Heated to a high temperature, the thermal emitter ensures emission of electrons sufficient for maintaining stable electric discharge between the inner surface of the thermal emitter and anode of the plasma source. After bringing the device to steady-state operation conditions the heater is deenergized, and the compensation cathode continues to operate automatically, whereby the preferred temperature level is ensured by the energy liberated in the catholyte layer approximating to the product of ionic current resulting from discharge by the potential drop at the cathode. However, in the course of operation the discharge can move from the passage of thermal emitter to the interior of tubular holder resulting in evaporation of the material of the holder and fouling of the passage with holder material to almost complete clogging. As a result, thermoemis-

sion surfaces tend to degrade, and thermoemission current tends to decrease thereby reducing the service life of the compensation cathode to only tens of hours. In addition, direct connection of the holder of thermal emitter to the gas feeding pipe leads to vigorous heat transfer from the emitter to outer structural parts, and consequently to move prominent catholyte potential drop ensuring the energy necessary for maintaining automatic operating conditions. More prominent catholyte potential drop also leads to reduced service life of the thermal emitter because of intensified ionic bombardment. In addition, tight contact of thermoemissive materials with the holder at high working temperatures is accompanied by active chemical interaction, such as penetration of boron followed by formation of metal borides, which in turn causes embrittlement and cracking of the holder material and thermal emitter to result in irreversible deformation of the holder. This disadvantageous effect is especially pronounced at starting operating conditions accompanied by the highest temperature levels, which limits the service life and reduces the total number of engagements of the compensation cathode. Also, the helical heater embracing the tubular holder is characterized by low rigidity to result in sagging and deformation of its coils resulting in possible contact of the coils with the holder or thermal screens and short-circuiting of the heater. This in turn leads to fewer engagements of the compensation cathode and reduced service life thereof. In addition, the working gas can contain negligible quantities of such admixtures as oxygen, water, or the like, tending to react at high working temperatures with the material of the thermal emitter and affecting the thermoemissive characteristics of the material. Extended operation for tens or hundreds of hours makes this disadvantageous effect even more prominent to reduce the service life of the compensation cathode.

Summary of the Invention

The present invention aims at providing a plasma compensation cathode which would be so constructed as to lock discharge zone in the passage of the thermal emitter, prevent chemical interaction of the thermal emitter with the material of the holder and with the thermal system maintaining automatically the preferred temperature of the thermal emitter at minimised cathodic potential drop, and also to increase the rigidity of the heater and facilitate additional cleaning of gas from impurities.

The aim of the invention is attained by that in a plasma compensation cathode comprising a casing accommodating coaxially with its outlet hole a hollow holder and thermal emitter having a central

passage communicating with the interior of the holder, a heater embracing the holder, heat screens positioned between the heater and walls of the casing, and a pipe for feeding gas to the interior of the holder secured in a support insulator, according to the invention, the central passage of the thermal emitter is blind at the side of admission of gas and is communicated with the interior of the holder by way of a through passage made in the wall of the thermal emitter so that its axis intersects the axis of the central passage, and longitudinal grooves provided at the side surface of the thermal emitter at the location of inlet holes of the through passage, whereas the interior of the holder communicates with the gas feeding pipe through a sealed cavity defined by clearances between the coaxial heat screens successively interconnected by spacer rings and secured at the gas feeding pipe, underlying the holder in this cavity is a getter positioned between mechanical filters, the space between the inner surface of the holder and side surface of the thermal emitter accommodating a layer of material chemically inert at high working temperatures to the materials of the holder and thermal emitter, whereas the heater has a support ring located at its midportion and secured in an insulation sleeve separating the heater from the heat screens.

The use in the proposed plasma compensation cathode of a thermal emitter with a special passage for feeding gas, a layer of chemically inert material, a system of coaxial heat screens, a support ring, an insulation sleeve, a getter, and mechanical filters makes it possible to substantially extend the service life and increase the total number of actuations of the cathode.

Brief Description of the Drawings

The invention will now be described in greater detail with reference to a specific embodiment thereof taken in conjunction with the accompanying drawings, in which:

Fig. 1 shows a general view of the proposed plasma compensation cathode; and

Fig. 2 is a section taken along line 11 in Fig. 1

Best Mode of Carrying out the Invention

A plasma compensation cathode comprises a casing 1 (Fig. 1) having an inlet hole 2. The casing accommodates coaxially a hollow holder 3 and a thermal emitter 4 with a central passage 5. The holder 3 is positioned inside casing 1 coaxially with the outlet hole 2 and embraced by a heater 6 fashioned as a spiral one end of which is secured to the casing and the other to the holder 3. The heater 6 is provided with a support ring 7 located

at its midportion and functioning as an additional support point.

The central passage 5 of thermal emitter 4 is blind at the side of admission of gas, and is communicated with the interior of the holder 3 by way of a central passage 8 (Fig. 2) made in the wall of the thermal emitter 4, the axis of this passage extending perpendicularly to the axis of the central passage 5, and longitudinal grooves 9 provided at the side surface of the thermal emitter 4 at location of the inlet holes of the through passage 8. Occupying the space between the inner surface of the holder 3 and side surface of the thermal emitter 4 is a layer 10 (Fig. 1) of material chemically inert at high temperatures to the materials of the holder 3 and thermal emitter 4. Positioned between the heater 6 and walls of casing 1 is a system of coaxial heat screens 11 connected successively through spacer rings 12 and secured at pipe 13 for feeding gas to define a sealed cavity 14 where through the interior of the holder 3 communicates with the gas feeding pipe 13. A space between the holder 3 and pipe 13 accommodates a getter 15 positioned between mechanical filters 16, whereas the pipe 13 is secured in a support insulator 17. The heater 6 is separated from the system of heat screens 11 by an insulation sleeve 18 in which the support ring 7 is secured.

In operation of the proposed plasma compensation cathode the gas flows along the pipe 13 through the getter 15 and mechanical filters 16 to the interior of the holder 3, and then through the grooves 9 and 8 to the central passage 5 of the thermal emitter 4. The heater 6 acts to heat the thermal emitter 4 to a temperature ensuring emission of electrons sufficient for sustaining a stable electric discharge between the inner surface of the thermal emitter 4 and anode (not shown) of a plasma source. After bringing the device to steady state operating conditions the heater 6 is deenergized and compensation cathode operates automatically, whereby the required temperature level of the thermal emitter 4 is ensured thanks to the energy resulting from the discharge.

When the central passage 5 at the side of admission of gas is blind, the electric discharge in passage 5 can be stabilized by changing the pressure of gas and dimensions of the passage 5. This prevents fixation of discharge at the walls of holder 3 resulting in fouling and clogging of passage 5 of the thermal emitter 4, which facilitates maintaining the initial thermal emission from the inner surface of the thermal emitter 4 and substantially increases the service life of the compensation cathode. Positioning between the inner surface of holder 3 and side surface of the thermal emitter 4 of layer 10 of material chemically inert to the material of holder and thermal emitter 4 obviates chemical interaction

and diffusion of materials thereby making impossible irreversible deformation of holder 3 and cracking of holder 3 and thermal emitter 4. The accompanying advantage is substantially increased number of actuations and extended service life of the cathode. 5

The system of coaxial heat screens 11 defining with gas feeding pipe 13 and holder 3 sealed cavity 14 makes it possible to substantially reduce the heat flow from holder 3 of the thermal emitter 4 to outer parts of the cathode structure and, as a consequence, to reduce the potential drop at the cathode to the level of gas ionization potential and substantially extend the service life of the compensation cathode. 10 15

Provision of the support ring 7 secured in the insulation sleeve 18 allows to increase rigidity of the spiral of heater 6, prevent short-circuiting of the spiral of heater 6 (viz., engagement of the spiral coils with holder 3 or screens 11) even at a substantial deformation of spiral coils due to multiple engagement thermocycles. This again enables to increase the number of actuations and extend the service life of the compensation cathode. 20

Provision of the proposed compensation cathode with getter 15 positioned between mechanical filters 16 immediately at the location where the gas is admitted to the interior of the holder 3 affords extra fine chemical cleaning of gas from admixtures of oxygen, water, and the like, and ensures more stable thermoemission characteristics of thermal emitter 4 resulting in an extended service life of the compensation cathode. 25 30

Industrial Applicability 35

The invention can be used for neutralizing ion beams in accelerators with closed electron drift and extended acceleration zone, in accelerators with anodic layer and narrow acceleration zone, in plasma-ion accelerators, and also for compensating space and surface discharges. 40

Claims 45

1. A plasma compensation cathode comprising a casing (1) accommodating coaxially with its outlet hole (2) a hollow holder (3) and thermal emitter (4) with a central passage (5) communicating with interior of the holder (3), heat screens (11) interposed between the heater (6) and walls of the casing (1), and a pipe (13) for feeding a gas to the interior of the holder (3) secured in a support insulator (17), CHARACTERIZED in that the central passage (5) of thermal emitter (4) is blind at the side of gas admission, and is communicated with the interior of the holder (3) by way of a through 50 55

passage (8) made in the wall of the thermal emitter (4) so that its axis intersects the axis of the central passage (5), and longitudinal grooves (9) made at the side surface of the thermal emitter (4) at the location of inlet holes of the through passage (8), whereas the interior of the holder (3) communicates with gas feeding pipe (13) through a sealed cavity (14) defined by clearances between the coaxial heat screens (11) successively connected by spacer rings (12) and secured at the gas feeding pipe (13), the cavity (14) accommodating a getter (15) positioned under the holder (3) between mechanical filters (16), a space between the inner surface of the holder (3) and side surface of the thermal emitter (4) accommodating a layer (10) of material chemically inert at high temperatures to the material of the holder (3) and thermal emitter (4), whereas the heater (6) is provided with a support ring (7) at its midportion and secured in an insulation sleeve (18) separating the heater (6) from the thermal screens (11).

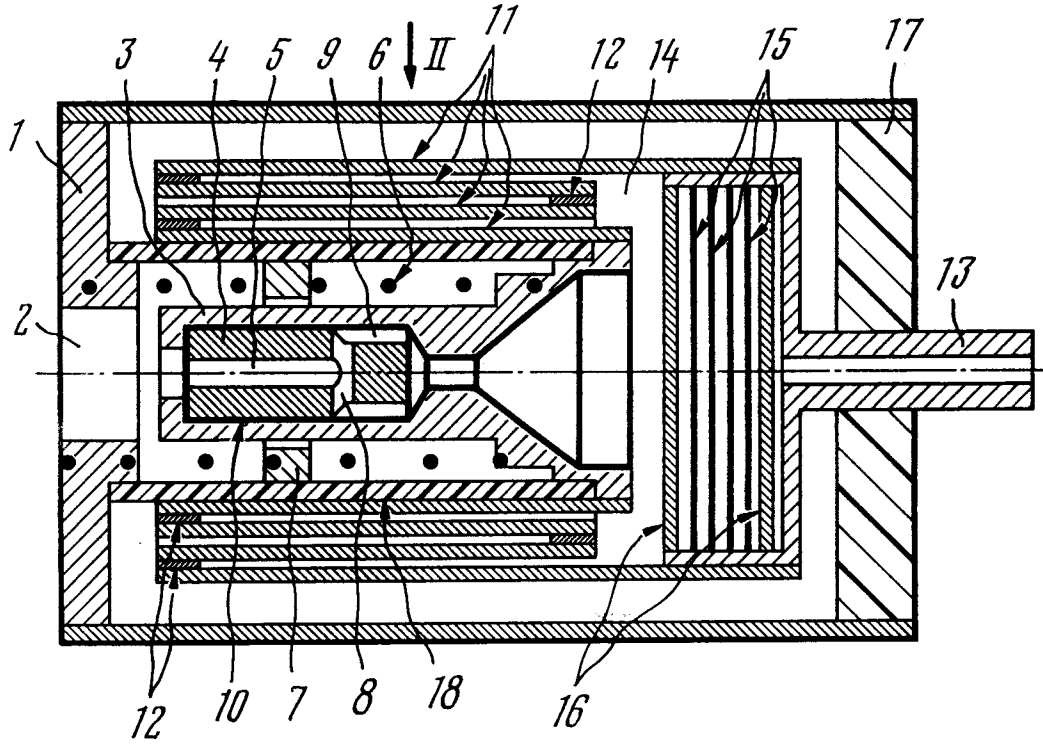

FIG. 1

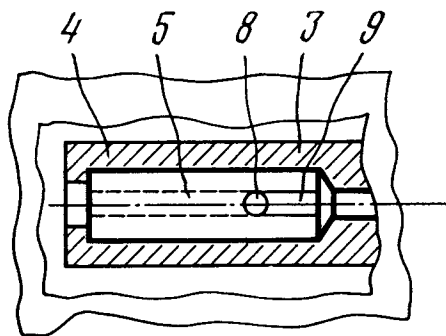

FIG. 2