

*E. Chipman,*

*Washing Machine,*

*N<sup>o</sup> 10,159.*

*Patented Oct. 6, 1863.*

*Fig. 1.*

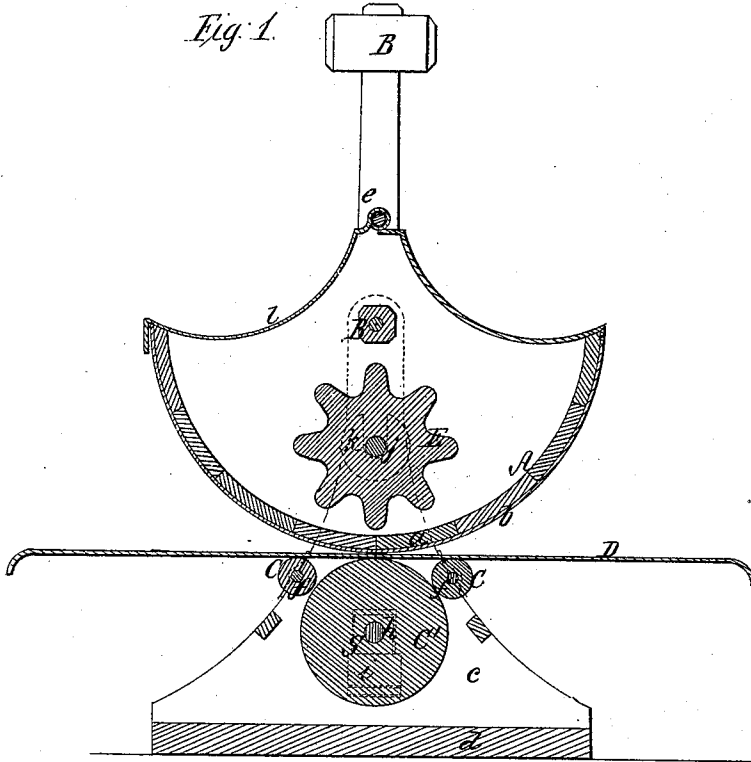

*Fig. 2.*

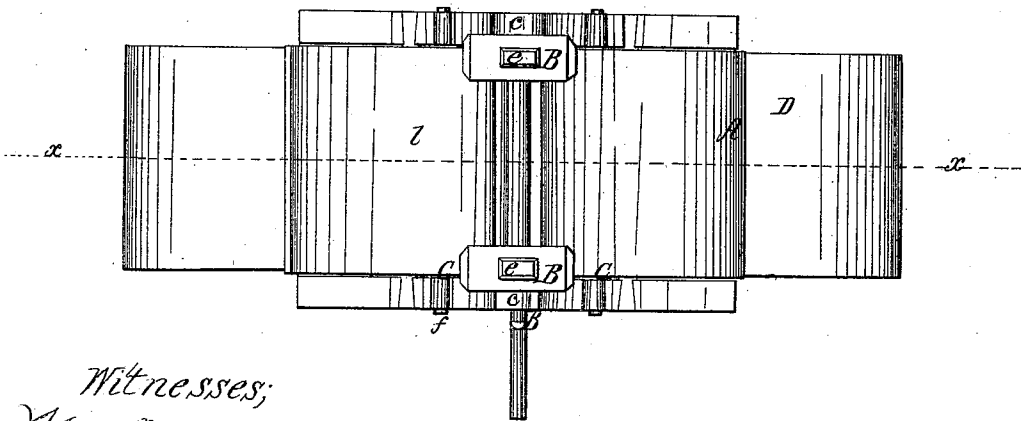

*Witnesses;*

*Wm. A. Douglas*

*Geo. Reed*

*Inventor;*

*Edgar Chipman*

# UNITED STATES PATENT OFFICE.

EDGAR CHIPMAN, OF NEW YORK, N. Y.

## IMPROVED WASHING, WRINGING, AND MANGLING MACHINE.

Specification forming part of Letters Patent No. 40,159, dated October 6, 1863.

*To all whom it may concern:*

Be it known that I, EDGAR CHIPMAN, of the city, county, and State of New York, have invented a new and useful Combination of a Clothes-Washing Machine, Wringer, and Mangle; and I do hereby declare that the following is a full, clear, and exact description of the same, reference being had to the accompanying drawings, making a part of this specification, in which—

Figure 1 is a side sectional view of my invention taken in the line *x x*, Fig. 2; Fig. 2, a plan or top view of the same.

Similar letters of reference indicate corresponding parts in the two figures.

This invention consists in the employment or use of an oscillating cylindrical or semi-cylindrical suds box provided with weights or counterpoises, and also provided with a fluted roller in combination with pressure-rollers and a sliding bed, all being arranged in such a manner as to form a new and useful combination of a washing-machine, wringer, and mangle, as hereinafter fully set forth.

To enable those skilled in the art to fully understand and construct my invention, I will proceed to describe it.

A represents a suds-box, which may be of cylindrical or semi-cylindrical form, the latter shape being preferable. This suds-box may be constructed of wood, and its bottom *a*, which is the curved part, may be covered with sheet metal *b*, zinc being a good material for the purpose. This suds-box A is suspended by a shaft, B, between uprights *c c*, which are attached to a suitable base-plate or bed, *d*, and the shaft B is allowed to turn freely in the uprights *c c*, the suds box being screwed to the shaft so that the former will turn with the latter.

At each side of the suds-box A there is an upright, *e*, on which a sliding or adjustable weight, B, is placed, and below the suds-box A, between the two uprights *c c*, there are placed three rollers, C C C'. The upper surfaces of the rollers C C are in one and the same horizontal plane. The central roller, C', is much larger in diameter than the other two, C C, and its upper edge a trifle above C C when not forced down by the suds-box A, and the journals of the shafts *f* of the latter are fitted in fixed bearings, while the

bearings *g* of the shaft *h* of the roller C' rest on india-rubber or other springs, *i*, as shown in dotted lines in Fig. 1, to admit of said roller yielding or giving to a certain extent.

D represents a bed, which is a plane surface, and may be constructed of wood or metal. This bed D is nearly or quite equal in width to the rollers C C C', and it may be of any suitable length, said bed when in use being placed between the bottom *a* of the suds-box A and the rollers C C C', as shown in Fig. 1. The rollers C C C' may be wood or metal.

Within the suds-box A there is placed a fluted roller, E, the journals of the shaft *j* of which are fitted in bearings *k* at the inner surfaces of the sides of the suds-box, and india-rubber or other springs may, if desired or necessary, rest on the journals of shaft *j*, to admit of a certain degree of vertical play or movement of said roller E. The suds-box A is provided with a door, *l*, at its top.

The operation is as follows: The box A is supplied with a requisite quantity of suds and the clothes to be washed placed therein.

The slide D being withdrawn from between the bottom of the suds-box and the rollers C C C', the weights or counterpoises B are then raised or lowered on the arms *e*, so as to balance or counterpoise the box A and its contents, and the shaft B is then rocked or turned a portion of a revolution, first in one direction and then in the other, a rocking or swinging motion being thereby given the suds-box A, and the clothes by their own gravity will as the box A is thus oscillated or rocked pass at the elevated side down the curved bottom *a*, between it and the fluted roller E. The clothes will in consequence be effectually cleansed, and by a very slight expenditure of power, owing to the balancing or counterpoising of the suds-box and its contents on the shaft B. After the clothes are washed the sliding bed D is inserted between the bottom *a* of the suds-box A and the rollers C C C', and the clothes will have the moisture expressed from them by being passed on the bed D underneath the curved bottom *a* of the suds box A. The rollers C C C', therefore, in connection with the suds-box A and sliding-bed D, are made to serve as a wringer and also as a mangle. The rollers

C C, it will be seen, serve as guides or bearings for the sliding bed D, the pressure being on the roller C'.

By this simple arrangement, therefore, a very useful and efficient combination of a washing machine, wringer, and mangle is obtained.

I would remark that when the device is used as a washing-machine the roller C' is let down so as to be free from the suds-box A by removing the springs from underneath the bearings of the journals of the shaft of said roller.

I do not claim separately the rocking or

oscillating suds-box, for that forms the subject of a distinct or separate application; but

I do claim as new and desire to secure by Letters Patent—

The combination of the counterpoised oscillating suds-box A with the roller C' and the rollers C C, or equivalent bearings, and sliding bed D, all arranged to operate in the manner substantially as and for the purpose herein set forth.

EDGAR CHIPMAN.

Witnesses:

THOS. S. J. DOUGLAS,  
J. W. COOMBS.