



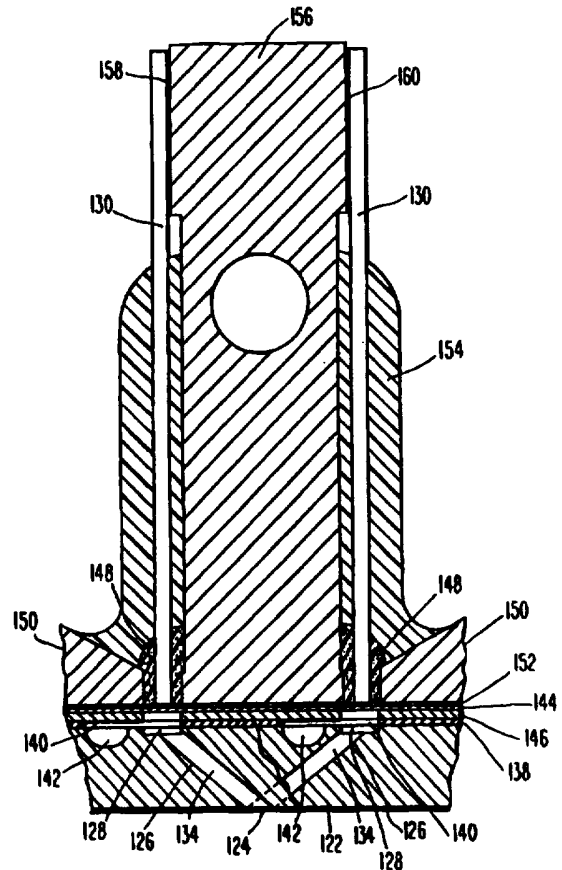
INTERNATIONAL APPLICATION PUBLISHED UNDER THE PATENT COOPERATION TREATY (PCT)

<p>(51) International Patent Classification <sup>6</sup> : <b>B41J 2/145, 2/14, 2/045</b></p>	<p><b>A1</b></p>	<p>(11) International Publication Number: <b>WO 96/09170</b>                   (43) International Publication Date: 28 March 1996 (28.03.96)</p>
<p>(21) International Application Number: PCT/US95/11973                  (22) International Filing Date: 20 September 1995 (20.09.95)                  (30) Priority Data:                  08/310,967 23 September 1994 (23.09.94) US                  (71) Applicant: DATAPRODUCTS CORPORATION [US/US];                  Suite 100, 1757 Tapo Canyon Road, Simi Valley, CA 93063 (US).                  (72) Inventors: ROGERS, Robert, L.; 29 Russett Road, Sandy Hook, CT 06482 (US). MIKALSEN, Arthur, R.D. 7, Knollcrest Road, Carmel, NY 10512-9801 (US). CARTIN, Jeffrey, G.; 122 Lone Oak Drive, New Milford, CT 06776 (US).                  (74) Agents: NORRIS, Norman, L. et al.; Woodcock Washburn Kurtz Mackiewicz &amp; Norris, 46th floor, One Liberty Place, Philadelphia, PA 19103 (US).</p>		<p>(81) Designated States: JP, European patent (AT, BE, CH, DE, DK, ES, FR, GB, GR, IE, IT, LU, MC, NL, PT, SE).                   Published                  With international search report.</p>

(54) Title: APPARATUS FOR PRINTING WITH INK JET CHAMBERS UTILIZING A PLURALITY OF ORIFICES

(57) Abstract

A dense array of ink jets is achieved by a fanning-in of chambers (126) to a linear array of orifices (124). The ends of the chambers (126) remote from the orifices have actuation locations (128) which are coupled to elongated transducers (130) having axes of elongation which are parallel to the axes of ejection of droplets from the orifices (124).



**FOR THE PURPOSES OF INFORMATION ONLY**

Codes used to identify States party to the PCT on the front pages of pamphlets publishing international applications under the PCT.

AT	Austria	GB	United Kingdom	MR	Mauritania
AU	Australia	GE	Georgia	MW	Malawi
BB	Barbados	GN	Guinea	NE	Niger
BE	Belgium	GR	Greece	NL	Netherlands
BF	Burkina Faso	HU	Hungary	NO	Norway
BG	Bulgaria	IE	Ireland	NZ	New Zealand
BJ	Benin	IT	Italy	PL	Poland
BR	Brazil	JP	Japan	PT	Portugal
BY	Belarus	KE	Kenya	RO	Romania
CA	Canada	KG	Kyrgystan	RU	Russian Federation
CF	Central African Republic	KP	Democratic People's Republic of Korea	SD	Sudan
CG	Congo	KR	Republic of Korea	SE	Sweden
CH	Switzerland	KZ	Kazakhstan	SI	Slovenia
CI	Côte d'Ivoire	LI	Liechtenstein	SK	Slovakia
CM	Cameroon	LK	Sri Lanka	SN	Senegal
CN	China	LU	Luxembourg	TD	Chad
CS	Czechoslovakia	LV	Latvia	TG	Togo
CZ	Czech Republic	MC	Monaco	TJ	Tajikistan
DE	Germany	MD	Republic of Moldova	TT	Trinidad and Tobago
DK	Denmark	MG	Madagascar	UA	Ukraine
ES	Spain	ML	Mali	US	United States of America
FI	Finland	MN	Mongolia	UZ	Uzbekistan
FR	France			VN	Viet Nam
GA	Gabon				

**APPARATUS FOR PRINTING WITH INK JET CHAMBERS UTILIZING  
A PLURALITY OF ORIFICES**

**Cross-References to Related Application**

This is a continuation-in-part of U.S. Patent Application Serial No.  
5 08/310,967, filed September 23, 1994.

**Background Of The Invention**

This invention relates to impulse or drop-on demand ink jet printers employing an array of ink jets which are capable of printing a substantial field of droplets on demand.

10 U.S. Patent 4,714,934 discloses an ink jet apparatus of the type shown in Figs. 1 through 3. The apparatus includes a print head 10 having a reservoir 12 and an imaging head of 14. The print head 10 is juxtaposed to a target 16 which is advanced by means of a transport system, including rollers 18 and 20, in an incremental fashion. As shown in Fig. 1, print head 10 includes an orifice plate 22, including orifices 24. In Fig.  
15 1, the orifices are shown further apart from each other than they are in practice for purposes of illustration.

The orifices 24 actually comprise a plurality of sets of orifices which are more fully described with reference to Figs. 2 and 3. The sets of orifices 24 are vertically displaced as a result of the inclination of the print head 10 with respect to the scanning  
20 direction depicted by arrow 26. The orifices 24 are arranged in groups of three (3) and inclined on the orifice plate 22 so as to be substantially vertical when the print head 10 is inclined with respect to the scanning direction 26 as shown in Fig. 1. The hash marks

- 2 -

28 and the orifice plate actually show this angle of inclination. The angle of the orifices 24 in each group with respect to the vertical as shown in Fig. 2 is chosen such that when the orifice plate 22 is inclined as shown in Fig. 1, sets of orifices 24 will be vertical. As scanning in the direction depicted by the arrow 26 proceeds, there is no overlap of any 5 droplets projected from the orifices so as to permit the apparatus as shown in Figs. 1 through 3 to create a vertical bar when the droplets are ejected sequentially in the proper timed relationship. Of course, the droplets can also produce an alphanumeric character by ejecting appropriate droplets on demand.

By changing the angle of inclination of the hash marks 28, it is possible to 10 change the angle of inclination of the print head 14. However, if the angle of inclination is increased beyond a certain limit, it becomes impossible to print a continuous bar since the orifices cannot be spaced sufficiently close together to provide full coverage of the field. In addition, the chambers associated with those orifices become starved for ink when operated at a sufficiently high frequency. Moreover, it has not been possible to 15 increase the number of chambers since cross-talk and limited real estate do not allow transducers to be coupled to the chambers.

As also shown in U.S. Patent No. 4,714,934, the individual ink jets include feet which are coupled to the ink jet chambers. These feet 46 are secured to a foot plate by a resilient rubber-like material, such as silicone. As a consequence, ink within the ink 20 jet chambers is exposed to a variety of materials including the foot, the silicone and the materials from which the remainder of the ink jet including the chamber and the orifices are made. This in turn produces compatibility problems which effectively limit the type of ink which may be employed in an ink jet apparatus.

### Summary Of The Invention

25 In accordance with one important aspect of the invention, an ink jet apparatus is provided whereby the spacing between a plurality of impulse ink jets in an array is substantially reduced thereby increasing the ability to print high quality images with an in-line array of orifices while minimizing cross-talk.

In accordance with this object of the invention, an ink jet apparatus 30 comprises an array of chambers, each of the chambers being terminated in at least one orifice such that the linear array of orifices is formed. Each of the chambers includes an

actuation location laterally displaced from the linear orifice array. A plurality of elongated transducers is juxtaposed to the actuation locations respectively such that the transducers have an axis of elongation extending substantially parallel with the ejection axis of each orifice and laterally displaced with respect to the linear orifice array.

5           In accordance with one important aspect of the invention, the actuation locations of adjacent chambers in the array of ink jet devices are mutually laterally displaced.

          In accordance with another important aspect of the invention, the axis of chambers are inclined at an acute angle with respect to the ejection axis of the chambers.

10           In accordance with another important aspect of the invention, the axes of the chambers are elbowed to include a first segment substantially parallel to the ejection axis and a second segment substantially perpendicular to the ejection axis.

          In accordance with still another important aspect of the invention, the axes of elongation of adjacent transducers are parallel but laterally displaced with respect to the  
15 axis of ejection from each of the orifices.

          In accordance with yet another important aspect of the invention, each of the chambers may include one or more orifices.

          It is another object of this invention to provide an impulse ink jet apparatus which has a high degree of compatibility with various inks. In accordance with this object  
20 of the invention, the ink jet apparatus includes an ink jet chamber, a transducer coupled to the chamber and a diaphragm separating the transducer from the chamber. In the preferred embodiment of the invention, the chamber and the diaphragm comprise a relatively inert material such as, for example, stainless steel.

          The transducer is bonded to the diaphragm by a suitable adhesive such as  
25 for example, a silicone adhesive. The transducer may also be encapsulated in a silicone material for acoustic damping.

          Preferably, the chamber is formed by sandwiching a plurality of stainless steel plates together including the diaphragm. The plates may comprise an orifice plate, chamber plate, a restrictor plate providing a restricted opening for ink to enter the  
30 chamber, the diaphragm and a spacer plate separating the diaphragm from the restrictor

plate such that movement of the diaphragm does not affect the size of the restricted opening to the ink jet chamber.

### **Detailed Description Of The Drawings**

Fig. 1 is a perspective view of the prior art ink jet printing apparatus  
5 previously discussed;

Fig. 2 is a plan view of an orifice plate of the prior art apparatus shown in  
Fig. 1;

Fig. 3 is a fragmentary view of the fragment 3 of the prior art apparatus  
shown in Fig. 2;

10 Fig. 4 is a plan view of the orifice plate of an ink jet apparatus embodying  
this invention;

Fig. 5 is an enlarged view of the fragment 5 shown in Fig. 4;

Fig. 6 is a sectional view of the ink jet apparatus of Fig. 4 taken along line  
6-6 of Fig. 5;

15 Fig. 6A is a partial view similar to Fig. 6 but depicting a second  
embodiment of the invention (in this embodiment, the elongated portions of chambers 126  
are implemented with right angles);

Fig. 7 is an enlarged fragmentary view of a fragment of Fig. 6;

20 Fig. 7A is a view similar to Fig. 7 but of the second embodiment depicted  
in Fig. 6A;

Fig. 8 is a plan view of an orifice plate representing another embodiment  
of the invention;

Fig. 9 is a fragmentary sectional view of the apparatus of Fig. 8 taken along  
line 9-9;

25 Fig. 10 is a plan view of the orifice plate of another ink jet apparatus  
representing yet another embodiment of the invention;

Fig. 11 is an enlarged fragmentary sectional view of the ink jet apparatus  
of Fig. 10;

30 Fig. 11A is a view similar to Fig. 11 but of yet another embodiment similar  
to that of Figs. 6A and 7A;

- 5 -

Fig. 12 is a plan view of another ink jet apparatus orifice plate representing another embodiment of the invention;

Fig. 13 is a sectional view of the ink jet apparatus of Fig. 12 taken along line 13-13.

## 5 Detailed Description of Preferred Embodiments

Referring to Figs. 4-6, one preferred embodiment of the invention comprises an orifice plate 122 having groups of three orifices 124 forming a linear array. In all, a total of 64 groups of orifices 124 are shown. Each linear array of orifices 124 is inclined such that the orifices 124 are vertically disposed with respect to the scanning  
10 direction when incorporated in a print head similar to that shown in Fig. 1. The angle of inclination of the orifice plate and thus the linear array of orifices 124 is 47.105 degrees so as to provide an overall field height  $h$  of 1.36 inches. As should be appreciated, the spacing between the groups of orifices 124 is necessarily small.

As shown in Figs 5-7, the orifices 124 terminate ink jet chambers 126 in  
15 drop-on-demand or impulse devices of the general type disclosed in U.S. Patent No. 4,646,106, incorporated herein by reference. Because the chambers 126 are necessarily closely spaced, it is not possible to confine the chambers to the area between adjacent groups of orifices 124. Rather, it is necessary to laterally extend the chambers 126 in opposite directions so as to provide actuation locations 128 which are laterally displaced  
20 from the linear array. As best shown in Fig. 5, the actuation locations 128 of adjacent chambers 126 are mutually laterally displaced. By virtue of this lateral displacement, there is sufficient room for elongated transducers 130, shown in Fig. 6, to eject droplets of ink on demand from the orifices 124 without cross-talk between chambers.

As best shown in Figs. 6, 6A, 7 and 7A, the chambers 126 or 126' may  
25 include either elongated sections 134 which are disposed at an acute angle with respect to the axis of ejection of droplets from orifice 124 as well as the axis of elongation of the transducers 130 or a elongated sections 134' which project along the axis of elongation of the transducers, then bend 90° towards the centerline or axis of ejection of droplets from orifice 124 and then bend 90° again traversing along the axis of ejection of droplets  
30 from orifice 124.

- 6 -

The inclined or elbowed, elongated portions 134 (or 134') of the chambers 126 (or 126') create a fanning-in effect so as to permit alignment of the groups of orifices 124 in a linear array while providing separation of the elongated transducers 130. Note that only a single orifice is shown in Figs. 7 and 7A since the sections represented by  
5 Figs. 6, 6A, 7 and 7A is through a single orifice. However, it will be appreciated that there are up to three orifices associated with each of the chambers 126 or 126' shown in Figs. 6, 6A, 7 and 7A. By utilizing this fanning-in effect, it is possible to achieve greater chamber density. For example, it is possible to achieve a chamber-to-chamber spacing of less than 0.0500 inches, preferably less than 0.0400 inches, and optimally less than  
10 0.0300 inches without cross-talk. The fan-in effect also allows chamber-to-chamber spacing of less than ten times the diameter or cross-sectional dimension of the chamber and preferably less than seven times this diameter.

As also shown in Fig. 6 and 6A, the ink jet apparatus includes a restrictor plate 138 having openings 140 which connect the actuation locations 128 with manifolds  
15 142. The manifolds 142 service an aligned row of actuation locations 128 with ink while an other manifold 142 services another aligned row of actuation locations 128 with ink. Additional manifolds 142 external to the elbowed elongated portions 134' of the chambers in Fig. 6A create additional fluidic compliance and permit secondary servicing of center manifold 142' and downstream activation locations 128.

20 In accordance with another important aspect of the invention, the ink which is ejected from the orifices 124 is separated from the transducer and its mounting materials by a relatively inert diaphragm 144 (see Fig. 6). Preferably, the diaphragm comprises stainless steel. Diaphragm 144 moves with the transducers 130 so as to eliminate ink compatibility problems. In order to assure that deflection of the diaphragm 144 by the  
25 transducers 130 does not affect the size of the restrictor opening 140, a spacer plate 146 is inserted between the diaphragm 144 and the restrictor plate 138.

In accordance with an important aspect of the invention, the diaphragm 144 (Fig. 6) is secured to the transducers 130 by an elastomeric adhesive (e.g., silicone) which extends upwardly into openings 148 in a body 150 and forms a layer 152 along the top  
30 of the diaphragm 144. As a consequence, retraction of the transducer 130 pulls the diaphragm 144 upwardly at the actuation locations 128 so as to permit additional ink from the manifolds 142 to enter the chambers 126. When the transducers 130 are deenergized

- 7 -

(i.e., electrically grounded), the diaphragm 144 will return to the quiescent, planar condition and droplets of ink 136 will be ejected from the orifices 124 as shown in Figs. 7 and 7A. In addition to the silicone adhesive, the transducer is secured to the body 150 and a central mounting 156 by an LRTV silicone 154. A conductive epoxy 158 (e.g., a silver epoxy) joins the transducers 130 to the mounting 156 at the extremity remote from the diaphragm 144.

Referring now to Figs. 8 and 9, another embodiment of the invention is shown wherein the angle of inclination  $\alpha$  of an orifice plate 222 is reduced to 29.236 degrees so as to provide an overall field height of 0.92 inches. The orifices 224 are arranged in groups of two. Thus the density of chambers from end to end of the orifice plate, 64 chambers in all, remains the same although the number of orifices is reduced since there are only two orifices 224 per chamber. As in the case of the embodiment of Figs. 4, 5, 6 and 7, the elongated portions of the chambers 226 are inclined so as to provide lateral displacement of the actuation locations of the chambers, which are not shown in Figs. 8 and 9. However, it will be appreciated that the chambers look substantially as shown in Figs. 6 and 7 such that the elongated portions of chambers 226 are inclined with respect to the axis of ejection for the droplets 236 as well as the axis of elongation for the elongated transducers.

Referring now to Figs. 10, 11 and 11A, an orifice plate 322 is shown having a total of 64 channels terminating in orifices 324. The orifices and channels or chambers are arrayed in linear fashion at an angle  $a$  of 14.135 degrees with respect to the scanning axis so as to provide an overall field dimension  $h$  equal to 0.46 inches. As shown in Fig. 11, the chambers 326 are once again inclined with respect to the axis of ejection of droplets 336. As shown in Fig. 6, the elongated transducers are also inclined with respect to the chambers 326. It will therefore be appreciated that, with reference to Figs. 10 and 11, there are a total of 64 channels shown with 64 orifices, i.e., one orifice per chamber. This also applies to embodiments of Figs. 6A and 11A in that there are a total of 64 channels shown with 64 orifices, i.e., one orifice per chamber.

Reference will now be made to Figs. 12 and 13 and the ink jet apparatus shown therein. Fig. 12 depicts an orifice plate 422 having groups of orifices 424, i.e., 3 orifices per channel or group. The chambers 426 extend laterally outwardly from the linear array of orifices 424 such that actuation locations 428 are laterally displaced from

- 8 -

the linear array. As shown in Fig. 13, the chambers 428 are not inclined with respect to the axis of ejection of droplets 436 but are formed with a right angle configuration. A first portion 434 extends laterally outwardly from the orifice to the actuation location 428. A single manifold 150 is shown which through the use of a restrictor plate, not shown  
5 serves all chambers extending laterally outwardly from the linear array.

With the various embodiments described, it will be appreciated that the center-to-center spacing between the chambers may be substantially reduced, thereby providing increased resolution. Heretofore, prior art of the types shown in Figs. 1-3 provide a center distance between chambers of approximately .0585 inches. Employing  
10 the principles of this invention, it is possible to reduce that center-to-center spacing of 64 chambers shown in Fig. 4 to .02952 inches.

In accordance with an important aspect of the invention, in particular the use of a stainless steel diaphragm, it is possible to provide for an ink jet device wherein substantially all materials exposed to the ink are relatively inert. In this regard, it is  
15 possible to provide a restrictor plate 138 and diaphragm 144 and a spacer plate 146 which are all stainless steel. It is also possible and preferred to provide a chamber plate in which the chambers 126 and the manifolds 142 are formed which comprises stainless steel or another relatively inert material. Other relatively inert materials include Kapton, PET or Teflon.

It will be appreciated that various configurations of chambers, orifices and chamber shapes may be utilized. For example, the number of chambers may exceed 64. For example, an array of 128 or 256 chambers or more may be utilized. It is also possible to terminate chambers in more than three orifices. For example, chambers  
20 terminating in four, five or six orifices or more are possible. Finally, it is possible to utilize various chamber shapes in addition to the inclined, elbowed or L-shaped chambers disclosed herein. It will further be appreciated that alignment of the array of orifices in linear fashion allows the use of various angles of inclination of the head thereby permitting a wide variety of applications of the ink jet apparatus.

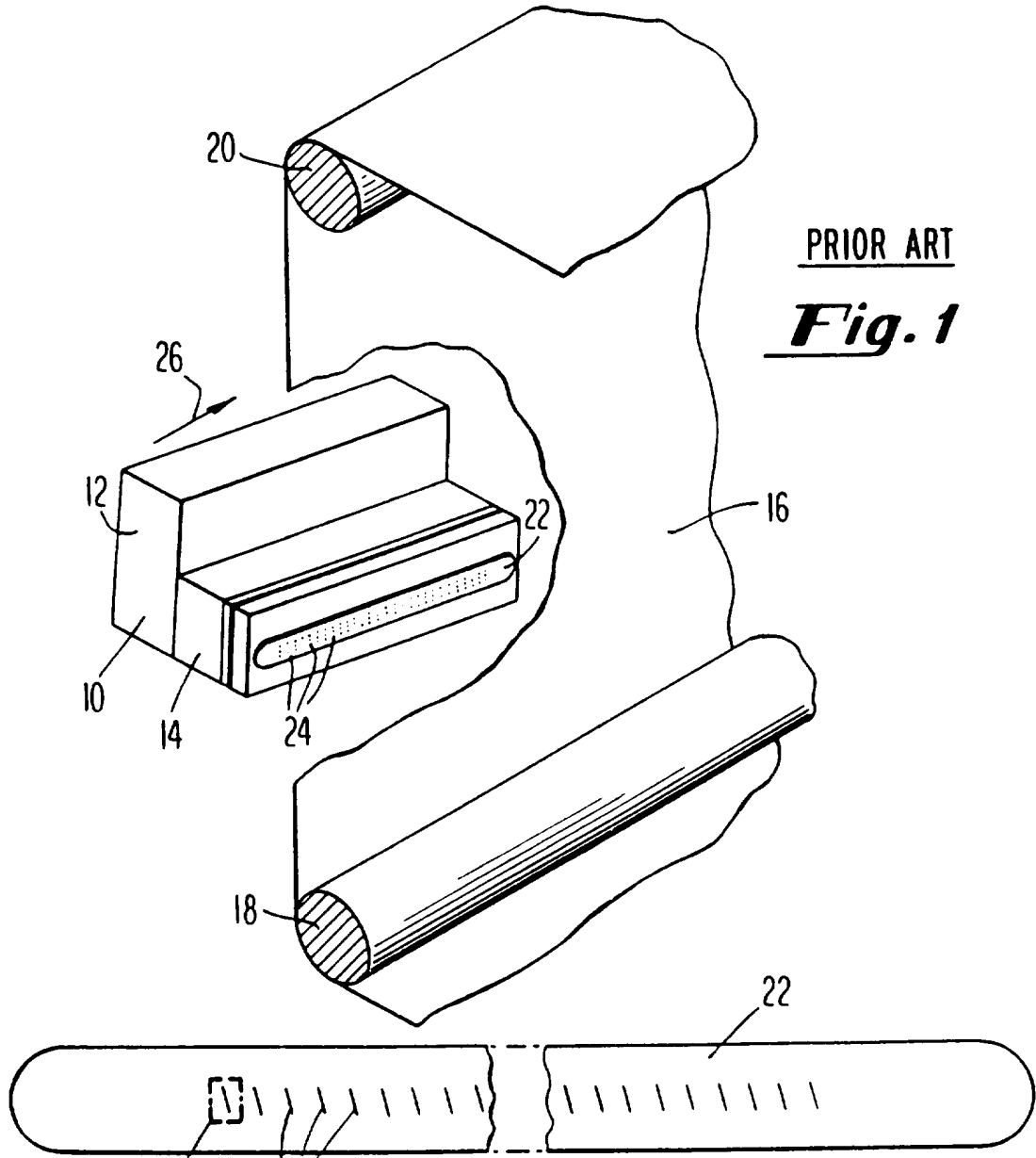
Although preferred embodiments of the invention have been shown and  
30 described, it will be appreciated that various modifications may be made which will fall within the true spirit and scope of the invention as set forth in the appended claims.

**In The Claims:**

1. An impulse ink jet apparatus comprising:  
a plurality of side-by-side chambers forming a linear array, each of  
said chambers being terminated in at least one orifice for ejecting droplets along an  
5 ejection axis, each of said chambers having an actuation location laterally displaced from  
said orifice; and  
a plurality of elongated transducers juxtaposed to said actuation  
locations respectively, said transducers having an axis of elongation extending substantially  
parallel with said ejection axis.
- 10 2. The impulse ink jet apparatus of claim 1 wherein said actuation  
locations of adjacent chambers are mutually laterally displaced.
3. The impulse ink jet apparatus of claim 1 wherein the axes of the  
chambers are inclined at an acute angle with respect to said ejection axis.
- 15 4. The ink jet apparatus of claim 1 wherein the axes of the chambers  
are elbowed and include a first segment substantially parallel to the ejection axis and a  
second segment substantially perpendicular to the ejection axis.
5. The ink jet apparatus of claim 1 wherein the axis of elongation of  
adjacent transducers are offset with respect to the axis of ejection.
- 20 6. The ink jet apparatus of claim 1 wherein each of said chambers  
includes a plurality of orifices.
7. The ink jet apparatus of claim 6 wherein each of said chambers  
comprises three orifices.
8. The ink jet apparatus of claim 6 wherein each of said chambers  
comprises two orifices.

- 10 -

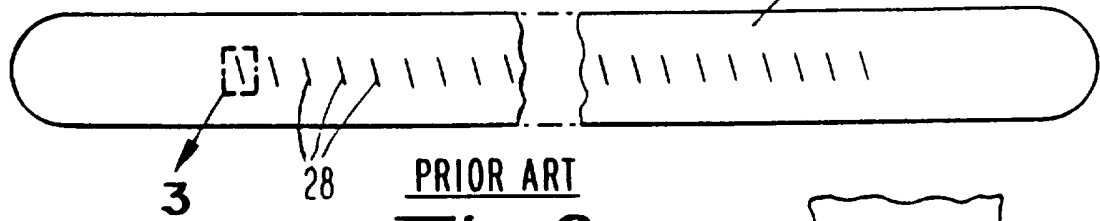
9. An impulse ink jet apparatus comprising:  
an ink jet chamber;  
a transducer for expanding and contracting the volume of ink in said chambers; and
- 5 a diaphragm coupling the transducer to the chamber and separating said transducer from ink within the chamber, said transducer being attached to said diaphragm such that the diaphragm is deformed so as to expand the chamber to an enlarged state when the transducer is energized and return the diaphragm to a planar state when the transducer is deenergized.
- 10 10. The ink jet apparatus of claim 9 wherein said transducer is elongated such that the axis of elongation intersects the diaphragm.
11. The ink jet apparatus of claim 10 further comprising adhesive means for attaching said transducer to said diaphragm.
- 15 12. The ink jet apparatus of claim 9 further comprising a chamber plate for forming said chamber, a restrictor plate providing a restricted opening for ink to enter the chambers, and a spacer plate separating the diaphragm from the restrictor plate such that movement of said diaphragm does not affect the size of the restricted opening allowing ink to enter the chamber.
- 20 13. The ink jet apparatus of claim 12 wherein said chamber plate, said restrictor plate, said diaphragm and said spacer plate comprise stainless steel.
14. The ink jet apparatus of claim 12 wherein said adhesive comprises a elastomeric adhesive.



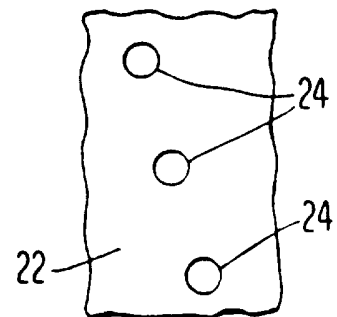
PRIOR ART

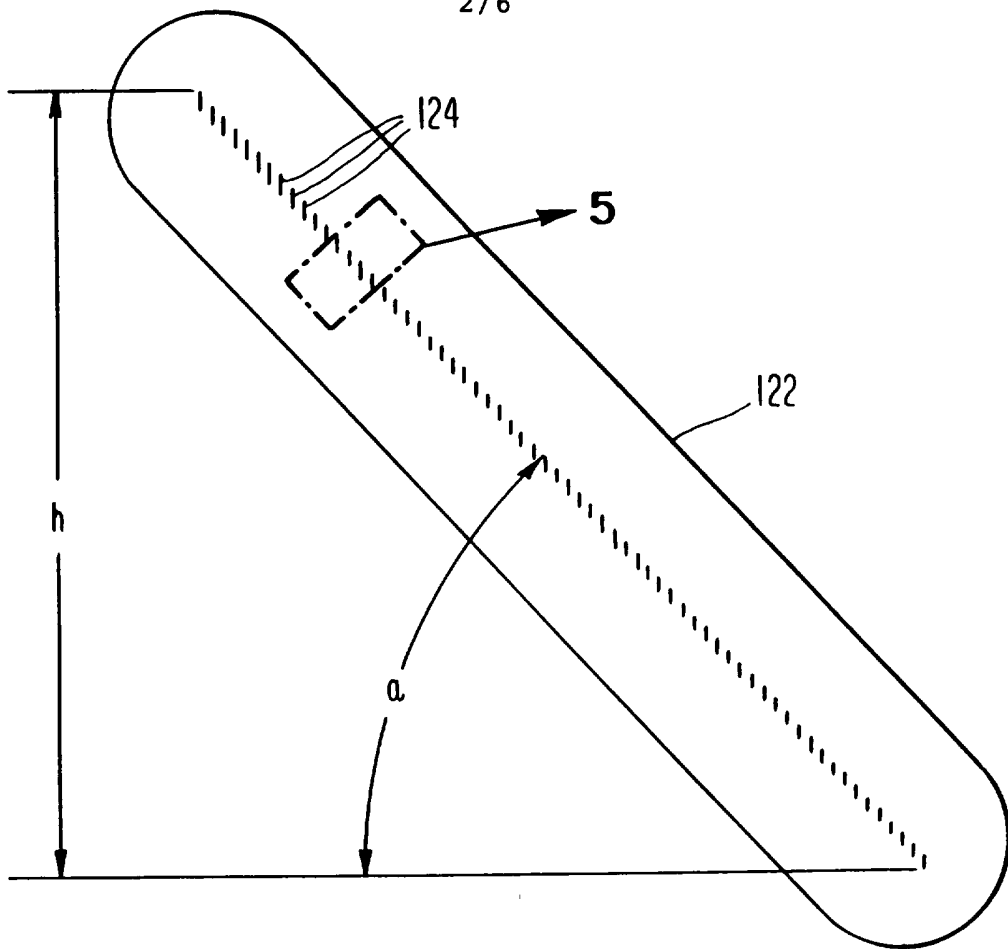
***Fig. 1***

PRIOR ART  
***Fig. 2***

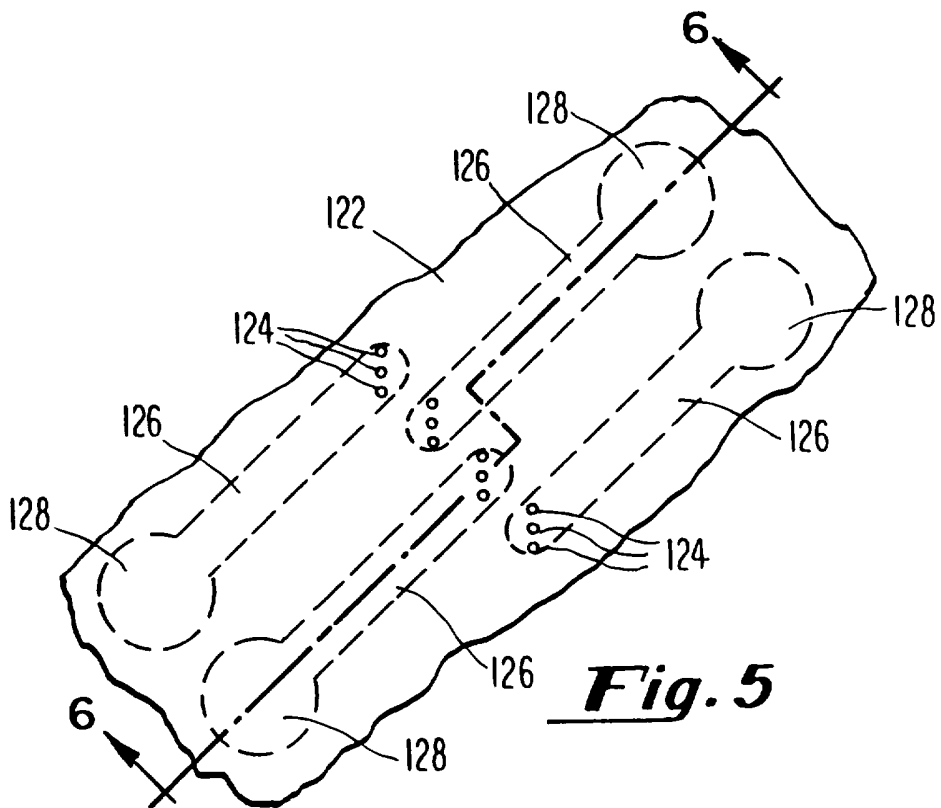


PRIOR ART  
***Fig. 3***

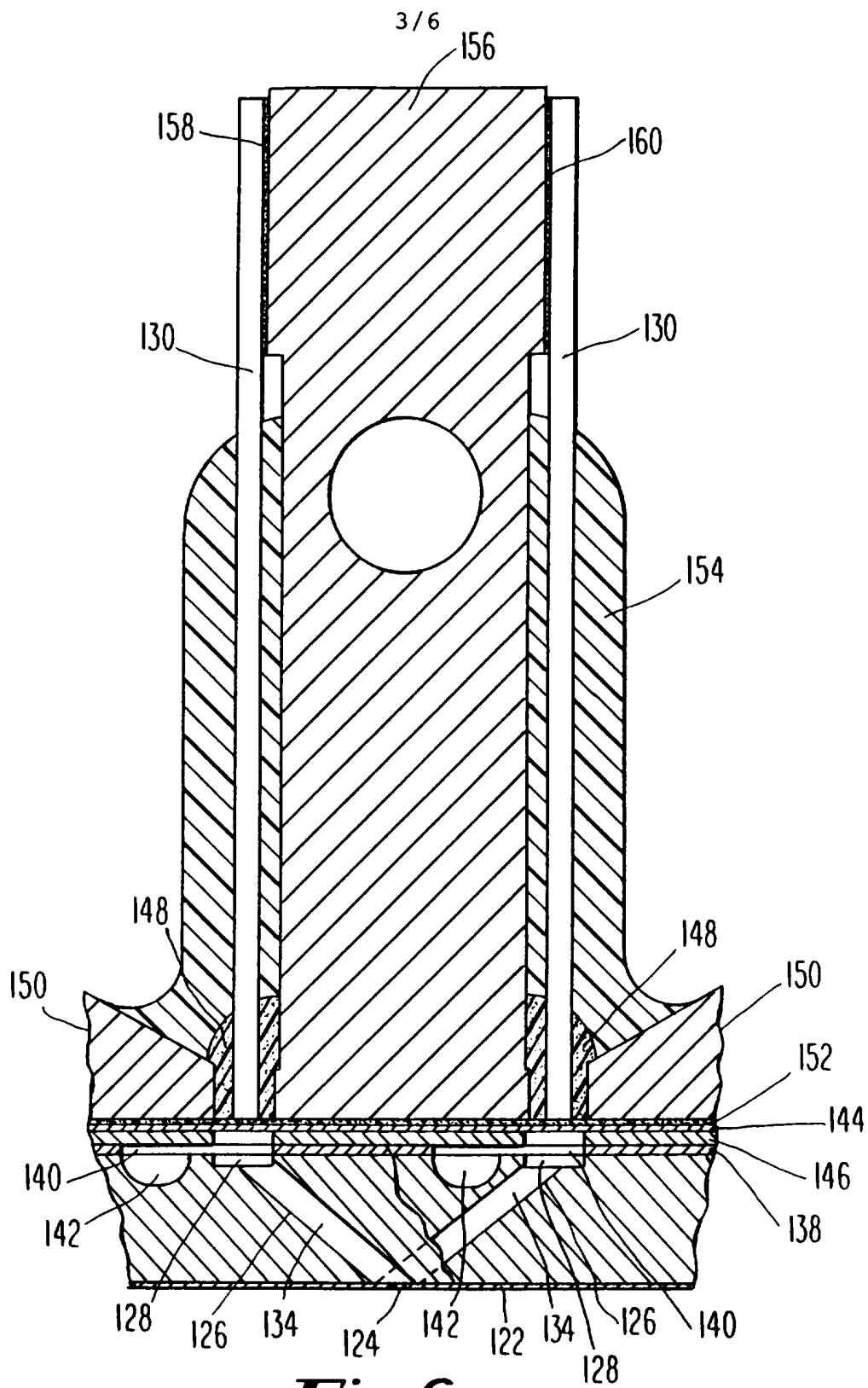




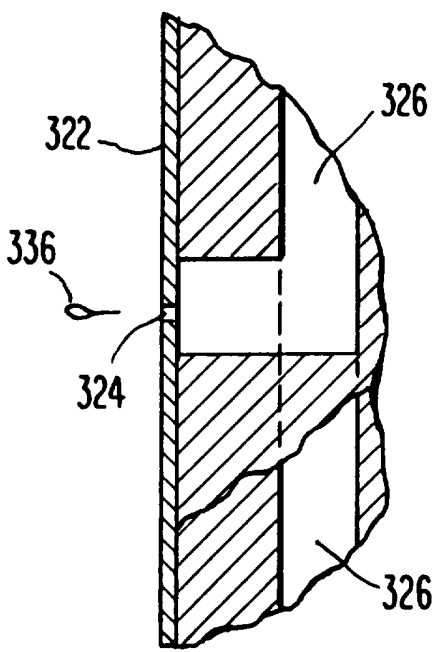
***Fig. 4***



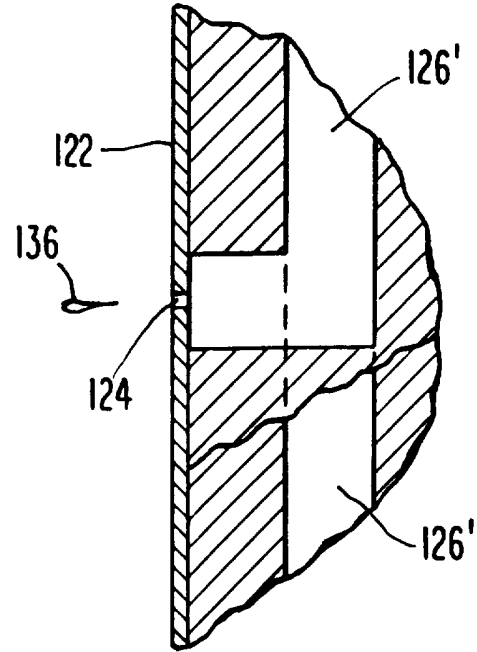
***Fig. 5***



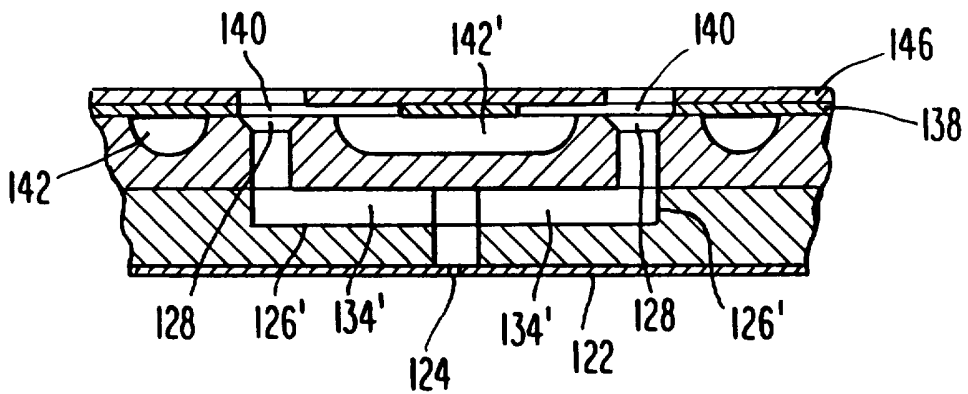
***Fig. 6***



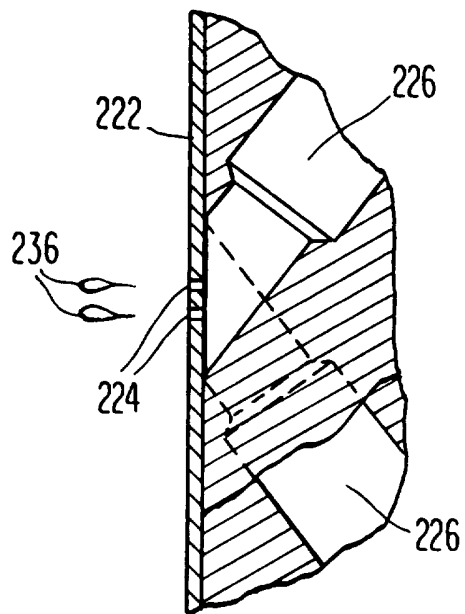
***Fig. 11A***



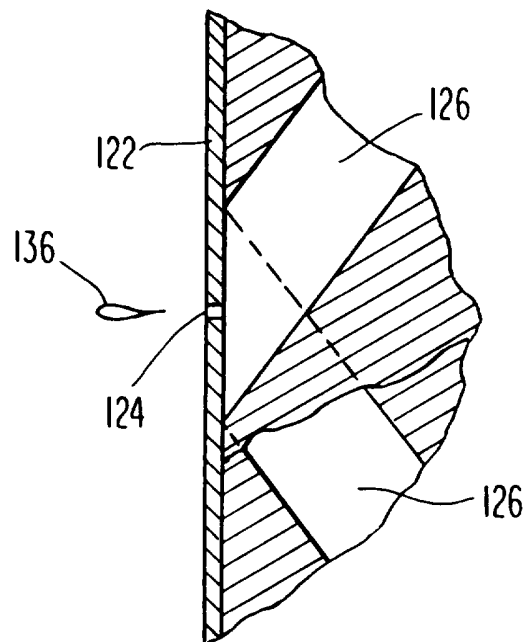
***Fig. 7A***



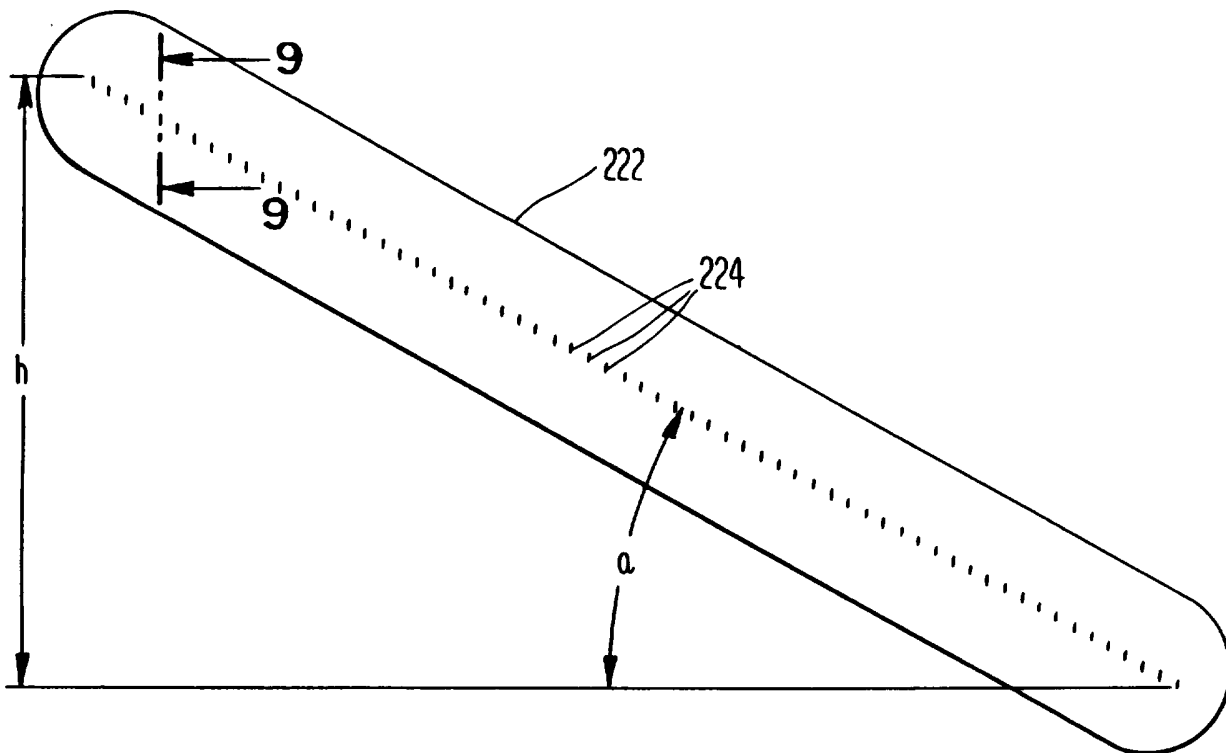
***Fig. 6A***



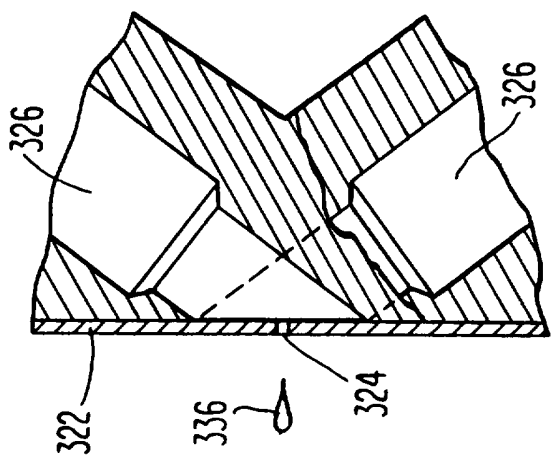
***Fig. 9***



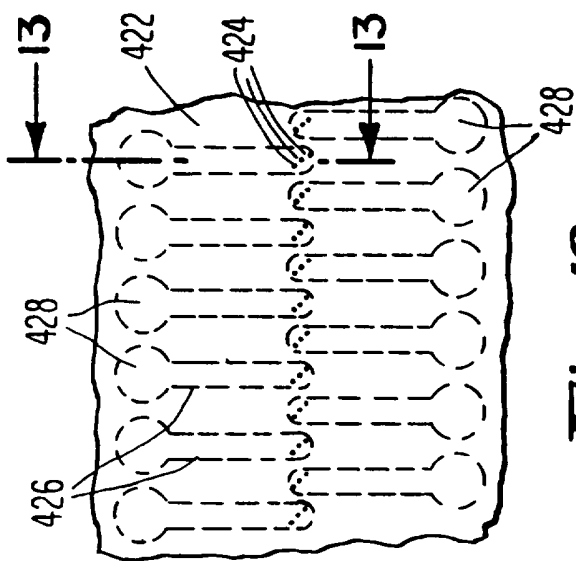
***Fig. 7***



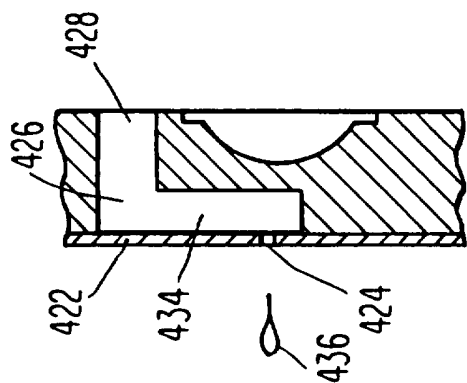
***Fig. 8***



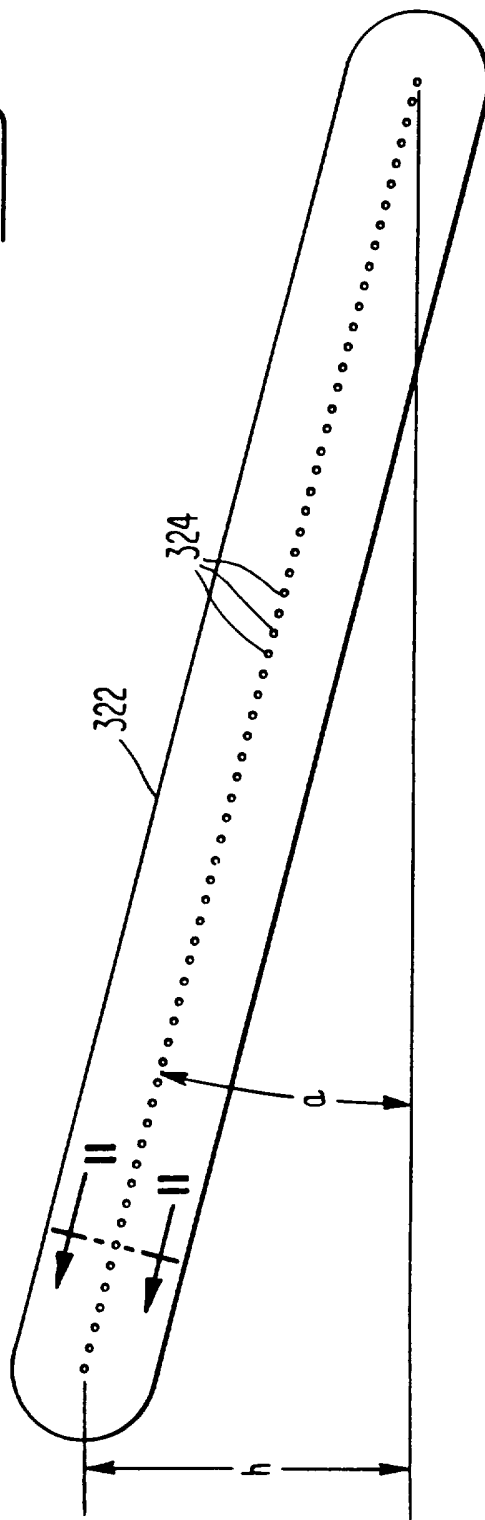
**Fig. 11**



**Fig. 12**



**Fig. 13**



**Fig. 10**

# INTERNATIONAL SEARCH REPORT

International application No.  
PCT/US95/11973

## A. CLASSIFICATION OF SUBJECT MATTER

IPC(6) : B41J 2/145, 2/14, 2/045  
 US CL : 347/40, 347/68, 347/48, 347/71, 347/72  
 According to International Patent Classification (IPC) or to both national classification and IPC

## B. FIELDS SEARCHED

Minimum documentation searched (classification system followed by classification symbols)

U.S. : 347/40, 347/68, 347/48, 347/71, 347/72

Documentation searched other than minimum documentation to the extent that such documents are included in the fields searched

Electronic data base consulted during the international search (name of data base and, where practicable, search terms used)

Please See Extra Sheet.

## C. DOCUMENTS CONSIDERED TO BE RELEVANT

Category*	Citation of document, with indication, where appropriate, of the relevant passages	Relevant to claim No.
X	-US, A, 4,901,093 (RUGGIERO ET AL) 13 February 1990 SEE ENTIRE DOCUMENT.	4-10, 13
Y	-US, A, 4,032,929 (FISCHBECK ET AL) 28 June 1977 see column 5, lines 19-47; Fig. 9 - column 1, lines 51-68 column 2, lines 1-24; Fig. 3.	1-3
Y	-US, A, 4,680,595 (CRUZ-URIBE ET AL) 14 July 1987 see column 5, lines 64-68 - column 6, lines 1-5; Fig.1.	11-12
A	-US, A, 4,714,934 (ROGERS) 22 December 1987. SEE ENTIRE DOCUMENT.	1-2

Further documents are listed in the continuation of Box C.       See patent family annex.

<p>* Special categories of cited documents:</p> <p>"A" document defining the general state of the art which is not considered to be of particular relevance</p> <p>"E" earlier document published on or after the international filing date</p> <p>"L" document which may throw doubts on priority claim(s) or which is cited to establish the publication date of another citation or other special reason (as specified)</p> <p>"O" document referring to an oral disclosure, use, exhibition or other means</p> <p>"P" document published prior to the international filing date but later than the priority date claimed</p>	<p>"T" later document published after the international filing date or priority date and not in conflict with the application but cited to understand the principle or theory underlying the invention</p> <p>"X" document of particular relevance; the claimed invention cannot be considered novel or cannot be considered to involve an inventive step when the document is taken alone</p> <p>"Y" document of particular relevance; the claimed invention cannot be considered to involve an inventive step when the document is combined with one or more other such documents, such combination being obvious to a person skilled in the art</p> <p>"&amp;" document member of the same patent family</p>
--	---

Date of the actual completion of the international search  
07 NOVEMBER 1995

Date of mailing of the international search report  
**11 JAN 1996**

Name and mailing address of the ISA/US  
Commissioner of Patents and Trademarks  
Box PCT  
Washington, D.C. 20231  
Facsimile No. (703) 305-3230

Authorized officer  
THINH NGUYEN *[Signature]*  
Telephone No. (703) 308-7487 *[Signature]*

**INTERNATIONAL SEARCH REPORT**

International application No.  
PCT/US95/11973

**B. FIELDS SEARCHED**

Electronic data bases consulted (Name of data base and where practicable terms used):

APS

search terms: (ink chamber or ink reser?) and transducer?  
                  orifice?(p)actuat?(p)diaphragm