

E. H. SCHWARTZ.
 CRUCIBLE FURNACE.
 APPLICATION FILED DEC. 14, 1910.

1,001,696.

Patented Aug. 29, 1911.

4 SHEETS—SHEET 1.

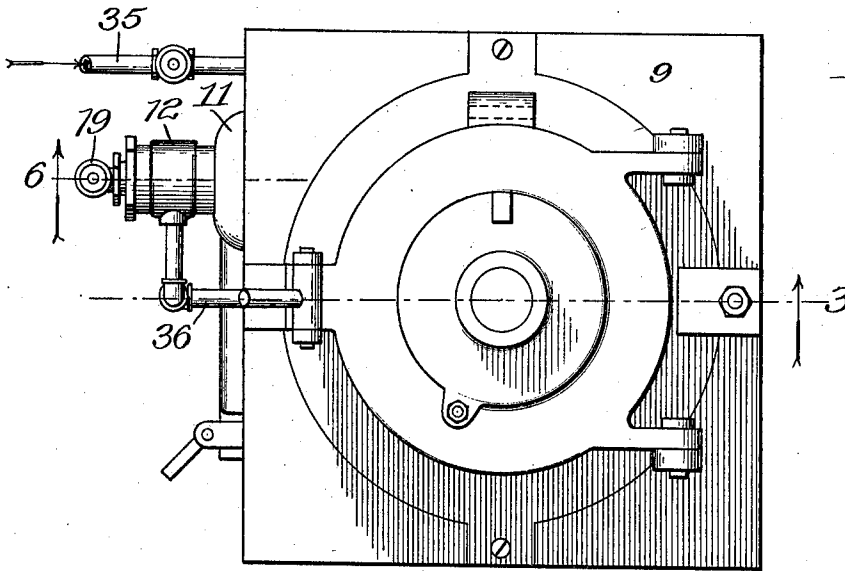
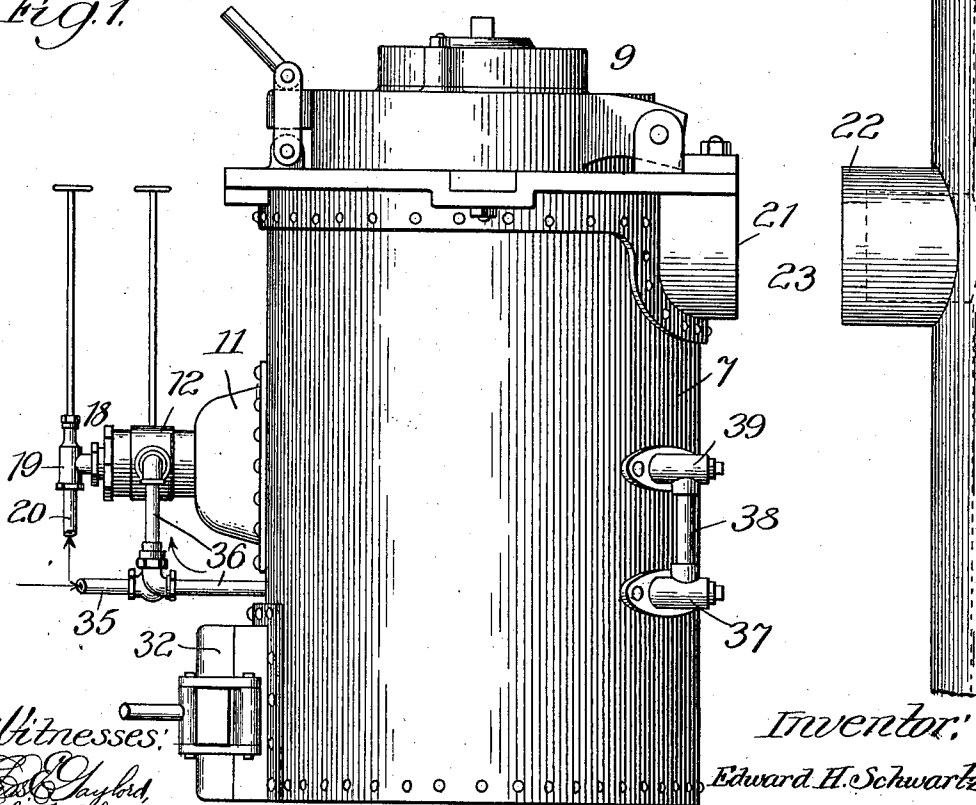

Fig. 2.

Fig. 1.



Witnesses:
E. J. Laybird,
J. F. Chase.

Inventor:
Edward H. Schwartz,

By Dyrenforth, Lee, Christian & Wilco,
Attorneys.

E. H. SCHWARTZ.
 CRUCIBLE FURNACE.
 APPLICATION FILED DEC. 14, 1910.

1,001,696.

Patented Aug. 29, 1911.

4 SHEETS—SHEET 2.

Fig. 3.

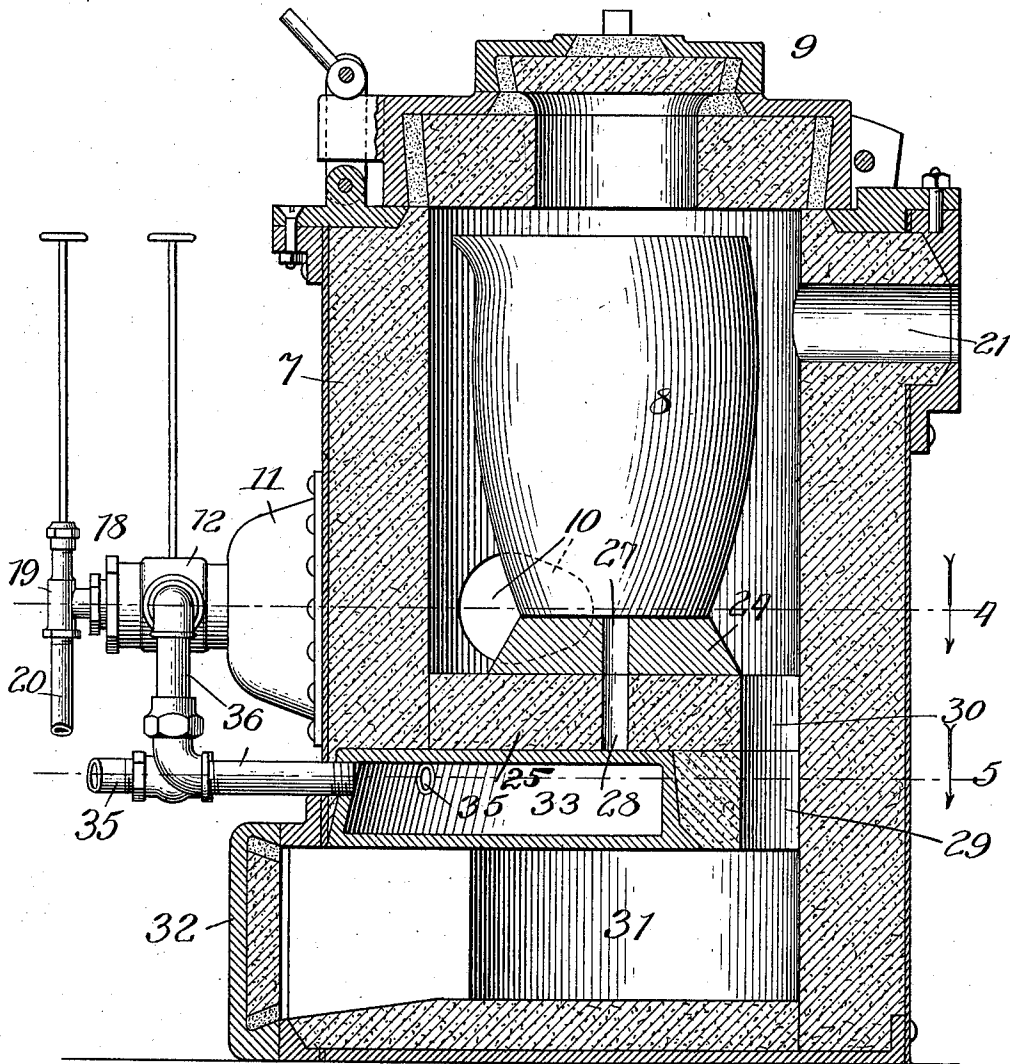

Witnesses:
E. H. Clayford,
A. F. Chase.

Inventor:
Edward H. Schwartz,
By Deane Smith, Le., Critton & Miles,
Attys.

E. H. SCHWARTZ.
 CRUCIBLE FURNACE.
 APPLICATION FILED DEC. 14, 1910.

1,001,696.

Patented Aug. 29, 1911.

4 SHEETS—SHEET 3.

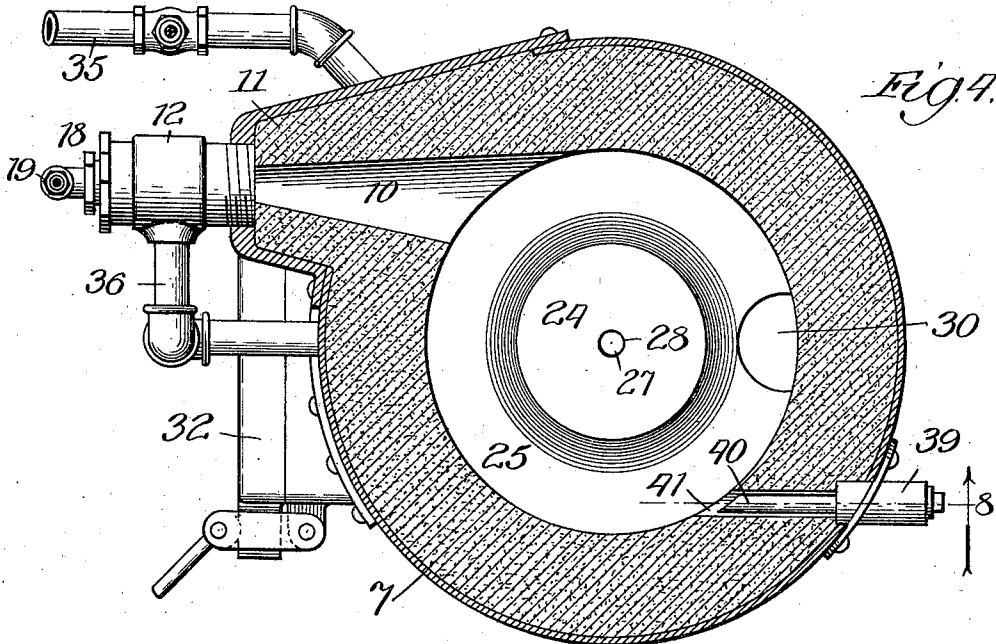
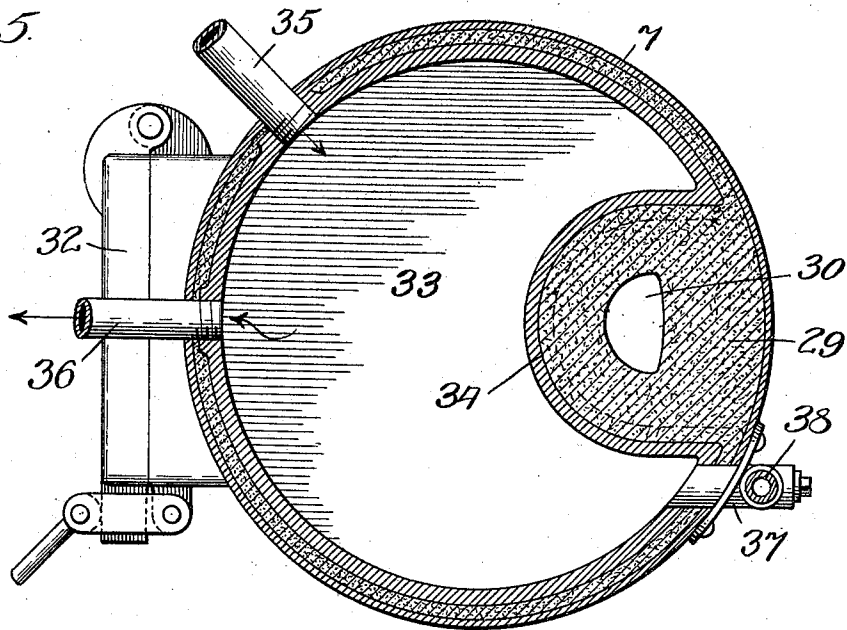

Fig. 5.



Witnesses:
W. C. Chylor,
G. F. Chase.

Inventor:
Edward H. Schwartz,
By J. J. Smith, Sec., Critton & Wells,
Attys.

E. H. SCHWARTZ.
 CRUCIBLE FURNACE.
 APPLICATION FILED DEC. 14, 1910.

1,001,696.

Patented Aug. 29, 1911.

4 SHEETS-SHEET 4.

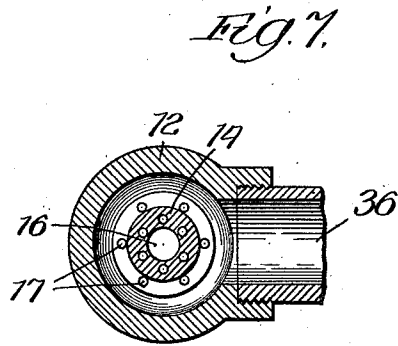
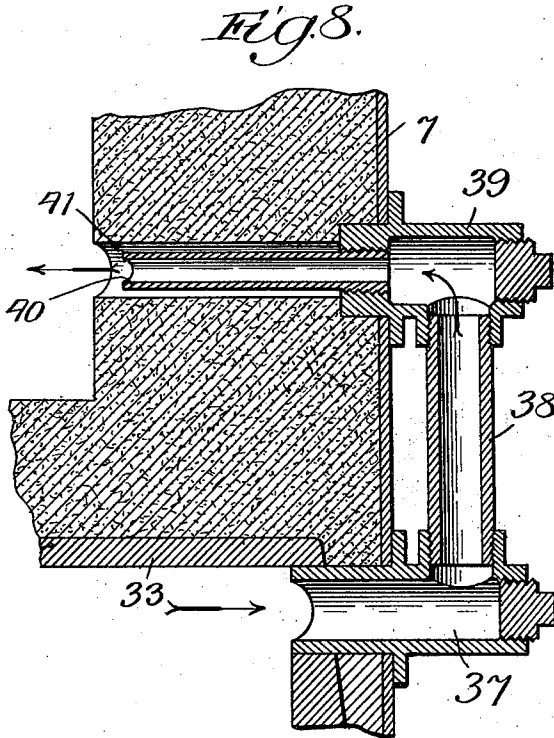
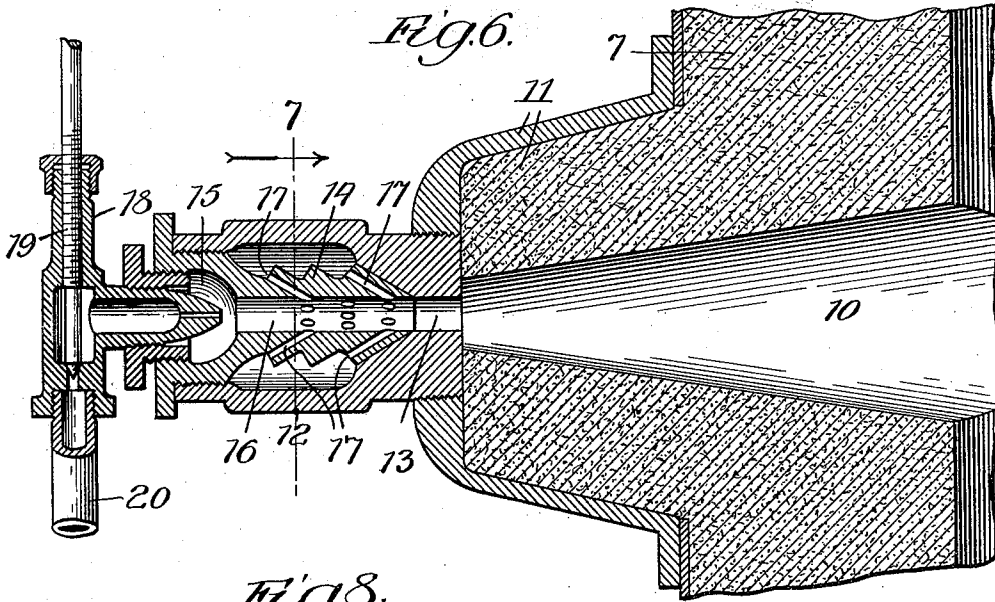

Witnesses:
E. C. Taylor,
G. F. Chass.

Inventor:
Edward H. Schwartz
By *Dunford, Lee, Christman & Miles,*
Attys.

UNITED STATES PATENT OFFICE.

EDWARD H. SCHWARTZ, OF CHICAGO, ILLINOIS, ASSIGNOR TO KROESCHELL BROTHERS COMPANY, OF CHICAGO, ILLINOIS, A CORPORATION OF ILLINOIS.

CRUCIBLE-FURNACE.

1,001,696.

Specification of Letters Patent. Patented Aug. 29, 1911.

Application filed December 14, 1910. Serial No. 597,281.

To all whom it may concern:

Be it known that I, EDWARD H. SCHWARTZ, a citizen of the United States, residing at Chicago, in the county of Cook and State of Illinois, have invented a new and useful Improvement in Crucible-Furnaces, of which the following is a specification.

My invention relates to an improvement in the class of crucible furnaces in which the fuel (gas or oil) and the air for promoting its combustion are introduced into the furnace-chamber at or near its base and the hot gases of combustion are given a gyratory motion in ascending to cause them to envelop the crucible supported in the chamber, for heating it to melt its contents.

My present invention, moreover, is primarily intended as an improvement in the construction of crucible-furnace shown and described in Letters Patent No. 911,271, granted to me February 2, 1909, for the purpose of enhancing its efficiency.

In the accompanying drawings, Figure 1 is a view in side elevation of my improved furnace shown as a stationary furnace; Fig. 2 is a top plan view of the same; Fig. 3 is a section on line 3, Fig. 2; Figs. 4 and 5 are sections respectively on lines 4 and 5, Fig. 3; Fig. 6 is an enlarged section on line 6, Fig. 2; Fig. 7 is a section on line 7, Fig. 6, and Fig. 8 is an enlarged section on line 8, Fig. 4.

The casing 7 is built, as usual, of refractory material sheathed with metal, and contains a seat for a crucible 8; and it is provided with a hinged brick-lined cover 9. The fuel-supply is introduced into the bottom part of the furnace-chamber at a port 10 extending tangential to the chamber through its wall from a protuberance 11 thereon, at which it communicates with a nozzle-device comprising a casing 12 forming a chamber having an outlet 13 registering centrally with the inlet-end of the port 10 and containing a nozzle 14 supported on the outer end of the casing 12, where it contains a chamber 15 from which extends the central bore 16 of the nozzle to register with the outlet 13 and into which a plurality of forwardly-converging ducts 17 lead from the chamber in the casing which surrounds the nozzle. The gas or oil supply-nozzle 18 is supported to project into the chamber 15 and discharge centrally into the adjacent end of the nozzle-bore 16 and it

extends from a needle-valve device 19 for controlling the supply to the furnace of the fuel through a pipe 20. Air is admitted through the furnace-wall into the crucible-chamber to discharge into the path therein of the gyrating gases and enhance their combustion.

The described construction of the nozzle-device is advantageous in causing the air, which is introduced into the chamber of the casing 12 for promoting combustion of the fuel, to be commingled therewith through the ducts 17 which, by their forward convergence to the passage 16, tend to insure a more thorough mixture of the air with the coursing fuel.

As thus far generally described, the structure is substantially the same as that set forth in the aforesaid patent.

The cover 9, according to the present improvement, is permanently closed to the discharge through it of the spent gases from the crucible-chamber and sealed against the admission of air through it into the chamber. I have found this to be of advantage, in excluding air from the furnace, because the air tends to oxidize the metal undergoing treatment in the crucible, with resultant waste, and in preventing the roaring noise of the furnace in operation, caused by that manner of the discharge. Instead, the discharge-outlet for the spent gases is provided as a duct 21 leading through the furnace-wall to aline with the stack-flue 22, but separated therefrom by a narrow air-space 23 (Fig. 1) of about, say, six inches in width. By this arrangement the spent gases discharge from the duct 21, across the space 23 into the stack noiselessly, without undue draft being exerted upon the crucible-chamber, which would tend to withdraw the gases before their desirably complete combustion has taken place, thereby retaining them longer in the chamber and therefore enhancing their combustion; and no air enters the crucible-chamber. By thus providing for the exclusion of air the loss of metal by oxidation is reduced to the minimum; and it furthermore enables the provision of carbonaceous material, as charcoal, over the top of the crucible for its reducing action on the metal being melted therein, but which would be consumed if air were introduced upon it through the furnace-cover.

The manner described of excluding air

from the crucible-chamber affords, in cooperative relation to other features of improvement later herein described, further advantages hereinafter explained.

5 The crucible is shown to be seated on a crucible-stool brick 24 which surmounts the floor-brick 25, the bricks being shown to contain vertical openings 27, 28, into which
10 to introduce a suitable implement for handling them in erecting the furnace. At the back of the crucible-chamber a brick 29 underlies the adjacent part of the floor-brick 25, and through the latter and the brick 29 is formed a slag-hole 30 leading to a slag-pit 31, below the crucible-chamber, in the
15 bottom of the furnace and of the full cross-sectional dimensions of the latter, which are sufficient for it to receive the entire molten charge of the crucible. The slag-pit is always in open communication through the
20 hole 30 with the crucible-chamber, but is sealed against the access of air into it, while the furnace is going, by a suitable door 32, so that in that construction no draft is exerted which would tend to pull down the
25 flame through the slag-hole into the pit; and under normal conditions the door need only be opened from time to time, while the furnace is out, to remove slag that may have
30 dropped from the lining and crucible. Should the crucible break, however, as sometimes happens, instead of its molten contents running into the crucible-chamber, whence its removal is attended with great difficulty
35 and loss, the metal will run through the slag-hole into the pit 31, where it may be held until such time as it may be conveniently removed upon opening the door and breaking up the metal. If the metal becomes
40 so far hardened by cooling or setting as to render too difficult its removal in that condition, the door 32 may be opened to admit air into the pit and exert draft through the slag-hole upon the crucible-chamber to
45 draw the flame into the slag-pit and cause it to melt the metal therein and thus facilitate its removal.

For the purpose of enhancing combustion of the fuel, the air supplied thereto for the
50 purpose should be preparatorily heated. For that purpose a metal air-chamber 33 is provided to extend over the pit 31, being of general circular shape to conform to the cross-section of the interior of the furnace,
55 with a recess 34 in it to admit the slag-hole brick 29; this chamber being surmounted by the floor-brick, and being, thus, enveloped in part of the structure that becomes sufficiently heated in the operation of the furnace to conduct enough heat to the chamber
60 33 for adequately heating the air that is introduced into it. This air enters through a supply-pipe 35 and discharges, in heated condition, partly through a pipe 36 leading
65 to the chamber 12 of the nozzle-device and

partly into the base of the crucible-chamber at a point therein diametrically opposite that with which the mouth of the fuel-port registers. For the last-named purpose a
70 pipe 37 leads from the air-chamber out through the furnace-wall, where it communicates with an upright branch 38 terminating at its upper end in a hollow head 39 supported on the furnace and having a
75 tube 40 extending horizontally from it into a duct 41 formed in the furnace-wall to open into the crucible-chamber at its base and supply in hot condition the air to be discharged therein into the path of the gyra-
80 torily-circulating gases.

What I claim as new and desire to secure by Letters Patent is—

1. In combination with a stack, a crucible-furnace having its contained crucible-chamber provided with a normally-sealed cover,
85 and a discharge-duct for the spent gases leading from said chamber through the furnace-wall to extend short of the stack-flue and forming between the flue and outer end of said duct a narrow open air-space, for the
90 purpose set forth.

2. In combination with a stack, a crucible-furnace having an inlet-port for burning gases leading tangentially into the base of
95 the crucible-chamber through its wall, and operating to circulate the hot gases gyra- torily about the crucible, an air-duct leading through said wall into said chamber to discharge into the path therein of said gases,
100 a normally-sealed cover surmounting the crucible-chamber, and a discharge-duct for the spent gases leading from said chamber through the furnace-wall to extend short of the stack-flue and forming between the
105 flue and outer end of said duct a narrow air-space, for the purpose set forth.

3. In combination with a stack, a crucible-furnace having a crucible-chamber provided with means for supplying gaseous fuel and air thereto and with a normally-sealed cover,
110 a discharge-duct for spent gases leading through the chamber-wall to extend short of the stack-flue and forming between the flue and outer end of said duct a narrow air-space a slag-pit below the crucible-chamber normally sealed against the ingress
115 of air and of a capacity adapting it to hold an entire crucible-charge, and a slag-hole through the bottom of said chamber affording open communication therewith of the slag-pit, for the purpose set forth.
120

4. In a crucible-furnace, the combination of an inlet-port for burning gases leading tangentially into the base of the crucible-chamber through its wall, a nozzle-device
125 communicating with said port for feeding thereto the fuel and mixing it with air, a slag-pit, an air-chamber between the crucible-chamber floor and slag-pit exposed to heat from adjacent parts of the furnace and
130

having an inlet-pipe, a discharge-pipe leading to said nozzle-device and a discharge-pipe leading out through the furnace-wall and having an upright branch terminating in a head with a branch leading from it through said wall to the crucible-chamber at a point therein away from said inlet-port, for the purpose set forth.

5. In a crucible-furnace, the combination of an inlet-port for burning gases leading tangentially into the base of the crucible-chamber through its wall, a nozzle-device communicating with said port for feeding thereto the fuel and mixing it with air, a slag-pit below the crucible-chamber, a slag-hole through the base of said chamber and

a slag-hole brick forming the lower section of said hole, an air-chamber below the crucible-chamber floor and provided with a recess to receive the slag-hole brick, an air-inlet pipe leading into the air-chamber, a discharge-pipe leading therefrom to said nozzle-device, and a discharge-pipe leading therefrom into the bottom of the crucible-chamber at a point therein opposite the mouth of said inlet-port, for the purpose set forth.

EDWARD H. SCHWARTZ.

In presence of—

A. U. THORIEN,
J. G. ANDERSON.

Copies of this patent may be obtained for five cents each, by addressing the "Commissioner of Patents, Washington, D. C."