

May 8, 1945.

F. G. MARSHALL

2,375,673

SPINNER

Filed July 8, 1941

3 Sheets-Sheet 1

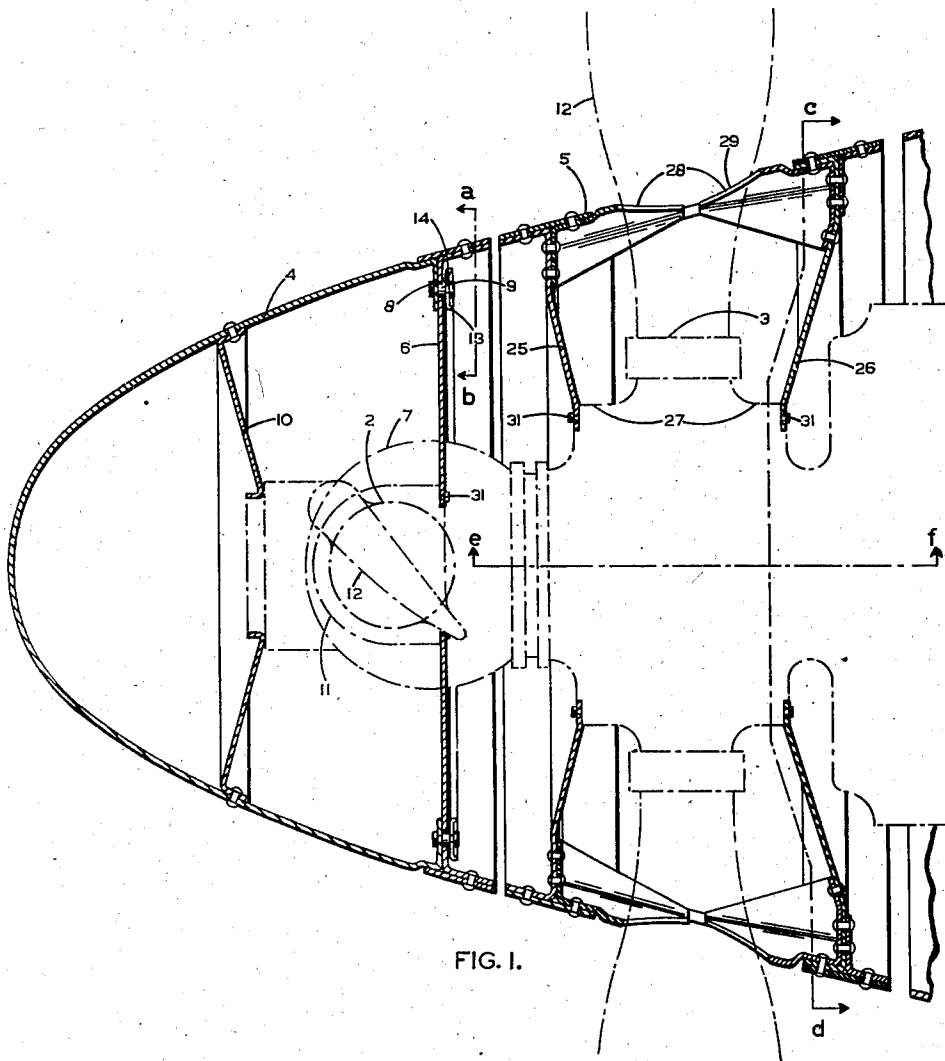

FIG. 1.

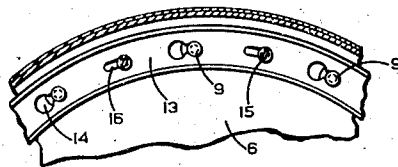

FIG. 2.

Inventor
Frederick L. Marshall
By Babcock & Babcock
Attorneys

May 8, 1945.

F. G. MARSHALL

2,375,673

SPINNER

Filed July 8, 1941

3 Sheets-Sheet 2

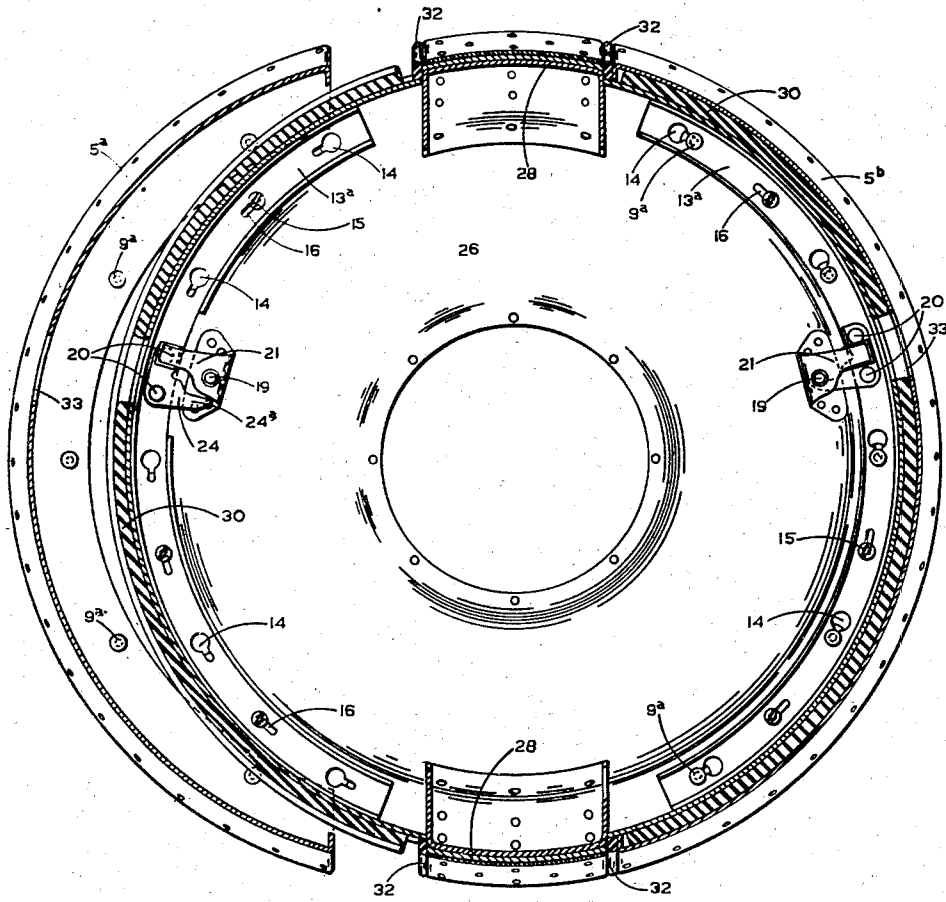

FIG. 3.

Inventor
Frederick J. Marshall
By Babcock & Babcock
Attorneys

May 8, 1945.

F. G. MARSHALL

2,375,673

SPINNER

Filed July 8, 1941

3 Sheets-Sheet 3

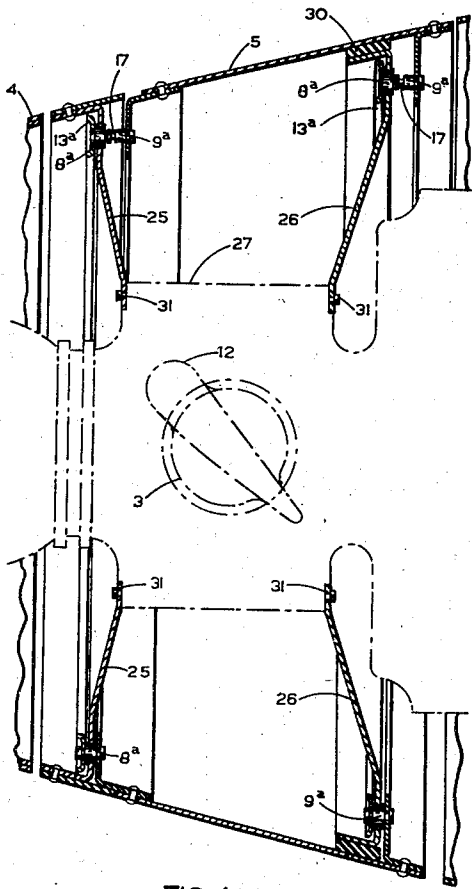

FIG. 4.

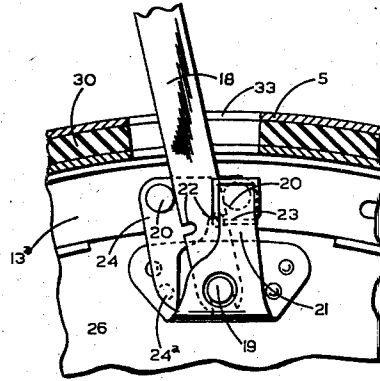

FIG. 5.

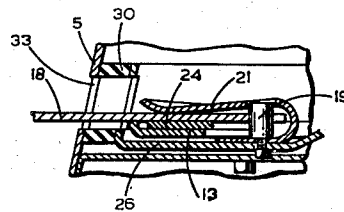

FIG. 6.

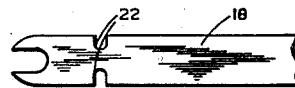

FIG. 7.

Inventor
Frederick L. Marshall
By Babcock & Babcock
Attorneys

UNITED STATES PATENT OFFICE

2,375,673

SPINNER

Frederick George Marshall, Leamington Spa,
England, assignor to Constant Speed Airscrews
Limited, Warwick, England

Application July 8, 1941, Serial No. 401,534
In Great Britain September 11, 1940

2 Claims. (Cl. 170—159)

This invention relates to a spinner for an air-screw or propeller of aircraft and its primary field of use will be as the spinner for the rear member of tandem airscrews or propellers, although it is not restricted to such use and may be used wherever its construction permits.

The primary objects of this invention are: to provide a spinner having its shell or periphery split longitudinally into a plurality of arcuate sections movable radially of the axis of the air-screw or propeller or laterally of the rotating propeller or airscrew shaft or hub; to provide cooperating plates or parts or members secured to the hub and flanges or parts or members connected respectively with the respective sections of the spinner shell in combination with means for interlocking these parts or members by a simple and quick manipulation whereby the spinner shell may be mounted on the hub and locked thereto to rotate therewith or may be released and removed in sections from said hub.

Since the primary field of use contemplated for the invention is as the rear spinner for a tandem airscrew usually of two oppositely rotating co-axial propellers, the invention is herein described and illustrated as so used or applied.

Spinners of the kind herein referred to embodying the present invention are characterized by the provision of attachment means and by a form of construction for the rear spinner whereby each of the two spinner shells can be assembled about and removed from the hubs of their respective airscrews without involving the removal of either of the airscrews from their shafts.

For the purposes of assembly and removal the rear spinner shell is made in two or more parts or sections provided with readily releasable means of attachment to one another and to supports carried by the hub or shaft part of the rear airscrew.

The two spinners may be adapted for attachment either to the front or to the rear end of their respective airscrew hubs, the attachment means in any case being preferably such that each spinner can be secured in position and released therefrom at a number of points by means of fastening devices arranged for simultaneous or individual operation.

The front spinner may be of the orthodox aerodynamical shape and the rear spinner formed as a continuation of said shape.

In the accompanying drawings,

Figure 1 is a longitudinal sectional view of spinners for contra-wise airscrews mounted ac-

ording to one way of carrying out the present invention.

Figure 2 is a detail view on the line *a—b* in Figure 1 of the locking ring for the front spinner.

Figure 3 is a cross-sectional view of the rear spinner taken on the line *c—d* of Figure 1, and showing one part or section thereof removed from its support.

Figure 4 is a view in axial plane section of the rear spinner taken on the line *e—f* of Figure 1, and showing one part or section thereof disengaged from its support.

Figures 5 and 6 are detail side and sectional views respectively of the device employed to prevent accidental displacement of the locking member.

Figure 7 illustrates a key for use in moving the locking member into and out of its operative position.

Referring to the drawings, 2 and 3 represent the two oppositely rotating airscrews which are co-axially arranged and have their respective shafts driven in any suitable manner from the engine. 4 and 5 are the two spinners which rotate in opposite directions and are attached to their respective airscrews.

The front spinner 4 may either be made in one piece by a spinning operation in the usual way, or may be of a built-up construction and in any case is of the orthodox aerodynamical shape substantially as shown.

The rear spinner is divided longitudinally into two parts or sections 5^a, 5^b and is shaped to form a continuation of that of the front spinner.

Each spinner or spinner part may be mounted and driven in the manner described in the specification of British Patent No. 451,553, or as described in the specification of British Patent No. 485,903, that is to say, each spinner or spinner part can either be driven from the rear of the hub of its respective airscrew or, as shown, from the front thereof, and in both cases can be supported by the usual front and rear diaphragms, or, by means of spoked members in the manner described in our co-pending British application No. 6,139 of 1940.

In the example shown in the drawings, the front spinner 4 is adapted for attachment to a back plate 6, at a number of points simultaneously. The said back plate 6 is secured to the rear of the hub 7 of the front airscrew and is formed with an annular series of equally spaced holes 8 and the inwardly flanged rear edge of the skirt of the spinner is provided with a series of pins 9 corresponding to number and spacing with the

holes 8 in the back plate. The front part of this spinner is supported by a front plate 10 riveted or otherwise permanently secured thereto and having a central aperture which is a sliding fit on the front end of the hub 2. The skirt of the spinner is suitably gapped at 11 to accommodate the roots of the propeller blades 12, those portions of the gaps behind the blades being closed by the usual filling pieces attached to the back plate. The spinner is pushed into position in an axial direction over the hub 2, the pins 9 thereon protruding through the holes 8 in the back plate and establishing a driving connection between the latter and the spinner. The pins may be locked in engagement with their holes in any suitable manner and the arrangement may be reversed if desired, that is to say, the pins may be carried by the back plate and the holes formed in the spinner or in a flange attached thereto. In either case the pins may be locked in engagement with their holes by means of a locking member consisting of a ring 13 formed with a series of key-hole slots 14, see Figure 2, corresponding in number and spacing with the pins 9. In the specific example shown the locking ring is carried by the back plate 6, being attached thereto by means of a series of screws 15 passing through parallel slots 16 in the locking ring so as to allow for a limited angular movement of the said ring relatively to the back plate. The protruding ends of the pins 9 are each formed with an annular groove 17 and the arrangement is such that when the spinner has been pushed into position on the hub with the pins protruding through the holes 8 in the back plate, the spinner can be instantly locked to the latter by rotating the locking ring 13 in a direction to bring the edges of the narrow portions of the key-hole slots 14 into engagement with the grooves 17 in the protruding ends of the pins. Conversely, a movement of rotation of the locking ring in the reverse direction will bring the large ends of the keyhole slots into register with the pins thereby enabling the spinner to be instantly detached. The locking ring may be rotated into and out of its operative or locking position in any suitable manner. For example, the ring may be provided with a finger piece or, as shown, in connection with the rear spinner, may be operated by means of a key 18 having a forked end. For this purpose a pivot pin 19 is provided on the back plate to receive the forked end of the key which when inserted engages between a pair of stops 20 on the locking ring so that by moving the key about its pivot in one direction or the other the ring is rotated into or out of its operative position.

In order to provide against accidental displacement of the locking ring from its operative or locking position as the result of vibration or other causes, a detent, such as a blade spring 21 carried by the back plate is arranged to engage between the said stops 20 when the locking ring is in its operative position. When the key is inserted through a slot 33 in the wall of the spinner the blade spring is lifted thereby out of engagement with the stops thus leaving the ring free to be moved into the inoperative position.

The key may also function as a safety device by means of an arrangement whereby the key can be inserted and withdrawn only when the locking ring is in its operative position. For this purpose the forked end of the key is formed with a notch 22 adapted when the locking ring has been moved thereby into the inoperative position, as seen in Figure 5, to engage an upturned flange

23 on a plate 24 attached to the ring. When the locking ring is turned by the key into its operative position the notch is clear of the flange and the key can be withdrawn. The said plate can, if desired, be formed with a limiting stop 24^a to engage the pivot pin when the locking ring is in its operative position.

The rear spinner 5 which rotates with the rear airscrew 3 and in a contrary direction to the front spinner is shown as divided longitudinally into two parts 5^a, 5^b so that it can be readily removed and replaced independently of the front spinner and without dismantling the airscrews. The said rear spinner parts are detachably mounted on and between front and back plates 25, 26 attached to the hub or shaft of the rear airscrew and the means of attachment may, as shown, be similar to those above suggested for the front spinner, that is to say, by means of pins 9^a carried by flanges secured to the front and rear ends of the spinner part engaging holes 8^a in the front and back plates. The locking means may also be similar except that in this case each part of the divided rear spinner will have its own locking member 13^a. As shown, the two parts of this spinner are driven from both ends of the rear hub 27 but, if desired, they can be driven from one end only of the hub in which case the other ends of the two parts can have a sliding engagement with their supporting plate. In the arrangement shown the two parts of the spinner are detached from their supports by first moving the locking member 13^a in each case into the inoperative position to release the pins 9^a from their holes 8^a. Each spinner part is then moved axially to an extent sufficient for the pins to clear the holes, as shown in the upper part of Figure 4, after which the spinner parts can be removed in a lateral direction, as represented at the left hand side of Figure 3.

In order to relieve the improved spinners of radial, torsional and other stresses and to damp out vibration rubber strips 30 or like cushioning means may be arranged between the spinner shells and their supports as shown, or the relief of such stresses and the damping out of vibration may be accomplished by any one of a number of suitable known ways and means.

Rubber strips 32 or other cushioning means may also be inserted between the flanged edges of the filling pieces 28 and the adjacent flanged edges of the gaps 11 or 29 in the spinner or spinner parts.

I claim:

1. A spinner for a rotating airscrew having a hub, said spinner comprising a shell composed of a plurality of separately detachable independent longitudinally extending sections adapted for assembly radially about said hub, and means for connecting said sections in assembled relation independently of each other, said means including radially extending elements carried by and rotatable with the hub for supporting said shell sections thereon, and separate independent radially inwardly extending cooperating elements connected with each shell section and means for detachably and drivably connecting said elements carried by the hub with said elements connected with the shell sections.

2. A spinner for a rotating airscrew having a hub, said spinner comprising a shell composed of a plurality of separately detachable independent longitudinally extending sections, and means for connecting said sections in assembled relation independently of each other, said means including

separate independent radially extending cooperating elements on each shell section and said hub, one set of said elements being formed with a plurality of peripherally arranged holes having axes extending parallel to the axis of said hub, in combination with fastening means for detachably and drivably connecting both sets of said elements, said fastening means comprising a plu-

5 rality of pins carried by the other set of said elements and corresponding in number to the number of said holes and extending thereinto in the driving relation of said elements, and a locking means for releasably securing said pins in such position.

FREDERICK GEORGE MARSHALL.