



(51) International Patent Classification:

B65G 45/22 (2006.01) *B65G 45/26* (2006.01)
B60S 3/04 (2006.01) *B65G 49/02* (2006.01)
B65G 21/00 (2006.01)

(21) International Application Number:

PCT/CA2018/051594

(22) International Filing Date:

13 December 2018 (13.12.2018)

(25) Filing Language:

English

(26) Publication Language:

English

(30) Priority Data:

62/598,641 14 December 2017 (14.12.2017) US

(71) Applicant: **STEPHENSON TECHNOLOGIES INC.**

[CA/CA]; 41 Saunders Road, Barrie, Ontario L4N 9A7 (CA).

(72) Inventors: **STEPHENSON, Robert Roy**; 19 Regalia

Way, Barrie, Ontario L4M 7H7 (CA). **BOELRYK, Bartholomew John**; 28 Ottawa Ave., Barrie, Ontario L4M 2W7 (CA).

(74) Agent: **MILLMAN IP INC.**; 401 Bay Street, Suite 2108,

Box 60, Toronto, Ontario M5H 2Y4 (CA).

(81) Designated States (*unless otherwise indicated, for every*

kind of national protection available): AE, AG, AL, AM, AO, AT, AU, AZ, BA, BB, BG, BH, BN, BR, BW, BY, BZ, CA, CH, CL, CN, CO, CR, CU, CZ, DE, DJ, DK, DM, DO, DZ, EC, EE, EG, ES, FI, GB, GD, GE, GH, GM, GT, HN, HR, HU, ID, IL, IN, IR, IS, JO, JP, KE, KG, KH, KN, KP, KR, KW, KZ, LA, LC, LK, LR, LS, LU, LY, MA, MD, ME,

(54) Title: BELT CONTACT SURFACE FOR CONVEYOR SYSTEM

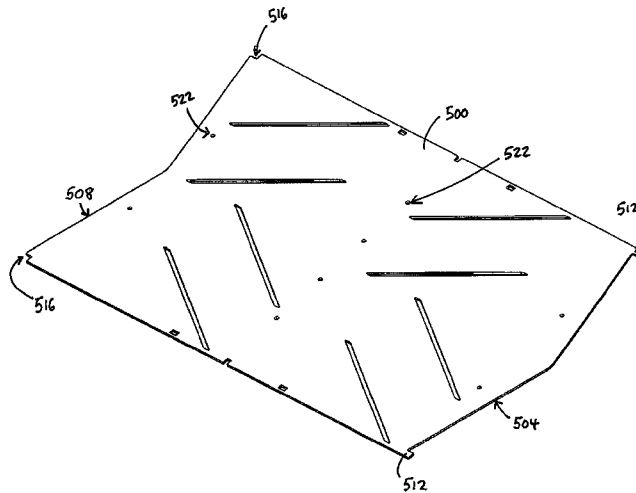

Fig. 26a

(57) Abstract: A conveyor system is provided, comprising an endless belt mounted in a longitudinal direction through the service line, the endless belt having an upper transport portion adapted to move a wheeled structure through a service line, and a lower return portion, a support deck positioned below the upper transport portion of the endless belt to support the endless belt, the support deck having a belt contact surface extending along a top of the support deck and in contact with the upper transport portion of the endless belt, the belt contact surface being constructed from a material that is at least partially thermoplastic, a belt rinsing system including a rinsing system conduit arrangement connectable to a source of rinsing system liquid, and at least one belt rinsing arrangement, wherein each of the at least one belt rinsing arrangement includes a rinsing system dirt pass-through aperture in the support deck.



MG, MK, MN, MW, MX, MY, MZ, NA, NG, NI, NO, NZ,
OM, PA, PE, PG, PH, PL, PT, QA, RO, RS, RU, RW, SA,
SC, SD, SE, SG, SK, SL, SM, ST, SV, SY, TH, TJ, TM, TN,
TR, TT, TZ, UA, UG, US, UZ, VC, VN, ZA, ZM, ZW.

- (84) Designated States** (*unless otherwise indicated, for every kind of regional protection available*): ARIPO (BW, GH, GM, KE, LR, LS, MW, MZ, NA, RW, SD, SL, ST, SZ, TZ, UG, ZM, ZW), Eurasian (AM, AZ, BY, KG, KZ, RU, TJ, TM), European (AL, AT, BE, BG, CH, CY, CZ, DE, DK, EE, ES, FI, FR, GB, GR, HR, HU, IE, IS, IT, LT, LU, LV, MC, MK, MT, NL, NO, PL, PT, RO, RS, SE, SI, SK, SM, TR), OAPI (BF, BJ, CF, CG, CI, CM, GA, GN, GQ, GW, KM, ML, MR, NE, SN, TD, TG).

Published:

- *with international search report (Art. 21(3))*
- *before the expiration of the time limit for amending the claims and to be republished in the event of receipt of amendments (Rule 48.2(h))*
- *in black and white; the international application as filed contained color or greyscale and is available for download from PATENTSCOPE*

BELT CONTACT SURFACE FOR CONVEYOR SYSTEM

CROSS-REFERENCE TO RELATED APPLICATIONS

[0001] This application claims the benefit of U.S. Provisional Application No. 62/598,641, filed December 14, 2017, the content of which is incorporated herein by reference in its
5 entirety.

FIELD

[0002] The present disclosure relates to the field of conveyor systems for transporting wheeled structures, and in particular to a conveyor system suitable for use in an automatic vehicle wash station.

BACKGROUND OF THE DISCLOSURE

[0003] Conveyor systems have long been used to assist in the transport of materials from one location to another, in particular with respect to heavy and cumbersome items. The use of conveyor systems in assembly lines is well documented, with perhaps Henry Ford being the most famous proponent of the technology of the 20th century.

15 [0004] Conveyors come in a variety of configurations, suiting a wide array of implementations. Belt conveyors in particular have been widely adopted due to their wide versatility and adaptability. For example, belt conveyors are commonly used in the warehousing, manufacturing, and mining sectors. More recently, belt conveyors have found

application in the automotive industry, in particular with respect to automated car wash stations.

[0005] Some car washes employ single or synchronous dual belt conveyor systems for moving the vehicle through the wash tunnel. The belts are made from plastics and metals
5 as these materials provide a relatively long life, and generally resist stretching and water corrosion.

[0006] The conveyor belts are supported by and travel across support decks that are conventionally made of a metal, such as steel or a steel alloy.

[0007] Over time, both the conveyor belts and the support decks wear mainly as a result
10 of friction between the automotive vehicle-laden conveyor belts and the support decks. This wear is exacerbated by the presence of debris that is commonly removed from automotive vehicles and trapped between the conveyor belts and the support decks during the washing process. As the conveyor belts and the support decks wear, they can fatigue and/or rupture, requiring their replacement. The replacement of the conveyor belts can be particularly costly
15 and labor-intensive.

SUMMARY OF THE DISCLOSURE

[0008] According to an aspect, there is provided a conveyor system, comprising: an endless belt mounted in a longitudinal direction through the service line, the endless belt having an upper transport portion adapted to move a wheeled structure through a service
20 line, and a lower return portion; a support deck positioned below the upper transport portion of the endless belt to support the endless belt, the support deck having a belt contact surface extending along a top of the support deck and in contact with the upper transport portion of

the endless belt, the belt contact surface being constructed from a material that is at least partially thermoplastic; a belt rinsing system including a rinsing system conduit arrangement connectable to a source of rinsing system liquid, and at least one belt rinsing arrangement, wherein each of the at least one belt rinsing arrangement includes a rinsing system dirt pass-
5 through aperture in the support deck, over which the upper transport portion of the endless belt travels during operation; and at least one rinsing system outlet from the rinsing system conduit arrangement positioned proximate to the rinsing system dirt pass-through aperture and positioned to eject rinsing system liquid onto the endless belt upstream from a downstream edge of the rinsing system dirt pass-through aperture in order to capture at
10 least some of the ejected liquid through the rinsing system dirt pass-through aperture.

[0009] The material can be at least partially thermoplastic. The material can be at least partially polyethylene. The material can be at least partially ultra-high-molecular-weight polyethylene. The material can be at least partially high-density polyethylene.

[0010] The belt contact surface can be formed of a set of wear plates formed from the
15 material. An expansion gap can be provided between the wear plates to allow for thermal expansion of the wear plates. The wear plates can have mating features inhibiting lateral shifting of the wear plates. Each wear plate can have a finger that extends longitudinally from a lateral end of one of the leading edge and the trailing edge that is received within a corresponding longitudinally extending recess on the other of the leading edge and the
20 trailing edge of an adjacent one of the wear plates.

[0011] According to another aspect, there is provided a wear plate for a conveyor system, the conveyor system having an endless belt mounted in a longitudinal direction through the service line, the endless belt having an upper transport portion adapted to move

a wheeled structure through a service line, and a lower return portion, a support deck positioned below the upper transport portion of the endless belt to support the endless belt, a belt rinsing system including a rinsing system conduit arrangement connectable to a source of rinsing system liquid, and at least one belt rinsing arrangement, wherein each of
5 the at least one belt rinsing arrangement includes a rinsing system dirt pass-through aperture in the support deck, over which the upper transport portion of the endless belt travels during operation, and at least one rinsing system outlet from the rinsing system conduit arrangement positioned proximate to the rinsing system dirt pass-through aperture and positioned to eject rinsing system liquid onto the endless belt upstream from a
10 downstream edge of the rinsing system dirt pass-through aperture in order to capture at least some of the ejected liquid through the rinsing system dirt pass-through aperture, the wear plate being dimensioned to extend along a top of the support deck and contact the upper transport portion of the endless belt, the wear plate having a corresponding rinsing system dirt pass-through aperture and being constructed from a material that is at least
15 partially thermoplastic.

[0012] According to a further aspect, there is provided a conveyor system, comprising: an endless belt mounted in a longitudinal direction through the service line, the endless belt having an upper transport portion adapted to move a wheeled structure through a service line, and a lower return portion, the endless belt being constructed from a first material
20 having a first hardness; a support deck positioned below the upper transport portion of the endless belt to support the endless belt, the support deck having a belt contact surface extending along a top of the support deck and in contact with the upper transport portion of the endless belt, the belt contact surface being constructed from a second material that has

a second hardness that is lesser than the first hardness; a belt rinsing system including a rinsing system conduit arrangement connectable to a source of rinsing system liquid, and at least one belt rinsing arrangement, wherein each of the at least one belt rinsing arrangement includes a rinsing system dirt pass-through aperture in the support deck, over which the upper transport portion of the endless belt travels during operation; and at least one rinsing system outlet from the rinsing system conduit arrangement positioned proximate to the rinsing system dirt pass-through aperture and positioned to eject rinsing system liquid onto the endless belt upstream from a downstream edge of the rinsing system dirt pass-through aperture in order to capture at least some of the ejected liquid through the rinsing system dirt pass-through aperture.

[0013] The second material can be at least partially thermoplastic. The second material can be at least partially polyethylene. The second material can be at least partially ultra-high-molecular-weight polyethylene. The second material can be at least partially high-density polyethylene.

[0014] The belt contact surface can be formed of a set of wear plates formed from the material. An expansion gap can be provided between the wear plates to allow for thermal expansion of the wear plates. The wear plates can have mating features inhibiting lateral shifting of the wear plates. Each wear plate can have a finger that extends longitudinally from a lateral end of one of the leading edge and the trailing edge that is received within a corresponding longitudinally extending recess on the other of the leading edge and the trailing edge of an adjacent one of the wear plates.

[0015] According to yet another aspect, there is provided a wear plate for a conveyor system, the conveyor system having an endless belt mounted in a longitudinal direction

through the service line, the endless belt having an upper transport portion adapted to move a wheeled structure through a service line, and a lower return portion, the endless belt being constructed from a first material having a first hardness, and a support deck positioned below the upper transport portion of the endless belt to support the endless belt, a belt
5 rinsing system including a rinsing system conduit arrangement connectable to a source of rinsing system liquid, and at least one belt rinsing arrangement, wherein each of the at least one belt rinsing arrangement includes a rinsing system dirt pass-through aperture in the support deck, over which the upper transport portion of the endless belt travels during operation, and at least one rinsing system outlet from the rinsing system conduit
10 arrangement positioned proximate to the rinsing system dirt pass-through aperture and positioned to eject rinsing system liquid onto the endless belt upstream from a downstream edge of the rinsing system dirt pass-through aperture in order to capture at least some of the ejected liquid through the rinsing system dirt pass-through aperture, the wear plate being dimensioned to extend along a top of the support deck and contact the upper transport
15 portion of the endless belt, the wear plate having a corresponding rinsing system dirt pass-through aperture and being constructed from a second material that has a second hardness that is lesser than the first hardness.

BRIEF DESCRIPTION OF THE DRAWINGS

[0016] The foregoing and other features and advantages of the disclosure will be
20 apparent from the following description of embodiments hereof as illustrated in the accompanying drawing. The accompanying drawings, which are incorporated herein and form a part of the specification, further serve to explain the principles of the disclosure and

to enable a person skilled in the pertinent art to make and use the disclosure. The drawings are not to scale.

[0017] Fig. 1 is a plan view of the conveyor system according to an embodiment hereof.

[0018] Fig. 2a is a partial side sectional view of the conveyor system according to the
5 embodiment of Fig. 1.

[0019] Fig. 2b is a partial side sectional view of the conveyor system with reference to line 2b-2b of Fig. 2a.

[0020] Fig. 2c is a partial side sectional view of the conveyor system with reference to line 2c-2c of Fig. 2a.

10 **[0021]** Fig. 3a is a partial isometric view of the conveyor system according to the embodiment of Fig. 1, highlighting features of the conveyor frame.

[0022] Fig. 3b is a partial isometric view of the conveyor system with reference to line 3b-3b of Fig. 3a.

[0023] Fig. 4 is a partial transverse sectional view of the conveyor system according to
15 Fig. 1, highlighting features in the region of the endless belt.

[0024] Fig. 5 is a partial transverse section view of the conveyor system according to Fig. 1, showing an alternative embodiment of the debris deflector.

[0025] Fig. 6 is a partial isometric of the debris deflector according to the embodiment of Fig. 5.

20 **[0026]** Fig. 7 is a partial isometric view of the conveyor system according to Fig. 1, showing the use of lateral guides on the idler end.

[0027] Fig. 8 is an enlarged isometric view of the lateral guide according to the embodiment of Fig. 7.

[0028] Fig. 9 is a partial isometric view of the conveyor system according to Fig. 1, detailing features of the mount brackets.

5 [0029] Fig. 10 is a partial isometric view of the conveyor system according to Fig. 1, detailing features of the wear plates.

[0030] Fig. 11 is a partial plan view of the conveyor system according to Fig. 1, detailing features of the wear plates.

10 [0031] Fig. 12a is a sectional view of one of the wear plates with reference to line 12a-12a of Fig. 11, showing features of the debris slot.

[0032] Fig. 12b is a sectional view of one of the wear plates with reference to line 12b-12b of Fig. 12a, showing features of the debris slot.

[0033] Fig. 13 is an enlarged sectional view of the guide member.

15 [0034] Fig. 14 is a partial sectional view of the guide member with reference to line 15-15 of Fig. 13, detailing features of the roller and thermoplastic bushing.

[0035] Fig. 15 is a partial sectional view of the guide member with reference to line 14-14 of Fig. 13, detailing features of a first end thereof.

[0036] Fig. 16 is an enlarged front view of an alternate embodiment of the guide member, showing the use of side rollers.

20 [0037] Figs. 17a-20 show a rinsing system for the conveyor system.

[0038] Figs. 21-25 show a flooding system for the conveyor system.

[0039] Figs. 26a-26c show wear plates according to an alternative embodiment.

[0040] Figs. 27a and 27b show wear plates according to other alternative embodiments.

[0041] Fig 28 shows the mating features of edge guides and wear plates according to an alternative embodiment.

5 **DETAILED DESCRIPTION**

[0042] The following detailed description is merely exemplary in nature and is not intended to limit the disclosure or the application and uses of the disclosure. A person skilled in the relevant art will recognize that other configurations and arrangements can be used without departing from the scope of the disclosure. Furthermore, there is no intention to be
10 bound by any expressed or implied theory presented in the preceding technical field, background, brief summary, or the following detailed description.

[0043] Reference is made to Fig. 1, which shows a service line 10 having a conveyor system 20 for moving a wheeled structure 11, in accordance with an embodiment. As used herein, the term service line is not intended to be restrictive, and may encompass for
15 example an automatic vehicle wash station (e.g., for cars, commercial trucks, etc.), a manufacturing or assembly line (e.g., for cars, trucks, non-powered mobile units, etc.) as well as a repair or detailing station (e.g., for cars, trucks, etc.). In addition, the term wheeled structure is not intended to be restrictive, and may encompass for example powered
20 landborne vehicles (e.g., trucks, automobiles, tractors, recreational vehicles, etc.), non-powered landborne mobile units (e.g., recreational trailers, utility trailers, etc.), and airborne vehicles (e.g., airplanes, etc.).

[0044] The conveyor system 20 is adapted to transport a wheeled structure along a longitudinal length of the service line 10. As presented in Fig. 1, service line 10 is shown in the form of a car wash station having a wash tunnel 22. Accordingly, the conveyor system 20 includes a service zone 24 within the region of the wash tunnel 22 through which the
5 vehicle is transported for a wash cycle. The conveyor system 20 also may also include a loading zone 26 adjacent a tunnel entrance 28, where vehicles align and initially load onto the conveyor system 20.

[0045] The conveyor system 20 is configured as a dual-belt system comprising a pair of endless belts mounted in a longitudinal direction through the service line 10. The endless
10 belts 36a, 36b are positioned in parallel and spaced-apart relationship relative to one another through the loading and service zones 26, 24. In the region between the pair of endless belts 36a, 36b, there may be positioned a central stationary platform 38 of removable panels that permit access to regions under the pair of endless belts 36a, 36b, in particular for servicing and maintenance. It will be appreciated that where the conveyor
15 system 20 is provided with two or more endless belts to transport the wheeled structure along the service line 10, the endless belts will move in synchronous motion. As the arrangement for each of the endless belts 36a, 36b is substantially identical, the endless belts 36a, 36b are herein collectively referred to as the endless belt 36 unless otherwise specified.

[0046] The endless belts 36a, 36b are made of a plurality of plastic belt segments that
20 are hingedly coupled via pins that are typically made of metal or plastic. The plastic of the belt segments has a hardness H_{BS} that enables the belt segments to withstand the load of a vehicle positioned thereon.

[0047] Turning now to Figs. 2a, 2b and 2c, the conveyor system 20 is generally supported within a trench 40 having a depth suitable to house the required drive and guide mechanisms, and to permit maneuverability to service personnel. The endless belt 36 has an upper transport portion 42 and a lower return portion 44, and extends along the conveyor system 20 between a drive end 46 and an idler end 48. The drive end 46 and idler end 48 provide axially elongated rollers 50 and 52, respectively, which are rotatably supported on a conveyor frame 54, to guide the endless belt 36 around the respective drive and idler ends 46 and 48.

[0048] The drive end 46 includes a drive module 56 adapted to engage and move the endless belt around the drive and idler ends 46 and 48. The drive module 56 may be an electric motor as shown, and may include at least one drive member 58 to engage the endless belt 36 and move it around the respective drive and idler ends 46 and 48. As shown, the drive member 58 is provided in the form of at least one sprocket 60 provided with sprocket teeth 62 to engage complementary tracks (not shown) on the inward surface 64 of the endless belt 36. The conveyor system 20 will additionally include guide members 66 supported upon the conveyor frame 54 to support the lower return portion 44 of the endless belt 36 as it moves back towards the idler end 48 on the underside of the conveyor system 20. As shown, the guide members 66 are provided in the form of rollers.

[0049] In motion, the upper transport portion 42 of the endless belt 36 moves in tension from the idler end 48 towards the drive end 46 by drive member 58, while the lower return portion 44 moves in a slackened state from the drive end 46 towards the idler end 48.

[0050] Turning now to Figs. 3a and 3b, shown is an enlarged view of the conveyor system 20 with the endless belt 36 and associated support structure removed to highlight

features of the conveyor frame 54. The conveyor frame 54 includes a plurality of cross-members 68 positioned transversely relative to the longitudinal direction of the service line 10. The cross-members 68 are dimensioned to span the width of the trench 40, and are adapted to mount on opposing surfaces 70 and 72. Each cross-member 68 also provides
5 at least one footing 74 at approximately a midpoint thereof, extending to a floor 76 of the trench 40 to provide additional load-bearing performance to the conveyor frame 54.

[0051] Arranged in the longitudinal direction, the conveyor frame 54 additionally provides a plurality of support rails that extend the longitudinal length of the service line 10, from the idler end 48 to the drive end 46. The support rails are arranged as two inner support rails
10 78a, 78b and two outer support rails 80a, 80b. The inner support rails 78a, 78b are generally positioned symmetrically about the longitudinal centerline of the service line 10, while the two outer support rails 80a, 80b are situated proximal to the longitudinal walls of the trench 40. The inner support rails 78a, 78b and the outer support rails 80a, 80b may be fixedly
15 attached in place by rivets, threaded fasteners (e.g., bolts), metallurgic bonding (e.g., welded attachment), or any other suitable means to achieve a secure attachment.

[0052] Having reference to Fig. 4, the inner support rails 78a, 78b cooperatively define a gap spacing for the central stationary platform 38 provided between the endless belts 36a, 36b. The inner support rails 78a, 78b each provide a respective seat 82a, 82b configured to receive and support the central stationary platform 38. In the embodiment shown, the central
20 stationary platform 38 is provided in the form of fiberglass or thermoplastic grating. In addition, for each endless belt 36, the respective opposing inner and outer rails 78a, 80a define a gap spacing to receive a support deck 84. The support deck 84 generally includes a plurality of modular grid panels 86 adapted to be positioned end to end relative to one

another along the longitudinal length of the service line 10. The modular grid panels are provided with a length that aligns the point of contact between adjacent grid panels on a transverse cross-member 68, providing weight-bearing support thereto. The support deck 84 is positioned between the upper transport portion 42 and lower return portion 44 of the endless belt 36, generally in close proximity to the upper transport portion 42. In this way, the support deck 84 provides support to the upper transport portion 42 of the endless belt 36, and thereby a load placed thereon from a wheeled structure placed upon the conveyor system 20. To facilitate sliding of the endless belt over the support deck 84, a belt contact surface in the form of a plurality of wear plates 88 is provided between the upper transport portion 42 and the support deck 84. The belt contact surface is the portion of the support deck 84 facing the endless belt 36 during normal use. The belt contact surface can have a thickness so that, as it wears through use with the endless belt 36, it continues to facilitate sliding of the endless belt 36 thereover until the belt contact surface is worn out.

[0053] The wear plates 88 form a structure that extends along a top of the support deck 84 and contacts the upper transport portion 42 of the endless belt 36. The arrangement of the inner and outer support rails 78a, 78b, 80a, 80b may additionally be used to mount the guide member 66 supporting the lower return portion 44 of the endless belt 36. As shown, the inner and outer support rails 78a, 80a provide respective guide hangers 90, 92 that support the guide member 66 in a transverse direction relative to the longitudinal direction of the service line 10. As shown, the guide member 66 is provided with a plurality of rollers 94 that support an outward surface 96 of the endless belt 36 along the lower return portion 44.

[0054] Continuing with Fig. 4, also provided between the upper transport portion 42 and the lower return portion 44 of the endless belt 36, and in particular between the support deck 84 and the lower return portion 44 is a debris deflector 98. The debris deflector 98 provides a barrier to protect the lower return portion 44 from debris falling from the support deck 84, in particular where the support deck 84 is provided in the form of the modular grid panels. The debris deflector 98 is generally mounted on an angle directed downwardly towards the longitudinal centerline of the service line. The debris deflector 98 may be mounted on dedicated brackets, or may be mounted on the guide hangers 90 and 92 used for supporting the guide members 66 (as shown). The debris deflector 98 is generally configured to provide a contiguous barrier between adjacent cross-members, so as to maximize the protection from falling debris. In some embodiments, the debris deflector 98 may be provided in the form of multiple panels arranged and fastened in side-by-side relationship to one another.

[0055] It will be recognized that the arrangement of the support deck 84, the debris deflector 98 and the longitudinally-spaced cross-members 68 define a partial enclosure in the region between the upper transport portion 42 and the lower return portion 44 of the endless belt 36. To assist in reducing the likelihood of freezing conditions on the conveyor system 10, in particular sections exposed to the outside environment, such as the loading zone 26 shown in Fig. 1, at least a portion of the conveyor system 20 may include a heater in these partial enclosures between adjacent cross-members 68. Referring to Figs. 3 and 4, the conveyor system 20 provides a heater 100 positioned between the support deck 84 and the debris deflector 98, extending in the longitudinal direction across one or more of the partial enclosures delimited longitudinally between adjacent cross members 68. Accordingly, the partial enclosures containing the heater 100 provide a region of higher heat

concentration relative to other areas within the trench 40, in particular the area below the debris deflector 98. In this way, the support deck 84, the endless belt 36 supported thereon, and the plurality of wear plates 88 positioned therebetween receive heat from the region of higher heat concentration, thereby reducing the likelihood of a freeze event in the conveyor system 20. It will be appreciated that freeze events in conveyor systems can result in extensive damage to the endless belt 36 and/or drive module 56.

[0056] To enable passage of the heater 100 between adjacent partial enclosures separated by the cross-members 68, the cross-members 68 are adapted with one or more pass-through apertures 102, depending on whether the heater is adapted to pass once through the desired heated portion, or in a serpentine path therethrough. In the embodiment shown in Fig. 4, two pass-through apertures are provided for each side of the conveyor system 20.

[0057] It will be appreciated that the heater 100 may take on a variety of forms. For example, the heater 100 may be configured as a convective heater, such as a convective tube heater including both smooth and finned-tube varieties. A convective tube heater will generally be part of a fluid circuit having an electric or gas-fired heater module to deliver a heated fluid therein. The heater 100 may also be configured as a radiant heater such as a gas-fired radiant tube heater, or a resistive electrical heating element.

[0058] The debris deflector 98 may be formed from any suitable material including but not limited to metal (e.g., stainless steel, galvanized steel, aluminum, etc.), thermoplastics (e.g., polypropylene, polyethylene, etc.) and composites. To promote direction of the emitted heat from heater 100 towards the support deck 84, the debris deflector 98 may be adapted with at least a selected level of thermal reflectivity. The thermal reflectivity may be achieved

by constructing the debris deflector 98 in the form of a radiant barrier. Alternatively, a radiant barrier may be separately formed and applied to the debris deflector 98, for example in the form of a thin radiant barrier sheet attached thereto. Radiant barriers are typically highly reflective materials (e.g., aluminum or polished stainless steel foil) applied to a substrate.

5 Exemplary substrates may include kraft paper, oriented strand board, plastic films and plywood. For environments that experience high moisture levels, for example a car wash tunnel, the substrate may be of metal or thermoplastic construction. Exemplary thermoplastic substrates may include polypropylene or polyethylene foam core. In general, the material applied to the substrate should exhibit an emittance of less than 0.25, as

10 measured by ASTM C1371. In addition to polished metallic films, low-emittance coatings such as metal oxide may be used on a suitable substrate. It will be appreciated that the side of the debris deflector 98, or separately formed sheet, facing the support deck 84 is the side adapted to receive the highly reflective material. In other words, the highly reflective material, and thus the effective side of the radiant barrier is intended to face the region of higher heat

15 concentration between the debris deflector 98 and the support deck 84.

[0059] Having regard to Figs. 5 and 6, shown is a debris deflector 198 according an alternative embodiment. As the debris deflector 198 is arranged in the conveyor system 20 in substantially the same way as debris deflector 98, only the differences associated with this alternative embodiment are discussed. The debris deflector 198 includes a debris

20 portion 110 that is positioned under the support deck 84, and a water collection portion 112 that extends outwardly therefrom, towards a respective side wall of the trench 40. The water collection portion 112 is intended to facilitate cleaning of the debris portion 110 of the debris deflector 198, without the need for substantial disassembly and associated downtime of the

conveyor system. With this arrangement, a sprayer or suitable wash nozzle 114 may be positioned as shown to deliver a stream of water directly upon the water collection portion 112 of the debris deflector 198, promoting a wash effect to remove accumulated debris from the debris portion 110. Access to the water collection portion 112 may be achieved by
5 removing side panels 116, or where the side panels 116 are provided in the form of fiberglass or thermoplastic grating, wash water may be delivered directly therethrough. The use of grates for the side panels 116 will also permit a greater volume of wash and rinse water from the wash tunnel to be captured by the water collection portion 112, enhancing the cleaning effect of the debris deflector 198 during normal wash tunnel usage.

10 **[0060]** As shown, the water collection portion 112 of the debris deflector 198 is generally arranged at an angle relative to the debris portion 110, with its terminal lateral edge 120 being positioned proximal the underside 122 of the side panel 116. The debris deflector 198 is provided with a curved transition 124 between the water collection portion 112 and the debris portion 110 to deflect the impingement of rinse water, with reduced turbulence,
15 therein resulting in an effective flushing of debris from the debris portion 110 of the debris deflector 198.

[0061] The debris deflector 98, 198 may be formed of stamped or formed stainless steel, or galvanized steel to provide a rust-inhibiting effect. In an alternative embodiment, the debris deflectors 98, 198 may be formed of a thermoplastic material, for example a
20 polyolefin, a low or high-density polyethylene, polyvinyl chloride, or an acrylonitrile butadiene styrene (ABS), and may include suitable fillers or additives to achieve the desired performance characteristics. In general, suitable materials will exhibit resistance to wear, corrosion and pitting, as well as low moisture absorption and low reactivity to chemicals.

Suitable materials should also exhibit a general non-stick behavior (i.e., as achieved through improved surface smoothness and a low coefficient of friction) in relation to oil and grease, as well as dirt and salt. In one embodiment, the debris deflector 98, 198 may be formed of polypropylene or polyethylene, and may include glass fibers to improve impact performance
5 at low temperature.

[0062] When formed of thermoplastic material, the debris deflector 98, 198 may be formed via any suitable molding process, including but not limited to vacuum forming, compression molding and thermoforming. When molded, a thermoplastic debris deflector may incorporate one or more structural ribs 126 (as seen in Fig. 6). The structural ribs 126
10 provide additional rigidity to the debris deflector 98, 198, and establish sluice-like channelways 128 that direct water flow, enhancing the wash effect.

[0063] As stated earlier, and having regard to Fig. 2a, the upper transport portion 42 of the endless belt 36 moves in tension from the idler end 48 towards the drive end 46 by drive member 56, while the lower return portion 44 moves in a slackened state from the drive end
15 46 towards the idler end 48. In the slackened state, the lower return portion 44 of the endless belt 36 may be subject to greater lateral movement, having the potential to create belt tracking and alignment issues. This is particularly evident at the idler end 48 where the axially elongated roller 52 is not provided with engagement teeth as found on the opposing drive member 58 at the drive end 46. Misalignment and poor tracking of the endless belt 36
20 can cause excessive wear on the conveyor mechanism, necessitating increased maintenance and associated downtime. Issues of misalignment of the endless belt 36 can increase upon aging of the endless belt 36, generally due to belt stretch. Accordingly, in an

alternative embodiment, a least one pair of lateral guide rollers are incorporated into the conveyor system 20.

[0064] Having regard to Fig. 7, shown is the idler end 48 of the conveyor system 20, with the endless belt and associated support components removed for clarity. Associated with
5 each endless belt is a pair of lateral guides 130a, 130b, mounted to the conveyor frame 54. The pair of lateral guides 130a, 130b are arranged to engage the lower return portion 44 of the endless belt 36, as best seen in Fig. 2c with respect to lateral guide 130b. Having regard to Figs. 7 and 8, each lateral guide 130a, 130b is provided with at least one roller (first roller
10 132) presenting a first roller surface 134 positioned to engage a respective lateral edge of the lower return portion 44 of the endless belt 36. In the embodiment shown, each lateral guide 130a, 130b is presented as having two stacked rollers, that is the first roller 132 and a second roller 136. The addition of the second roller 136 provides a second roller surface
15 138 positioned to engage the endless belt 36 in a more slackened state. In an alternative embodiment, the height of the first roller 132 can be large enough to span the expected range of the path of the endless belt 36, thereby mitigating the need for two or more rollers. In general, a newly installed endless belt 36 having very little operational time will exhibit less slack, and therein align to the first roller surface 134 of the first roller 132, as shown in
20 Fig. 2c. With usage and ageing of the endless belt, additional slack arising from stretch in the endless belt 36 may cause the endless belt 36 to displace downwardly, with the lateral edges of the lower return portion 44 aligning with the second roller surface 138 of the second roller 136. Further, changes in ambient temperature can cause the lengthening and shortening of the endless belt 36, causing it to align with the first roller surface 134 or the

second roller surface 138. Accordingly, the lateral guides 130a, 130b are configured to provide lateral support over the useable lifespan of the endless roller 36.

[0065] The lateral guides 130a, 130b generally include the at least one roller (first and second rollers 132, 136 as presented herein) mounted upon a bracket 140, as best seen in Fig. 8. The bracket 140 provides a mount portion 142 that is fastened to the conveyor frame 54, and a roller support portion 144 that receives the at least one roller (rollers 132, 136 in the embodiment shown). The rollers may be any suitable material, including but not limited to polymeric or rubber materials (i.e., rubber-tired caster wheels), and may include a suitable bushing or bearing to facilitate rotation about an axis A. In one embodiment, the bearing may be a sealed bearing to prevent the ingress and fouling of the bearing due to contaminated water and debris. To facilitate lateral adjustability of the lateral guides 130a, 130b, the mount portion 142 of the bracket 140 may be provided with a slotted aperture 146 at each point receiving a fastener (i.e., bolt 148). Accordingly, the lateral guides 130a, 130b can be laterally adjusted as necessary to ensure proper tracking of the endless belt 36. In general, the lateral guides are positioned to ensure continued traction with the edge of the endless belt 36, so as to minimize wear due to sliding friction, in particular with systems having heavier particulate buildup.

[0066] Having regard to Fig. 3a, each cross-member 68 may be adapted to mount directly upon the opposing surfaces 70 and 72, for example by welded attachment to an anchorage bar 150 embedded in the concrete at the upper longitudinal edge the trench 40. While effective, direct attachment can be labor intensive as supporting the heavy cross member 68 during attachment can be difficult. Accordingly, in an alternative embodiment, the plurality of cross members 68 are attached on opposing ends to a respective cross-

member mount bracket 152, as shown in Fig. 9. The cross-member mount bracket 152 includes an anchorage portion 154 configured for attachment to the anchorage bar 150, and a cross-member portion 156 configured to receive and support the cross-member 68. As shown, each side of the trench 40 includes along the upper longitudinal edge 158 the anchorage bar 150, generally provided in the form of angle iron embedded in the concrete. At each location along the trench 40 where a respective cross-member 68 is positioned, a mount bracket 152 is welded to the anchorage bar 150. The mount bracket 152 is easier to locate in relation to a desired vertical elevation on the anchorage bar 150, and may be tack-welded in place prior to permanent attachment to enable alignment and level verification over the longitudinal length of the trench prior to final welding. With all mount brackets 152 welded in position to support the desired arrangement of cross-members 68, the cross-members are attached at opposing ends to respective cooperating mount brackets. Attachment may be achieved using suitable fasteners, for example bolts 160. To permit for lateral adjustment, in particular where the trench 40 may exhibit variation in width along its longitudinal length, the cross-member mount portion 156 of at least one of the cooperating mount brackets 152 is provided with slotted apertures 162 to receive the fastener (bolts 160). In this way, slight variations in width of the trench 40 are accommodated by the mount brackets 152, reducing the need for custom-sized components. This slotted arrangement also allows adjustment of the conveyor system 20 for straightness in the event that the trench 40 is not straight.

[0067] As stated previously, the wear plates 88 facilitate sliding of the endless belt 36 over the support deck 84, and is located between the upper transport portion 42 and the support deck 84, as best seen in Fig. 4. Having regard to Figs. 10 and 11, shown is a portion

of the conveyor system 20 with the endless belt removed to highlight features of the wear plates 88. The wear plates 88 are supported upon the plurality of modular grid panels 86 of the support deck 84, and are adapted to sit end-to-end relative to one another. Each of the wear plates 88 includes a leading edge 166 and a trailing edge 168, wherein the leading and trailing edges 166 and 168 are provided with complementary profiles to facilitate fit and alignment between adjacently positioned wear plates 88. In the embodiment shown, the complementary profile is provided in the form of a chevron aligned to the direction of travel of the vehicle through the wash tunnel. At least one of the leading and trailing edges 166 and 168 of the wear plates 88 may be chamfered to reduce the likelihood of wear upon the endless belt.

[0068] The wear plates 88 are made from a material that is at least partially thermoplastic, and, in particular, at least partially polyethylene, such as an ultra-high-molecular-weight polyethylene (“UHMWPE”), which is also known as high-modulus polyethylene (“HMPE”). UHMWPE is a thermoplastic polyethylene that has extremely long chains. The longer chains serve to transfer load more effectively to the polymer framework by reinforcing intermolecular interactions. Further, UHMWPE has low moisture absorption, a very low coefficient of friction, a high strength, and is highly resistant to abrasion as a result of the longer chains, especially in comparison to carbon steel. Further, UHMWPE is very resistant to corrosion. Some particular exemplary materials that can be used to manufacture the wear plates are virgin UHMWPE such as available from Röchling Engineering Plastics and the Garland Manufacturing Company, reprocessed UHMWPE such as available from Röchling Engineering Plastics, glass filled UHMWPE such as available from Quadrant Plastic Composites Inc., ceramic filled UHMWPE such as available from Polymer Industries

Inc. and Quadrant Plastic Composites Inc., and cross-linked UHMWPE such as available from Röchling Engineering Plastics and Polymer Industries Inc.

[0069] Alternatively, in other embodiments, the wear plates can be made from a material that is at least partially high-density polyethylene (“HDPE”). HDPE is also suitable for use
5 for construction of the wear plates 88. In another embodiment, a proprietary polyethylene, Polystone™ sold by Röchling Engineering Plastics, can be used to manufacture the wear plates.

[0070] The material of the wear plates 88 can be selected it has a hardness H_{WP} that is lesser than the hardness H_{BS} of the plastic belt segments in some scenarios.

10 **[0071]** The costs for the manufacturing of wear plates form these materials ranges from 63% to over 200% of the price using stainless steel in some cases, based on the current prices of stainless steel and these thermoplastics. Depending on the material selected and application, suitable thickness ranges are in the 3/16 inch to 3/8 inch range (5-10 mm) in some scenarios.

15 **[0072]** Traditionally, the use of such materials for belt contact surfaces was deemed unsuitable as dirt trapped between the endless belts and the belt contact surfaces caused the belt contact surfaces to wear at an unsatisfactory rate without significant improvements to the wear of the endless belts. Wearing of the endless belts and the belt contact surface occurs in the form of erosion. As the endless belts are worn down, the pins holding belt
20 segments together are exposed and can be deformed and pop out, allowing the belt segments to separate. Erosion of the belt contact surface can accelerate endless belt wear where the endless belt is in contact with the underlying structures.

[0073] It has been found that, by using a belt rinsing system that introduces and drains a rinsing fluid between the endless belts and the belt contact surfaces, the dirt trapped between the endless belts and the belt contact surfaces can be reduced and that the wear rate of both the endless belts and the belt contact surfaces can be reduced.

5 **[0074]** That is, by making the belt contact surface (i.e., the wear plates 88) from a softer material than stainless steel that is traditionally used, and by rinsing away debris from the interface between the endless belts 36a, 36b and the support deck, the lifetime of the endless belts 36a, 36b can be increased as a result of the lower wear from contact with the wear plates 88.

10 **[0075]** Certain thermoplastics, such as UHMWPE and HDPE have been found to be suitable due to their possession of certain characteristics. These materials provide a sufficiently low coefficient of friction, and are sufficiently resistant to abrasion. The wear plates 88 are inexpensive to replace relative to the replacement cost of the endless belts 36a, 36b. The replacement cost of an endless belt 36a, 36b can be high as there is a
15 significant amount of manual labor in disassembling the belt segments to be replaced. Wear plates made from a material that is substantially UHMW have been found to have a service lifetime that ranges from 11% to 200% of the durability of wear plates made from stainless steel. Of more interest is that, due to the relative softness, higher resistance to abrasion, and lower coefficient of friction of the material compared to stainless steel traditionally
20 employed in these applications, the wear rate of the endless belts is reduced, thus extending their service lifetime significantly, anywhere from 50% to 1700% in some cases.

[0076] Another characteristic of thermoplastics is that they generally have a hardness H_{WP} that is lesser than the hardness H_{BS} of the belt segments of the endless belts 36a, 36b.

As a result, the wear plates 88 are designed to improve the lifetime of the endless belt 36 by sacrificing the lifetime of the wear plates 88.

[0077] Polyethylenes and other thermoplastics are subject to thermal expansion and contraction. In the car wash environment, the range of temperatures that the wear plates 88 are subject to is significant. The wear plates 88 have a longitudinal length of approximately 44 inches and have been found to expand and contract +/- 0.2 inches over a typical operational ambient temperature range. In order to compensate for these expansions and contractions, expansion gaps between the leading and trailing edges 166 and 168 of the wear plates 88 of 0.2 inches or greater are provided.

[0078] Each wear plate 88 is provided with a plurality of debris slots 170 that permit the evacuation of debris therethrough, so as to reduce the accumulation of debris between the endless belt and the wear plates 88. Each debris slot 170 includes a first slot end 172 and a second slot end 174, and is provided with a width of 10 mm, although widths of between 8 to 25 mm may be implemented. Each debris slot 170 may be linear (i.e., straight) and may be arranged at an angle θ relative a longitudinal centerline L of the wear plate 88. As shown, the debris slot 170 is outwardly angled from the longitudinal centerline L in the direction of the first slot end 172 towards the second slot end 174. The angle θ of each debris slot 170 is 35° relative to the longitudinal centerline L of the wear plate 88, although angles between 25° to 45° may be implemented. In general, angle selection is based on observed belt wear. It has been determined that angles within this range, and in particular at 35° relative to the longitudinal centerline L of the wear plate 88 result in the least amount of endless belt wear during use, therein increasing the usable lifespan of the endless belt and wear plates.

[0079] The first slot end 172 and the second slot end 174 of each debris slot 170 can be provided with an inwardly sloped bevel 176, as shown in Fig. 12a. It has been determined that maximum wear of the endless belt occurs where the endless belt passes over a sharp edge perpendicular to the direction of belt travel. Accordingly, with the first and second slot ends 172 and 174 having the inwardly sloped bevel 176, in particular at the second slot end 174, the extent of belt wear is reduced, particularly when the wear plates are constructed of stainless steel. Between the first and second slot ends 172 and 174 of the debris slot 170, the opposing edges 178a and 178b remain unbeveled, that is they remain as sharp edges, as shown in Fig. 12b. As the endless belt is passing over these sections of the debris slot 170 at an angle (i.e., 35° relative to the longitudinal centerline L of the wear plate 88), the extent of belt wear is minimal. Moreover, by maintaining these edges sharp as shown, they provide a stripping action to remove debris from the underside of the endless belt, without excessive wear thereto.

[0080] It will be appreciated that while both the first and second slot ends 172 and 174 are shown as being beveled, in some embodiments, only one of the first and second slot ends 172 and 174 is beveled. In an alternative embodiment, only the second slot end 174 is beveled.

[0081] By using certain thermoplastics that are softer than stainless steel, have a low coefficient of friction, and/or a high resistance to abrasion in constructing the wear plates, it has been found that the beveling of the debris slots 170 as shown in Figs. 12a and 12b can be omitted without materially increasing wear on the endless belt 36. The beveling of the debris slots 170 adds to the manufacturing costs of the wear plates 88 and, thus, the ability

to omit this feature without materially impacting the lifetime of the endless belt 36 is another benefit to the use of thermoplastics in the construction of the wear plates 88.

[0082] In the embodiment shown in Fig. 11, each wear plate 88 provides 8 debris slots 170, generally presented in two rows of 4 arranged across the wear plate 88. Within each
5 row, the 4 debris slots are arranged in two paired sets of debris slots, with the two paired sets of debris slots being longitudinally offset relative to one another. The arrangement of the debris slots 170 is such that the leading and trailing ends 172 and 174 of successive debris slots 170 align, so as to reduce the number of locations having increased potential for belt wear. As shown, alignment between successive debris slots occurs along
10 longitudinal centerline L, as well as alignment line AL_A and alignment line AL_B.

[0083] It will be appreciated that while each wear plate 88 is shown as having 8 debris slots 170, in other embodiments, the number of debris slots 170 may be fewer or greater, depending on the extend of debris removal required. While the leading and trailing ends 172 and 174 of all debris slots 170 may be machined with the aforementioned inwardly sloped
15 bevel, in some embodiments, only the debris slots 170 arranged proximal the longitudinal centerline L of the wear plate 88 may be beveled. In other preferred embodiments, the debris slots 170 are not beveled.

[0084] As shown in Fig. 4, the inner and outer support rails 78a, 80a provide respective guide hangers 90, 92 that support the guide member 66 in a transverse direction relative to
20 the longitudinal direction of the service line 10. Having regard to Fig. 13, shown is the guide member 66 in isolation to highlight specific features thereof. Guide member 66 includes a plurality of rollers 94 (94a, 94b, 94c) mounted on a stationary shaft 180 supported at a first end 182 by guide hanger 90 (not shown for clarity), and at a second end 184 by guide

hanger 92. In some embodiments the stationary shaft 180 is a stainless steel shaft, with at least one of the first and second ends 182 and 184 being configured with a suitable keyed interface with respective guide hangers 90 and 92 to prevent rotation of the stationary shaft 180 relative thereto. Each roller 94 (94a, 94b, 94c) provided is rotatably mounted on the stationary shaft 180 using a suitable bushing or bearing interface therebetween. In the 5 embodiment shown, a low friction thermoplastic bushing 186 is used. Suitable thermoplastics include, but are not limited to acetal (i.e., Delrin™) and UHMWPE. As shown in Fig. 14, the thermoplastic bushing 186 is configured with a central portion 188 that engages a shaft aperture 190 of roller 94, as well as a first bushing extension 192 and a 10 second bushing extension 194. The central portion 188 of the thermoplastic bushing 186 is press-fit or otherwise mounted in the shaft aperture 190, so as to rotate with the roller 94. Accordingly, upon rotation of the roller 94 during use, the thermoplastic bushing 186 rotates upon the stationary shaft 180, with the thermoplastic bushing 186 providing a low friction interface therebetween.

15 **[0085]** The guide member 66 additionally includes a series of protective sleeves that cover the stationary shaft 180 and serve to protect the interface between the stationary shaft 180 and the thermoplastic bushings 186 from debris and contaminated water. As shown, a first and second outer sleeve 196 and 198 is provided between respective guide hangers 90 and 92 and the outer rollers 94a and 94b. A first and a second inner sleeve 200 and 202 20 are provided between the respective outer rollers 94a and 94b and the middle roller 94c. It will be appreciated that the inner and outer sleeves also serve as spacers to maintain the rollers 94 in the desired position on the stationary shaft 180.

[0086] The first and second outer sleeves 196 and 198 are configured to remain stationary during use. Accordingly, at each end 182 and 184 of the stationary shaft 180, a fixed non-rotatable interface is established between the stationary shaft 180 and the first and second outer sleeves 196 and 198 associated therewith. Having regard to Fig. 15
5 detailing the arrangement at the first end 182, a fixed bushing 204 is provided between the first outer sleeve 196 and the stationary shaft 180. The interface between the stationary shaft 180 and the fixed bushing 204, in particular the outside diameter of the stationary shaft 180 relative to the inside diameter of the fixed bushing 204 is sized to establish an interference fit therebetween. As such, a fixed non-rotatable relationship is established
10 between the stationary shaft 180 and the fixed bushing 204. Similarly, the interface between the fixed bushing 204 and the first outer sleeve 196, in particular the outside diameter of the fixed bushing 204 relative to the inside diameter of the first outer sleeve 196 is sized to establish an interference therebetween. As such, a fixed non-rotatable relationship is established between the fixed bushing 204 and the first outer sleeve 196. Accordingly, the
15 first outer sleeve 196, as well as the second out sleeve 198 which is mounted in an identical manner relative to the second end 184 remain fixed in relation to the stationary shaft 180.

[0087] On the opposing end of the first outer sleeve 196, that is where it engages the first bushing extension 192 of the thermoplastic bushing 186 at the roller 94a, the inside diameter of the first outer sleeve 196 relative to the outside diameter of the first bushing
20 extension 192 is sized to establish a slip-fit therebetween. As such, first outer sleeve 196 remains fixed while the thermoplastic bushing 186 is permitted to rotate relative thereto. It will be appreciated that the opposing end of the second outer sleeve 198 is similarly

configured relative to the thermoplastic bushing 186 at the roller 94b, so as to achieve the same slip-it relationship therebetween.

[0088] Unlike the first and second outer sleeves 196, 198, the first and second inner sleeves 200 and 202 are configured to rotate with the rollers 94. Accordingly, having regard
5 to the first inner sleeve 200, the interface between the first inner sleeve 200 and the second bushing extension 194 at roller 94a, in particular the inside diameter of the first inner sleeve 200 relative to the outside diameter of the second bushing extension 194 is sized to establish an interference fit therebetween. Each end of the first inner sleeve 200 is configured in this way, therein causing the first inner sleeve 200 to rotate upon rotation of the rollers 94a and
10 94c. It will be appreciated that the second inner sleeve is similarly configured, relative to the rollers 94c and 94b.

[0089] To reduce the likelihood of contamination of the thermoplastic bushing 186, in particular at the interface between the thermoplastic bushing 186 and the stationary shaft 180, additional seal rings 206 (i.e., rubber O-rings) may be implemented. As shown, a seal
15 ring 206 is provided at the interface between each bushing extension 192 and 194 of the thermoplastic bushing 186, and the respective inner sleeve 200 and 202 or outer sleeve 196, 198 to which it engages. Seal ring is seated in a suitable channel at the interface, for example as provided by seal ring channel 210 in each of the first and second bushing extensions 192 and 194.

[0090] Suitable materials for the rollers 94 include, but are not limited to rubber tired wheels (i.e., caster wheels). The use of rubber tired wheels has the benefit of supporting the
20 endless belt without causing damage to the belt surfaces by maintaining traction sufficient to provide continuous rotation of the wheels with belt movement.

[0091] It will be appreciated that while the stationary shaft 180 is shown as being solid, in an alternative embodiment, the stationary shaft 180 may be a hollow tube.

[0092] In an alternative embodiment, each guide hanger 90 and 92 may additionally include a side roller 208, for example as shown in Fig. 16. The side roller 208 may be a
5 rubber tired wheel similar to the rollers 94 of the guide members 66, and are configured to engage the edge of the endless belt 36, maintaining the endless belt 36 laterally centered relative to the opposing guide hangers 90 and 92.

[0093] Reference is made to Figs. 17a-20, which shows the conveyor system 20 with an optional rinsing system 300. The rinsing system 300 includes a rinsing system conduit
10 arrangement 302 (a portion of which is shown in Figs. 17a and 17b), which is connectable to a source of rinsing system liquid (e.g., a city water supply). The rinsing system 300 further includes at least one belt rinsing arrangement 304. In the present example, the rinsing system 300 includes a plurality of belt rinsing arrangements 304 spaced longitudinally apart for rinsing the upper transport portion 42 of the endless belt 36.

15 [0094] Each belt rinsing arrangement 304 includes a rinsing system dirt pass-through aperture 306 in the support deck 84, over which the upper transport portion 42 of the endless belt 36 travels during operation. As can be seen, in the embodiment shown in Figure 17a, the rinsing system dirt pass-through aperture 306 is provided in a rinsing system wear plate
20 308. The rinsing system dirt pass-through aperture 306 may be similar to the debris slots 170 in the wear plates 88, but may be wider in the direction of travel (shown at Dt) of the endless belt 36 for reasons provided below.

[0095] Each belt rinsing arrangement 304 further includes at least one rinsing system outlet 310 from the rinsing system conduit arrangement 302 positioned proximate to the rinsing system dirt pass-through aperture 306a and positioned to eject rinsing system liquid (shown at 312 in Figs. 18 and 19) onto the endless belt 36 upstream from a downstream edge 314 of the rinsing system dirt pass-through aperture 306a in order to capture at least some of the ejected liquid 312 through the rinsing system dirt pass-through aperture 306a. The terms 'upstream' and 'downstream' are both in relation to the direction of travel D_t of the upper transport portion 42 of the endless belt 36. The upstream edge of the rinsing system dirt pass-through aperture 306a is shown at 315. Additional rinsing system dirt pass-through apertures 306b enables the flushing of ejected liquid 312 downstream of the rinsing system dirt pass-through apertures 306a.

[0096] Put another way, the rinsing system 70 can rinse off dirt from the endless belt 36 so as to prevent that dirt from causing wear on the belt 36 as the belt 36 moves along during operation. The dirt may be present directly at the sliding interface between the belt 36 and the wear plates 88 and 308. Additionally, the dirt may be present at the pins (shown at 316) that pivotally connect belt segments (shown at 318) that make up the belt 36.

[0097] Pockets (shown at 320) are present in the endless belt 36 and some portions of the pins 316 are exposed in the pockets 320. It is therefore beneficial for the rinsing system 300 to be able to eject rinsing system liquid into the pockets 320 to rinse dirt from the pins 316. This inhibits dirt from migrating into the interface between the pins 316 and the associated surfaces of the belt segments 318, which reduces the wear that can occur on the belt segments 318 at that interface. Such wear contributes to ovalizing of the apertures

in the belt segments 318 in which the pins 316 reside, causing the belt 36 to lengthen and contributing to accelerated wear and failure of the belt 36.

[0098] Thus it may be said that the endless belt includes a plurality of belt segments 318 that are pivotally connected to one another via at least one pin 316 that extends laterally.

5 The endless belt 36 includes at least one pocket 320 that exposes the at least one pin 316. The at least one rinsing system outlet 310 is positioned to eject rinsing system liquid into the at least one pocket 320 onto the at least one pin 316 to remove dirt from the at least one pin 316.

[0099] The rinsing system outlet 310 may be any suitable type of outlet that is capable
10 of ejecting rinsing system liquid the distance needed to remove dirt from the endless belt 36. In some examples, the pressure of the rinsing system liquid at the rinsing system outlet 310 may be about 20 psi or higher. In some examples, it may be 40 psi or higher. The rinsing system outlet 310 may, for example, be a nozzle.

[0100] Reference is made to Figure 20. As can be seen, the rinsing system outlets 310
15 are positioned below the wear plates 308 and are positioned to eject the rinsing system liquid up through the rinsing system dirt pass-through aperture 306 into the belt 36. The rinsing system dirt pass-through aperture 306 has an elongate cross-sectional shape and is sized to permit the ejecta 312 (i.e., the rinsing system liquid ejected therefrom) to leave upwardly from the rinsing system dirt pass-through aperture 306, to hit the endless belt 36
20 and to fall through the rinsing system dirt pass-through aperture 306 after hitting the endless belt, bringing dirt with it, as shown in Fig. 20. For example, in the embodiment shown, the outlet 310 is well below the wear plate 308 and so the ejecta 312 pass upwardly through the

rinsing system dirt pass-through aperture 306, hit the belt 36 and then fall back down through the aperture 306.

[0101] The apertures 306 are shown as being angled, similarly to the apertures (slots) 170 in the wear plates 88, for the purpose of ensuring that segments of the belt 36 are
5 always supported and do not impact against an aperture edge. This is the same reason described for the angle of the slots 170. Similar angular ranges may be used for the orientation (i.e., the angle) of the apertures 306.

[0102] As can be seen, each rinsing system outlet 310 is in the form of a fan jet nozzle configured for ejecting rinsing system liquid 312 in the form of ejecta 312 having an elongate
10 cross-sectional shape (e.g., a flat spray pattern).

[0103] Referring to Fig. 19, dashed lines shown at 330a and 330b represent the side edges of the endless belt 36. The belt 36 has a width W. As can be seen, the at least one belt rinsing arrangement 302 includes enough of the rinsing system outlets 306 to eject rinsing system liquid 312 (i.e., ejecta 312) on the entire width of the belt 36. There is some
15 offset between the apparent position of the ejecta 312 and the position of the side edges 330a and 330b of the belt 36 in the view shown in Fig. 19 however, it will be understood that this is merely a result of the difference in elevation of the outlets 310 and the belt 36.

[0104] In Fig. 19, a debris deflector 332 is provided and may be similar to any of the debris deflectors shown and described herein. The debris deflector 332 is positioned
20 underneath the rinsing system dirt pass-through aperture 306 to collect dirt falling through the rinsing system dirt pass-through aperture 306, and sloped downwardly away from the

rinsing system dirt pass-through aperture 306 in order to transport collected dirt towards a dirt collection area shown at 334.

[0105] Reference is made to Figs. 21 and 22, which show another rinsing system 340, which includes a rinsing system conduit arrangement 342 which is connectable to a source of rinsing system liquid (e.g., a city water supply or a reclaim water system). The rinsing system 340 further includes at least one sprocket rinsing arrangement 344 configured to rinse and remove dirt from a sprocket arrangement 352 that is used to drive the belt 36. The sprocket arrangement 352 in the present example includes a plurality of sprockets 354 that are mounted on a drive shaft 356. Alternatively, the sprocket arrangement 352 could include a single sprocket 354.

[0106] The drive shaft 356 in the present example is square and passes through square apertures in the sprockets 354, however it will be understood that other shapes for the drive shaft 356 and apertures are possible. The sprocket arrangement 352 has sprocket teeth 358 that engage the belt 36 to drive the belt 36. The direction of rotation of the sprocket arrangement 352 is shown at Ds in Fig. 21.

[0107] Each belt rinsing arrangement 344 further includes at least one rinsing system outlet 360 from the rinsing system conduit arrangement 342. The at least one rinsing system outlet 360 is positioned proximate to the sprocket arrangement 352 and is positioned to eject rinsing system liquid 312 onto the sprocket arrangement 352.

[0108] As rinsing system liquid 312 is ejected onto the sprocket arrangement 352, it rinses some dirt off a portion of the surface of the sprocket arrangement 352 prior to engagement between that portion of the surface of the sprocket arrangement 352 and the

belt 36. As a result, there is less dirt that would cause wear of the belt 36 during engagement with the sprocket arrangement 352. Such wear on the belt 36 can reduce the efficacy of the engagement with the teeth 358 on the sprocket arrangement 352. Additionally, the presence of the dirt itself can inhibit good engagement between the teeth 358 and the belt 36 which
5 can result in increases stresses on certain areas of the belt 36 during such engagement.

[0109] A debris collection guide 362 is provided underneath the at least one rinsing system outlet 360 to collect at least some of the liquid that has hit the sprocket arrangement 352 and reflected or dripped off the sprocket arrangement 352 thereafter along with any dislodged dirt or any dirt entrained in the reflected liquid or the liquid that has dripped off the
10 sprocket arrangement 352. The debris collection guide 362 guides collected debris to a debris collection area (not shown).

[0110] Some rinsing system liquid 312 may wind up on the lower return portion 44 of the belt 36 instead of in the debris collection guide 362. This is not considered problematic, since the inner surface of the lower return portion (shown in Fig. 21 at 364) does not engage any
15 surfaces with significant force until reaching the idler drum at the other end of the conveyor system 20. Some of the dirt and liquid collected on the inner surface 364 of the lower return portion 44 of the belt 36 will have fallen off the belt 36 by the time it reaches the other end. As noted above, the rinsing system 300 can be provided at the upstream end of the upper transport portion 42 of the conveyor system 10, so as to rinse off dirt thereon prior to a lot of
20 sliding engagement with the wear plates 88.

[0111] Figure 22 is a perspective view of the rinsing system 340, but with the sprocket arrangement 352 removed. As shown in Figure 22, the rinsing system outlets 360 may be in the form of fan (flat spray) jet nozzles, and may be configured to eject rinsing system liquid

312 in flow patterns that overlap with one another and which are configured to cover the width of the sprocket arrangement 352.

[0112] As can be seen in Figures 21 and 22, optionally, the rinsing system 340 further includes at least one belt rinsing arrangement including at least one rinsing system outlet 5 360 positioned to spray rinsing system liquid 312 on the outer face (shown at 366) of the belt 36, to further clean the belt 36 while the belt 36 is engaged with the sprocket arrangement 352.

[0113] Reference is made to Figs. 23 and 24, which show a flooder system 400 for the conveyor system 20. The flooder system 400 is used to introduce liquid between the endless 10 belt 36 and the wear plate (e.g., wear plate 88 or wear plate 308). The flooder system 400 includes a flooder system conduit arrangement 402 connectable to a source of flooder system liquid (such as city water, or a source of city water mixed with soap, wax or some other lubricant), and at least one belt flooding member 404. Each belt flooding member 404 includes at least one flooding system outlet 406 (and optionally a plurality of outlets 406 15 which are spaced apart laterally) from the flooding system conduit arrangement 402. The outlet or outlets 406 are positioned underneath the endless belt 36 and are positioned to introduce flooding system liquid 408 between the endless belt 36 and the wear plate. The liquid 408 introduced helps to reduce friction between the belt 36 and the wear plate 88 or 308 in part by entraining dirt that may be present therebetween.

20 **[0114]** The liquid pressure at the outlets 406 may be relatively low, lower than the pressure at the outlets 310. For example, the pressure may be about 2 psi, but is preferably higher, such as in the range of 5-10psi or even higher.

[0115] The support deck (e.g., the wear plates 88 and 308) includes a plurality of dirt pass-through apertures as described above. These apertures will permit the dirt and liquid from the flooding system to fall through, thereby removing dirt from the interface between the belt 36 and the wear plates 88 and 308. The flooding system 400 may include a plurality of belt flooding members 404 positioned at selected distances longitudinally from one another, such as, for example, about every 20 to 30 feet from one another. Optionally, each belt flooding member 404 is positioned between gratings 412 that support the wear plate 88 or 308 and thus may act as a spacer between these gratings 412. The gratings 412 need not be gratings and may also be identified more broadly as wear plate support members 412. The wear plate 88 or 308 has flooding system apertures 414. Each flooding member 404 may include a bar 416 that acts as a manifold and that has a plurality of outlets 406 thereon. The flooding member 404 may further include seal members 418 (e.g., rubber bushings) that are positioned between the outlets 406 and the underside (shown at 420) of the wear plate 88 or 308 to form a seal therebetween.

[0116] Figs. 26a to 26c show wear plates 500 in accordance with another embodiment. The wear plates 500 are similar in size and construction to wear plates 88 shown in Figs. 10, 11, 17a, and 17b. In particular, each of the wear plates 500 includes a leading edge 504 and a trailing edge 508, wherein the leading and trailing edges 504 and 508 are provided with complementary profiles to facilitate fit and alignment between adjacently positioned wear plates 500. In the embodiment shown, the complementary profile is provided generally in the form of a chevron aligned to the direction of travel of the vehicle through the wash tunnel. At least one of the leading and trailing edges 504 and 508 of the wear plates 500 may be chamfered to reduce the likelihood of wear upon the endless belt.

[0117] Like the wear plates 88, the wear plates 500 expand and contract with temperature changes. To allow for this expansion and contraction, the wear plates 500 are secured via fasteners inserted through fastener holes 522 that fit within slotted holes of the modular grid panels of the support deck. This arrangement allows a degree of freedom of movement (or, more to the point, expansion) of the wear plates 500. It can also be desirable to maintain the leading and trailing edges 504 and 508 in lateral alignment to avoid changes in the lateral profile of the belt contact surface (i.e., the wear plates 500) in the longitudinal direction that can serve to more quickly wear and/or damage the endless belt.

[0118] To this end, the wear plates 500 have mating features inhibiting lateral shifting of the wear plates 500 relative to one another in the form of fingers 512 that extend longitudinally (i.e., generally along the direction of travel of the endless belt) forward from lateral ends of the leading edges 504, and corresponding finger recesses 516 that extend longitudinally from lateral ends of the trailing edges 508. The fingers 512 mate with the finger recesses of adjacent wear plates 500 to maintain the wear plates 500 in lateral alignment while the wear plates 500 expand to reduce an expansion gap 518 between the wear plates 500, and contract.

[0119] In other embodiments, the fingers can extend longitudinally from the trailing edge and mate with corresponding finger recesses of the leading edge of an adjacent wear plate. Alternatively, a finger and a recess can be located on opposite lateral ends of each leading and trailing edge and mate with the corresponding features of adjacent wear plates. Other types of mating features that inhibit lateral shifting of the wear plates will occur to those skilled in the art.

[0120] The wear plates 500 also have debris slots 520 that permit the evacuation of debris therethrough, so as to reduce the accumulation of debris between the endless belt and the wear plates 500.

[0121] Figs. 27a and 27b show two variants of the design of the wear plates. A wear plate 600 shown in Fig. 27a has fingers 604 that extend longitudinally (i.e., generally along the direction of travel of the endless belt) forward from lateral ends of the leading edge 606, and corresponding finger recesses 608 that extend longitudinally from lateral ends of the trailing edge 610. The fingers 604 mate with the finger recesses of adjacent wear plates 600 to maintain the wear plates 600 in lateral alignment while the wear plates 600 expand to reduce an expansion gap between the wear plates 600, and contract. A set of four locating slots 612 are positioned two along each lateral side of the wear plate 600. The wear plate 600 has a pattern of debris slots 616 that differs from those shown in the previous figures. In particular, the debris slots 616 are wider and shorter, enabling ample drainage without significantly affecting the structural integrity of the wear plate 600. That is, there are no portions of the wear plate 600 that are connected to the remainder of the wear plate 600 only by narrow sections.

[0122] A wear plate 620 shown in Fig. 27b has similar features to the wear plate 600 of Fig. 27a, but has different pattern of varying dimensioned debris slots. A first set of longitudinal debris slots 624 are generally rectangular with rounded corners, similar to the debris slots described and illustrated above, and are located centrally between the lateral sides 626 of the wear plate 620. A second set of peripheral debris slots 628 extend adjacent to the lateral sides 626 of the wear plate 620. Each of the peripheral debris slots 628 has a longitudinal portion 632 extending along a similar direction as the longitudinal debris slots

624, and a lateral portion 636 that deviates from the longitudinal portion 632 and extends along the travel direction dt of the belt. It has been found that, in some cases, debris travels down the lateral sides of the endless belts and gets underneath between the endless belt and the wear plates. The peripheral debris slots 628, and their lateral portions 636 in particular, assist in quickly flushing away this debris to reduce its chances of lingering between the endless belt and the wear plate 600.

[0123] Fig. 28 shows locating features of a wear plate 700 and an edge guide 704 that assist with maintaining the correct alignment of the wear plates 700 while enabling them to expand and contract as a result of fluctuations in the operating temperature. The wear plates 700 have locating slots 708 along their lateral edges. The edge guide 704 is made of 14 gauge stainless steel that has a curved profile, enabling it to be deflected as the wear plates 700 are being positioned. Locating tabs 712 of the edge guide 704 mate with the locating slots 708 of the wear plates 700. The size of the locating tabs 712 and the locating slots 708 are selected to enable the wear plates 700 to expand and contract.

[0124] It will be appreciated that, although embodiments of the disclosure have been described and illustrated in detail, various modifications and changes may be made. While preferred embodiments are described above, some of the features described above can be replaced or even omitted. Still further alternatives and modifications may occur to those skilled in the art. All such alternatives and modifications are believed to be within the scope of the disclosure.

CLAIMS

1. A conveyor system, comprising:

an endless belt mounted in a longitudinal direction through the service line, the endless belt having an upper transport portion adapted to move a wheeled structure
5 through a service line, and a lower return portion;

a support deck positioned below the upper transport portion of the endless belt to support the endless belt, the support deck having a belt contact surface extending along a top of the support deck and in contact with the upper transport portion of the endless belt, the belt contact surface being constructed from a material that is at least partially
10 thermoplastic;

a belt rinsing system including a rinsing system conduit arrangement connectable to a source of rinsing system liquid, and at least one belt rinsing arrangement, wherein each of the at least one belt rinsing arrangement includes

a rinsing system dirt pass-through aperture in the support deck, over which
15 the upper transport portion of the endless belt travels during operation; and

at least one rinsing system outlet from the rinsing system conduit arrangement positioned proximate to the rinsing system dirt pass-through aperture and positioned to eject rinsing system liquid onto the endless belt upstream from a downstream edge of the rinsing system dirt pass-through aperture in order to

capture at least some of the ejected liquid through the rinsing system dirt pass-through aperture.

2. A conveyor system as claimed in claim 1, wherein the material is at least partially polyethylene.
- 5 3. A conveyor system as claimed in claim 2, wherein the material is at least partially ultra-high-molecular-weight polyethylene.
4. A conveyor system as claimed in claim 2, wherein the material is at least partially high-density polyethylene.
5. A conveyor system as claimed in claim 1, wherein the belt contact surface is
10 formed of a set of wear plates formed from the material.
6. A conveyor system as claimed in claim 5, wherein an expansion gap is provided between the wear plates to allow for thermal expansion of the wear plates.
7. A conveyor system as claimed in claim 6, wherein the wear plates have mating features inhibiting lateral shifting of the wear plates.

8. A conveyor system as claimed in claim 7, wherein each wear plate has at least one finger that extends longitudinally from a lateral end of one of the leading edge and the trailing edge, each of the at least one finger being received within a corresponding longitudinally extending recess on the other of the leading edge and the trailing edge of
5 an adjacent one of the wear plates.

9. A wear plate for a conveyor system, the conveyor system having an endless belt mounted in a longitudinal direction through the service line, the endless belt having an upper transport portion adapted to move a wheeled structure through a service line, and a lower return portion, a support deck positioned below the upper transport portion of the
10 endless belt to support the endless belt, a belt rinsing system including a rinsing system conduit arrangement connectable to a source of rinsing system liquid, and at least one belt rinsing arrangement, wherein each of the at least one belt rinsing arrangement includes a rinsing system dirt pass-through aperture in the support deck, over which the upper transport portion of the endless belt travels during operation, and at least one
15 rinsing system outlet from the rinsing system conduit arrangement positioned proximate to the rinsing system dirt pass-through aperture and positioned to eject rinsing system liquid onto the endless belt upstream from a downstream edge of the rinsing system dirt pass-through aperture in order to capture at least some of the ejected liquid through the rinsing system dirt pass-through aperture, the wear plate being dimensioned to extend
20 along a top of the support deck and contact the upper transport portion of the endless

belt, the wear plate having a corresponding rinsing system dirt pass-through aperture and being constructed from a material that is at least partially thermoplastic.

10. A conveyor system, comprising:

an endless belt mounted in a longitudinal direction through the service line, the
5 endless belt having an upper transport portion adapted to move a wheeled structure through a service line, and a lower return portion, the endless belt being constructed from a first material having a first hardness;

a support deck positioned below the upper transport portion of the endless belt to support the endless belt, the support deck having a belt contact surface extending along
10 a top of the support deck and in contact with the upper transport portion of the endless belt, the belt contact surface being constructed from a second material that has a second hardness that is lesser than the first hardness;

a belt rinsing system including a rinsing system conduit arrangement connectable to a source of rinsing system liquid, and at least one belt rinsing arrangement, wherein
15 each of the at least one belt rinsing arrangement includes

a rinsing system dirt pass-through aperture in the support deck, over which the upper transport portion of the endless belt travels during operation; and

at least one rinsing system outlet from the rinsing system conduit arrangement positioned proximate to the rinsing system dirt pass-through aperture
20 and positioned to eject rinsing system liquid onto the endless belt upstream from

a downstream edge of the rinsing system dirt pass-through aperture in order to capture at least some of the ejected liquid through the rinsing system dirt pass-through aperture.

11. A conveyor system as claimed in claim 10, wherein the second material is at least
5 partially thermoplastic.
12. A conveyor system as claimed in claim 11, wherein the material is at least partially polyethylene.
13. A conveyor system as claimed in claim 12, wherein the material is at least partially ultra-high-molecular-weight polyethylene.
- 10 14. A conveyor system as claimed in claim 12, wherein the material is at least partially high-density polyethylene.
15. A conveyor system as claimed in claim 10, wherein the belt contact surface is formed of a set of wear plates formed from the material.
16. A conveyor system as claimed in claim 15, wherein an expansion gap is provided
15 between the wear plates to allow for thermal expansion of the wear plates.

17. A conveyor system as claimed in claim 16, wherein the wear plates have mating features inhibiting lateral shifting of the wear plates.

18. A conveyor system as claimed in claim 17, wherein each wear plate has at least one finger that extends longitudinally from a lateral end of one of the leading edge and the trailing edge, each of the at least one finger being received within a corresponding
5 longitudinally extending recess on the other of the leading edge and the trailing edge of an adjacent one of the wear plates.

19. A wear plate for a conveyor system, the conveyor system having an endless belt mounted in a longitudinal direction through the service line, the endless belt having an
10 upper transport portion adapted to move a wheeled structure through a service line, and a lower return portion, the endless belt being constructed from a first material having a first hardness, and a support deck positioned below the upper transport portion of the endless belt to support the endless belt, a belt rinsing system including a rinsing system conduit arrangement connectable to a source of rinsing system liquid, and at least one
15 belt rinsing arrangement, wherein each of the at least one belt rinsing arrangement includes a rinsing system dirt pass-through aperture in the support deck, over which the upper transport portion of the endless belt travels during operation, and at least one rinsing system outlet from the rinsing system conduit arrangement positioned proximate to the rinsing system dirt pass-through aperture and positioned to eject rinsing system

liquid onto the endless belt upstream from a downstream edge of the rinsing system dirt pass-through aperture in order to capture at least some of the ejected liquid through the rinsing system dirt pass-through aperture, the wear plate being dimensioned to extend along a top of the support deck and contact the upper transport portion of the endless
5 belt, the wear plate having a corresponding rinsing system dirt pass-through aperture and being constructed from a second material that has a second hardness that is lesser than the first hardness.

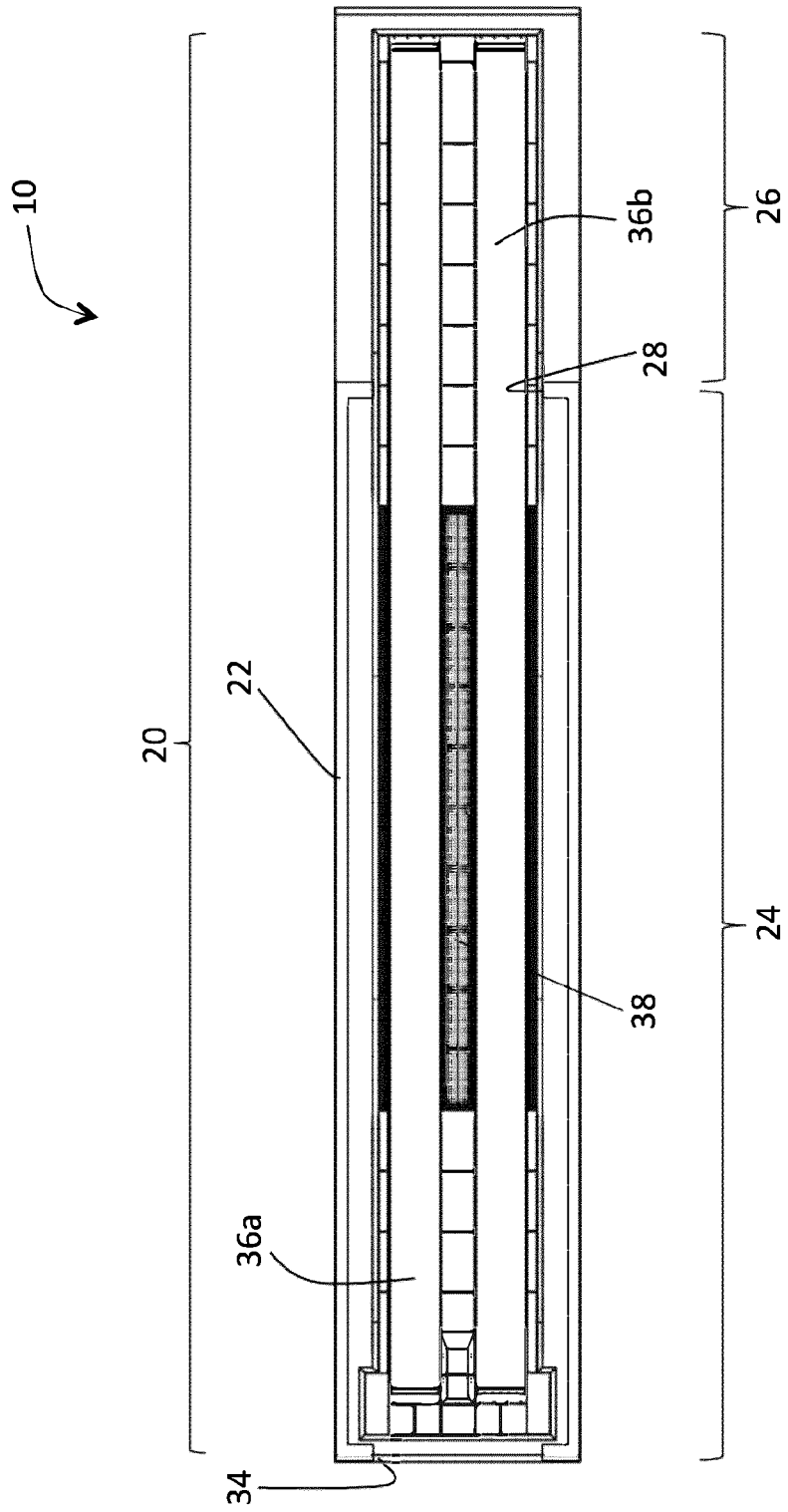

Fig. 1

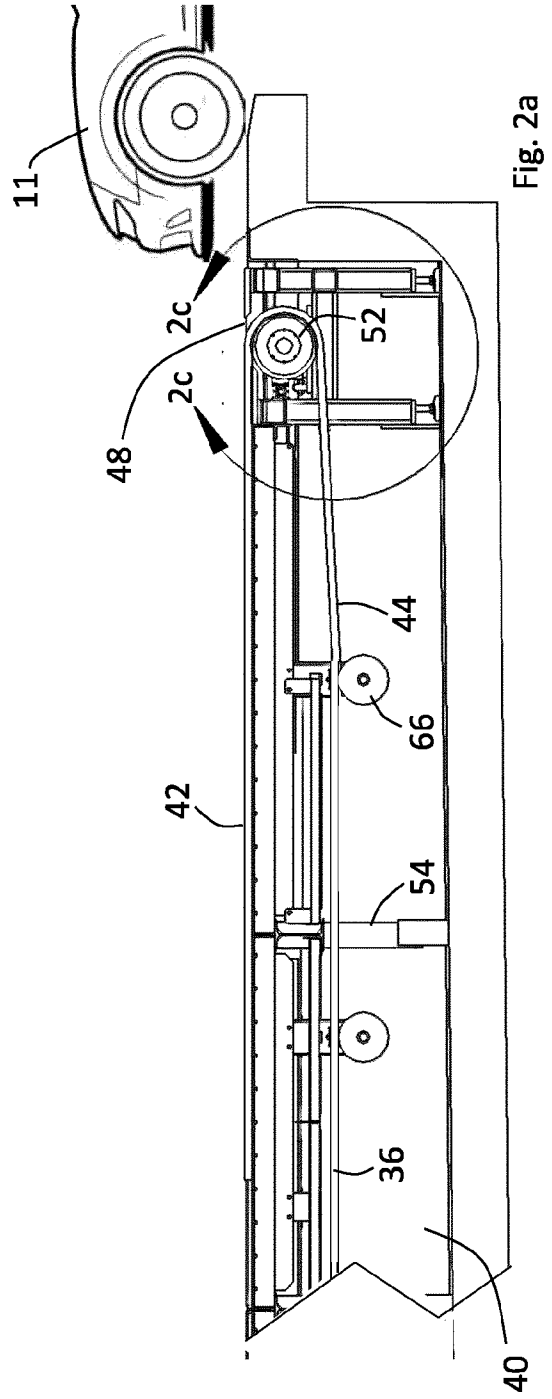
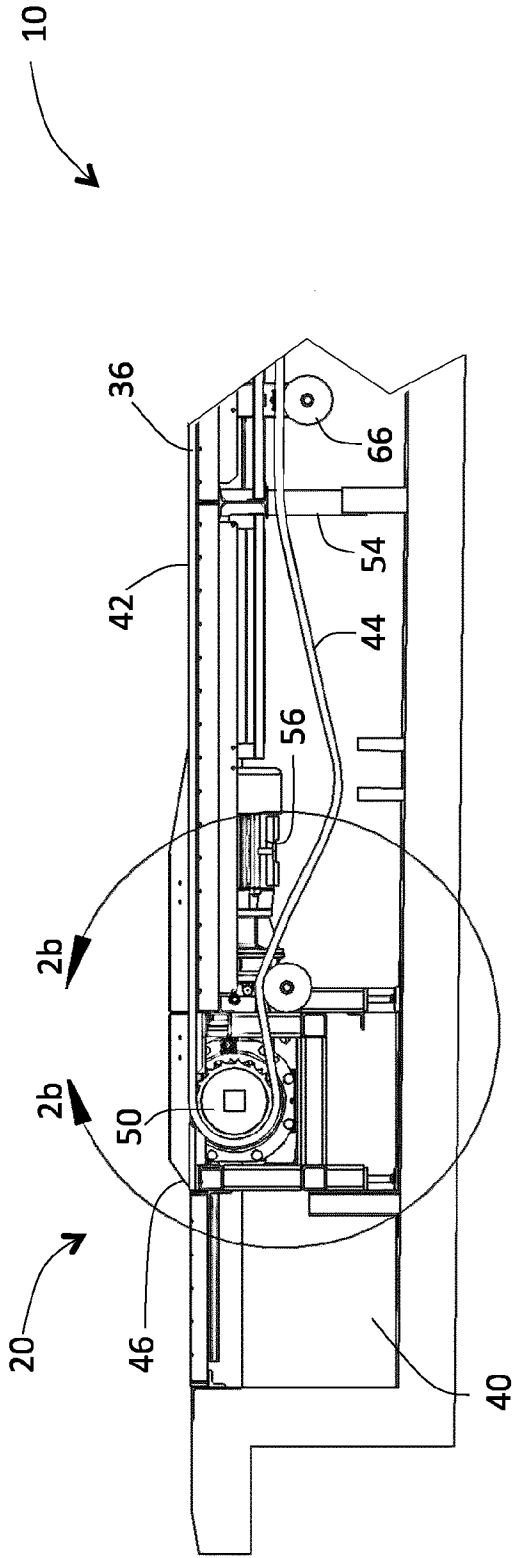

Fig. 2a

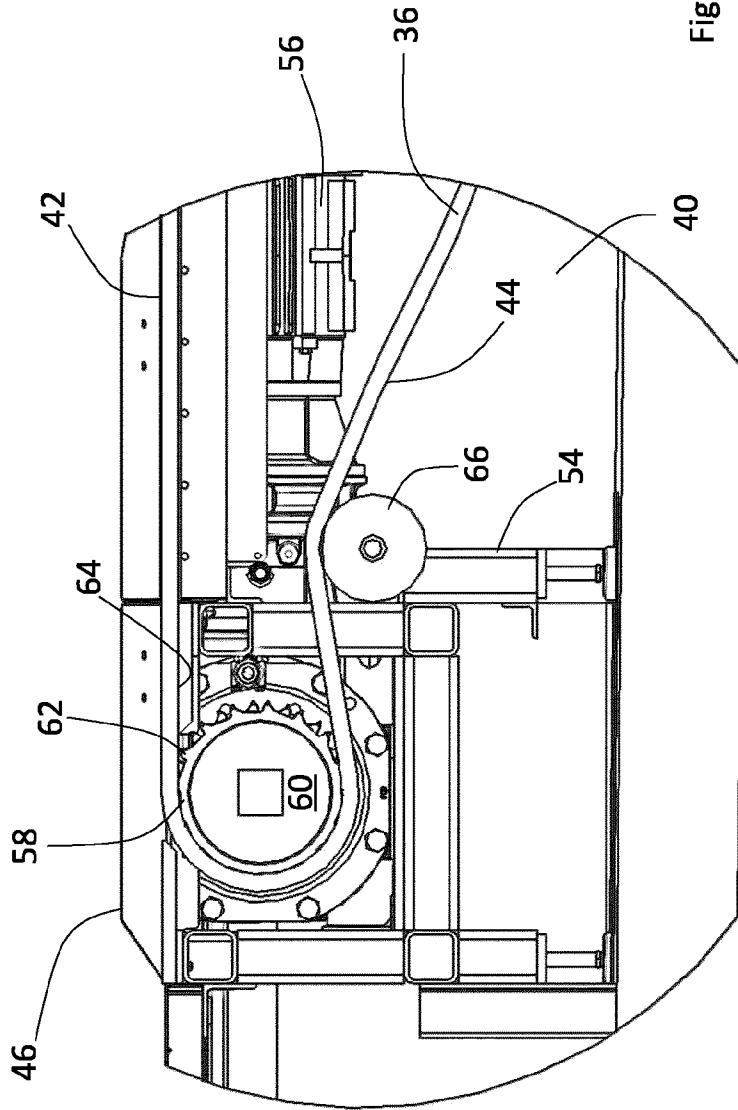

Fig. 2b

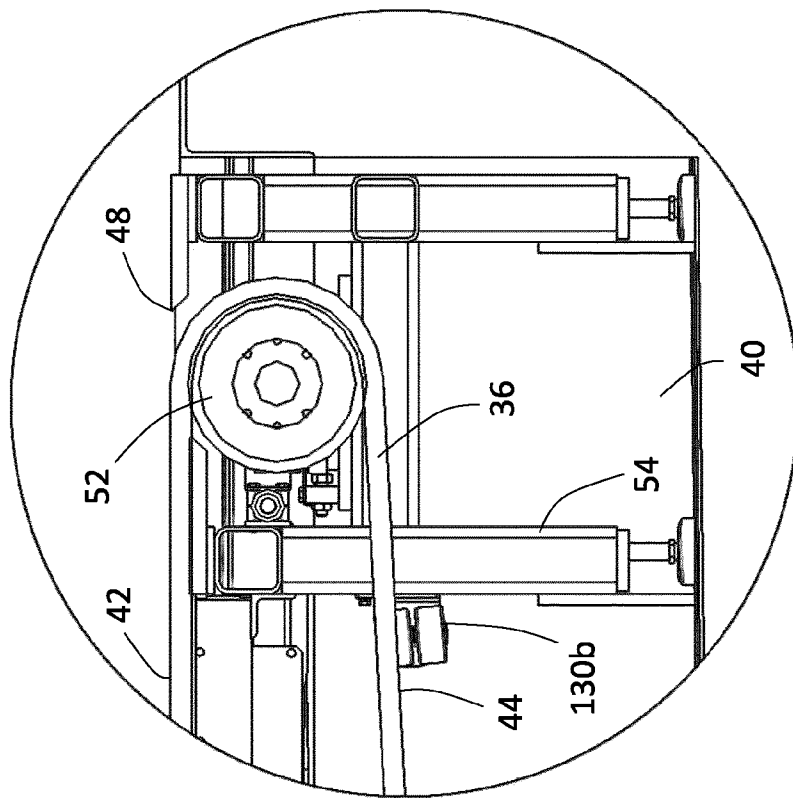
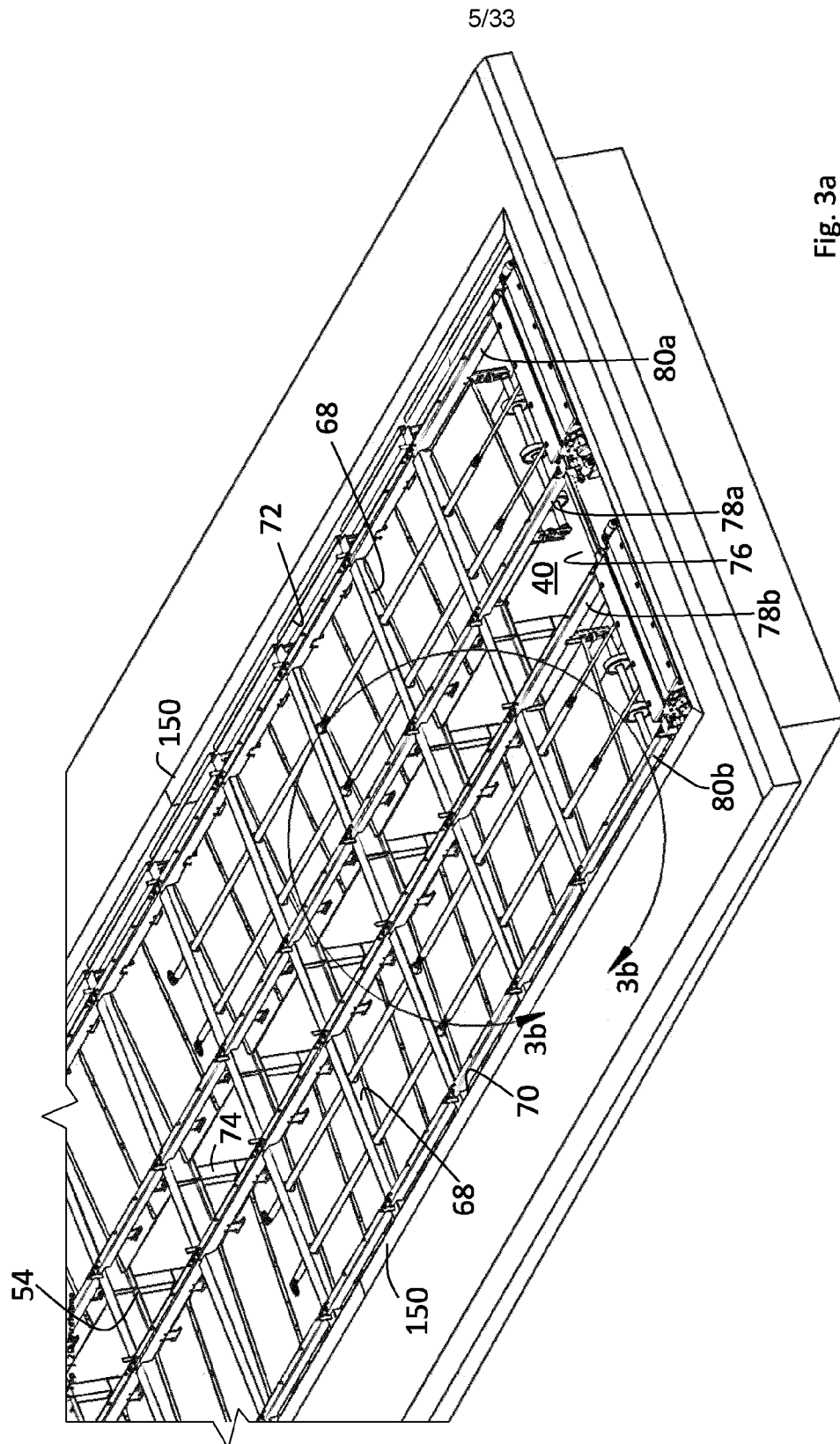

Fig. 2c



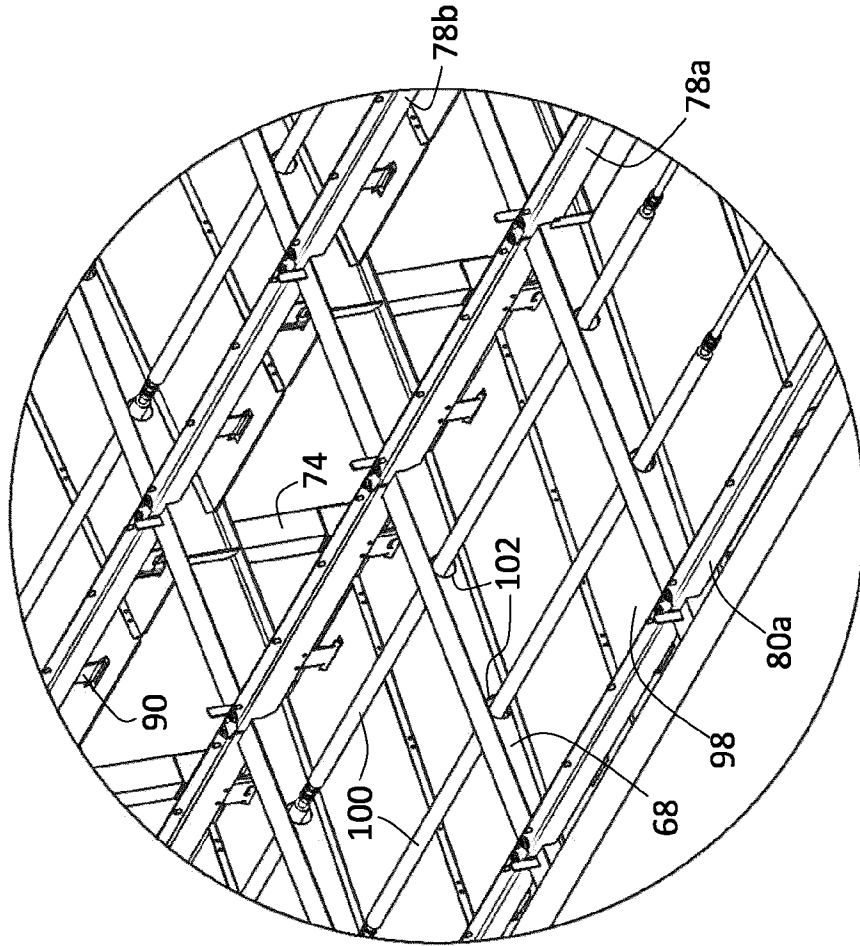
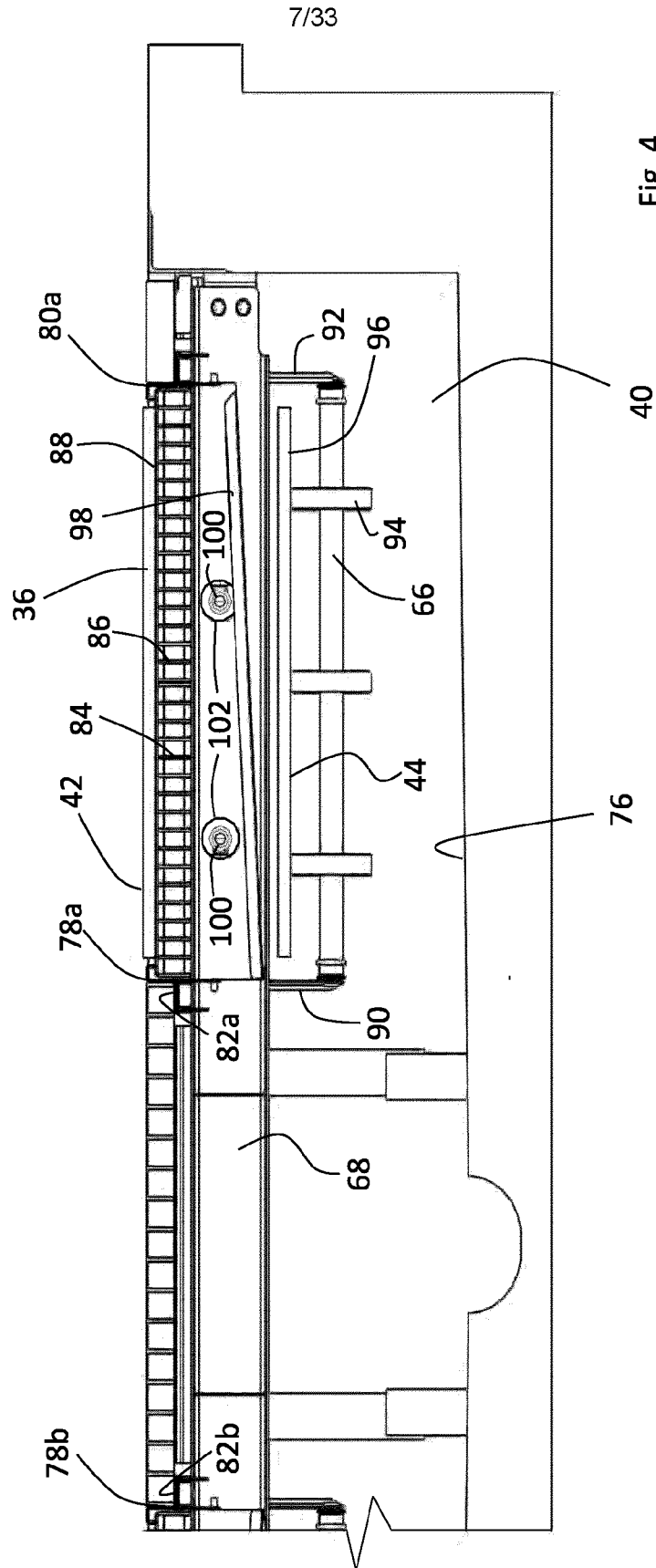

Fig. 3b



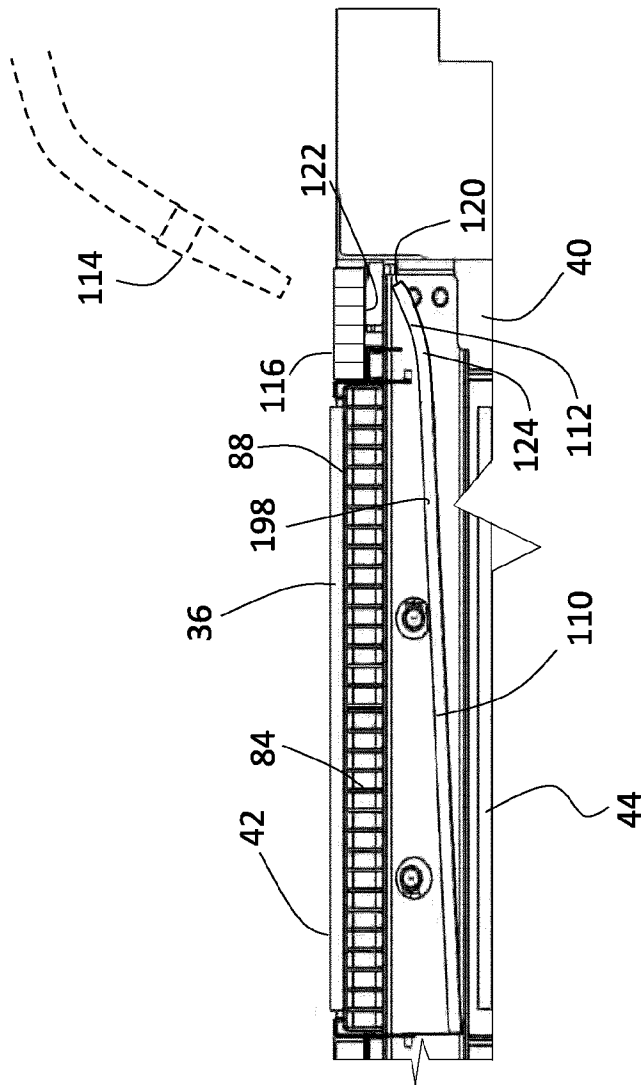

Fig. 5

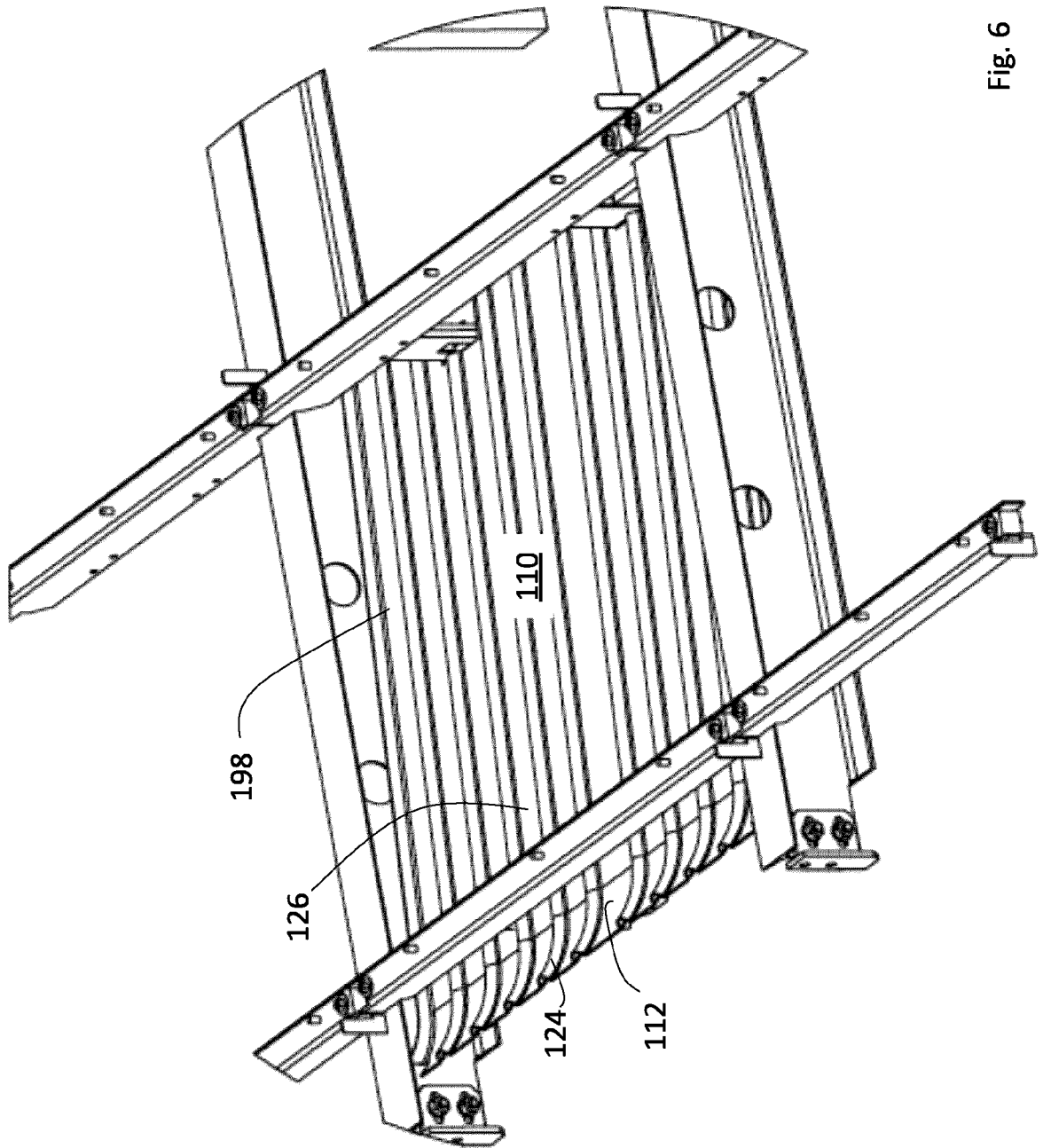

Fig. 6

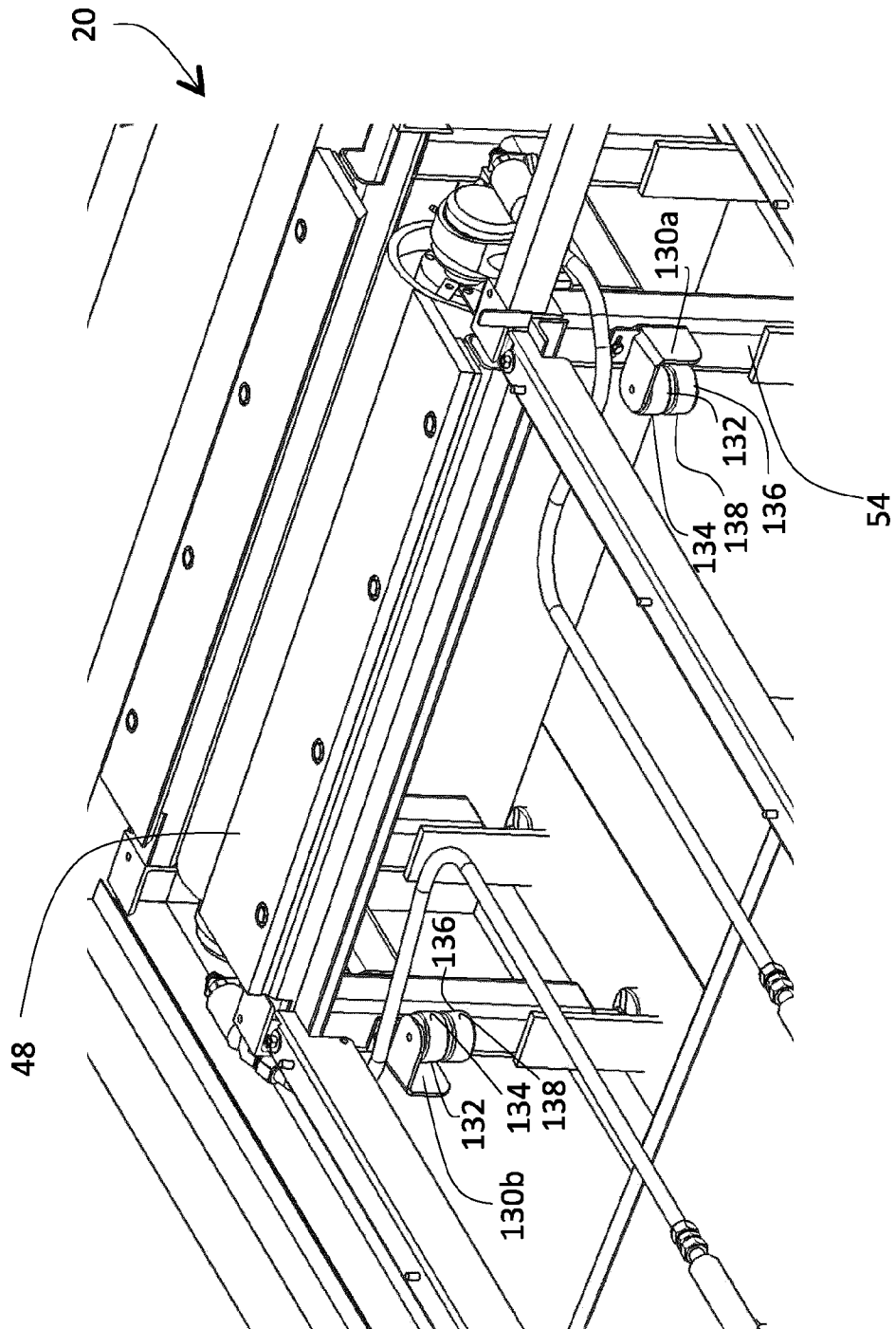

Fig. 7

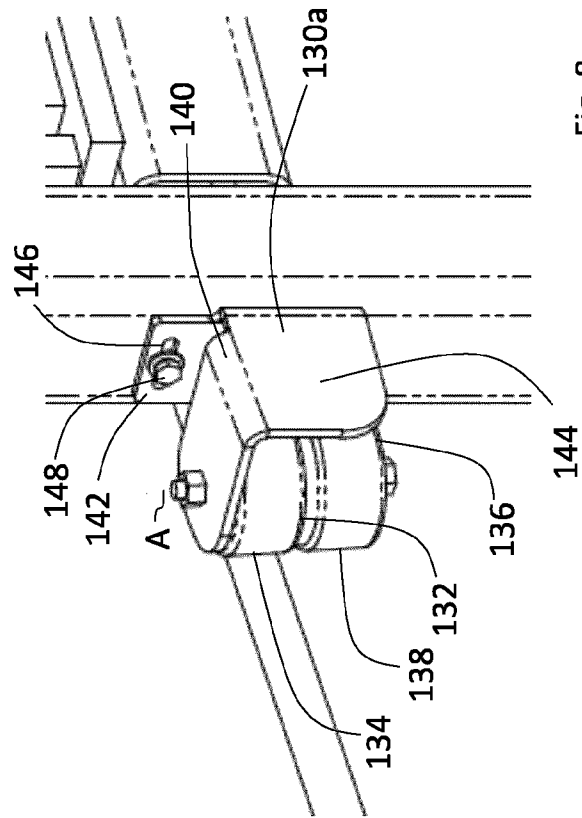

Fig. 8

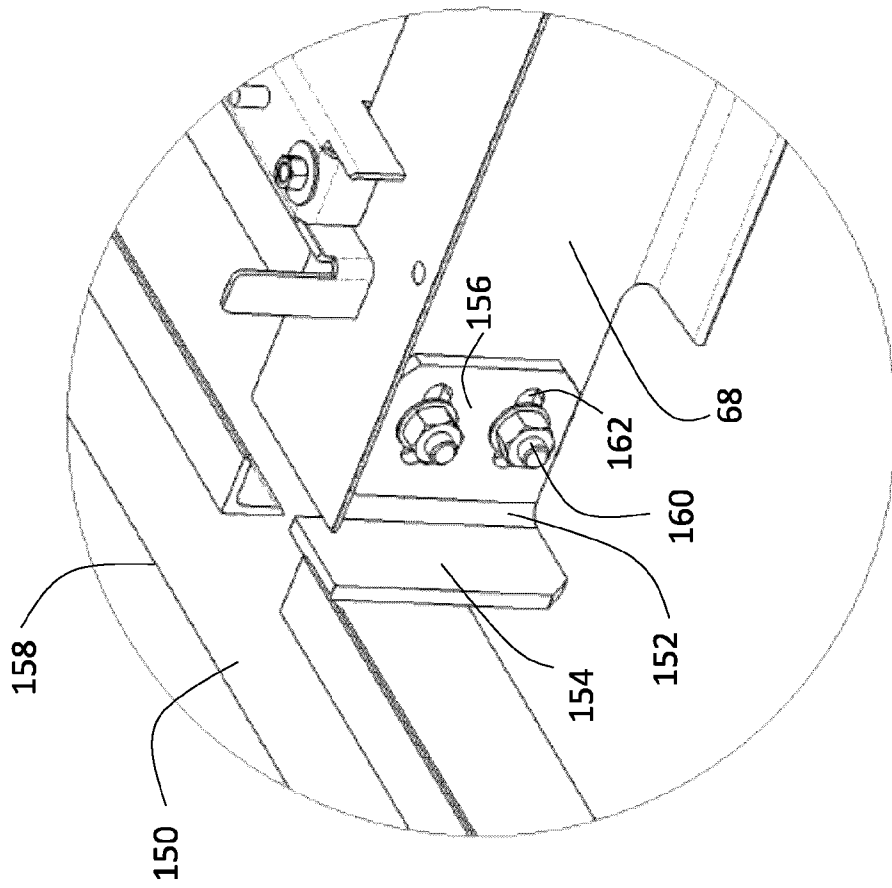
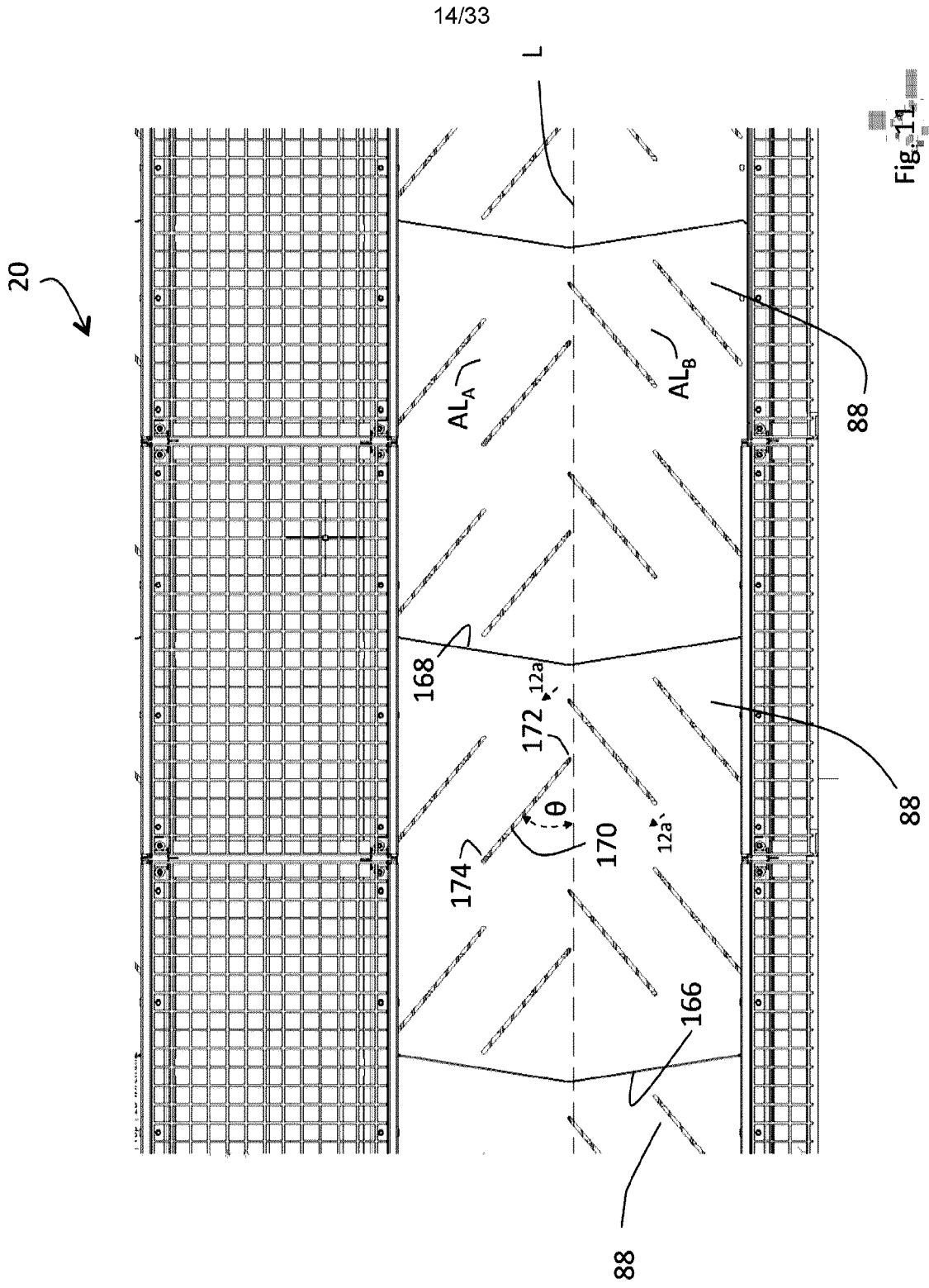
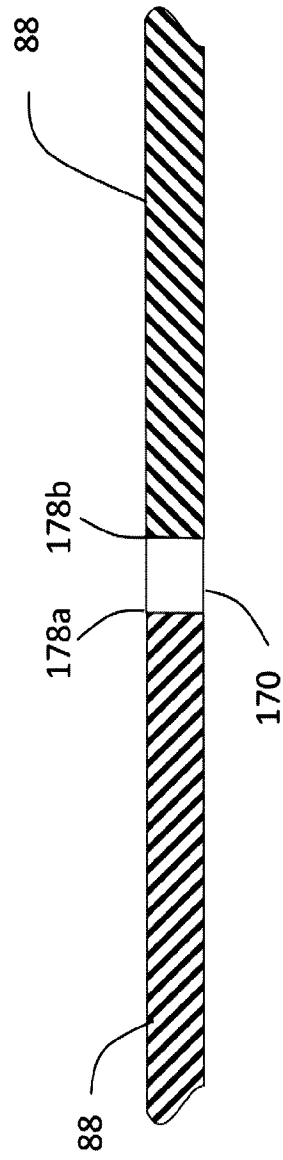
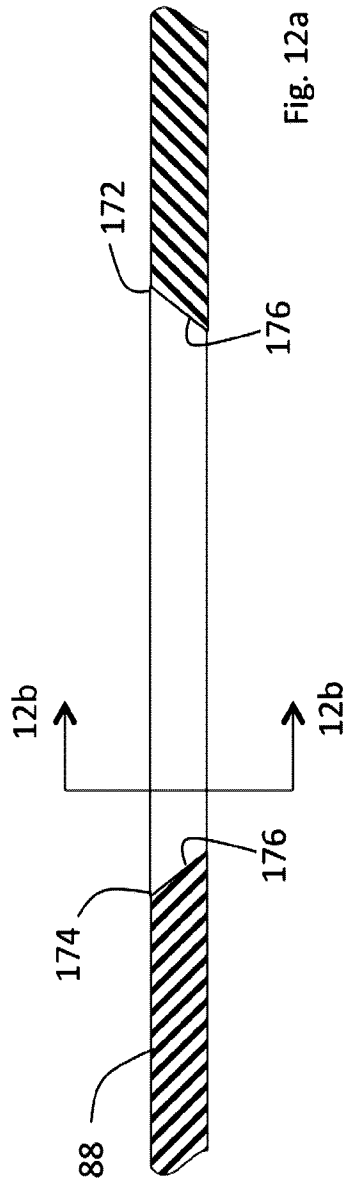

Fig. 9





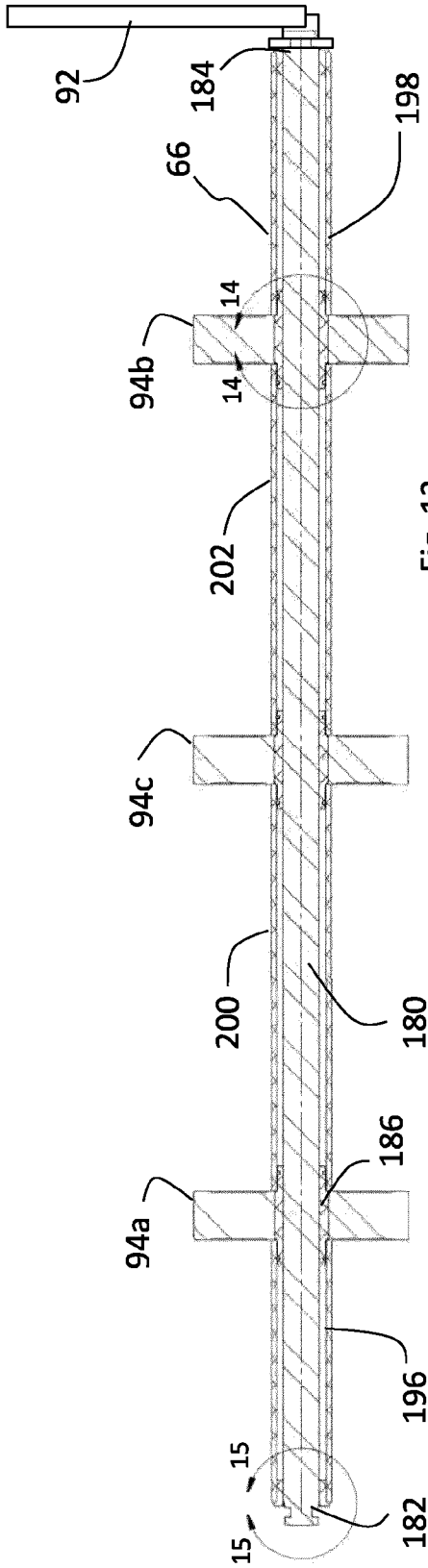

Fig. 13

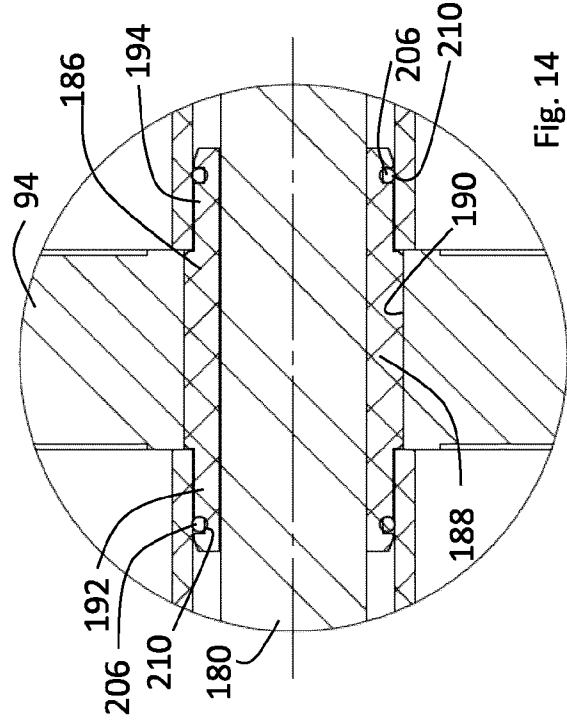

Fig. 14

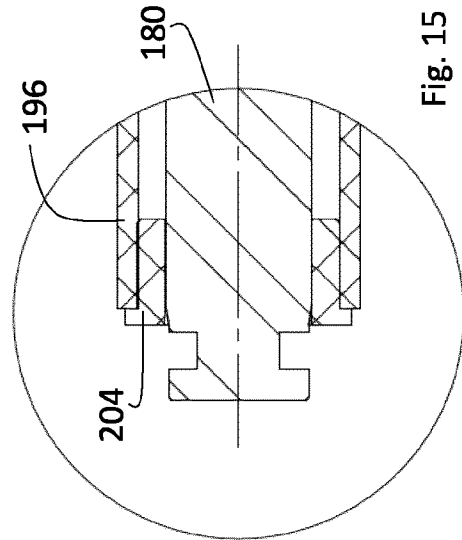

Fig. 15

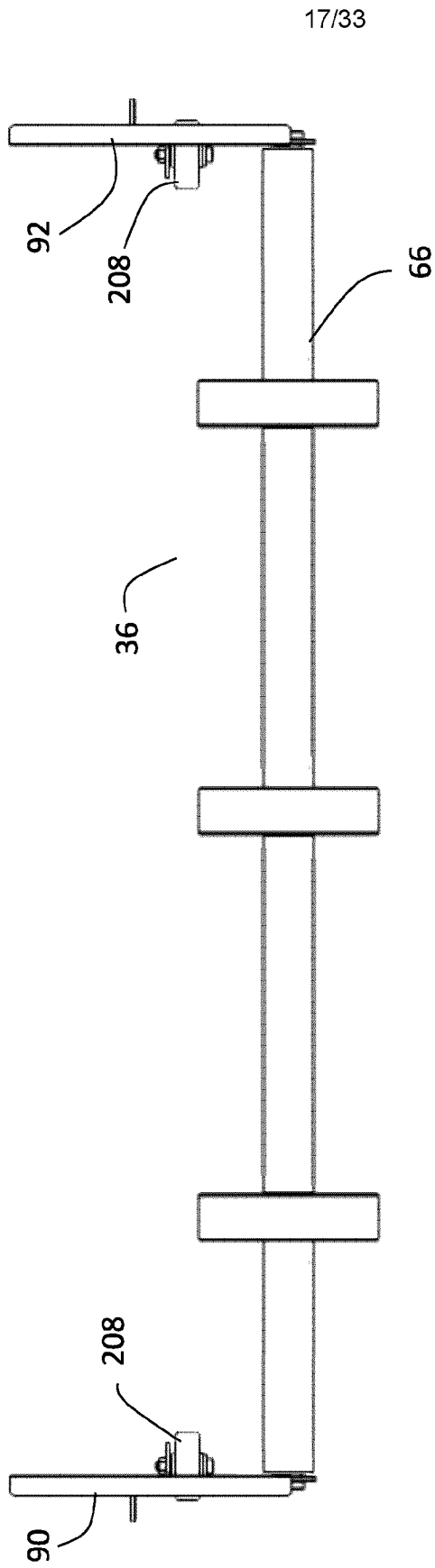

Fig. 16

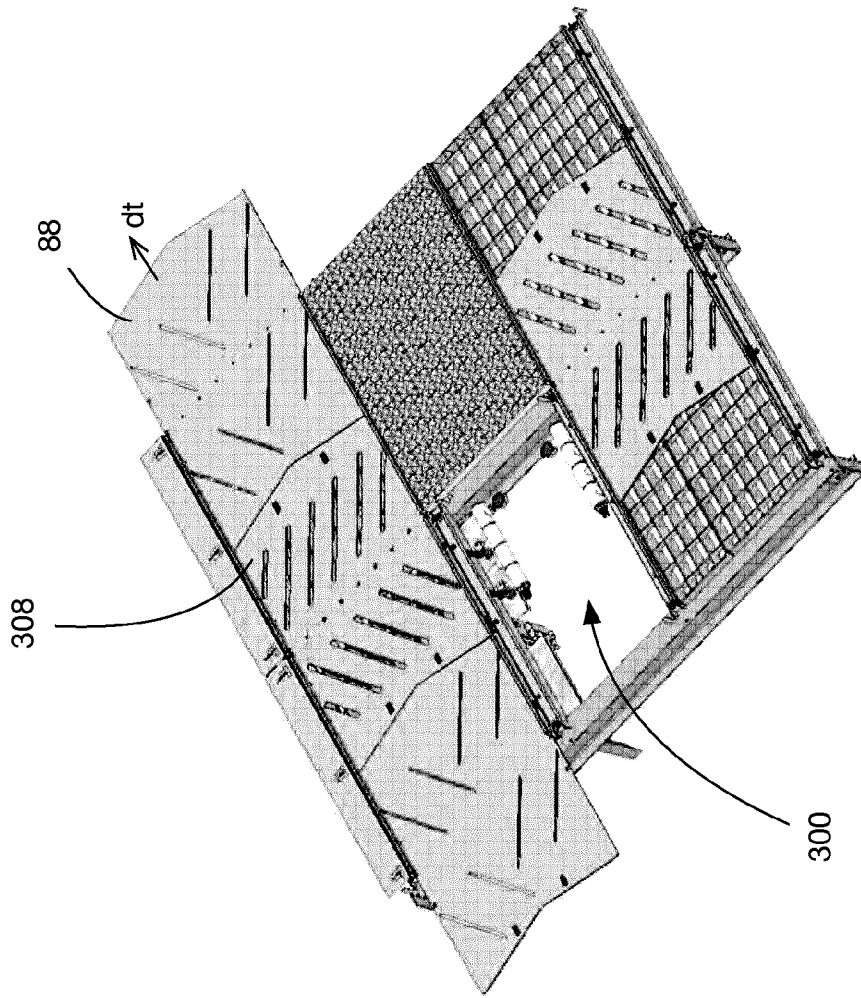

FIG. 17a

19/33

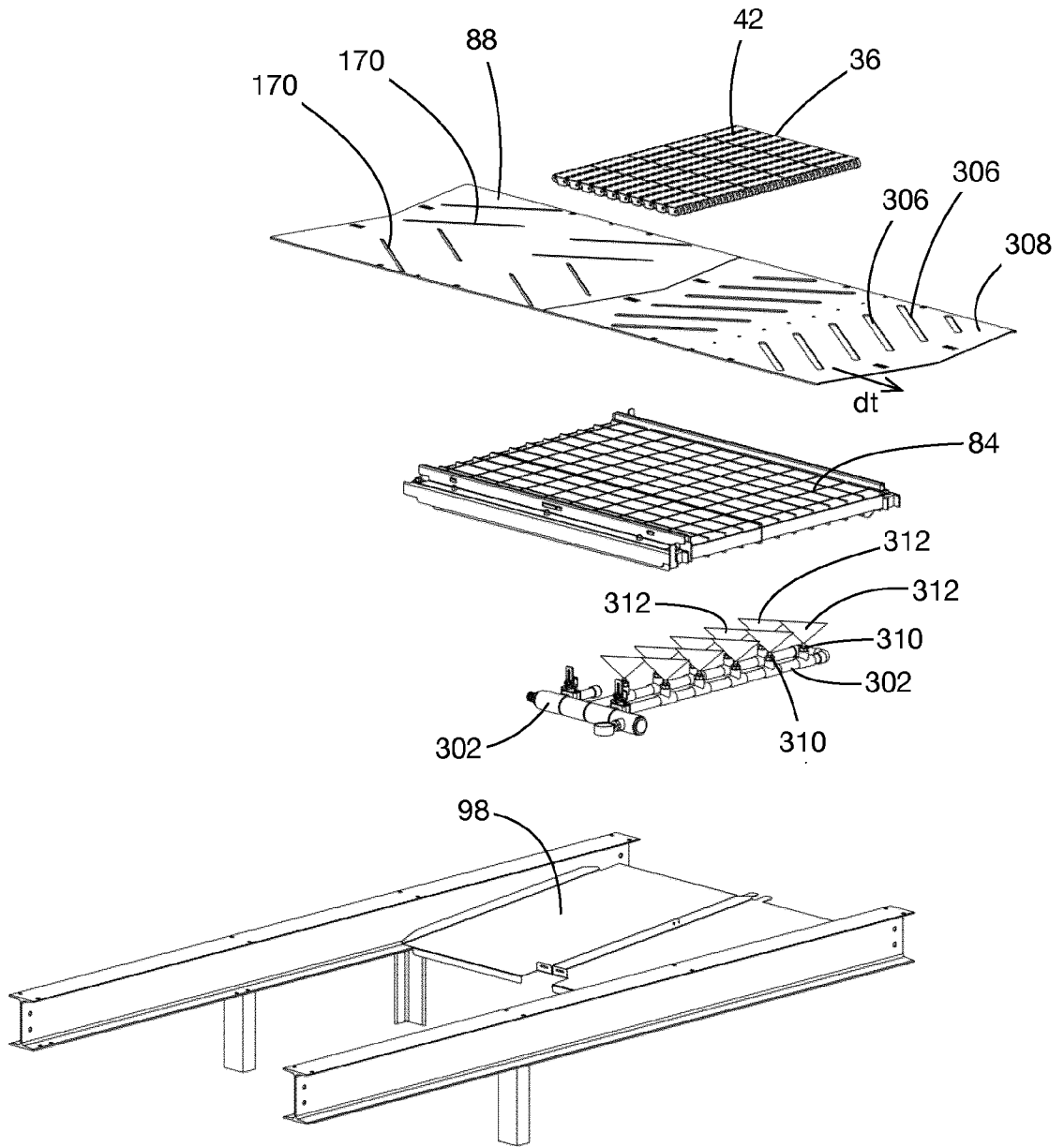

FIG. 17b

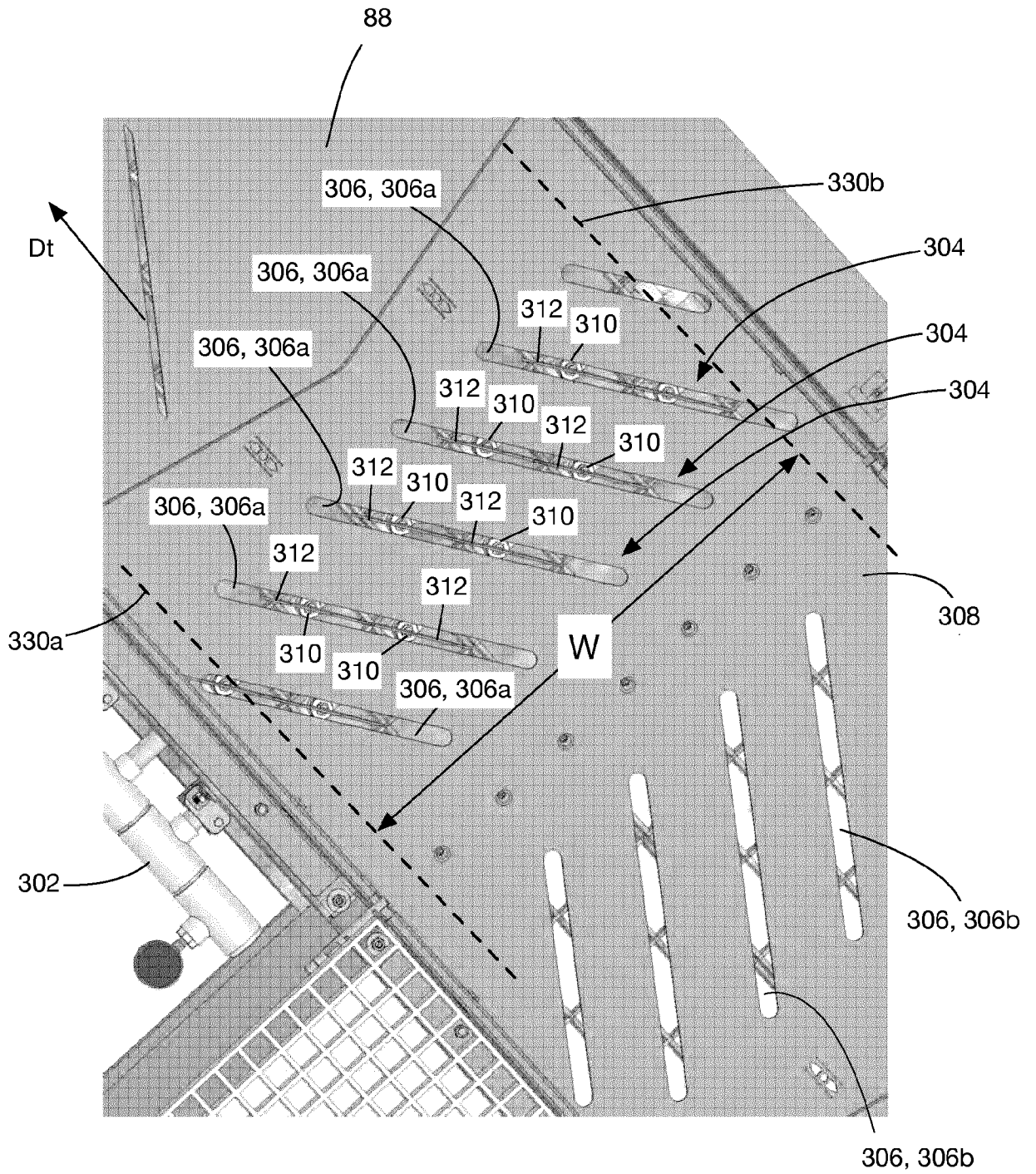

FIG. 18

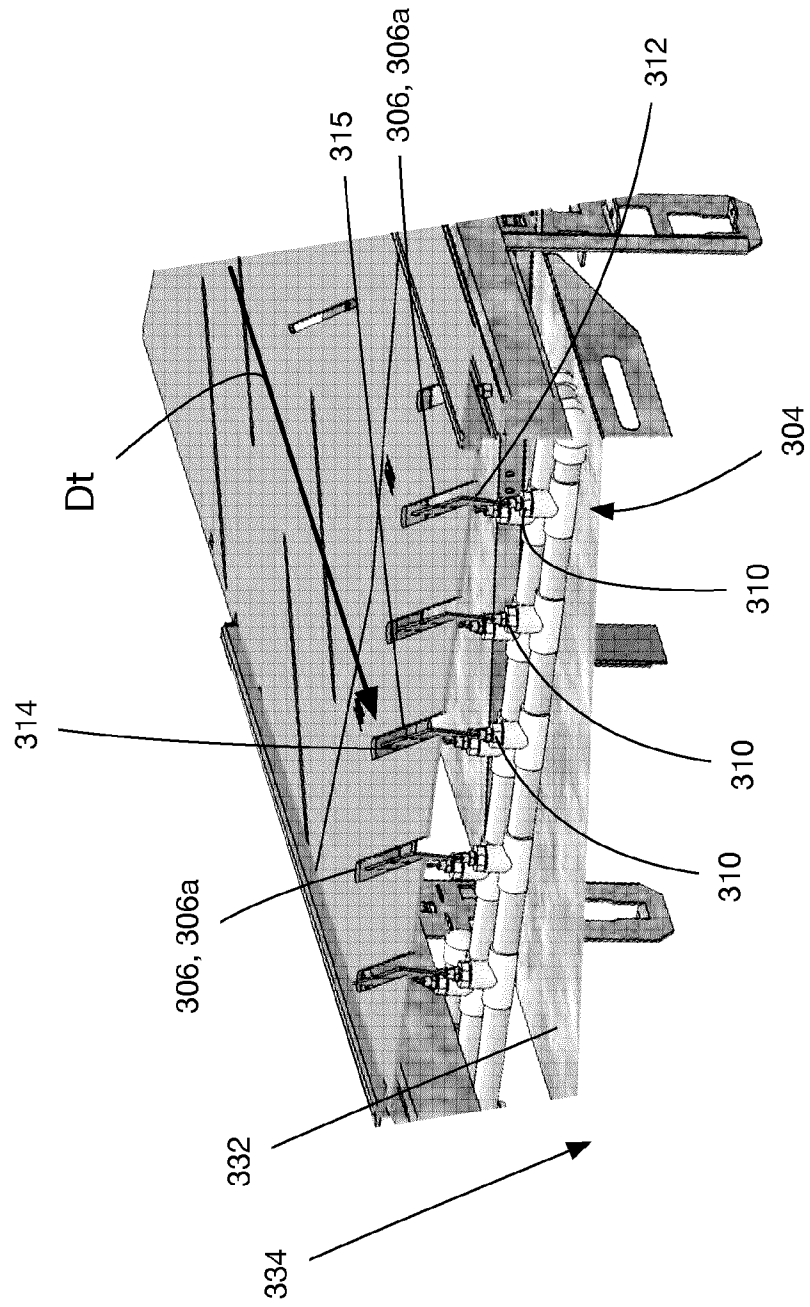

FIG. 19

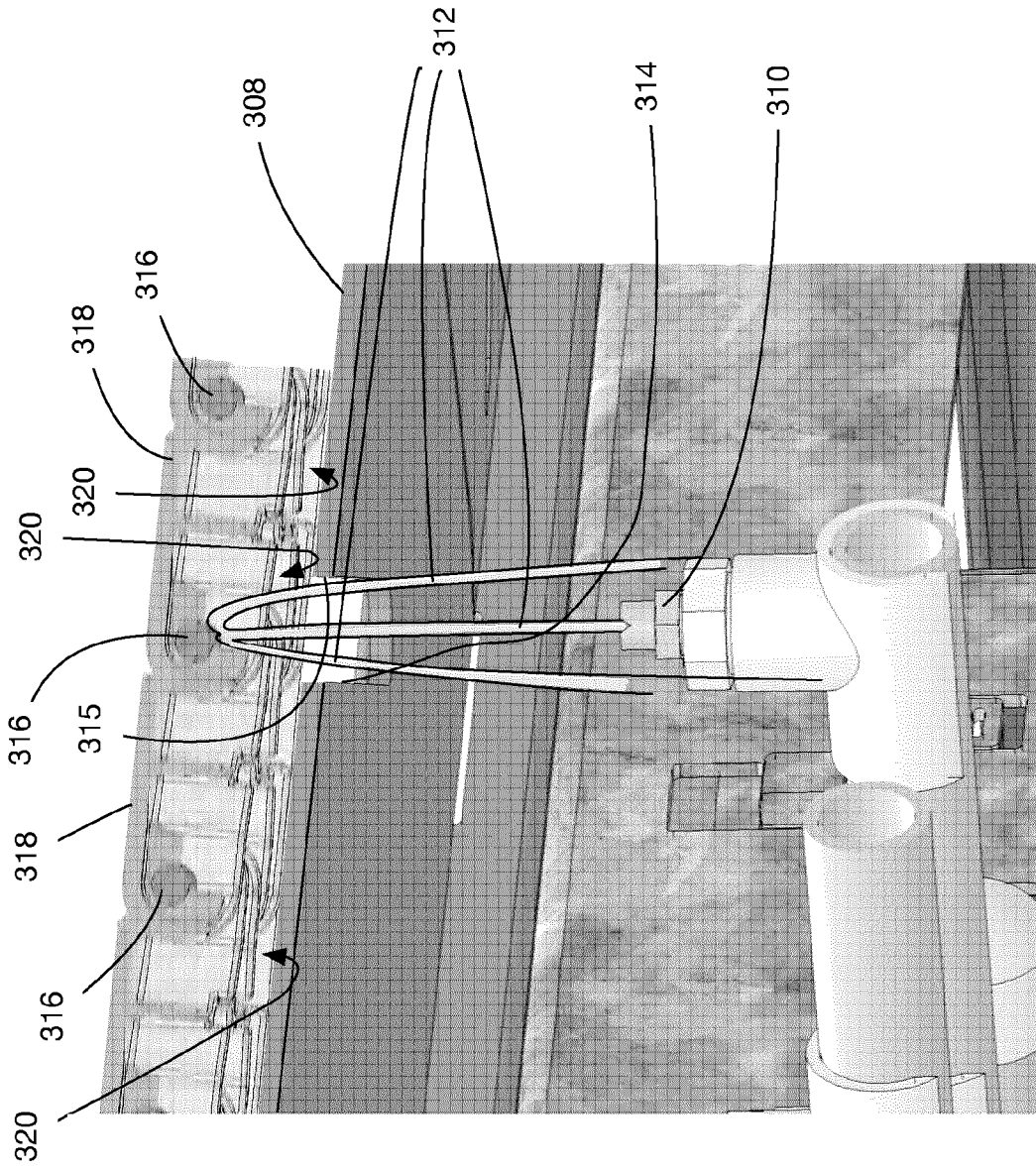

FIG. 20

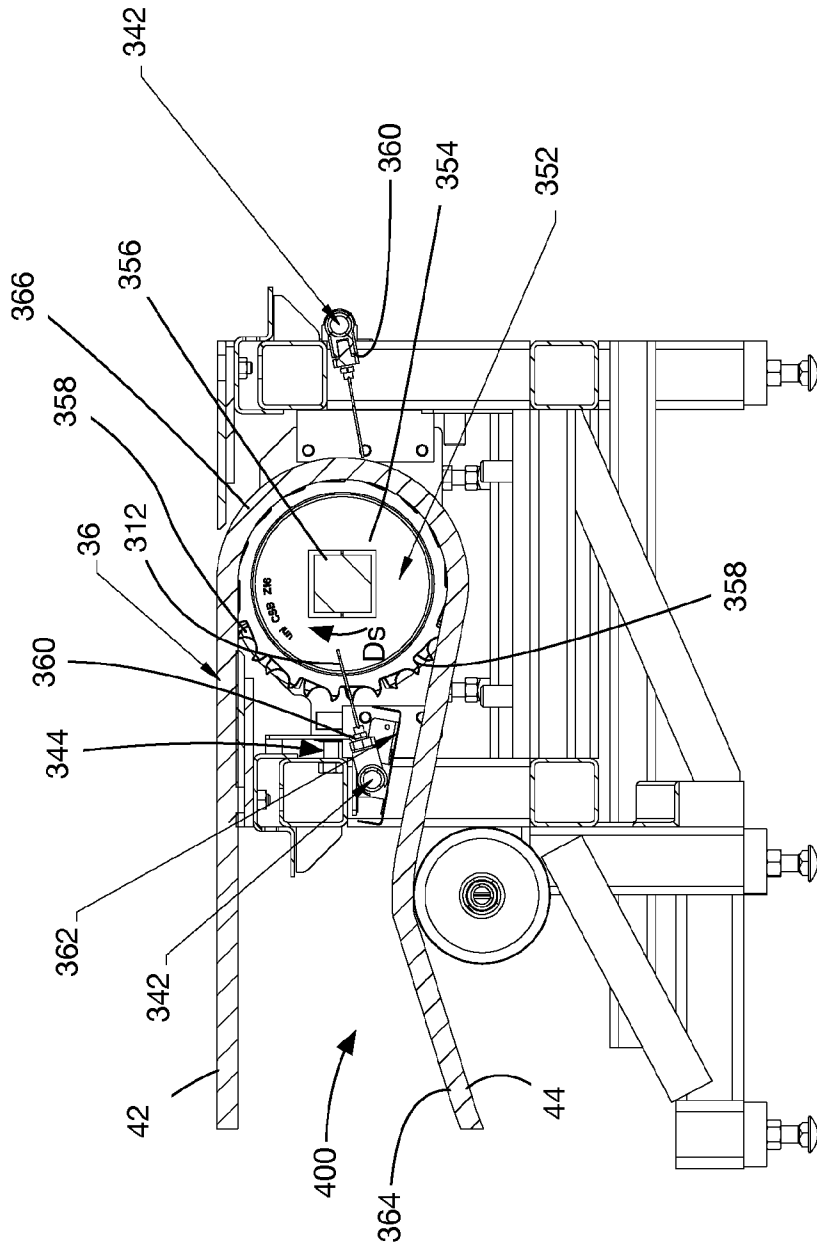

FIG. 21

25/33

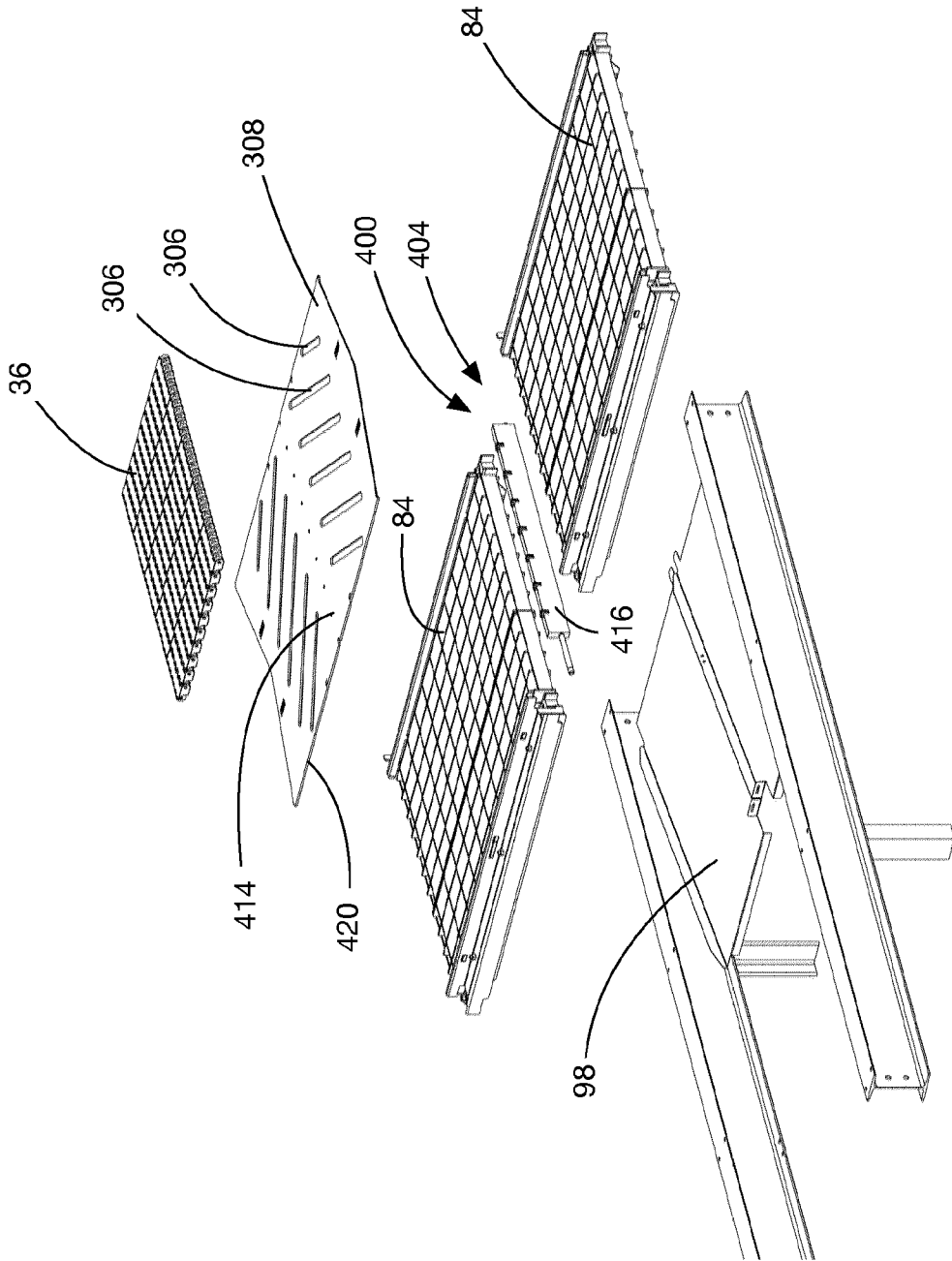

FIG. 23

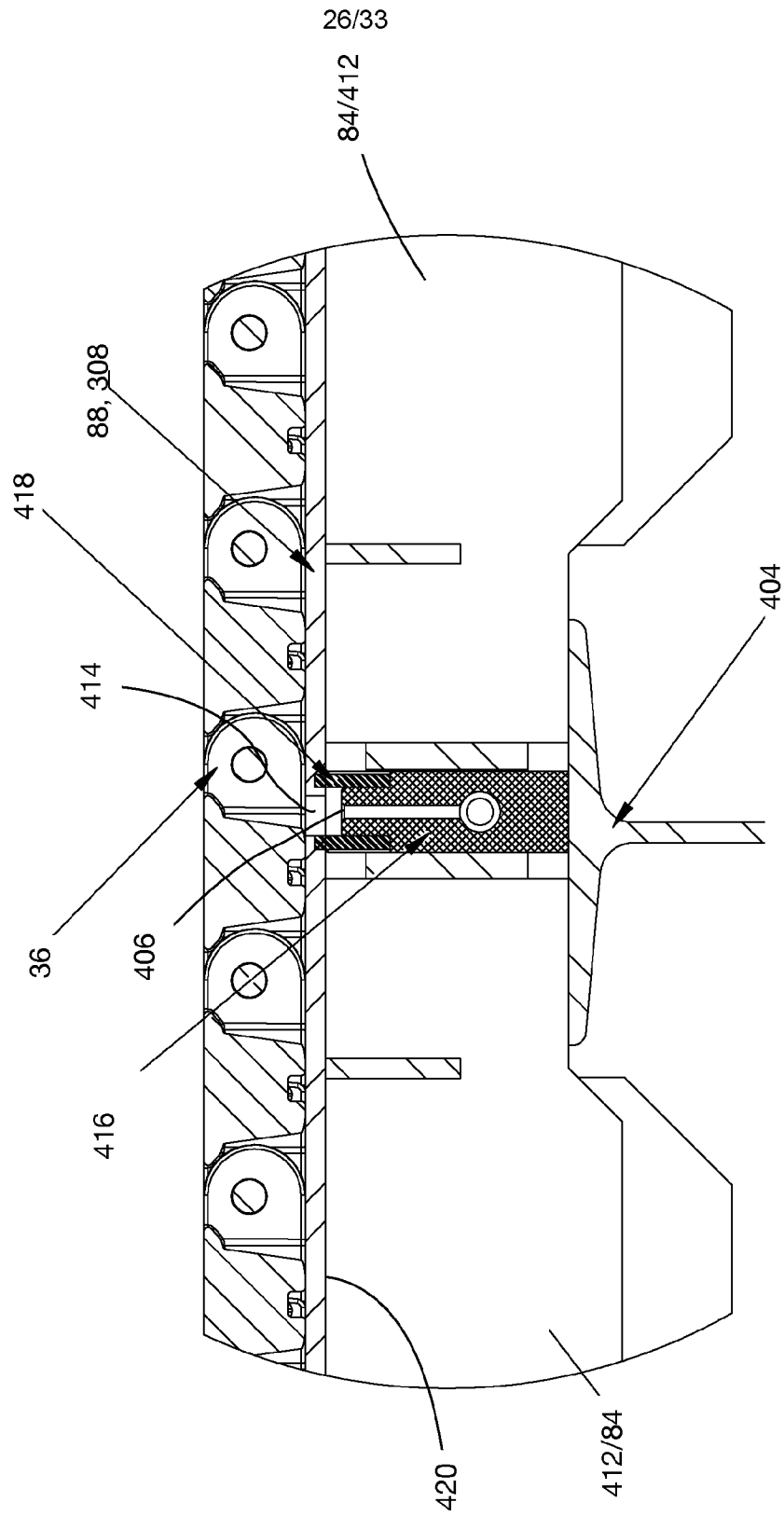

FIG. 24

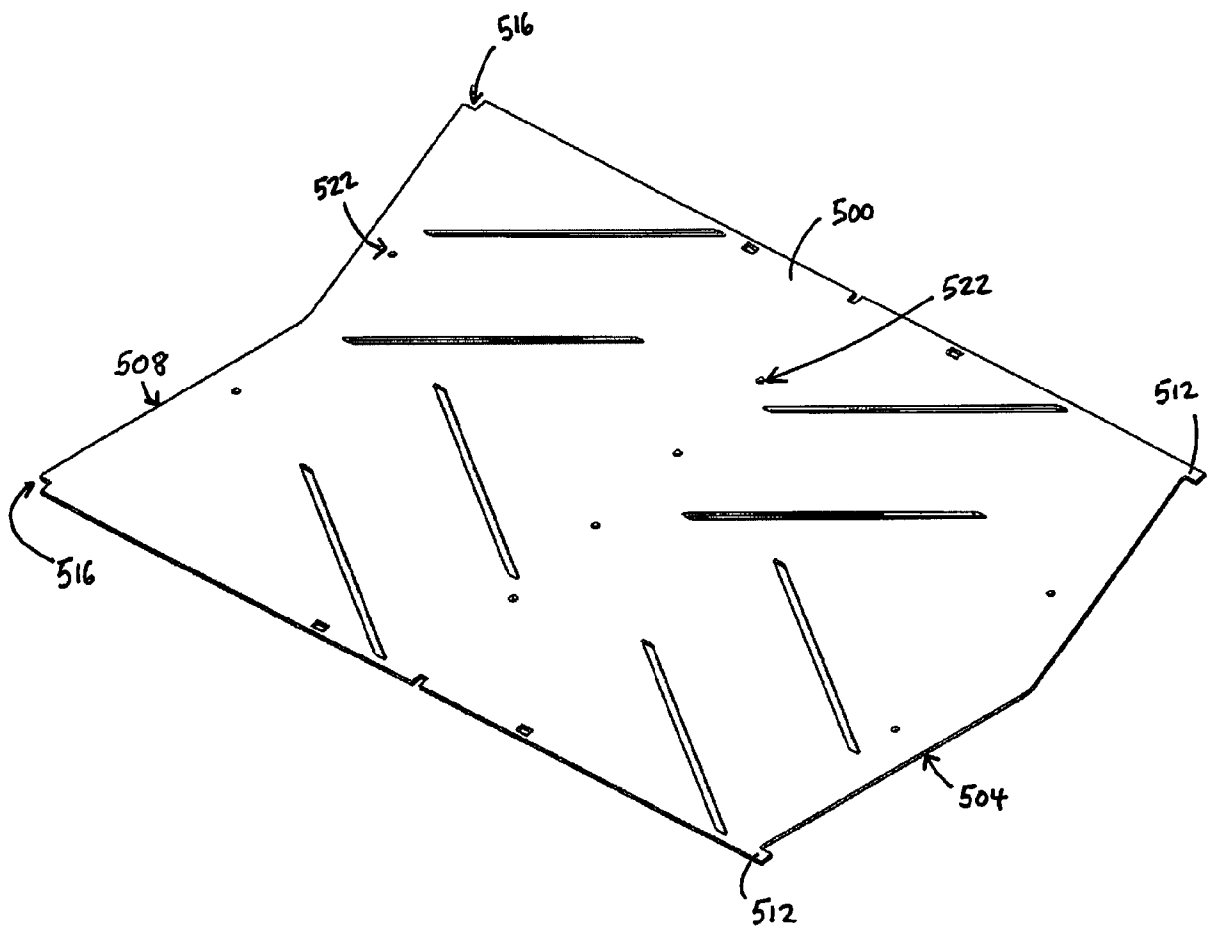

Fig. 26a

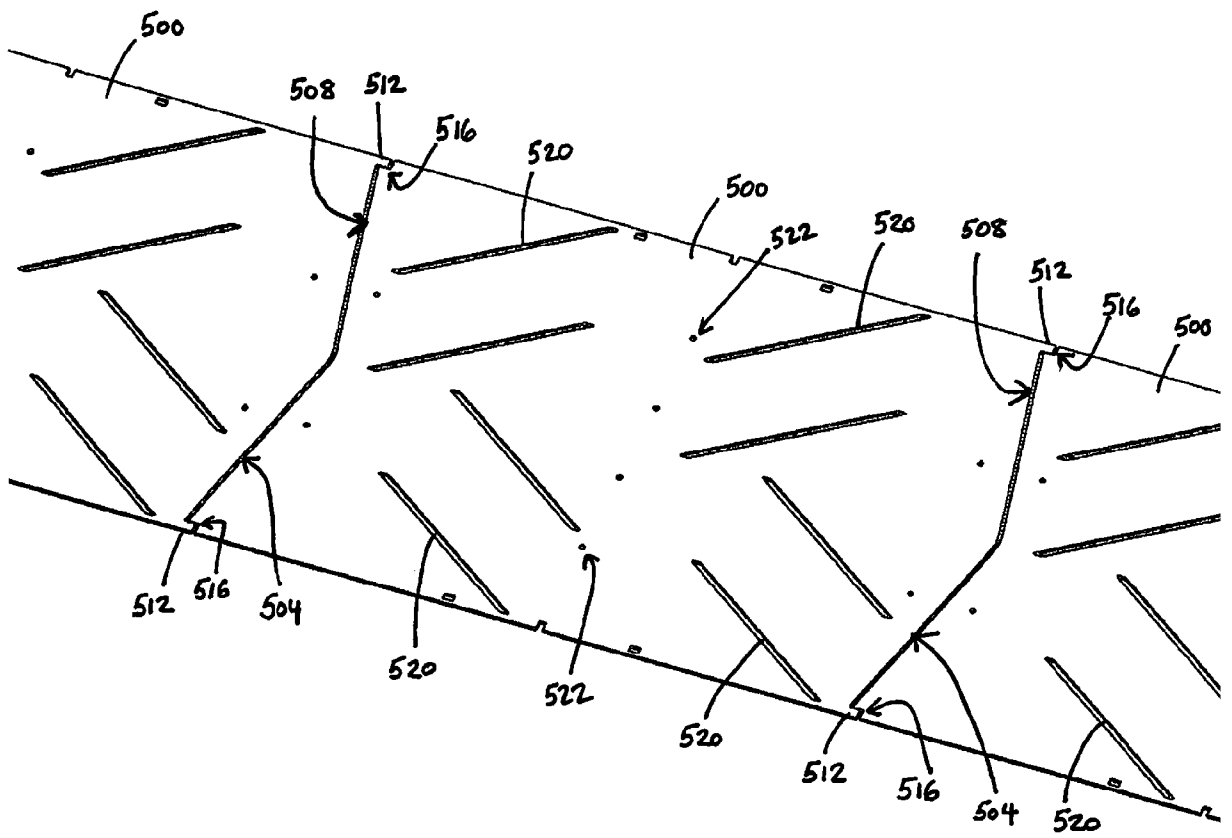

Fig. 26b

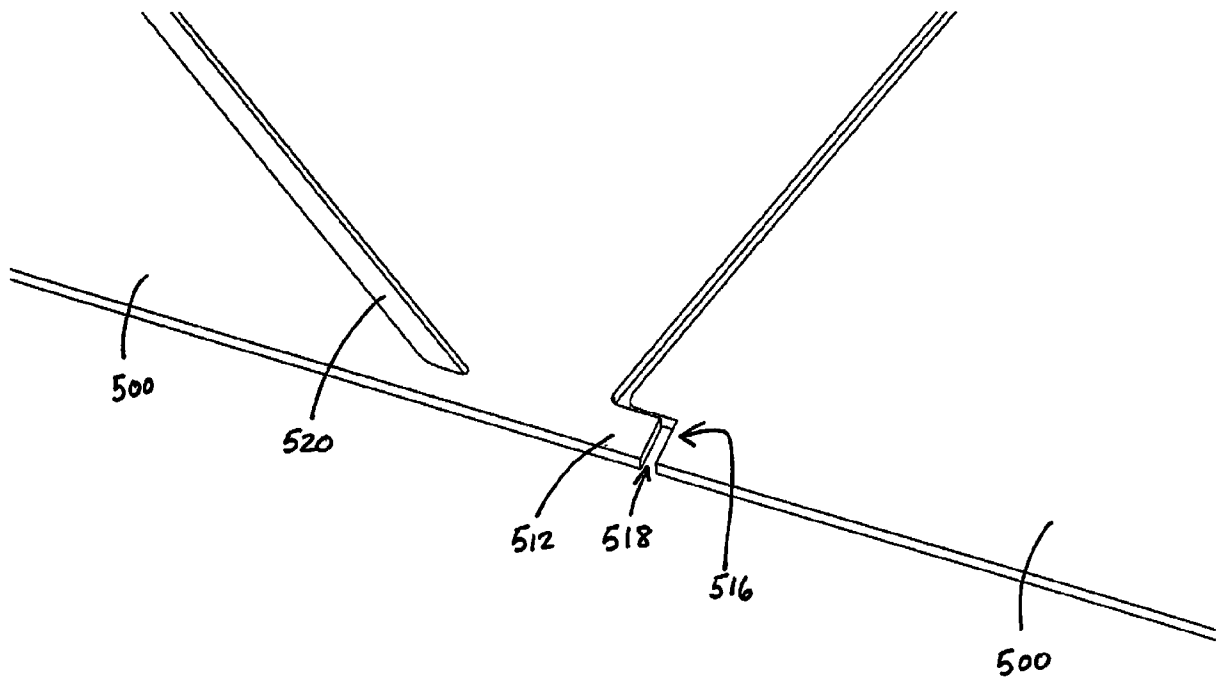

Fig. 26c

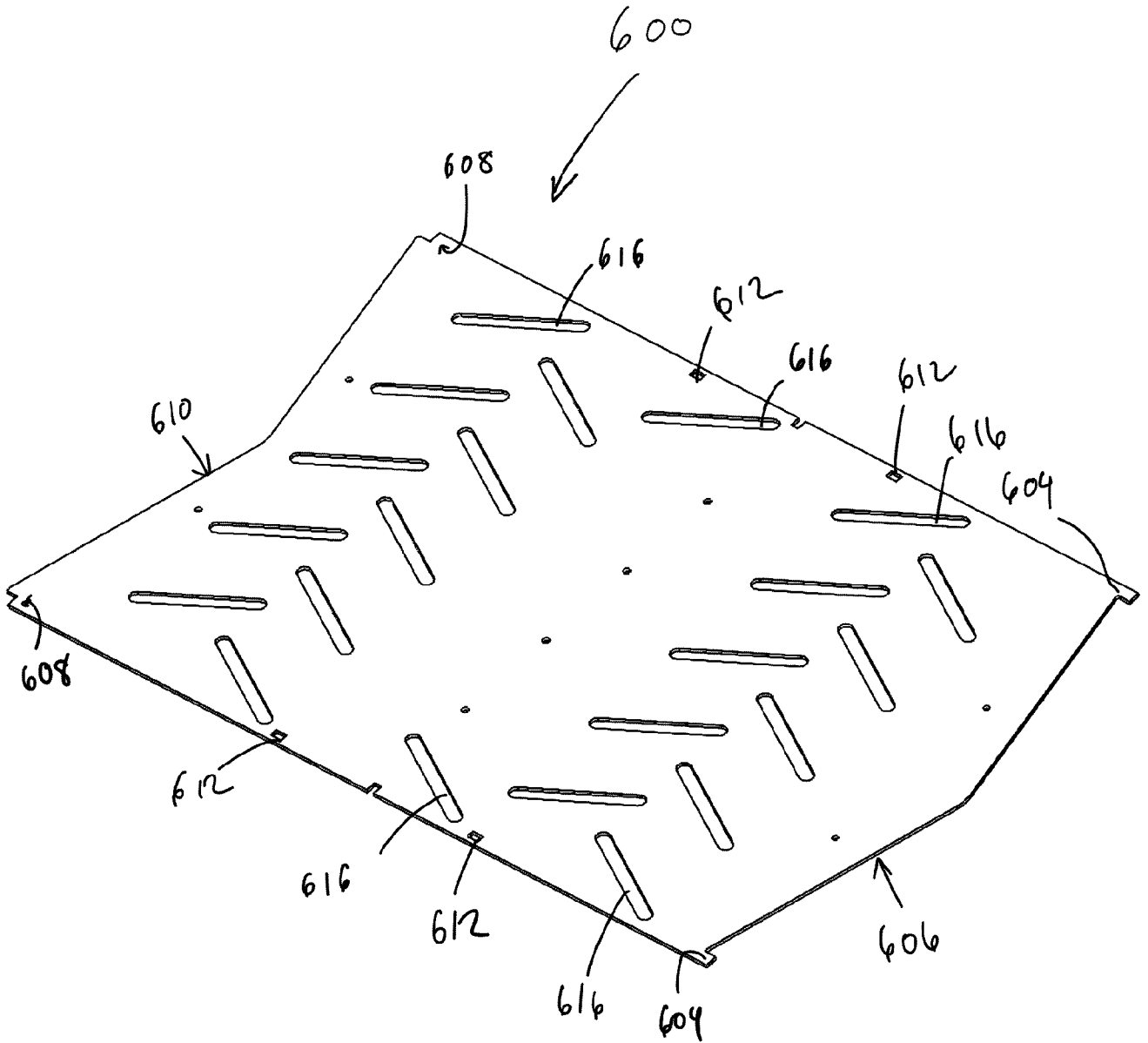

Fig. 27a

32/33

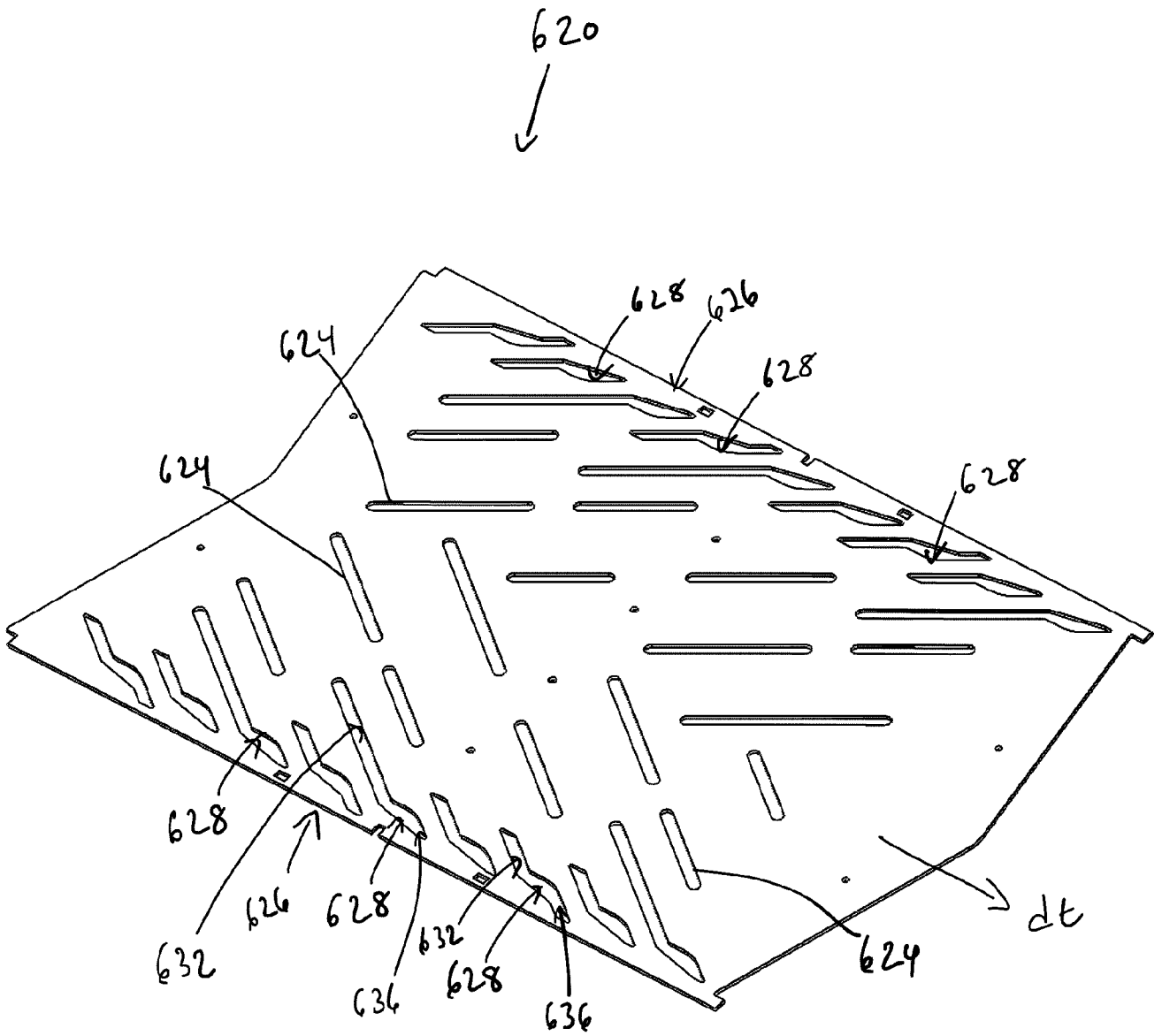

Fig. 27b

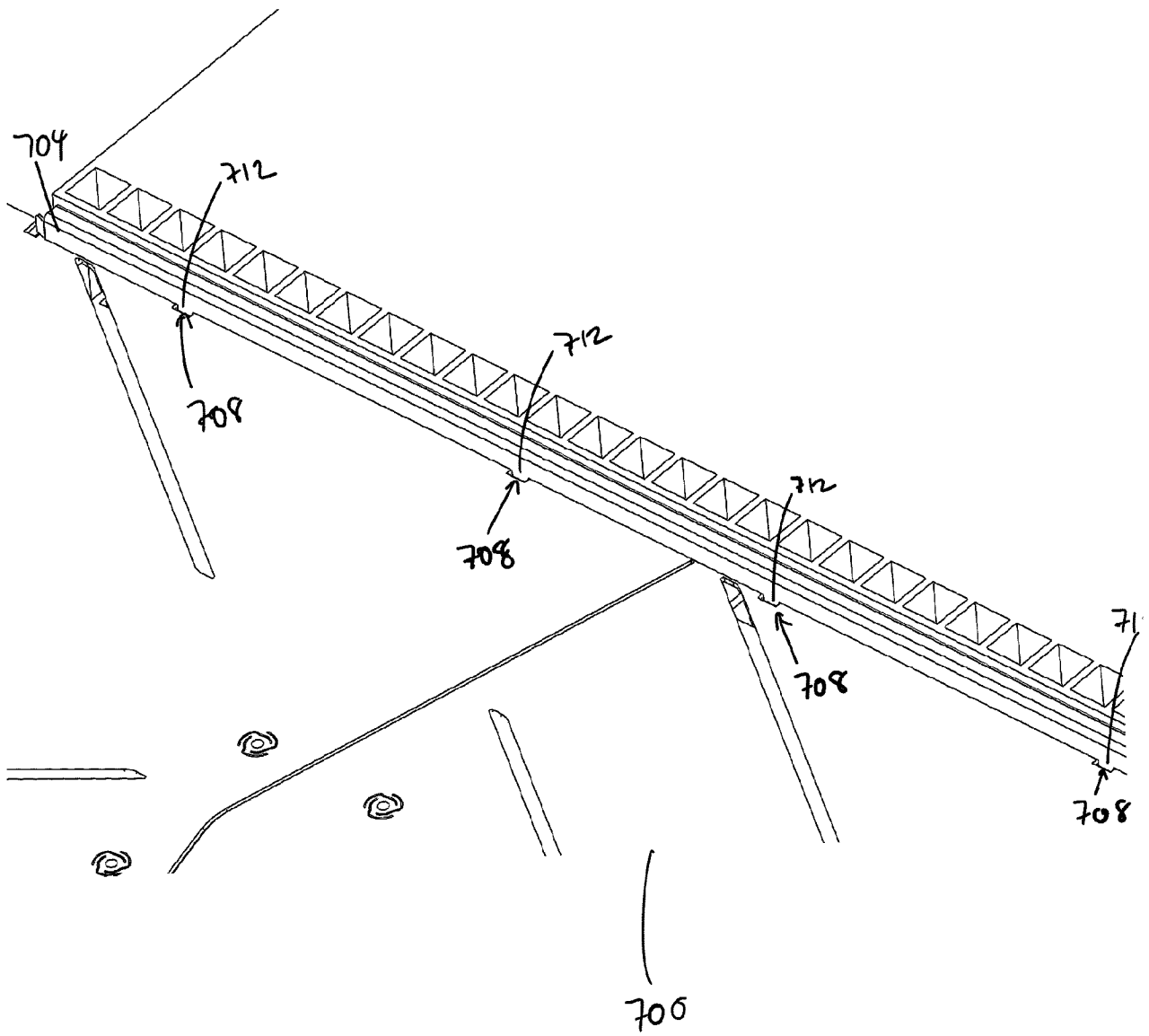

Fig. 28

INTERNATIONAL SEARCH REPORT

International application No.

PCT/CA2018/051594

A. CLASSIFICATION OF SUBJECT MATTER
 IPC: **B65G 45/22** (2006.01), **B60S 3/04** (2006.01), **B65G 21/00** (2006.01), **B65G 45/26** (2006.01), **B65G 49/02** (2006.01)

According to International Patent Classification (IPC) or to both national classification and IPC

B. FIELDS SEARCHED

Minimum documentation searched (classification system followed by classification symbols)
 IPC (2006.01): B60S 3/04, 3/06; B65G 21/00; B65G 45/22, 45/24, 45/26; B65G 49/02
 CPC: B60S 3/04, 3/06; B65G 21/00; B65G 45/22, 45/24, 45/26; B65G 49/02

Documentation searched other than minimum documentation to the extent that such documents are included in the fields searched

Electronic database(s) consulted during the international search (name of database(s) and, where practicable, search terms used)

QUESTEL_ORBIT: (FAMPAT)
 BELT, WEAR, PLATE?, STRIP?, PANEL?, THERMO?PLASTI+, POLYETHYLENE+, UHMW+, SPRAY+,

C. DOCUMENTS CONSIDERED TO BE RELEVANT

Category*	Citation of document, with indication, where appropriate, of the relevant passages	Relevant to claim No.
X Y	US5111929 A (PIERICK, R et al.) 12 May 1992 (12-05-1992) ***belt 32, support deck 210, 212, 214, polymeric wear plates 218, 220, 222, rinse system 172***	1, 5-7, 10,11, 15-17 2-4, 12-14
X Y	US6360879 B1 (CRAWFORD, G) 26 March 2002 (26-03-2002) ***belt 24, support deck 32, UHMWPE wear plate 34, apertures 58***	9, 19 2-4, 12-14
A	US4226325 A (VANDAS, E) 7 October 1980 (7-10-1980) ***belt 11, support deck 23, wear plates 35, rinse system 39***	1-19
A	US6978880 B2 (BARRETT, P) 27 December 2005 (27-12-2005) ***belt 605; support deck (rollers; column 1, ln 21-22) rinse system 100, 140***	1-19
A	CA2929335 A1(STEPHENSON, P et al) 2 August 2017 (2-08-2017) ***service line 10, belt 36, support deck 84, wear plate 88***	1-19

Further documents are listed in the continuation of Box C.

See patent family annex.

* "A" "E" "L" "O" "P"	Special categories of cited documents: document defining the general state of the art which is not considered to be of particular relevance earlier application or patent but published on or after the international filing date document which may throw doubts on priority claim(s) or which is cited to establish the publication date of another citation or other special reason (as specified) document referring to an oral disclosure, use, exhibition or other means document published prior to the international filing date but later than the priority date claimed	"T" "X" "Y" "&"	later document published after the international filing date or priority date and not in conflict with the application but cited to understand the principle or theory underlying the invention document of particular relevance; the claimed invention cannot be considered novel or cannot be considered to involve an inventive step when the document is taken alone document of particular relevance; the claimed invention cannot be considered to involve an inventive step when the document is combined with one or more other such documents, such combination being obvious to a person skilled in the art document member of the same patent family
--------------------------------------	--	--------------------------	--

Date of the actual completion of the international search
3 April 2019 (3-04-2019)

Date of mailing of the international search report
15 April 2019 (15-04-2019)

Name and mailing address of the ISA/CA
 Canadian Intellectual Property Office
 Place du Portage I, C114 - 1st Floor, Box PCT
 50 Victoria Street
 Gatineau, Quebec K1A 0C9
 Facsimile No.: 819-953-2476

Authorized officer

Darren Hubley (819) 639-7856

INTERNATIONAL SEARCH REPORT
Information on patent family members

International application No.
PCT/CA2018/051594

Patent Document Cited in Search Report	Publication Date	Patent Family Member(s)	Publication Date
US5111929A	12 May 1992 (12-05-1992)	AU1990392A DE69215671D1 DE69215671T2 EP0581877A1 EP0581877A4 EP0581877B1 ES2097332T3 WO9219521A1	21 December 1992 (21-12-1992) 16 January 1997 (16-01-1997) 03 April 1997 (03-04-1997) 09 February 1994 (09-02-1994) 22 February 1995 (22-02-1995) 04 December 1996 (04-12-1996) 01 April 1997 (01-04-1997) 12 November 1992 (12-11-1992)
US6360879B1	26 March 2002 (26-03-2002)	None	
US4226325A	07 October 1980 (07-10-1980)	None	
US6978880B2	27 December 2005 (27-12-2005)	US2005199471A1	15 September 2005 (15-09-2005)
CA2929335A1	02 August 2017 (02-08-2017)	CA2919812A1 US9650218B1 US2017217690A1 US9745142B2 US2018043864A1	02 August 2017 (02-08-2017) 16 May 2017 (16-05-2017) 03 August 2017 (03-08-2017) 29 August 2017 (29-08-2017) 15 February 2018 (15-02-2018)