

E. P. ARNOLD.  
 COMBINED GRAIN DRIER, COOLER, AND BLEACHER.  
 APPLICATION FILED MAY 20, 1908.

915,534.

Patented Mar. 16, 1909.  
 4 SHEETS—SHEET 1.

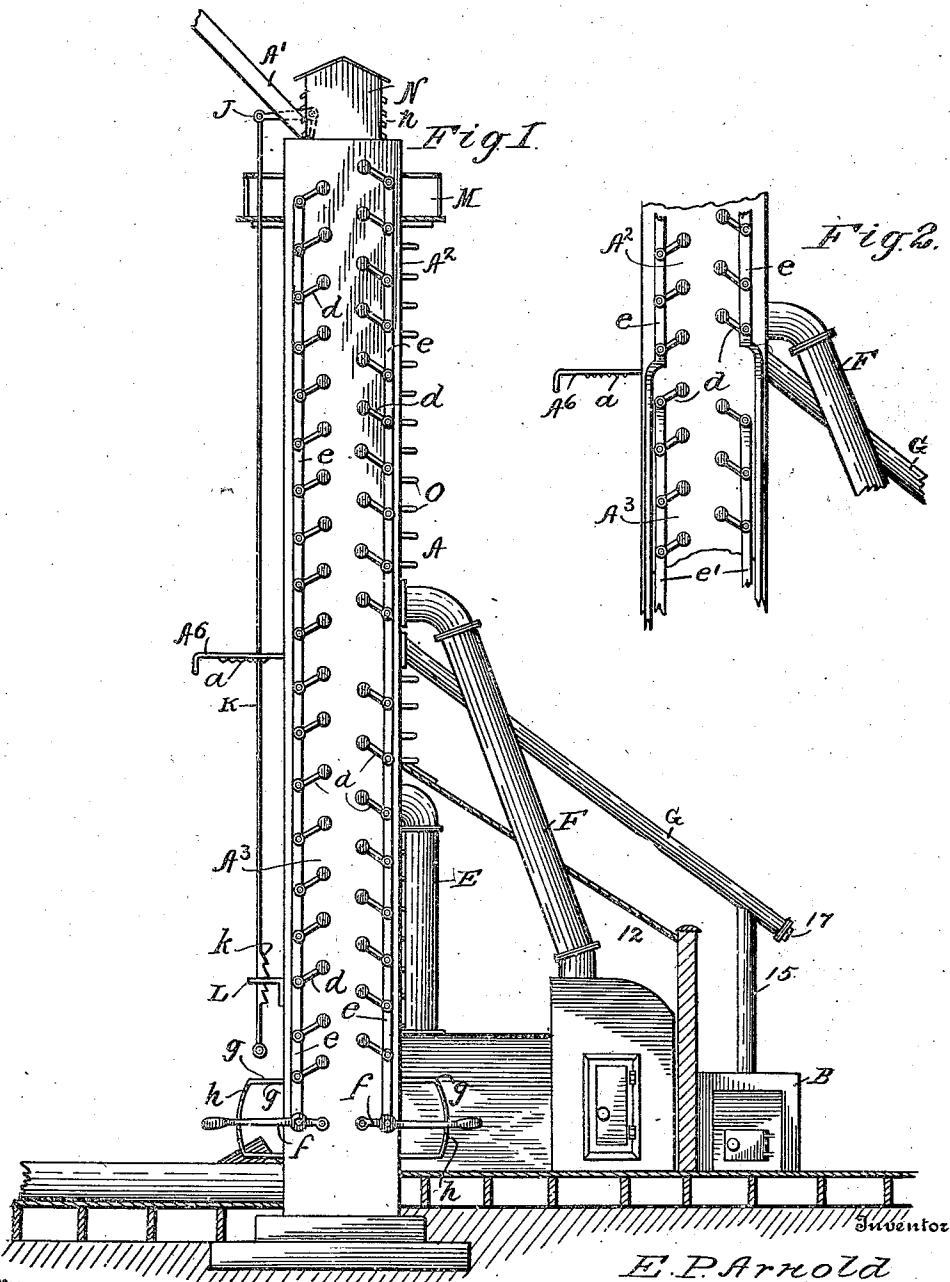

Witnesses  
 W. R. Edilen  
 E. Salisbury

Inventor  
 E. P. Arnold

By Alex. J. Wedderburn, Jr.  
 Attorney

E. P. ARNOLD.  
 COMBINED GRAIN DRIER, COOLER, AND BLEACHER.  
 APPLICATION FILED MAY 20, 1908.

915,534.

Patented Mar. 16, 1909.  
 4 SHEETS—SHEET 2.

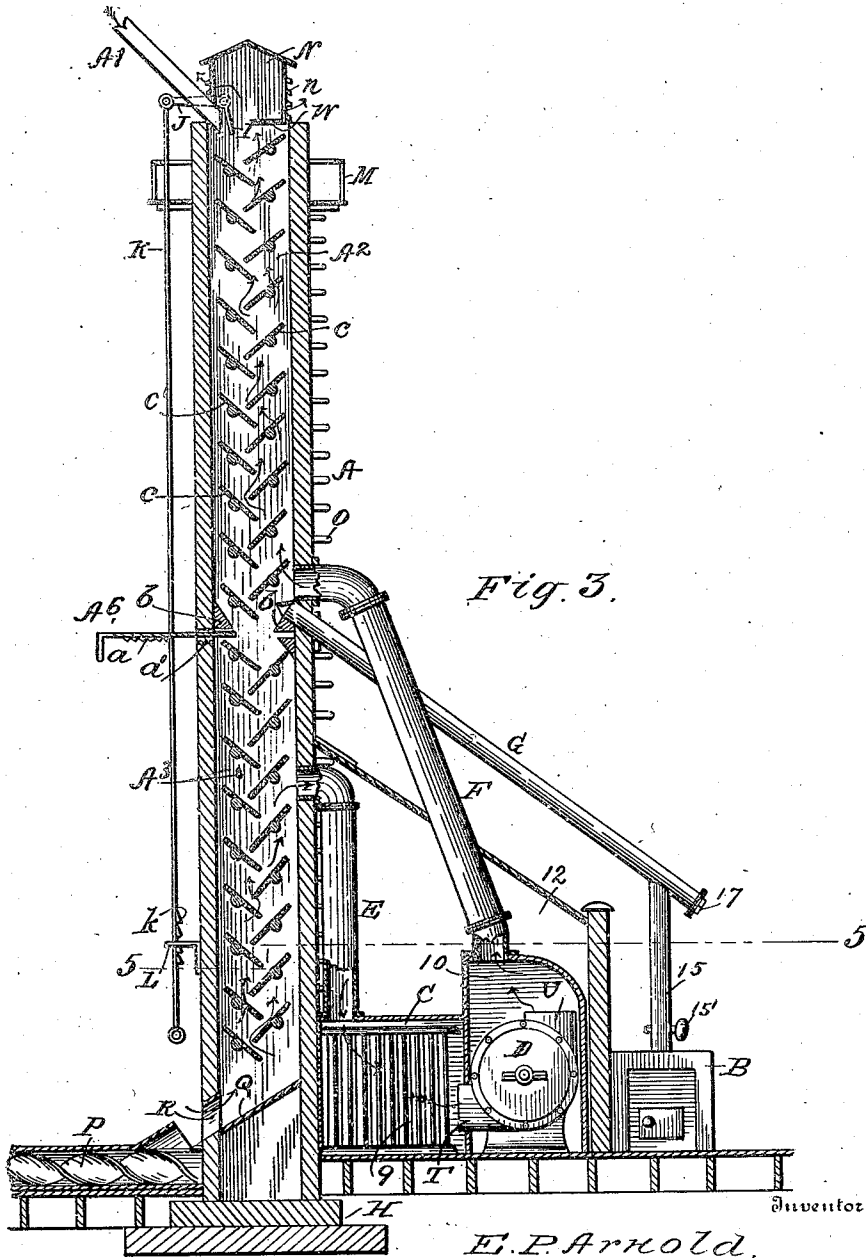

Fig. 3.

Inventor

E. P. Arnold.

Witnesses  
 W. R. Edelen.  
 E. Salisbury

334 Alex. J. Wedderburn, Jr.  
 Attorney

E. P. ARNOLD.  
 COMBINED GRAIN DRIER, COOLER, AND BLEACHER.  
 APPLICATION FILED MAY 20, 1908.

915,534.

Patented Mar. 16, 1909.

4 SHEETS—SHEET 3.

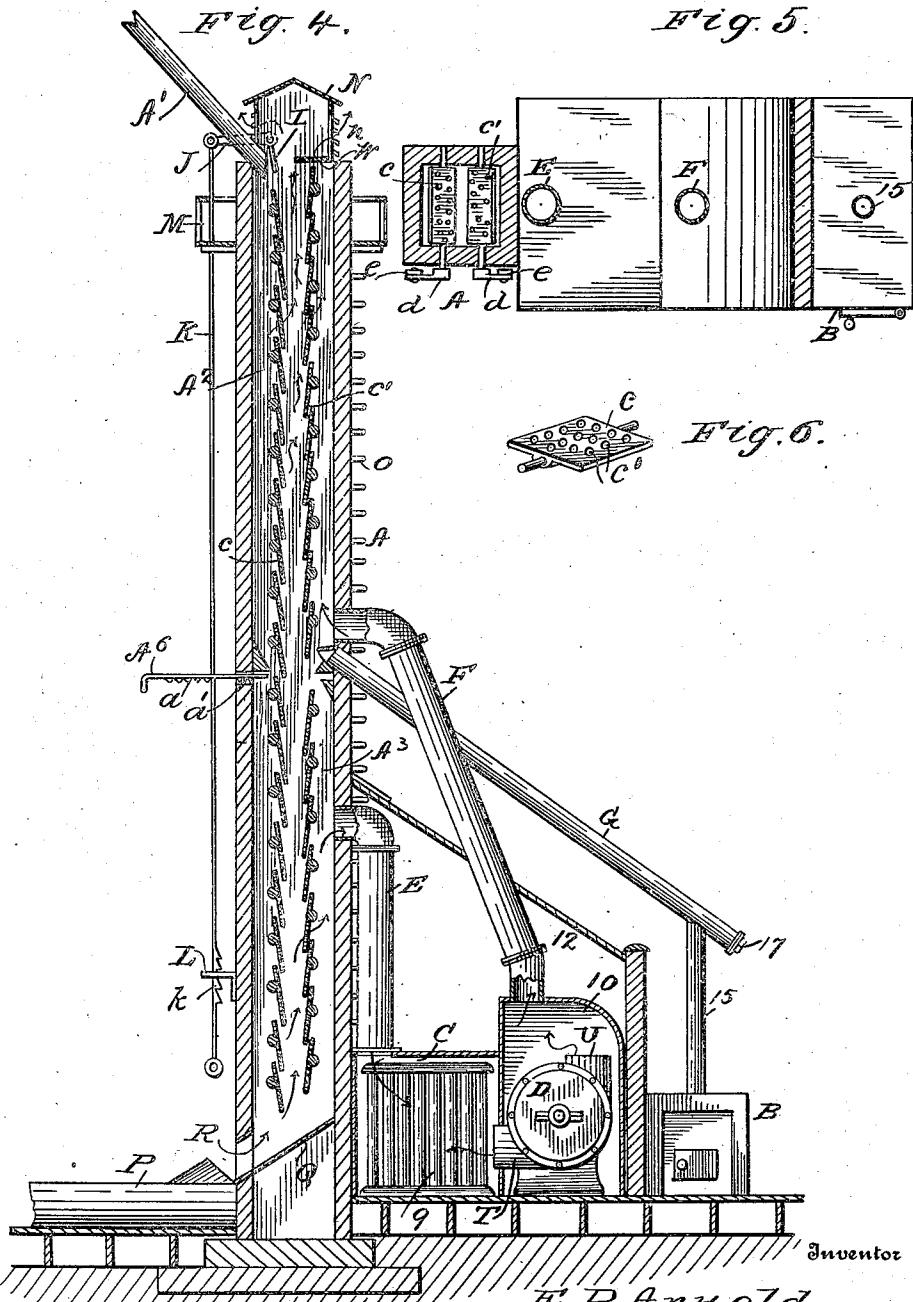

Witnesses

W. R. Edelen,  
 E. Salisbury

Inventor  
 E. P. Arnold.

By Alex. J. Wedderburn, Jr.

Attorney



# UNITED STATES PATENT OFFICE.

EDWARD PAXTON ARNOLD, OF CHICAGO, ILLINOIS.

COMBINED GRAIN DRIER, COOLER, AND BLEACHER.

No. 915,534.

Specification of Letters Patent.

Patented March 16, 1909.

Application filed May 20, 1908. Serial No. 433,842.

*To all whom it may concern:*

Be it known that I, EDWARD PAXTON ARNOLD, a citizen of the United States, residing at Chicago, in the county of Cook and State of Illinois, have invented certain new and useful Improvements in a Combined Grain Drier, Cooler, and Bleacher, of which the following is a specification.

This invention relates to improvements in a combined grain drier, cooler and bleacher, but more especially that class of apparatus wherein external air is employed through the medium of a fan or blower passing through a heating device and forced upward into a drying chamber for drying and cooling grain.

This invention further relates to the means for holding the grain in abeyance in the upper portion of a tower when the drying process is in operation: or the grain can be slowly passing down the tower as it is deflected by the shelves, during the bleaching process.

This invention further relates to the means for dividing the tower into two separate compartments whereby cold and also heated air is acted on simultaneously by a single fan or blower through the medium of suitable pipes for the purpose in view.

This invention further relates to the pivoted perforated shelves for regulating the descent of the grain at certain times during the process of treating.

This invention also relates to the means for preparing the bleaching products and conveying the fumes into the upper chamber or compartment of a tower by hot air from furnace alone, no fan or jet being used.

This invention also relates to the means for drawing cold air into the alternate opposing lower portion of a tower, upwardly into a conduit or pipe, thence downwardly to a steam coil chamber, through a fan into a hot air pipe or conduit, then again upwardly, into a drying compartment in a tower.

This invention also relates to the adjustable arrangement of the pivoted shelves which can be operated simultaneously to run grain fast or slow or to retain same for any length of time.

This invention also relates to the perforated pivoted shelves for allowing the bleaching fumes and hot air to pass there-through, and vented at the top of the tower; and other novel features of construction which will be described in the specification,

elucidated in the drawings and clearly pointed out in the claims.

The devices or apparatus in present use for treating various grains may have met the requirements sought in a certain degree, but not in a manner to warrant a commercial commodity of excellence and purity such as is produced through the instrumentalities of this method of treating grain.

The object of the present invention is to produce a drying, cooling and bleaching device all in one machine, and which will be economical in construction and in the method of producing the desired results in a quick and expeditious manner.

In the drawings similar characters of reference indicate corresponding parts in all the figures.

Figure 1 is a side elevation of the improved device, with the house in section, exhibiting the interior thereof. Fig. 2 is a side elevation in detail of the central portion of the tower, exhibiting independent rods for operating the shelf levers. Fig. 3 is a central longitudinal section of the apparatus, exhibiting the various instrumentalities associated with the device. Fig. 4 is also a central longitudinal section of the device, exhibiting the shelves in an extreme open position. Fig. 5 is a longitudinal section of the apparatus, taken on line 5—5, of Fig. 3, exhibiting the outline of the tower in cross section and also the shelves therein. Fig. 6 represents in a perspective view a shelf with the perforations therein. Fig. 7 represents a tower slightly modified in which a plurality of walls of shelves are indicated. Fig. 8 is a fragmentary section view of Fig. 7, exhibiting the opposite side thereof.

This invention consists of a number of very important devices, the functions or chief characteristics of which are, a tower A, a chemical furnace B, a heating compartment C, and a fan or blower D, in conjunction with a cold air pipe or conduit E, a hot air pipe or conduit F, and the bleacher pipe G.

The tower A, is located adjacent to a grain elevator, not shown in the drawings, and from which extends a pipe or chute A', which conveys the grain through gravity into the upper compartment A<sup>2</sup>, of the said tower A. Said tower A, is divided or bisected by a slide A<sup>3</sup>, thus forming two compartments A<sup>2</sup>, and A<sup>3</sup>, respectively. This division of said tower is for the purpose of

holding the grain at certain times during the drying process and hot air treatment in the compartment A<sup>2</sup>. The grain can be held permanently, if desired, in the upper compartment, but that is not absolutely essential, as the drying process can be maintained while the grain is passing slowly over the pivoted shelves *c*, and to the lower compartment A<sup>3</sup>, as the slide A<sup>6</sup> can be adjusted through the medium of the serration *a*, and *a'*, impinging on each other when desiring to regulate the flow of grain into the lower compartment A<sup>3</sup>. Adjacent to the slide A<sup>6</sup>, are deflectors *b*, *b'*, to centrally locate the grain as it passes into the lower compartment A<sup>3</sup>, and at the same time to allow the grain to pass slowly over the pivoted shelves *c*. Said shelves *c* are provided with perforations *c'*, to allow the various products to pass through when drying and cooling the grain, and also during the process of bleaching.

The pivoted shelves *c*, are provided with levers *d*, and operated by means of rods *e*, pivoted to the ends of said levers *d*. At the lowermost part of said rods *e*, are pivoted levers *f*, for regulating the pivoted shelves *c*, through the medium of frames *g*, which are provided with notches *h*, securing said levers *f*, when adjusting the perforated shelves *c*. In Figs. 1, 3 and 4 of the drawings, the levers *d*, are all pivoted to continuous rods *e*, whereby the levers *d*, on opposite sides of the tower A, are operated by a single rod *e*, on said sides. It may occur at times when treating grains, that it will be required to operate the lever *d*, attached to compartments A<sup>2</sup>, and A<sup>3</sup>, separately. To meet such an emergency, separate rods *e'*, are provided to operate the shelves in compartment A<sup>3</sup>, independent of those in compartment A<sup>2</sup>, which is fully illustrated in Fig. 2 of the accompanying drawings.

When treating grain the amount or rate of flow of the grain from the elevator is regulated by means of a damper or door I, adjacent to the pipe or chute A'. Said damper is operated by a lever J, through the medium of a rod K, which is provided with notches *k*, near the lowermost part thereof, for engagement with a bracket L. Near the top of the tower A, is a platform M, which is available by means of a ladder O. On the top of the said tower A, is a vent house N, which is provided with openings *n*, to allow the confined gases in the chamber A<sup>2</sup>, to escape when desired. At the lowermost portion of tower A, adjacent to the foundation H<sub>2</sub> is a conveyer P, for removing the treated grain to some suitable receptacle. Adjacent to said conveyer P, and within the tower A, is an inclined slide Q, for forcing the grain to slide into said conveyer through the aperture R, formed in said tower A. The aperture R, is also for the purpose of allowing the cold air to be drawn into the compartment A<sup>3</sup>, by

means of a fan D, through the mouth T. As the cold air enters said chamber A<sup>3</sup>, it is drawn upward into the pipe E, and thence downward into the chamber C, where it becomes heated by means of the steam coil 9, after which it enters the fan aforesaid passing out the mouth U, into the chamber 10, the air thus becoming heated in its passage around said steam coil or radiator. The heated air is forced by the fan into the pipe F, and conveyed into the compartment A<sup>2</sup>, upward and vented through the vent house N.

A house 12, is provided to protect the various parts mentioned not otherwise protected from the elements. Adjacent to the house 12, is a chemical furnace B, for producing fumes, which may be sulfur or other products that will accomplish the required results. The fumes from said furnace are conveyed through pipes 15, and G, (over the free end of pipe G, is a shield to prevent grain from entering said pipe) and thence into the compartment A<sup>2</sup>, when the bleaching process is required. A damper 15' is employed in pipe 15, to regulate the sulfur fumes when bleaching. At the lowermost portion of pipe G, is a plug 17, for cleaning said pipe when necessary. During the process of bleaching, the heat from the chemical furnace is sufficient to carry the sulfur fumes to the tower.

In operating my improved apparatus the grain is conveyed to the tower A, through pipe A', and the flow of grain is regulated by the damper I, by means of a rod K, either from the bottom of the tower, or from the platform M, which is reached by means of the ladder O. When operated from the platform, the rod K, is detached and the lever J is hand operated. In regulating said damper I, it will be observed that the damper I, cannot be forced away from the mouth of the pipe A', when operated by the rod K, as any undue pressure on said damper I, when an elevator is filled with grain, will be retarded as the notches *k*, on the rod K, press against the top of the catch or bracket L, and thus retain the damper in its proper position.

As the grain is conveyed into the tower A, see Fig. 3, it will pass over or rebound slightly on the perforated shelves *c*, while the sulfur fumes from the pipe 16, will enter the chamber and pass around said shelves and also through the perforations *c'*, thus becoming thoroughly mixed with the grain being treated. The shelves being shown, in Fig. 3, at an angle of about 45 degrees will retard the sulfur fumes and allow the portions of the grain to become thoroughly treated. At certain stages in the process of heating the grain the shelves *c*, are closed and form vertical walls as indicated in Fig. 4. The hot air will pass through the perforations *c'*, into the center of the tower between the two rows of closed shelves. To prevent the products from es-

caping from the tower except through the perforations *c*, a partition *W*, is put on top of one side of the tower as indicated in Figs. 3 and 4 of the drawings.

5 The slide *A*<sup>6</sup>, is closed or partly closed at certain stages of the process of treating the grain. The fumes after passing through the grain are vented through the top of the tower.

When the operation of treating the grain begins, the cold air is drawn into the compartment *A*<sup>3</sup>, through the aperture *R*, and down the pipe *E*, by means of a fan or blower *D*, where the cold air enters the chamber *C*, and in passing around and through the steam coil or radiator *9*, it becomes heated, after which it is drawn into the opening *T*, and exhausted into the chamber *10*, through the opening *U*, and forced upward through the hot air pipe *F*; as aforesaid. As the grain is treated when the slide *A*<sup>6</sup> is not entirely closed, the grain passes into the chamber or compartment *A*<sup>3</sup>, commingling with the cold air as it is drawn upwardly toward the pipe *E*, thus cooling the grain before entering the conveyer *P*, by way of the slide *Q*, and outwardly into a receptacle. As grains vary, thereby requiring different treatment, it is arranged so that the rods *e*; and *e'*, will operate the shelves *c*, in such a manner as to make a continuous channel, as indicated in Fig. 4, of the accompanying drawings. The grain can be treated whether descending quickly or slowly down the tower, by the sulfur fumes. When the perforated shelves *c*, are perpendicular or obliquely open they form two perforated walls, with grain between, with a closed hot air chamber at one side, and open exhaust chamber on the other side, as indicated in Figs. 1, 3 and 4.

40 In the modification indicated in Figs. 7, and 8, additional walls of shelves are shown. The sulfur or chemical pipe *G*, the hot air pipe *F*, and the cold air pipe *E*, all enter in the rear of the tower *A*, at a central point between the walls of the perforated shelves *c*. The products from the aforesaid pipes pass centrally through the tower *A*, and in the upward passage, said products are retarded by the partition or cover *w*, consequently the products emanating from the various pipes have to pass through the perforations *e'*, formed in the perforated shelves *c*, through the grain passing between the walls of the shelves. The products finally escape through the exhaust passage adjacent the walls of the tower *A*, and thence through the vent *N*. Within the vent houses are located hoppers *T*, for feeding the grain in the tower.

Having described my invention, that which I desire to secure by Letters Patent is:

1. An apparatus for treating grains, consisting of a tower, said tower being provided with a slide centrally located, so as to form two compartments within said tower, centrally pivoted shelves arranged in series lo-

70 cated within both compartments of said tower, said series of shelves being operated independently of each other, a hot air pipe and a chemical pipe entering said tower, for the purpose as shown and described.

2. An apparatus for treating grain, consisting of a tower, said tower being bisected by an adjustable slide for forming two compartments within said tower, alternate opposing centrally pivoted shelves arranged within said tower, the means for adjusting said shelves, in combination with a hot air and a chemical pipe entering said tower as herein shown and described, and the means for forcing hot air into said tower as specified.

3. An apparatus for treating grain, consisting of two compartments within a tower, opposing pivoted shelves arranged within said tower, a cold air pipe on the outside of said tower and extending upwardly and entering the wall of said tower, a heating chamber communicating with said cold air pipe in combination with a fan for drawing air through the lower part of said tower thence into said heating chamber through said cold air pipe, a chemical pipe entering said tower and the means for conveying hot air into the upper compartment of said tower, as shown and described.

4. An apparatus for treating grains, consisting of a tower, perforated shelves within said tower, centrally pivoted, a slide for dividing said tower into two compartments, of a chemical furnace adapted to force fumes into the upper compartment of said tower, a hot air pipe entering said compartment, and the means for heating said air as specified.

5. An apparatus for treating grains, consisting of a tower, a feed pipe at the top of said tower, and regulated by a damper, means connected to said damper for operating from the bottom of the tower, pivoted, perforated shelves within said tower, means at the bottom of the tower for transferring the grain from said tower, as shown and described.

6. An apparatus for treating grains consisting of a tower with an opening in the lower portion thereof for the admission of atmospheric air, said tower being divided into two compartments, a slide centrally located within said tower, serrations on said slide to hold it in any desired position, pivoted shelves within said tower, means for adjusting said shelves from the outside of said tower, a steam coil adjacent to said tower, a fan for drawing air through the opening in said tower into said steam coil and forcing the air in a heated condition into the upper compartment of said tower, in combination with a chemical furnace forcing sulfur or other fumes into said upper compartment as specified.

7. An apparatus for treating grains, consisting of a tower, several series of alternate

70

75

80

85

90

95

100

105

110

115

120

125

130

opposing centrally pivoted shelves located within said tower, a chemical pipe entering said tower, each series of said shelves being independently adjustable, a steam coil adjacent to said tower, and provided with a cold air pipe and a hot air pipe the free ends of which enter said tower, of a fan for drawing cold air through said steam coil and forcing said air through said hot air pipe into said tower, a furnace for producing sulfur fumes, which pass through said chemical pipe communicating with said tower for treating the grain within, as specified.

8. An apparatus for treating grains, consisting of a tower, alternate opposing pivoted perforated shelves within said tower, rods on the outside of said tower, operating levers connected to said pivoted perforated shelves, of levers at the bottom of said tower for operating said rods when adjusting said shelves, means for regulating said levers at the bottom of said tower, as shown and described.

9. An apparatus for treating grains, which consists of two compartments, one above the other, independently pivoted shelves in each apartment, and means for operating said pivoted shelves independently when treating grain, as shown and described.

10. An apparatus for treating grain provided with a plurality of walls formed by adjustable perforated shelves arranged in a manner to form two passageways for material being treated and to leave a central space therebetween and a cover closing the top of said central space, for the purpose as shown.

11. An apparatus for treating grain which is provided with a tower, a plurality of walls formed by perforated shelves within said tower, said walls arranged so as to form two passageways for material being treated and to leave a central space therebetween, a cover closing the top of said central space, and a hot air pipe and a chemical pipe entering said central space, as shown and described.

12. An apparatus for treating grain, consisting of a plurality of walls formed by pivoted perforated shelves, said walls arranged so as to form a central passageway between said shelves, a cover closing said central passageway for retarding the various gases ascending in said central passageway,

an exhaust chamber and perforated shelves for allowing said gases to escape through grain into said exhaust chamber, as specified.

13. An apparatus for treating grain consisting of a tower, said tower being divided into two compartments, an adjustable slide centrally located within said tower, a series of independently operated shelves located within each compartment of said tower, a hot air pipe and a chemical pipe entering the upper compartment of said tower, means for drawing atmospheric air into the lower compartment of said tower, a cold air pipe for the passage of air from the lower compartment of said tower into a heating chamber and means for forcing heated air into said upper compartment of said tower in combination with a chemical furnace as shown and described.

14. An apparatus for treating grain consisting of a tower, a centrally located slide forming two compartments within said tower, rows of shelves within each compartment of said tower, said shelves being perforated, pivoted and arranged in series and each series being independently adjustable, means for drawing atmospheric air into the lower compartment of said tower, means for introducing a chemical fume into the upper compartment of said tower and means for forcing a hot air blast into the upper compartment of said tower.

15. An apparatus for treating grain consisting of a tower, rows of centrally pivoted, perforated shelves within said tower, said shelves being adjustable so as to form opposing continuous walls between which a solid column of grain can pass, means for forcing chemical fumes, hot or cold air through the shelves and particles of grain passing between said shelves, an opening at the top of said tower for the escapement of fumes and air, a grain feed at the top of said tower and a means for conveying the treated grain from said tower.

In testimony whereof I affix my signature, in presence of two witnesses.

EDWARD PAXTON ARNOLD.

Witnesses:

WILL. M. GADSDEN,  
EDW. W. LEEPER.