

(No Model.)

2 Sheets—Sheet 1.

F. F. RAYMOND, 2d.
NAIL MAKING MACHINE.

No. 342,929.

Patented June 1, 1886.

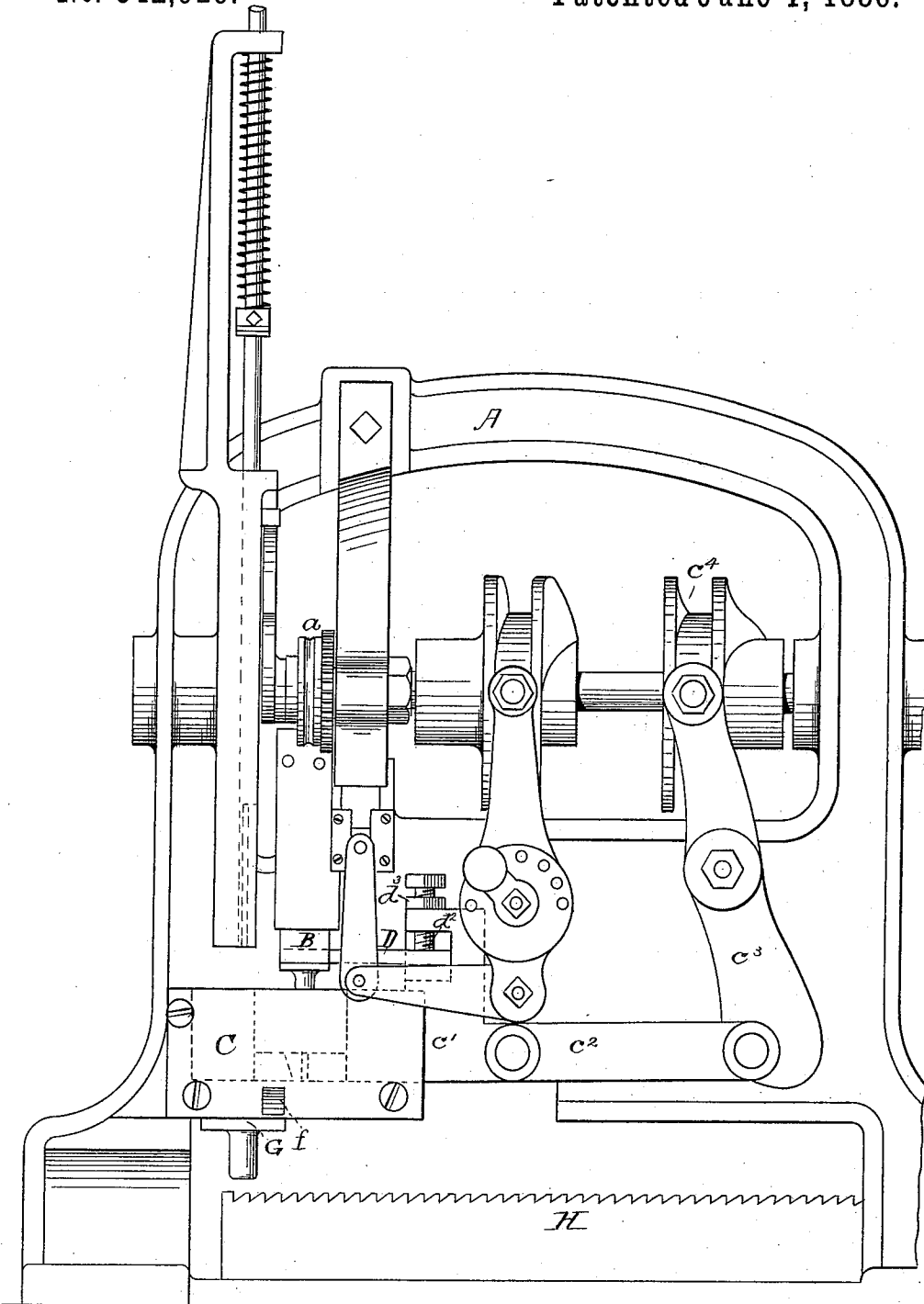

WITNESSES.

Wm. B. Dolan
J. W. Dolan

Fig. 1.

INVENTOR.
F. F. Raymond

(No Model.)

2 Sheets—Sheet 2.

F. F. RAYMOND, 2d.
NAIL MAKING MACHINE.

No. 342,929.

Patented June 1, 1886.

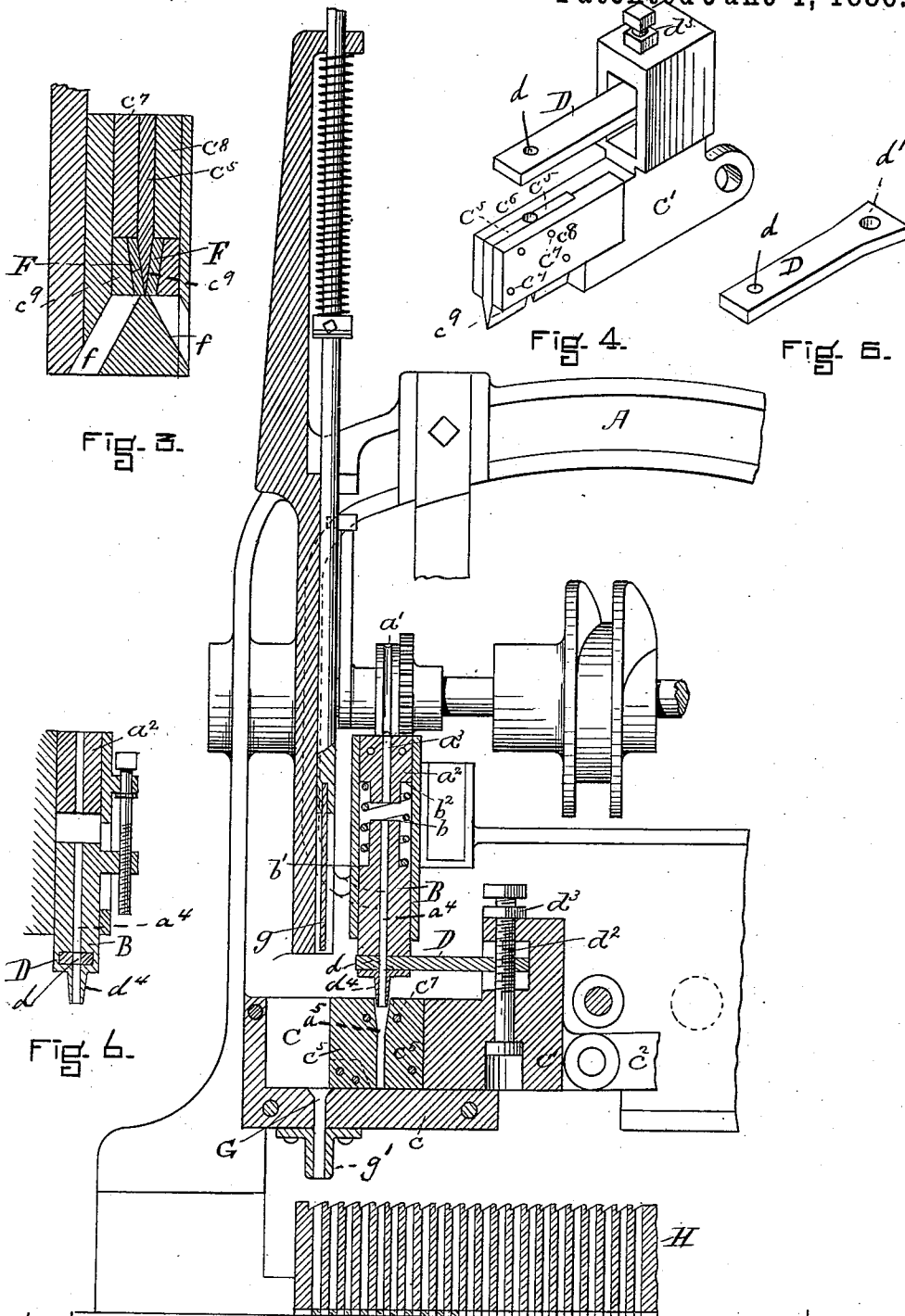

WITNESSES
 Fred. B. Deane
 J. W. Deane

FIG. 2.

INVENTOR:
 F. F. Raymond

UNITED STATES PATENT OFFICE.

FREEBORN F. RAYMOND, 2D, OF NEWTON, MASSACHUSETTS.

NAIL-MAKING MACHINE.

SPECIFICATION forming part of Letters Patent No. 342,929, dated June 1, 1886.

Application filed December 16, 1885. Serial No. 185,810. (No model.)

To all whom it may concern:

Be it known that I, FREEBORN F. RAYMOND, 2d, of Newton, in the county of Middlesex and State of Massachusetts, a citizen of the United States, have invented a new and useful Improvement in Nail-Making Machines, of which the following is a full, clear, and exact description, reference being had to the accompanying drawings, forming a part of this specification, in explaining its nature.

The invention is an improvement upon that described in my Letters Patent No. 317,199, and upon that described in the application of A. O. Towns and myself, filed November 27, 1885, Serial No. 184,048, for nail making and distributing machines; and it relates especially to the mechanism or devices for varying the length of nail severed or cut from the wire.

Referring to the drawings, Figure 1 is a view in front elevation of a machine having my invention. Fig. 2 is a view in vertical section and elevation of the portion of said machine to which my invention relates. Figs. 3, 4, and 5 are detail views; and Fig. 6 illustrates a modification.

A represents the frame of the nail-making machine. It supports the feed-rolls a and a' . They are like those described in the said application of Towns and myself, and they are operated by mechanism, substantially as therein set forth, to vary the feed of the wire. Below the feed-rolls is a fixed block, a^2 , in which is a feedway or passage, a^3 , for the wire, and below this stationary block there is arranged the movable block B, which has a passage or feedway a^4 , in continuation of the feedway of the block a^2 . This block B is movable vertically in relation to the block a^2 in suitable guides or ways, either by means of a spring, b , which may surround it and bear against the shoulder b^1 thereon and against the shoulder b^2 of the block a^2 , or it may be moved vertically by means of a screw, as represented in Fig. 6. For the purposes of the invention, however, it is immaterial how this block is provided with a vertical movement. There is arranged to be reciprocated across the lower edge of this block, in a suitable passage or guideway, C, in the block c , the nail cutting and carrying devices, and these comprise the block c' , adapted to be positively reciprocated

by means of the link c^2 , lever c^3 , and cam c^4 . This block c' supports the die-pieces c^5 , which preferably are shaped in side and end elevation as represented in Figs. 2 and 3. They form a passage or feedway, a^5 , in continuation of the passage a^4 . The die-pieces are fastened to an extension, c^6 , of the block c' by dowel-pins c^7 passed through holes therein and the covering-plate c^8 , which is screwed to said extension c^6 , and when thus secured the inclined surfaces c^9 of the die-pieces project into the guideway or passage C. Above the die-pieces c^5 is a wire-cutting plate, D, which has a hole, d , adapted to be brought in line with the feedway a^4 . This plate D is made vertically movable in the block c' in any desired way, and I have represented it as provided with the tongue-projection d' , which enters a recess of corresponding shape in the block. This tongue may have a hole for the reception of a steady-pin, and it has a screw-hole for the reception of the screw-spindle d^2 , carried by the block c' , and by which it is moved vertically. A check-nut, d^3 , may be used for locking the screw after the plate has been moved to the desired position. The plate D or block B may also have a sleeve or tube, d^4 , arranged so that its passage shall be in continuation of the hole d , and having a slightly-tapering exterior arranged to shut into the slightly-tapering hole of the die-pieces c^5 , so that the tube can have a vertical movement in the passage as the plate D and block B are raised or lowered in relation to the portion c^6 of the block.

In the operation of severing a nail or nail-blank from the end of the wire the wire is fed by the feeding devices through the feedway a^3 a^4 to the lower edge of the die-pieces c^5 , coming in contact or very nearly in contact with the lower surface of the guideway C. The movement of the block c' will cause the cutting-plate D to sever the wire on the line of its upper surface as the block and plate are moved horizontally past the block B, and in order to secure (with a proper feed) nails varying in length it is only necessary to adjust the height or position of the block B and that of the cutting-plate D in relation to the section or portion c^6 of the block. For instance, if it is desired to cut a short nail or blank from the wire, the feed is adjusted to feed the length

of wire desired, and the cutting-plate D is moved downward in its holding-block to the desired position, and the block B also moved downward to correspond or so that its under surface shall come in contact with the upper surface of the plate D, and upon the forward movement of the block *c'*. The result is that the nail will be severed by the cutting action of the cutting-plate D as it moves by or past the end of the feedway. If it is desired to obtain a longer nail, the feed is adjusted, the block B is moved upward as well as the cutting-plate D, and as that changes the length of the hole in the carrying-block it is obvious that upon the movement thereof a longer nail or blank will be cut.

The cutting-plate may be made of hardened steel, and the block B provided with a hardened-steel die-plate.

To point the nail or blank after it has been severed from the wire, I have arranged the pointing-cutters F to project into the guideway C upon a line with the bevel or inclination of the die-plates. These cutters are fastened in place by screws or in any other way, and are so arranged as to sever from the lower end of the nail or blank held in the die such portions thereof as shall project on either side from the two side surfaces of the die, and the waste or sections of the blocks thus removed drop from the guideway through the escape-passage *f*. These cutters are similar in form and arrangement to the cutters shown and described in my Patents Nos. 317,199 and 317,851, and they bear the same relation to the nail-carrying block—that is, they are stationary, and are inclined in relation to each other, and the nail-carrying block is arranged to carry or move the nails past them.

The cutters may have any inclination, and may be arranged upon the same line, or one in advance of the other, as may be desired, and they of course are arranged to conform to the inclination of the lower portion of the die-plate. The carrying-block *c'* may be arranged to carry the nail or blank by or past the cutters, and then immediately back to a passage in the throat, arranged in continuation of the passage *a'*, by which it is discharged from the machine; but the construction I prefer and have illustrated is adapted to feed the wire blank past the cutters to the throat G, in which the driver or reciprocating rod *g* is arranged. This throat G is arranged in a nozzle, *g'*, and so as to come in line with the hole or passage *a'* of the carrier-block *c'* when it has been moved forward past the cutters.

The reciprocating rod or driver is operated by a spring and lifting-cam or by a cam only, as may be desired. In the drawings I have represented a spring and lifting-cam, and they are so timed that upon the movement of the nail into position beneath the rod *g* the rod is released and the spring forces it through the passage *a'* of the carrying-blocks, and through

the passage G in the throat, forcing the nail from the carrier-block into a hole of the traveling nail receiving and delivery block H, which has been previously moved into line with the throat G. The traveling nail receiving and delivery block which I prefer to use is like that described in the said application of Towns and myself, and is operated as therein described. I would say, however, that for the purposes of this invention I do not confine myself to a special form of receiving and delivery block, but may use any adapted to receive nails from the throat in successive order and transfer them for delivery.

I would further state that so far as the cutting and severing devices are concerned they may be used in a nail-driving as well as in a nail-making machine, where it is desirable to make and drive nails of varying lengths.

In operation, the cutter-block D and the block B are adjusted to cut nails of the length desired, and upon the operation of the machine the wire is fed by the feed-roll through the feedway *d* into the hole in the cutter-block D and die-block, and upon a horizontal or forward movement of these parts the cutter-block D severs the nail-blank or nail from the end of the wire, and by a continued forward movement the wire-blank is carried past the cutters, whereby its lower end is brought to a position beneath the rod *g*, which is then released to drive or move the nail from the carrier-block through the throat into the feedway-hole of the nail receiving and delivery block H. The rod is immediately lifted and the carrier-block returned to its original position to receive the section of wire which forms the next nail. Meanwhile the nail receiving and delivery block has been operated, as described in the said application referred to, to bring another nail-receiving hole in line with the throat, and the operation proceeds as before.

Having thus fully described my invention, I claim and desire to secure by Letters Patent of the United States—

1. In a nail-making machine, the combination of the reciprocating block *c'*, having a passage or feedway, *a'*, with a cutter, D, vertically movable in relation to the said block *c'*, and adapted to be reciprocated therewith, all substantially as described.

2. The combination of the adjustable block B, the movable block *c'*, having a nail-receiving hole, and the adjustable cutter plate or block D, all substantially as described.

3. In a nail-making machine, the vertically-adjustable cutting or shearing plate or block D, in combination with the movable block B, having a passage or feedway therein, all substantially as described.

4. The combination of the reciprocating block *c'*, the reciprocating cutter D, and means for adjusting or moving it vertically in relation to the said block, substantially as described.

5. The combination of the block c' , the cutting-block D, the adjusting-screw d^2 , and lock-nut d^3 , substantially as described.

6. The combination of the block B, having the feed-way a' , the spring b , and the adjustable cutter D, substantially as described.

7. The combination of the die-plate or lower part of the block c' , having the hole with the

movable cutting-block D, and a sleeve or tube extending from said block into the hole in the die-piece or lower part of the cutting-block, as and for the purposes described.

FREEBORN F. RAYMOND, 2D.

Witnesses:

FRED. B. DOLAN.

J. M. DOLAN.