



US 20140277415A1

(19) **United States**
(12) **Patent Application Publication**
PANIAGUA et al.

(10) **Pub. No.: US 2014/0277415 A1**
(43) **Pub. Date: Sep. 18, 2014**

(54) **METHOD OF DEPLOYING A PERCUTANEOUS REPLACEMENT HEART VALVE**

8,308,797, which is a continuation-in-part of application No. 10/037,266, filed on Jan. 4, 2002, now abandoned.

(71) Applicant: **Colibri Heart Valve LLC**, Broomfield, CO (US)

Publication Classification

(72) Inventors: **David PANIAGUA**, Houston, TX (US);
R. David FISH, Houston, TX (US)

(51) **Int. Cl.**
A61F 2/24 (2006.01)

(73) Assignee: **Colibri Heart Valve LLC**, Broomfield, CO (US)

(52) **U.S. Cl.**
CPC *A61F 2/2427* (2013.01)
USPC **623/2.11**

(21) Appl. No.: **14/284,063**

(57) **ABSTRACT**

(22) Filed: **May 21, 2014**

A method of making a replacement heart valve device whereby a fragment of biocompatible tissue material is treated and soaked in one or more alcohol solutions and a solution of glutaraldehyde. The dried biocompatible tissue material is folded and rehydrated in such a way that forms a two- or three-leaflet/cusp valve without affixing of separate cusps or leaflets or cutting slits into the biocompatible tissue material to form the cusps or leaflets. After the biocompatible tissue material is folded, it is affixed at one or more points on the outer surface to the inner cavity or a stent.

Related U.S. Application Data

(63) Continuation of application No. 13/675,665, filed on Nov. 13, 2012, which is a continuation of application No. 10/887,688, filed on Jul. 10, 2004, now Pat. No.

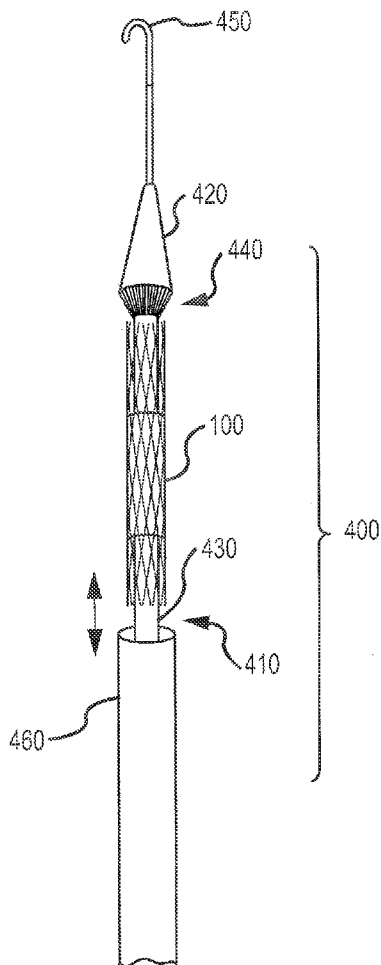

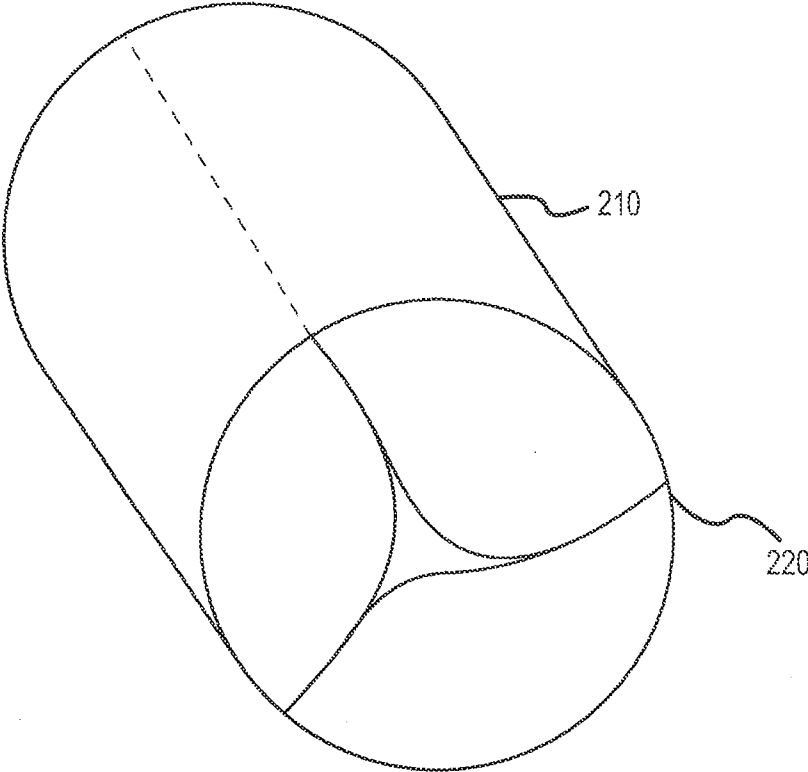

FIG.1

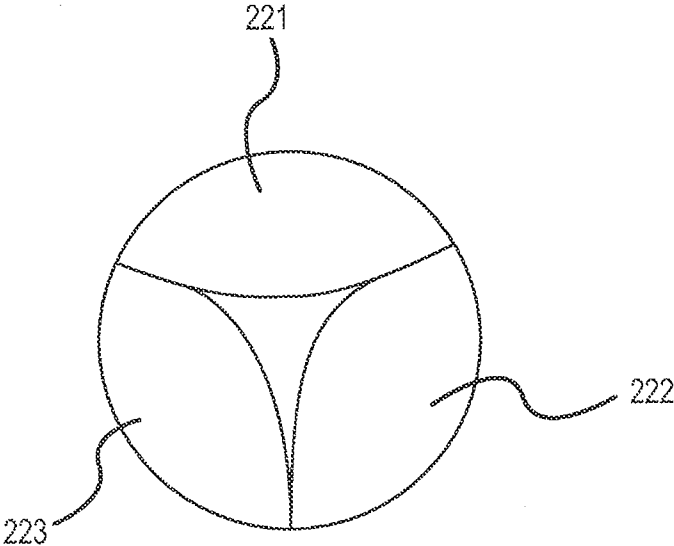

FIG.2

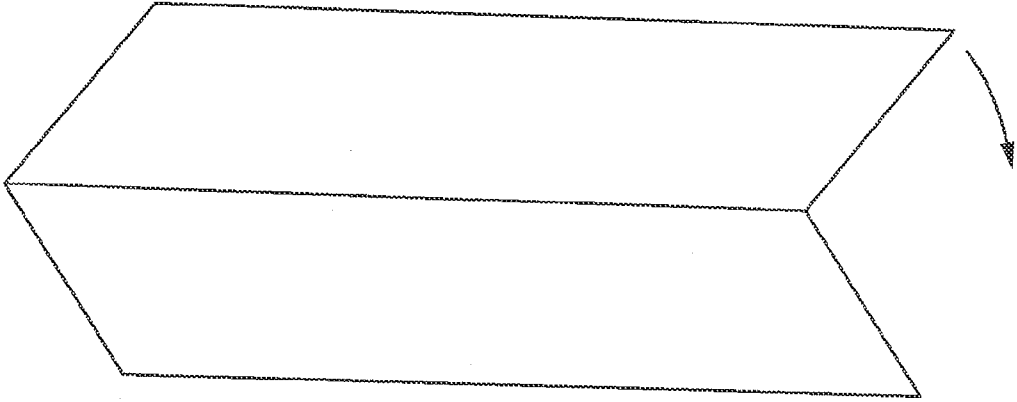

FIG.3A

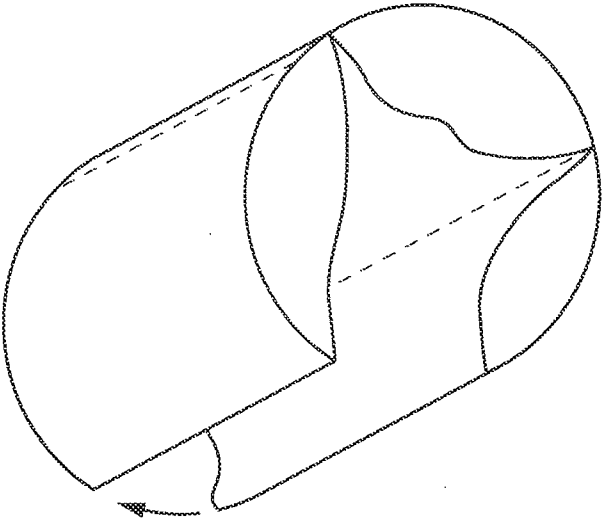

FIG.3B

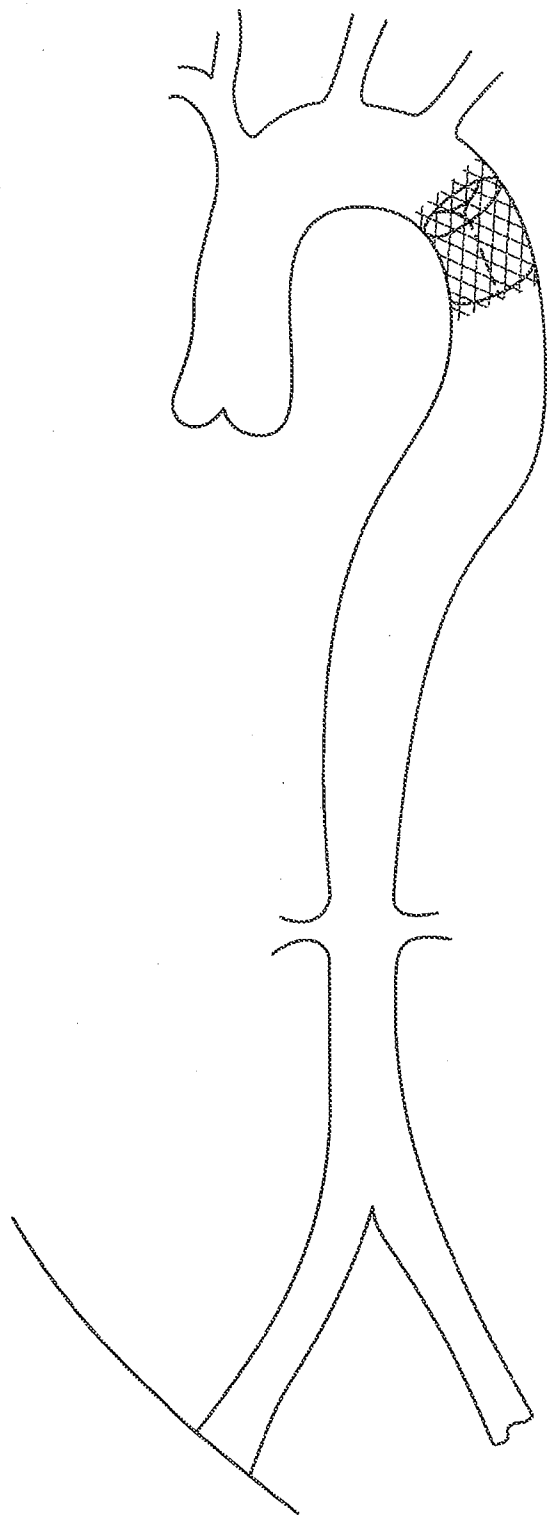

FIG.4

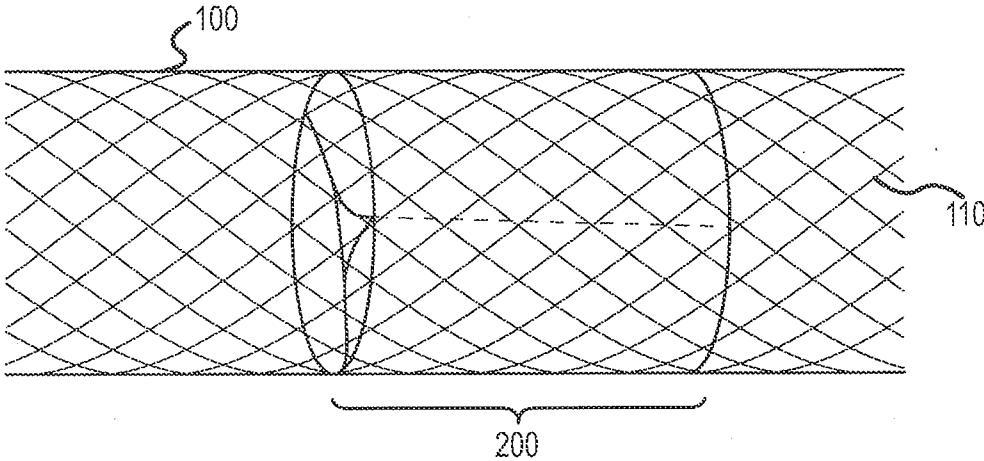

FIG.5

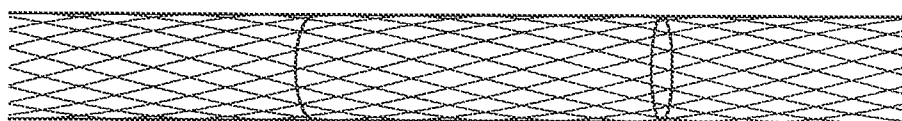

FIG.6

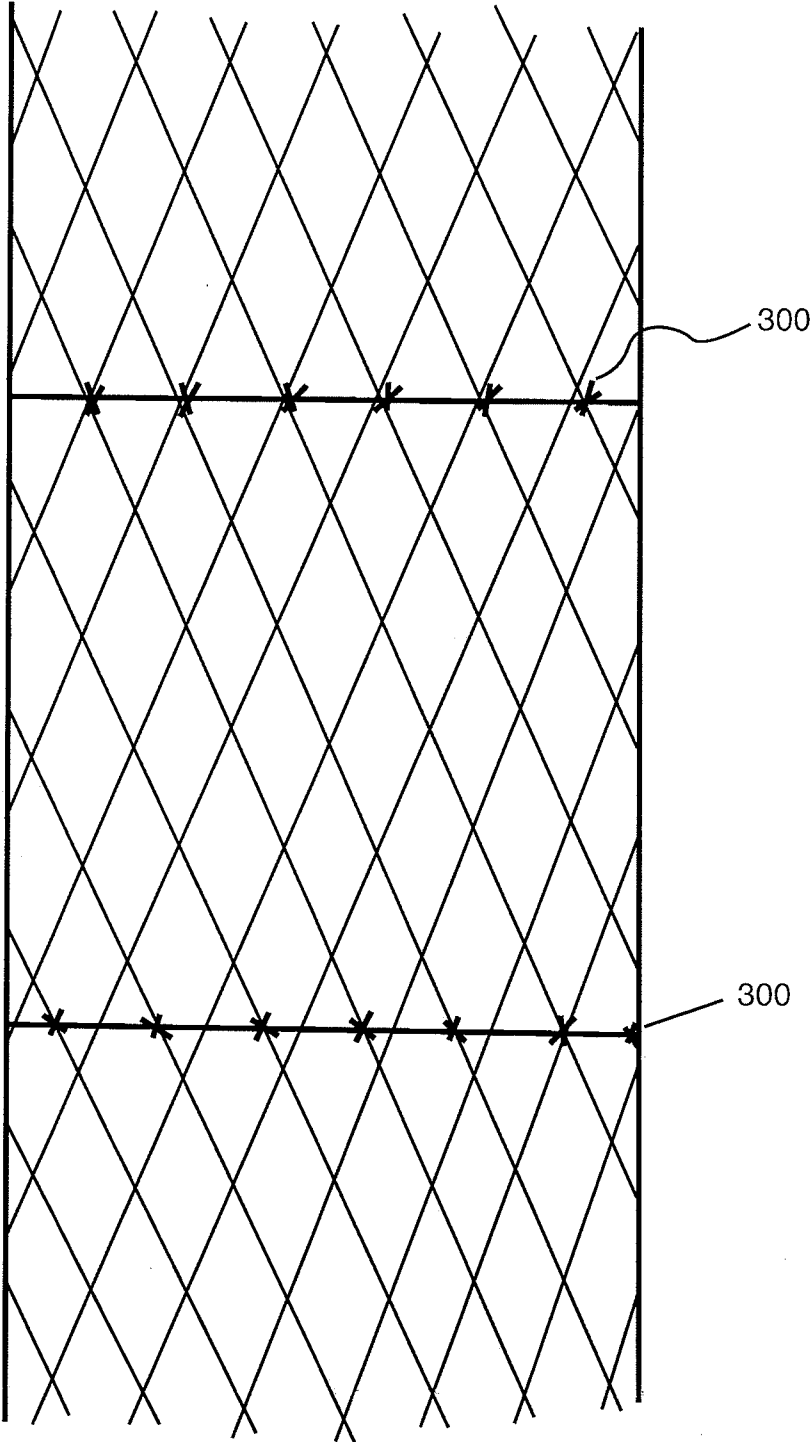

FIG. 7

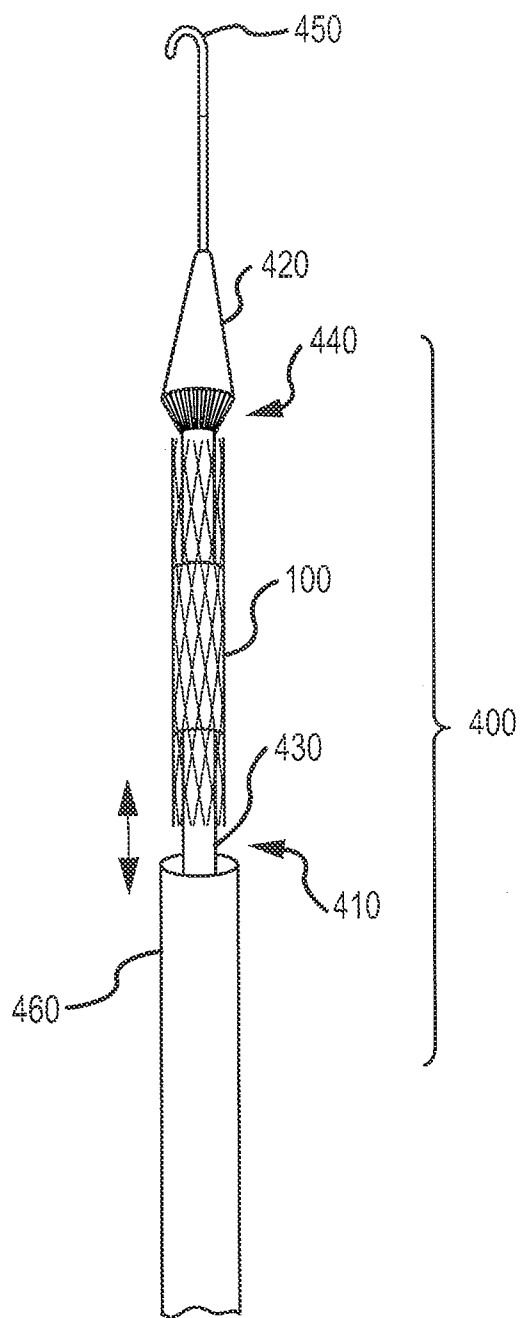

FIG. 8

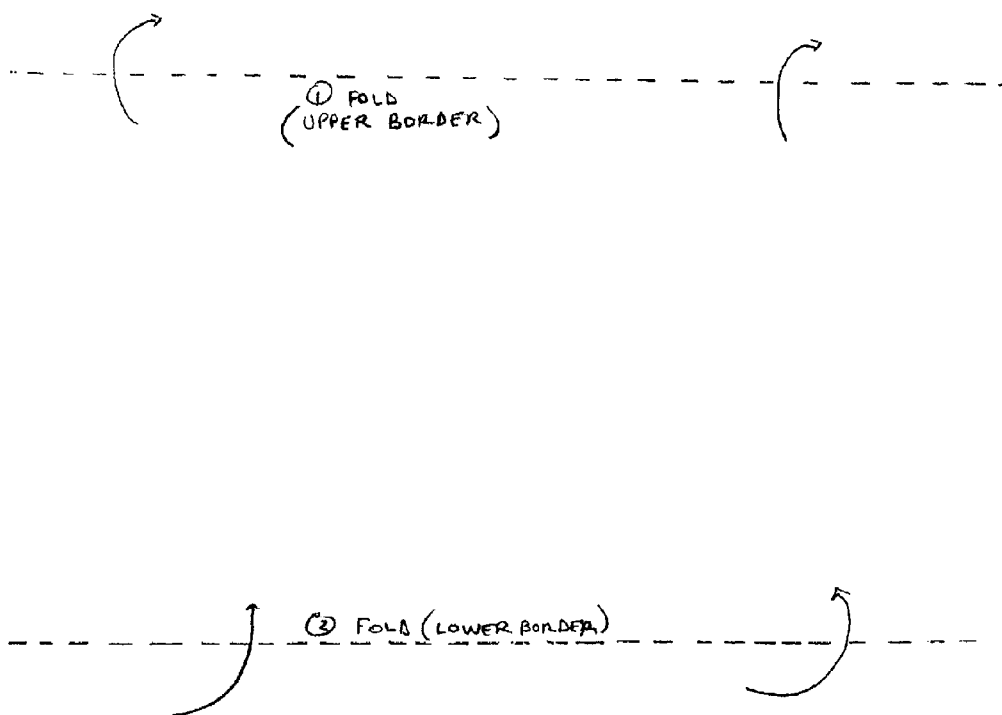

FIG. 9A

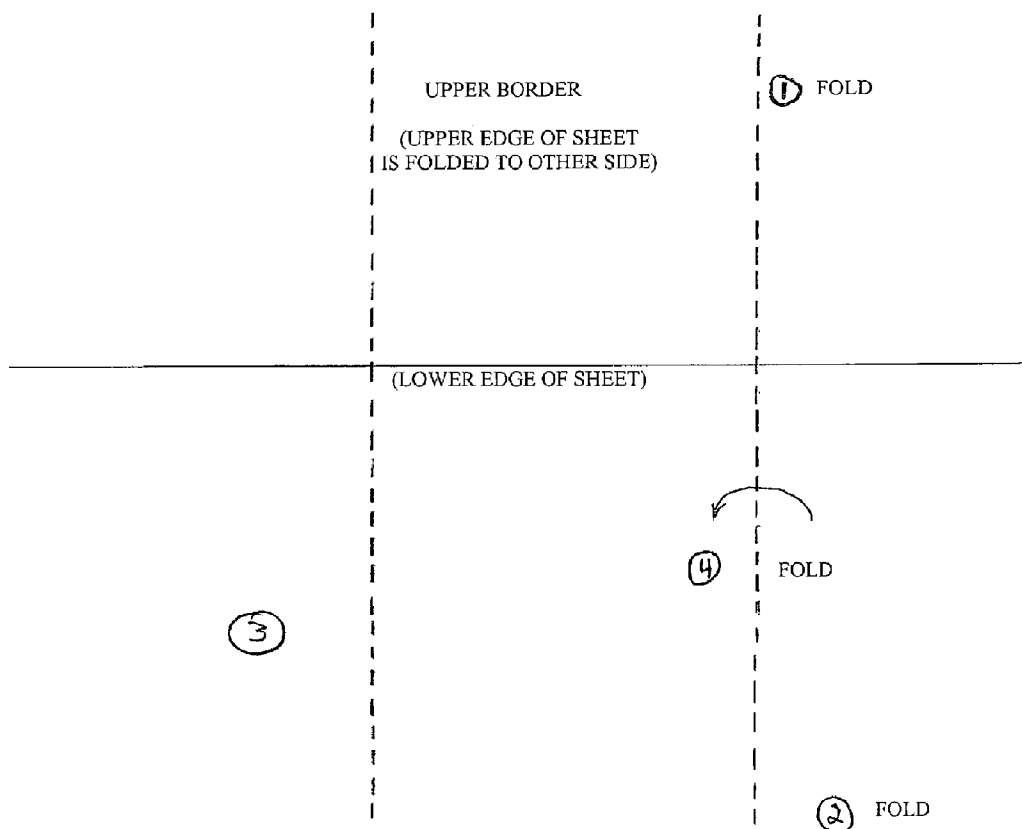

FIG. 9B

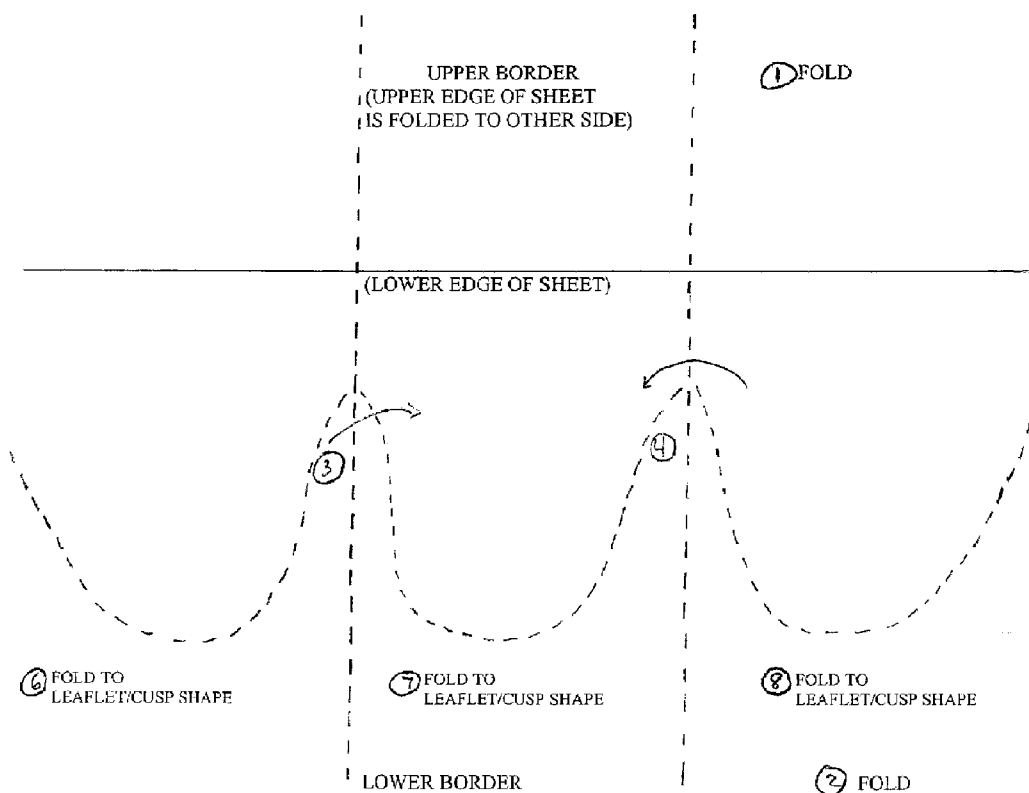

FIG. 9C

**METHOD OF DEPLOYING A
PERCUTANEOUS REPLACEMENT HEART
VALVE**

[0001] The present application is a continuation application of U.S. patent application Ser. No. 13/675,665 filed on Nov. 13, 2012, which is a continuation application of U.S. patent application Ser. No. 10/887,688 filed on Jul. 10, 2004, now U.S. Pat. No. 8,308,797, which is a continuation-in-part application of U.S. patent application Ser. No. 10/037,266, filed on Jan. 4, 2002 (now abandoned). All of the foregoing applications are incorporated herein by reference in their entireties.

BACKGROUND OF THE INVENTION

[0002] 1. Field of the Invention

[0003] The present invention is in the field of heart valve replacement. More specifically, the present invention is directed to a method of making a percutaneously implantable replacement heart valve.

[0004] 2. Description of Related Art

[0005] There have been numerous efforts in the field of heart valve replacement to improve both the durability and effectiveness of replacement heart valves as well as the ease of implantation. A brief description of heart valves and heart function follows to provide relevant background for the present invention.

[0006] There are four valves in the heart that serve to direct the flow of blood through the two sides of the heart in a forward direction. On the left (systemic) side of the heart are: 1) the mitral valve, located between the left atrium and the left ventricle, and 2) the aortic valve, located between the left ventricle and the aorta. These two valves direct oxygenated blood coming from the lungs through the left side of the heart into the aorta for distribution to the body. On the right (pulmonary) side of the heart are: 1) the tricuspid valve, located between the right atrium and the right ventricle, and 2) the pulmonary valve, located between the right ventricle and the pulmonary artery. These two valves direct de-oxygenated blood coming from the body through the right side of the heart into the pulmonary artery for distribution to the lungs, where it again becomes re-oxygenated to begin the circuit anew.

[0007] Heart valves are passive structures that simply open and close in response to differential pressures on either side of the particular valve. They consist of moveable “leaflets” that are designed simply to open and close in response to differential pressures on either side of the valve’s leaflets. The mitral valve has two leaflets and the tricuspid valve has three. The aortic and pulmonary valves are referred to as “semilunar valves” because of the unique appearance of their leaflets, which are more aptly termed “cusps” and are shaped somewhat like a half-moon. The aortic and pulmonary valves each have three cusps.

[0008] In general, the components of heart valves include the valve annulus, which will remain as a roughly circular open ring after the leaflets of a diseased or damaged valve have been removed; leaflets or cusps; papillary muscles which are attached at their bases to the interior surface of the left or right ventricular wall; and multiple chordae tendineae, which couple the valve leaflets or cusps to the papillary muscles. There is no one-to-one chordal connection between the leaflets and the papillary muscles; instead, numerous chordae are present, and chordae from each papillary muscle attach to both of the valve leaflets.

[0009] When the left ventricular wall relaxes so that the ventricular chamber enlarges and draws in blood, the leaflets of the mitral valve separate and the valve opens. Oxygenated blood flows in a downward direction through the valve, to fill the expanding ventricular cavity. Once the left ventricular cavity has filled, the left ventricle contracts, causing a rapid rise in the left ventricular cavity pressure. This causes the mitral valve to close while the aortic valve opens, allowing the oxygenated blood to be ejected from the left ventricle into the aorta. The chordae tendineae of the mitral valve prevent the mitral leaflets from prolapsing back into the left atrium when the left ventricular chamber contracts.

[0010] The three leaflets, chordae tendineae, and papillary muscles of the tricuspid valve function in a similar manner, in response to the filling of the right ventricle and its subsequent contraction. The cusps of the aortic valve also respond passively to pressure differentials between the left ventricle and the aorta. When the left ventricle contracts, the aortic valve cusps open to allow the flow of oxygenated blood from the left ventricle into the aorta. When the left ventricle relaxes, the aortic valve cusps reapproximate to prevent the blood which has entered the aorta from leaking (regurgitating) back into the left ventricle. The pulmonary valve cusps respond passively in the same manner in response to relaxation and contraction of the right ventricle in moving de-oxygenated blood into the pulmonary artery and thence to the lungs for re-oxygenation. Neither of these semilunar valves has associated chordae tendineae or papillary muscles.

[0011] Problems that can develop with heart valves consist of stenosis, in which a valve does not open properly, and/or insufficiency, also called regurgitation, in which a valve does not close properly. In addition to stenosis and insufficiency of heart valves, heart valves may need to be surgically repaired or replaced due to certain types of bacterial or fungal infections in which the valve may continue to function normally, but nevertheless harbors an overgrowth of bacteria (vegetation) on the leaflets of the valve that may embolize and lodge downstream in a vital artery. If such vegetations are on the valves of the left side (i.e., the systemic circulation side) of the heart, embolization may occur, resulting in sudden loss of the blood supply to the affected body organ and immediate malfunction of that organ. The organ most commonly affected by such embolization is the brain, in which case the patient suffers a stroke. Thus, surgical replacement of either the mitral or aortic valve (left-sided heart valves) may be necessary for this problem even though neither stenosis nor insufficiency of either valve is present. Likewise, bacterial or fungal vegetations on the tricuspid valve may embolize to the lungs resulting in a lung abscess and therefore, may require replacement of the tricuspid valve even though no tricuspid valve stenosis or insufficiency is present.

[0012] These problems are treated by surgical repair of valves, although often the valves are too diseased to repair and must be replaced. If a heart valve must be replaced, there are currently several options available, and the choice of a particular type of artificial valve depends on factors such as the location of the valve, the age and other specifics of the patient, and the surgeon’s experiences and preferences. Currently in the United States over 100,000 defective heart valves are replaced annually, at an approximate cost of \$30-50,000 per procedure, and thus it would be desirable if heart valves could be replaced using minimally invasive techniques and without having to repeat the procedure within a matter of years due to the lack of durability of the replacement heart valve. It would

be especially advantageous if a defective heart valve could be removed via an endovascular procedure, that is, a procedure where the invasion into the body is through a blood vessel such as the femoral artery. The procedure is then carried out percutaneously and transluminally using the vascular system to convey appropriate devices to the position in the body wherein it is desired to carry out the desired procedure. An example of such a procedure would be angioplasty, wherein a catheter carrying a small balloon at its distal end is manipulated through the body's vessels to a point where there is a blockage in a vessel. The balloon is expanded to create an opening in the blockage, and then the balloon is deflated and the catheter and balloon are removed from the vessel.

[0013] Endovascular procedures have substantial benefits both from the standpoint of health and safety as well as cost. Such procedures require minimal invasion of the human body, and there is consequently considerable reduction and in some instances even elimination, of the use of a general anesthesia and much shorter hospital stays.

[0014] Replacement heart valves can be categorized as either artificial mechanical valves, transplanted valves and tissue valves. Replacement heart valves are designed to optimize hemodynamic performance, thrombogenicity and durability. Another factor taken into consideration is the relative ease of surgical implantation.

[0015] Mechanical valves are typically constructed from nonbiological materials such as plastics, metals and other artificial materials which, while durable, are expensive and prone to blood clotting which increases the risk of an embolism. Anticoagulants taken to help against blood clotting can further complicate the patient's health due to increased risks for hemorrhages.

[0016] Transplanted valves are natural valves taken from cadavers. These valves are typically removed and frozen in liquid nitrogen, and are stored for later use. They are typically fixed in glutaraldehyde to eliminate antigenicity and are sutured in place, typically with a stent.

[0017] Artificial tissue valves are valves constructed from animal tissue, such as bovine or porcine tissue. Efforts have also been made at using tissue from the patient for which the valve will be constructed.

[0018] Most tissue valves are constructed by sewing the leaflets of pig aortic valves to a stent to hold the leaflets in proper position, or by constructing valve leaflets from the pericardial sac of cows or pigs and sewing them to a stent. The porcine or bovine tissue is chemically treated to alleviate any antigenicity. The pericardium is a membrane that surrounds the heart and isolates it from the rest of the chest wall structures. The pericardium is a thin and very slippery, which makes it difficult for suturing in a millimetrically precise way. The method of making the replacement heart valve of the present invention solves this problem through a process that includes drying and compressing the pericardium using photo-mechanical compression in such a way that makes it possible to handle and fold the material more easily.

[0019] For example, one prior replacement heart valve requires each sculpted leaflet to be trimmed in a way that forms an extended flap, which becomes a relatively narrow strand of tissue near its tip. The tip of each pericardial tissue strand is sutured directly to a papillary muscle, causing the strand to mimic a chordae tendineae. Each strand extends from the center of a leaflet in the valve, and each strand is sutured directly to either an anterior and posterior papillary muscle. This requires each leaflet to be positioned directly

over a papillary muscle. This effectively rotates the leaflets of the valve about 90 degrees as compared to the leaflets of a native valve. The line of commissure between the leaflets, when they are pressed together during systole, will bisect (at a perpendicular angle) an imaginary line that crosses the peaks of the two papillary muscles, instead of lying roughly along that line as occurs in a native valve.

[0020] A different approach to creating artificial tissue valves is described in U.S. Pat. No. 5,163,955 to Calvin, et al. and U.S. Pat. Nos. 5,571,174 and 5,653,749 to Love. Using a cutting die, the pericardial tissue is cut into a carefully defined geometric shape, treated with glutaraldehyde, then clamped in a sandwich-fashion between two stent components. This creates a tri-leaflet valve that resembles an aortic or pulmonary valve, having semilunar-type cusps rather than atrioventricular-type leaflets.

[0021] U.S. Pat. No. 3,671,979 to Mouloupoulos describes an endovascularly inserted conical shaped umbrella-like valve positioned and held in place by an elongated mounting catheter at a supra-annular site to the aortic valve in a nearby arterial vessel. The conical end points toward the malfunctioning aortic valve and the umbrella's distal ends open up against the aorta wall with reverse blood flow, thereby preventing regurgitation.

[0022] U.S. Pat. No. 4,056,854 to Boretos describes an endovascularly inserted, catheter mounted, supra-annular valve in which the circular frame abuts the wall of the artery and attached flaps of flexible membrane extend distally in the vasculature. The flaps lie against the artery wall during forward flow, and close inward towards the central catheter to prevent regurgitation during reverse blood flow. The Boretos valve was designed to be positioned against the artery wall during forward flow, as compared to the mid-center position of the Mouloupoulos valve, to reduce the stagnation of blood flow and consequent thrombus and embolic formation expected from a valve at mid-center position.

[0023] The main advantage of tissue valves is that they do not cause blood clots to form as readily as do the mechanical valves, and therefore, they do not absolutely require systemic anticoagulation. The major disadvantage of tissue valves is that they lack the long-term durability of mechanical valves. Tissue valves have a significant failure rate, usually within ten years following implantation. One cause of these failures is believed to be the chemical treatment of the animal tissue that prevents it from being antigenic to the patient. In addition, the presence of extensive suturing prevents the artificial tissue valve from being anatomically accurate in comparison to a normal heart valve, even in the aortic valve position.

[0024] A shortcoming of prior artificial tissue valves has been the inability to effectively simulate the exact anatomy of a native heart valve. Although transplanted human or porcine aortic valves have the gross appearance of native aortic valves, the fixation process (freezing with liquid nitrogen, and chemical treatment, respectively) alters the histologic characteristics of the valve tissue. Porcine and bovine pericardial valves not only require chemical preparation (usually involving fixation with glutaraldehyde), but the leaflets must be sutured to cloth-covered stents in order to hold the leaflets in position for proper opening and closing of the valve. Additionally, the leaflets of most such tissue valves are constructed by cutting or suturing the tissue material, resulting in leaflets that do not duplicate the form and function of a real valve and are more susceptible to failure.

SUMMARY OF THE INVENTION

[0025] The present invention is a replacement heart valve device and method of making same. The replacement heart valve device, in a preferred embodiment, comprises a stent made of stainless steel or self-expanding nitinol and a completely newly designed artificial biological tissue valve disposed within the inner space of the stent. The cusp or leaflet portion of the valve means is formed by folding of the pericardium material preferably used to create the valve without cutting of slits to form leaflets or suturing or otherwise affixing of separate leaflet portions. Other forms of tissue and suitable synthetic materials can also be used for the valve, formed in a sheet of starting material. The folded design provides a number of advantages over prior designs, including improved resistance to tearing at suture lines. The cusps/leaflets open in response to blood flow in one direction and close in response to blood flow in the opposite direction. Preferably the tubular portion of the valve means contains the same number of cusps as the native valve being replaced, in substantially the same size and configuration. The outer surface of the valve means is attached to the stent member.

[0026] The replacement heart valve device is preferably implanted using a delivery system having a central part which consists of a flexible hollow tube catheter that allows a metallic guide wire to be advanced inside it. The stented valve is collapsed over the central tube and it is covered by a movable sheath. The sheath keeps the stented valve in the collapsed position. Once the cover sheath is moved backwards, the stented valve can be deployed. The endovascular stented-valve, in a preferred embodiment, is a glutaraldehyde fixed mammal pericardium or synthetic biocompatible material which has two or three cusps that open distally to permit unidirectional blood flow. The stent can either be self-expanding or the stent can be expandable through use of a balloon catheter.

[0027] The present invention also comprises a method of making a replacement heart valve device. In order to make the valve, the pericardium starting material is isolated and all the fat tissue and extra fibers are removed. The biological membrane material is cleaned by mechanical separation of unwanted layers using hydromechanical force means. Once the pericardium is completely clean, the material is dried in order to make it easier to handle and fold. Preferably, this drying is done by exposing the biocompatible membrane material to photomechanical compression to remove all lipids from the pericardium or other biocompatible membrane material and to cause protein denaturalization, transforming the material into a stronger and more homogeneous surface. The valve is formed by taking a flat sheet of the material and folding in such a way that forms a three-leaflet or other number of leaflet valve. Then it is placed in a sequence of solutions, one of isopropyl alcohol of about 70-100%, one of ethanol of about 70-100%, one of glycerol and one of glutaraldehyde, preferably at a concentration of about 0.07-25% for approximately 36 hours. The material is dried in order to make it easier to handle and fold. Preferably this drying is done by exposing the biocompatible membrane material to light and then mechanically compressing the material to cause protein denaturation. This results in material that is stronger and more homogeneous. The valve is formed by taking a flat sheet of bovine or porcine pericardium and folding it in such a way that forms a three-leaflet valve. The valve can also be made in the same manner from fresh, cryopreserved or glutaraldehyde fixed allografts or xenografts or

synthetic non-biological, non-thrombogenic material. The folding of the pericardium material to create the cusps or leaflets reduces the extent of suturing otherwise required, and resembles the natural form and function of the valve leaflets. The cleaning, pressing and drying technique used to create the valve material makes the folding more practicable. The valve is rehydrated after being formed. The method of the present invention also greatly reduces the risk of tearing of the cusps or leaflets, since they are formed by folding a single uncut portion of material forming the valve rather than being attached by suturing.

[0028] Once the endovascular implantation of the prosthetic valve device is completed in the host, the function of the prosthetic valve device can be monitored by the same methods as used to monitor valve replacements done by open heart surgery. Routine physical examination, periodic echocardiography or angiography can be performed. In contrast to open heart surgery, however, the host requires a short recovery period and can return home within one day of the endovascular procedure. The replacement heart valve device of the present invention can be used in any patient where bioprosthetic valves are indicated, namely elderly patients with cardiac valve diseases, and patients unable to tolerate open heart procedures or life-long anticoagulation medication and treatment. The present invention can be practiced in applications with respect to each of the heart's valves.

BRIEF DESCRIPTION OF THE DRAWINGS

[0029] FIG. 1 depicts a side perspective view of the replacement heart valve device of the present invention in one embodiment with the valve in the closed position.

[0030] FIG. 2 depicts the folds which form the leaflets or cusps of the replacement heart valve of the present invention in one embodiment.

[0031] FIGS. 3A and 3B depict a preferred procedure for folding the pericardium tissue starting material to create the replacement heart valve of the present invention.

[0032] FIG. 4 depicts a side perspective view of the replacement heart valve device of the present invention in one embodiment represented as if implanted within an artery.

[0033] FIG. 5 depicts a side view of one embodiment of the replacement heart valve device of the present invention mounted within a self-expanding stent, with the stent in the expanded position.

[0034] FIG. 6 depicts a side perspective view of one embodiment of the replacement heart valve device of the present invention mounted within a self-expanding stent in the collapsed position.

[0035] FIG. 7 depicts the suture points of one embodiment of the replacement heart valve device of the present invention.

[0036] FIG. 8 depicts the implantation/delivery system used with the present invention in a preferred embodiment.

[0037] FIGS. 9A, 9B and 9C depict a representation of a sheet of biocompatible valve material showing preferred folds.

DESCRIPTION OF A PREFERRED EMBODIMENT

[0038] The present invention comprises a percutaneously implantable replacement heart valve and a method for making same. The artificial heart valve device of the present invention is capable of exhibiting a variable diameter between a compressed or collapsed position and an expanded position. A

preferred embodiment of the replacement heart valve device according to the present invention is set forth in FIG. 5. The replacement heart valve device comprises a stent member 100 and a flexible valve means 200. The stent member 100 is preferably self-expanding, although balloon-expandable stents can be used as well, and has a first polygonal shape in its compressed or collapsed configuration and a second, larger polygonal shape in its expanded configuration. Referring to FIG. 1, the valve means 200 comprises a generally tubular portion 210 and, preferably, a peripheral upstanding cusp or leaflet portion 220. The valve means 200 is disposed within the cylindrical stent member 100 with the tubular portion 210 transverse of and at some acute angle relative to the stent walls. The diameter of the tubular portion 210 is substantially the same as the inside diameter of the stent member in its initial expanded configuration. The peripheral upstanding cusp or leaflet portion 220 is disposed on valve means 200 substantially parallel to the walls of the stent member similar to a cuff on a shirt. The cusp or leaflet portion 220 of the valve means 200 is generally tubular in shape and comprises three leaflets 221, 222 and 223 as shown, although it is understood that there could be from two to four leaflets. The tubular portion of the valve means 200 is attached to the stent member 100 by a plurality of sutures 300, as depicted in FIG. 7.

[0039] The leaflet portion 220 of the valve means 200 extends across or transverse of the cylindrical stent 100. The leaflets 221, 222 and 223 are the actual valve and allow for one-way flow of blood. The leaflet portion 220 as connected to the rest of the valve resembles the cuff of a shirt. FIG. 9 depicts the folds preferred for valve cusp and leaflet formation involving three leaflets. The configuration of the stent member 100 and the flexible, resilient material of construction allows the valve to collapse into a relatively small cylinder as seen in FIG. 6. The replacement heart valve will not stay in its collapsed configuration without being restrained. Once the restraint is removed, the self-expanding stent member 100 will cause the artificial heart valve to take its expanded configuration, as seen in FIG. 5.

Stent Member

[0040] The stent member 100 preferably comprises a self-expanding nickel-titanium alloy stent, also called "nitinol," in a sine wave-like configuration as shown in FIG. 5. An enlarged view of a preferred embodiment of the stent member for use in the replacement heart valve of the invention is depicted in FIG. 5. The stent member 100 includes a length of wire 110 formed in a closed zigzag configuration. The wire can be a single piece, stamped or extruded, or it could be formed by welding the free ends together. The straight sections of the stent member 100 are joined by bends. The stent is readily compressible to a small cylindrical shape as depicted in FIGS. 6 and 8, and resiliently self-expandable to the shape shown in FIG. 5.

[0041] The stent member 100 of the artificial heart valve device of the present invention may be made from various metal alloys, titanium, titanium alloy, nitinol, stainless steel, or other resilient, flexible non-toxic, non-thrombogenic, physiologically acceptable and biocompatible materials. The configuration may be the zigzag configuration shown or a sine wave configuration, mesh configuration or a similar configuration which will allow the stent to be readily collapsible and self-expandable. When a zigzag or sine wave configured stent member is used, the diameter of the wire from which the stent

is made is preferably from about 0.010 to 0.035 inches and still, preferably from about 0.012 to 0.025 inches. The diameter of the stent member will be from about 1.5 to 3.5 cm, preferably from about 1.75 to 3.00 cm, and the length of the stent member will be from about 1.0 to 10 cm, preferably from about 1.1 to 5 cm.

[0042] The stent used in a preferred embodiment of the present invention is fabricated from a "shaped memory" alloy, nitinol, which is composed of nickel and titanium. Nitinol wire is first fashioned into the desired shape for the device and then the device is heat annealed. A meshwork of nitinol wire of approximately 0.008 inch gauge is formed into a tubular structure with a minimum central diameter of 20 mm to make the stent. Away from its central portion, the tubular structure flares markedly at both ends in a trumpet-like configuration. The maximum diameter of the flared ends of the stent is approximately 50 mm. The purpose of the stent is to maintain a semi-rigid patent channel through the diseased cardiac valve following its implantation.

[0043] When the components of the replacement heart valve device are exposed to cold temperatures, they become very flexible and supple, allowing them to be compressed down and pass easily through the delivery sheath. A cold temperature is maintained within the sheath during delivery to the deployment site by constantly infusing the sheath with an iced saline solution. Once the valve components are exposed to body temperature at the end of the sheath, they instantaneously reassume their predetermined shapes, thus allowing them to function as designed.

[0044] Preferably the stent member 100 carries a plurality of barbs extending outwardly from the outside surface of the stent member for fixing the heart valve device in a desired position. More preferably the barbs are disposed in two spaced-apart, circular configurations with the barbs in one circle extending in an upstream direction and the barbs in the other circle extending in a downstream direction. It is especially preferable that the barbs on the inflow side of the valve point in the direction of flow and the barbs on the outflow side point in the direction opposite to flow. It is preferred that the stent be formed of titanium alloy wire or other flexible, relatively rigid, physiologically acceptable material arranged in a closed zigzag configuration so that the stent member will readily collapse and expand as pressure is applied and released, respectively.

Valve Means

[0045] The valve means 200 is flexible, compressible, host-compatible, and non-thrombogenic. The valve means 200 can be made from various materials, for example, fresh, cryopreserved or glutaraldehyde fixed allografts or xenografts. Synthetic biocompatible materials such as polytetrafluoroethylene, polyester, polyurethane, nitinol or other alloy/metal foil sheet material and the like may be used. The preferred material for the valve means 200 is mammal pericardium tissue, particularly juvenile-age animal pericardium tissue. The valve means 200 is disposed within the cylindrical stent member 100 with the tubular portion 210 transverse of and at some acute angle relative to the stent walls. The diameter of the tubular portion 210 is substantially the same as the inside diameter of the stent member 100 in its initial expanded configuration. The peripheral upstanding cusp or leaflet portion 220 is disposed substantially parallel to the walls of the stent member 100 similar to a cuff on a shirt.

[0046] The cusp or leaflet portion **220** of the valve means **200** is formed by folding of the pericardium material used to create the valve. FIGS. **3A** and **3B** depict the way the sheet of heart valve starting material is folded. The starting material is preferably a flat dry sheet, which can be rectangular or other shaped. The cusps/leaflets **221**, **222** and **223** open in response to blood flow in one direction and close in response to blood flow in the opposite direction. Preferably the cusp or leaflet portion **220** of the valve means **200** contains the same number of cusps as the native valve being replaced, in substantially the same size and configuration. FIGS. **9A-9C** depict a preferred configuration for folds to create the leaflets/cusps. The leaflet forming portion is a single, continuous, uncut layer affixed to the interior of the cuff layer to form the leaflets/cusps, unlike prior efforts that have involved suturing of three separate leaflet/cusp portions onto the main valve body portion. The leaflets are formed from the free edge of the material after forming the cuff portion. Referring now to FIGS. **9A**, **9B**, and **9C**, with flat sheet on a table, a person facing the sheet would create a cuff at the upper border of sheet by folding the horizontal top edge away/downwardly (fold no. **1**). The leaflet portion is formed by folding the sheet's lower half towards the folder/upwardly, as shown in FIG. **9A** (fold no. **2**). The sheet, now with the upper cuff and bottom inward fold, is folded inwardly at two preferably equidistant vertical points as shown in FIG. **9B** to create the leaflet/cusp portion (folds nos. **3** and **4**). The leaflets/cusps are formed by folding fold nos. **6**, **7** and **8** after the two opposite vertical edges of sheet are joined to create a cylindrical valve shape, depicted in FIGS. **1** and **3B**. The inner leaflet layer is preferably attached to the outer cuff layer by curved or straight continuous suturing. Although a preferred embodiment of the invention comprises a single piece of valve material folded to create the valve body and a leaflet-forming portion that has no cuts or sutures, the inventors have discovered that as long as the leaflet portion of the valve itself is formed from a single piece of biocompatible valve material, the other portions of the valve can be formed by suturing of one or more separate pieces of material without losing the novel and improved qualities of the present invention. This allows for the valve to be made even stronger, more durable and easier to make. This alternate embodiment comprises a leaflet forming layer made of a single piece of valve material attached to a separate piece forming the valve body having a folded cuff portion. The single piece leaflet forming layer is preferably cylindrical in shape and can be formed with or without folding. In this embodiment the single piece leaflet layer can itself be attached to the stent with or without a cylindrical cuff portion. Attachment is preferably by suturing, particularly continuous single or double sutures.

Method of Making Replacement Heart Valve Device

[0047] The present invention also comprises a method of making a replacement heart valve device. In order to make the valve, the biocompatible tissue material is isolated and all the fat tissue and extra fibers are removed. Cleaning is preferably accomplished by using a hydromechanical force-based cleaning device to separate tissue layers and hydration with distilled water to remove unwanted layers. Once the pericardium is completely clean, it is subjected to photo-mechanical compression, then the valve is formed and placed in sequential solutions of isopropyl alcohol of about 70-100%, ethanol of about 70-100%, glycerol and glutaraldehyde preferably at a concentration of about 0.07-25% for about 36 hours, respectively. The material is preferably photomechanically com-

pressed to remove lipids and produce protein coagulation to make the surface smoother and more compact and biocompatible, decreasing the molecular distance of collagen fibers. The exposure to light and mechanical compression cause protein denaturation making the material stronger and more homogeneous and biocompatible. Gas sterilization can also be used to sterilize the tissue membrane material. The valve is formed by taking a flat sheet of the material and folding it in such a way that forms a three-leaflet or desired number of leaflet valve as shown in FIGS. **3A** and **3B** and/or FIGS. **9A**, **9B** and **9C**. The folding of the pericardium material to create the cusps or leaflets reduces the extent of suturing otherwise required, and resembles the natural form and function of the valve leaflets. It also greatly reduces the risk of tearing of the cusps or leaflets, since they are integral to the valve rather than being attached by suturing.

[0048] In a preferred embodiment, the single continuous piece of membrane is folded inward to form an inner leaflet layer within the outer cuff. The single leaflet layer is then attached to the cuff layer to form valve cusps in one of three preferred ways: (i) by curved or straight continuous single or double sutures that affix and form the bases or recesses of the valve cusps; (ii) by lengthwise suture lines attaching the leaflet layer to the cuff layer with the bases or recesses of the valve cusps being thus formed of the folded edge of the membrane; (iii) by further folding of the membrane into lengthwise pleats secured by lengthwise suture attaching the leaflet layer to the cuff layer with the bases or recesses of the valve cusps being thus formed of the folded edge of the membrane, done for the purpose of giving greater strength and durability to the attachment points of the leaflet layer.

[0049] In order to make the pericardium material less slippery and easier to fold, the pericardium is dried, preferably with artificial light using a multi-watt lamp with the pericardium or other biocompatible membrane material placed in a flat aluminum surface to dry it homogeneously. A photomechanical drying machine can also be used. The final result is a homogeneous tissue that looks like plastic paper and makes it easy to manipulate to fold and suture the valve. Once the valve is formed, it is re-hydrated by placing it in a solution of water and 70% alcohol. In approximately 3 days the valve is fully rehydrated. The suturing of membrane layers to form the valve is done with single, double, or more continuous suture material. This form of suturing has great advantages for durability and avoidance of damage to the membrane and can be performed by sewing machines. The attachment points of the leaflet layer to the cuff layer may be reinforced by folding an additional layer of membrane over the attachment point before suturing, this layer being formed of a projected tab of the continuous piece of leaflet membrane. The free edge of the leaflet layer may be straight or curved, and this free edge forming the free edges of the individual leaflets may be contoured in parabolic or curved shape.

Attachment of the Valve Means to the Stent Member

[0050] The valve means **200** is then attached to the inner channel of the stent member **100** by suturing the outer surface of the valve means' pericardium material to the stent member. FIG. **7** depicts preferred suture points of one embodiment of the present invention: 3-point fixation or 6-point fixation at each border of the stent. Other fixation schemes can be utilized, such as, by way of non-limiting example, fixation on both borders 18 points at each end following a single plane and 36 fixation points following to adjacent vertical planes.

The use of only one plane of fixation points helps prevent systolic collapse of the proximal edge of the valve means. A fold on the border of the pericardium material prevents tearing. The attachment position of the valve is preferably closer to the proximal and wider part of the stent.

[0051] The sequence of steps can vary. The pericardium material can be fixed in glutaraldehyde before attachment to the stent or the valve can be formed and then fixed with glutaraldehyde after mounting it in the stent. One observation noted is that the material becomes whiter and apparently increases its elasticity. 1 mm vascular clips keep the cusps coapted while fixing them in glutaraldehyde. The use of metallic clips to keep both cusps adjacent to each other after 24 hours of fixation in glutaraldehyde helps to educate the material and make the primary position of the valve cusps adjacent to each other. After the clips are removed, there are no lesions to the valve.

[0052] Different suture materials can be used, including, in a preferred embodiment, Prolene 1-0 to 8-0 and Mersilene 1-0 to 8-0 which is a braided suture.

Implantation of Replacement Heart Valve Device

[0053] The replacement heart valve device of the present invention is preferably used in surgical procedures involving the percutaneous and transluminal removal of the diseased or defective heart valve and the percutaneous and transluminal implantation of the new heart valve described above. The defective heart valve is removed by a suitable modality, such as, for example, laser, ultrasound, mechanical, or other suitable forms of delivery of energy, or phacoemulsion, including, but not limited to, laser lithotripsy, mechanical lithotripsy, electrohydraulic lithotripsy, and laser or mechanical ablation. To remove the native heart valve that is being replaced, a guidewire is inserted percutaneously and transluminally using standard vascular or angiography techniques. The distal end of the guidewire is manipulated to extend through and across the defective heart valve. Then a catheter is advanced distally through the femoral artery to a point proximal to the defective heart valve, between the origin of the coronary artery and the origin of the right subclavian artery. The position of the distal end of catheter can be monitored by observation of radiopaque markers. Collector member is preferably inflated and occludes the aorta at a point between the origin of the coronary artery and the right subclavian artery. Next, a balloon and cutting tool are advanced through the catheter so that the cutting tool and uninflated balloon are distal to the defective heart valve. Optionally an additional step, such as balloon dilatation or atherectomy, may be required to provide a passageway through the heart valve. A catheter is also placed into the coronary sinus via a transjugular puncture. This catheter is used for infusion of blood or cardioplegia solution during the portion of the procedure when the aorta is occluded. The absence of valves in the cardiac venous system allows retrograde flow so that there will be an effluence of fluid from the coronary arteries. This flow of fluid is desired to prevent embolization of material into the coronary arteries during the procedure. Once the cutting tool is in place, the balloon is inflated and flexible shaft is rotated. Once the cutting tool has reached the appropriate rotation speed, the cutting tool is pulled proximally to remove the defective heart valve. The balloon and the cutting tool are spaced apart so that the inflated balloon will be stopped by the perimeter, unremoved portion of the defective heart valve, which will signal the physician that the valve has

been removed, as well as protect the heart and aorta from damage from the valve removal device. Once it is determined that the defective heart valve has been removed, the cutting tool is slowed or stopped altogether and the balloon is deflated. The cutting tool and the deflated balloon are pulled proximally through catheter. Then, a catheter containing an artificial heart valve is inserted and the artificial heart valve is placed as described above.

[0054] The delivery and implantation system of the replacement artificial heart valve of the present invention percutaneously and transluminally includes a flexible catheter **400** which may be inserted into a vessel of the patient and moved within that vessel as depicted in FIG. **8**. The distal end **410** of the catheter **400**, which is hollow and carries the replacement heart valve device of the present invention in its collapsed configuration, is guided to a site where it is desired to implant the replacement heart valve. The catheter has a pusher member **420** disposed within the catheter lumen **430** and extending from the proximal end **440** of the catheter to the hollow section at the distal end **410** of the catheter. Once the distal end **410** of the catheter is positioned as desired, the pusher mechanism **420** is activated and the distal portion of the replacement heart valve device is pushed out of the catheter and the stent member **100** partially expands. In this position the stent member **100** is restrained so that it doesn't pop out and is held for controlled release, with the potential that the replacement heart valve device can be recovered if there is a problem with the positioning. The catheter **400** is then retracted slightly and the replacement heart valve device is completely pushed out of the catheter **400** and released from the catheter to allow the stent member **100** to fully expand. If the stent member **100** preferably includes two circles of barbs on its outer surface as previously described, the first push and retraction will set one circle of barbs in adjacent tissue and the second push and release of the replacement heart valve device will set the other circle of barbs in adjacent tissue and securely fix the replacement heart valve device in place when the device is released from the catheter.

[0055] Alternatively, or in combination with the above, the replacement heart valve device could be positioned over a metallic guidewire that is advanced through the catheter. The replacement heart valve device of the present invention is preferably implanted percutaneously through an aortic passageway to, or near to, the location from which the natural heart valve has been removed. Referring to FIG. **8**, the implantation system comprises a flexible hollow tube catheter **410** with a metallic guide wire **450** disposed within it. The stented valve device is collapsed over the tube and is covered by a moveable sheath **460**. The moveable sheath **460** maintains the stented valve device in the collapsed position. The implantation method comprises the following steps: inserting the replacement heart valve device in the lumen of a central blood vessel via entry through the brachial or femoral artery using a needle or exposing the artery surgically; placing a guide wire **450** through the entry vessel and advancing it to the desired position; advancing dilators over the wire to increase the lumen of the entry site, thereby preparing the artery to receive the heart-valve; and advancing the heart-valve device to the desired place. The stented-valve device is released by pulling the cover sheath **460** of the delivery system allowing the self-expanding stent to achieve its full expansion. A balloon expandable stent can alternately be used to deliver the valve to its desired position. At this point, a

pigtail catheter is advanced over the wire and an aortogram is performed to assess the competency of the valve.

[0056] Before creation of the valve means and implantation, the patient is studied to determine the architecture of the patient's heart. Useful techniques include fluoroscopy, transesophageal echocardiography, MRI, and angiography. The results of this study will enable the physician to determine the appropriate size for the replacement heart valve.

[0057] In one procedure for implantation of the replacement heart valve device of the present invention, the femoral artery of the patient is cannulated using a Cook needle and a standard J wire is advanced into the artery either percutaneously or after surgical exposure of the artery. An 8 F introducer is advanced into the femoral artery over the wire. The J wire is then withdrawn and anticoagulation is started using heparin 60 U/Kg intravenously. Once vascular access is obtained an aortogram is performed for anatomical evaluation. A special wire (Lunderquist or Amplatz superstiff) is advanced into the aortic arch and dilators progressively larger are advanced over the wire, starting with 12 F all the way to 18 F. After this the valve introducer device containing the prosthetic valve device is then inserted and used to transport the replacement valve over a guidewire to the desired position. The stented-valve is released by pulling the cover sheath of the delivery system allowing the self-expanding stent to achieve its full expansion. At this point, a pigtail catheter is advanced over the wire and repeat aortogram is performed to assess the competency of the valve.

[0058] When the device is used to treat severe leakage of the aortic valve, the native valve is left in place and the prosthetic stented valve is deployed below the subclavian artery. When the device is used to treat aortic stenosis, first the stenotic valve needs to be opened using either aortic valvuloplasty or cutting and if this procedure induces aortic insufficiency the stented valve is placed to prevent the regurgitation.

[0059] Intravascular ultrasound or an angioscope passed intravascularly via either the venous system through the intra-atrial septum across the mitral valve and into the left ventricle or retrograde via the femoral artery would provide the added benefit of allowing constant high definition imaging of the entire procedure and high flow irrigation.

[0060] Once the endovascular implantation of the prosthetic valve device is completed in the host, the function of the prosthetic valve device can be monitored by the same methods as used to monitor valve replacements done by open heart surgery. Routine physical examination, periodic echocardiography or angiography can be performed. In contrast to open heart surgery, however, the host requires a short recovery period and can return home within one day of the endovascular procedure. The prosthetic valve device can be used in any patient where bioprosthetic valves are indicated, namely elderly patients with cardiac valve diseases, and patients unable to tolerate open heart procedures or life-long anticoagulation. In addition, with the development of longer-life, flexible, non-thrombogenic synthetic valve alternatives to bioprostheses, the prosthetic valve device will be indicated in all patients where the relative advantages of the life-span, the non-thrombogenic quality, and the ease of insertion of prosthetic valve devices outweigh the disadvantages of mechanical valves. Anticoagulation may be beneficial in certain clinical situations for either short or long term use.

[0061] This method of percutaneous endovascular heart-valve replacement, in contrast to open heart surgical proce-

dures, requires only local anesthesia, partial or no cardiac bypass, one to two days hospitalization, and should result in a reduced mortality rate as compared to open heart procedures.

[0062] While the present invention has been shown and described herein in what is considered to be a preferred embodiment thereof, illustrating the results and advantages over the prior art obtained through the present invention, the invention is not limited to the specific embodiments described above. Thus, the forms of the invention shown and described herein are to be taken as illustrative and other embodiments may be selected without departing from the spirit and scope of the present invention.

1.-33. (canceled)

34. A method of deploying a percutaneous replacement heart valve in a patient where a bioprosthetic heart valve is indicated, comprising:

providing a replacement heart valve device and a delivery and implantation system:

the replacement heart valve device including:

a stent member that is collapsible, expandable and configured for percutaneous delivery; and

a valve attached to the stent member, the valve including two to four individual leaflets;

the delivery and implantation system including:

a balloon catheter and a moveable sheath, wherein the balloon catheter includes a lumen for receiving a guide wire, wherein the moveable sheath includes a lumen configured for receiving the balloon catheter, and wherein the replacement heart valve device is collapsed onto the balloon catheter to reside in a collapsed configuration on the balloon catheter and is restrained in a collapsed configuration by the moveable sheath;

after the providing step, guiding the delivery and implantation system over the guide wire within the patient to position the replacement heart valve device for deployment within the patient, wherein the replacement heart valve device remains collapsed onto the balloon catheter and continues to be restrained in the collapsed configuration by the moveable sheath;

after the guiding step, partially deploying a distal portion of the replacement heart valve device within the patient by partially exposing the replacement heart valve device from the moveable sheath;

after the partially deploying step, restraining the replacement heart valve device so that it does not pop out and is held for controlled release, with a potential that the replacement heart valve device can be recovered if there is a problem with positioning; and

after the restraining step, the replacement heart valve device is at the desired position, slightly retracting the moveable sheath to release the replacement heart valve device from the moveable sheath to allow the replacement heart valve device to fully expand.

35. The method of claim 34, wherein partially exposing the replacement heart valve device from the moveable sheath comprises pushing out the balloon catheter from the moveable sheath to expose a portion of the replacement heart valve device from the moveable sheath.

36. The method of claim 34, wherein partially exposing the replacement heart valve device from the moveable sheath

comprises pulling back the moveable sheath to expose a portion of the replacement heart valve device from the moveable sheath.

37. The method of claim 34, wherein the guiding step is done transluminally.

38. The method of claim 37, wherein the guiding step is done transluminally over the guide wire.

39. The method of claim 34, further comprising using an introducer for receiving the moveable sheath.

40. The method of claim 34, wherein the stent member is self-expanding.

41. The method of claim 40, wherein the stent member comprises nitinol.

42. The method of claim 34, wherein constant high definition imaging is conducted after the providing step.

43. The method of claim 42, wherein the constant high definition imaging includes using intravascular ultrasound.

44. The method of claim 42, wherein the constant high definition imaging includes using an angioscope.

45. The method of claim 34, wherein after the replacement heart valve device is fully expanded, monitoring of the replacement heart valve device is performed.

46. The method of claim 45, wherein the monitoring comprises echocardiography.

47. The method of claim 45, wherein the monitoring comprises angiography.

* * * * *