

Oct. 23, 1962

E. J. SWIMMER ETAL

3,059,617

PENCIL SHARPENER

Filed June 20, 1961

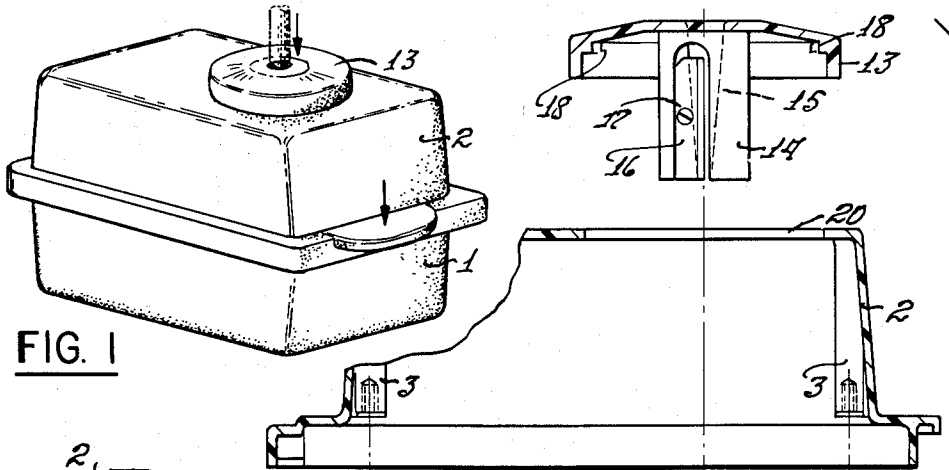

FIG. 1

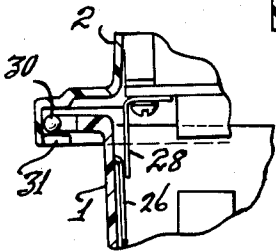

FIG. 3

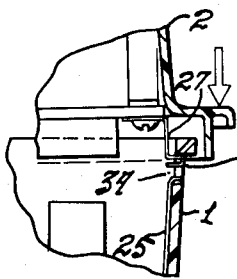

FIG. 4

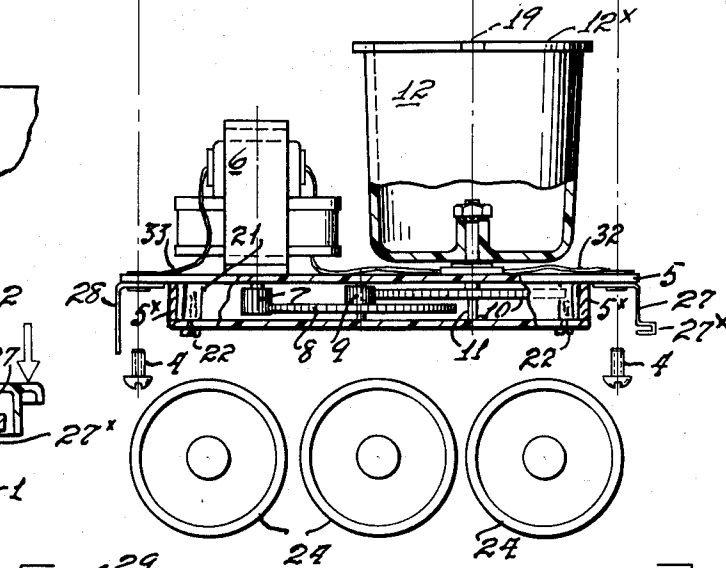

FIG. 2

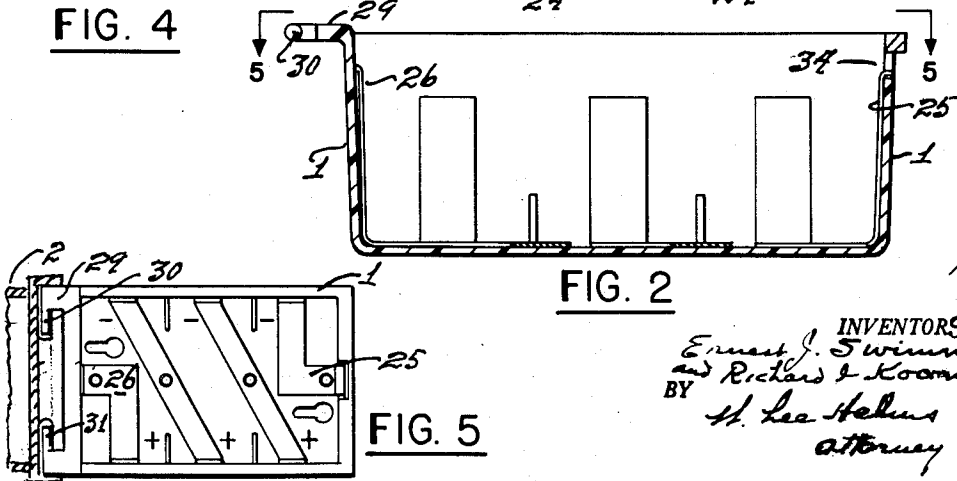

FIG. 5

INVENTORS
Ernest J. Swimmer
and Richard L. Koomtz
BY
H. Lee Helms
Attorney

1

3,059,617

PENCIL SHARPENER

Ernest J. Swimmer, 229 E. 53rd St., New York, N.Y.,
and Richard I. Koontz, Thompson Road, East Syracuse,
N.Y.

Filed June 20, 1961, Ser. No. 128,613

2 Claims. (Cl. 120-96)

The object of the present invention is to provide a compact and simplified pencil sharpener for operation by a plurality of dry cell batteries, the improvement being characterized by the formation of the casing including a base member holding the dry cell batteries and strip conductors, and a cover member which encloses not only the operating parts, including a motor drive, but which embodies a spring contact member leading to the motor circuit which normally holds the cover member slightly inclined, slight downward movement of the cover member serving to bring a second contact member thereof into circuit closing position, i.e. in contact with strip conductor of the base member.

The invention will be described with reference to the accompanying drawings, in which:

FIG. 1 is a perspective view showing an embodiment of the invention with a pencil section in position for sharpening;

FIG. 2 is a composite view partly in vertical section and partly broken away showing all of the members of the assembly in their proper position for placement in the base and cover members of the casing;

FIG. 3 is a fragmentary view in vertical section showing the spring engaged end of the casing, the spring action being performed by strip conductors in the circuit;

FIG. 4 is a view similar to FIG. 3 showing the opposite end of the casing, the use of an upper strip conductor as a latch for the cover and the movement of the cover (indicated by an arrow) to bring the latch-conductor strip into contact with a strip conductor in the base member for completing the circuit;

FIG. 5 is a top plan view of the casing base member showing the battery cell strip contacts therein.

Referring to the drawings, we have shown at 1 the base member of a casing, and at 2 the cover member therefor. The cover member carries opposed depending post 3 having threaded apertures for screws 4 passing through a plate 5, on the top of which is supported any suitable electric motor 6. The shaft of the motor passes through plate 5 and carries a drive gear 7 in mesh with gears 8, 9 and 10, the latter gear being on a shaft 11 which passes upwardly through plate 5 and is fixed in any suitable manner to a rotated cup 12 adapted to receive shavings from pencils which are sharpened by the device.

Cup 12 rotates with a cap thereon, the cap being shown at 13. Cap 13 carries a depending block 14, the cap and block being apertured as indicated by the dotted lines 15 to receive a pencil for engagement with a sharpening blade 16, held in a recess of block 14 by a screw 17. It is preferred that cap 13 be frictionally held on cup 12, but held against rotation on the cup by lugs 18 which enter apertures at the rim 12^x of the cup, one of said apertures being shown at 19, FIG. 2. Cover member 2 is formed with a top aperture at 20, through which the upper area of cup 12 may pass to receive the exposed cap 13 of the cup.

As hereinbefore stated, all of the sharpening and drive elements are carried by plate 5 for reception within the cover member 2 of the casing, and plate 5 is secured to the cover member by two screws shown at 4. Plate 5 has a depending rim at 5^x, and the plate also is provided with a suitable number of depending posts 21

2

to receive screws 22 which pass through a bottom cover 23. Thus the drive gears are completely enclosed.

The base member 1 of the casing serves as a battery box as well as a stand for a device, and in the present embodiment member 1 carries three dry cell batteries indicated at 24 for the battery contacting circuit strips shown in FIG. 5, of which the end strips 25 and 26 have a special function in co-action with contact strips 27 and 28 within cover member 2.

As shown in FIGURES 2, 3 and 5, the base member 1 of the casing is formed with outwardly projecting lugs 29, having inwardly directed pintles 30 to interengage an interfitting pintle arrangement at 31 carried by the cover. Thus when the said cover 2 is moved to vertical position its pintle arrangement 31 may be moved upwardly, the position shown in FIG. 5, and when the cover is swung down horizontally the pintle arrangement 31 will move under the pintles 30 of the base member, and cover member will be hinged at one end and ready for latching at the opposite end.

Cover members normally held in inclined position under spring action, contact strip 28, FIG. 3 being the spring member. At the opposite end of the assembly within the cover member strip contact member 27 is electrically connected to the motor by wire 32, and strip 27 at its end is bent to form a nose at 27^x. The circuit through the motor is completed by wire 33 leading to spring contact member 28. Like contact 28, its co-acting contact 27 has spring action. Thus when cover member 2 is applied to base member 25, contact member 27 removed inwardly over the inner edge of base member 1 will snap into an aperture in the wall of member 1 as indicated at 34, FIGS. 2 and 4.

Referring to FIG. 4, it will be seen that the cover member 2, because of its normal inclination, holds contact nose 27^x out of engagement with the outwardly bent end of contact strip 25, but that when the cover member is pressed downwardly in the direction of the arrow, FIG. 4, contact will be made and the circuit closed.

By means of the invention the casing members may be molded of plastic, and the blade carrying cap for the cup which receives pencil shavings may be rigidly held by the cup. Furthermore, the entire mechanism supporting cover member is hinged at one end, and is spring impelled to assume a normal inclined position by contact strip acting as a spring, whereas at the opposite end of the cover member a contact strip acts as a latch. Assembly and disassembly of the cover member is very simple, the disassembly merely requires a pull upward at the latch holding end and movement of the cover member to vertical position as shown in FIG. 5, at 2, whereupon the pintle arrangement of the cover can be dropped downward out of engagement with the pintles 30 of the base member. By reverse action the cover may be reassembled on the base member. Also, it will be seen that a movement upward of the cover member on its pintle hinge will enable quick replacement of batteries, since the base member is wholly exposed and the batteries have placement side by side.

Having described our invention, what we claim and desire to secure by Letters Patent, is as follows:

1. A pencil sharpener consisting of a casing comprising a base member in open-top box-like form, the base member being adapted to receive a plurality of dry cell batteries, conductor strips held within the base member at its sides and bottom, the two outermost contact strips extending upwardly at the ends of said base member, the upward extension of one contact strip ending at a point adjacent an aperture in a wall of the base member, in combination with an apertured cover member for said base member, an electric motor having a shaft and drive gear, a rotary cup in registration with the

cover aperture, the cup having a shaft and driven gear thereon, an apertured cap for the cup and a blade carried thereby, gear connections between the first named gears, the motor, shafts, gears, and rotary cup being carried by the cover member, a depending spring contact finger carried at one end of the cover, a depending spring contact member carried by the opposite end of the cover, wiring between said contact members and the motor, the second contact member having a nose adapted to snap in said aperture in the wall of the base member, and the first named contact member being adapted to spring engage an upwardly extended contact strip of the base member, and to normally hold the cover member in inclined position, with said second contact member, as to its nose, in uppermost position relative to said wall slot in the base member, downward pressure on the plate bridging the contacts and closing the circuit through the motor.

2. In a pencil sharpener consisting of casing comprising a base member adapted to receive a plurality of dry cell batteries and a cover therefor, characterized by means holding the cover member in such manner that it may be depressed from a normal position, in combination with conductor strips within the base member and adapted for contact with such batteries, said

conductor strips within the base member including two spaced contact strips extending upwardly at the ends of the base member, an electric motor in the cover member and having a shaft and driven gear, a rotary cup extending through the top of the cover member and operatively connected with said driven gear of the motor, an apertured cap for the cup and a blade carried thereby, a depending spring contact member carried at one end of the cover and adapted for engagement with one of the contact strips extending upwardly from the base member, a second depending contact member carried by the cover, wiring between said two contact members of the cover and the motor, downward pressure on the cover member toward the base being adapted to close the circuit through the motor by completing the mutual engagement of the cover and base contact strips.

References Cited in the file of this patent

UNITED STATES PATENTS

20	2,189,476	Siggelko	Feb. 6, 1940
	3,004,522	Kent	Oct. 17, 1961

FOREIGN PATENTS

25	753,531	Great Britain	July 25, 1956
----	---------	---------------	---------------