



Europäisches Patentamt
European Patent Office
Office européen des brevets



(11) **EP 0 906 867 A1**

(12) **EUROPEAN PATENT APPLICATION**

(43) Date of publication:
07.04.1999 Bulletin 1999/14

(51) Int Cl.⁶: **B65D 39/00, B65D 39/16,
B65D 101/00**

(21) Application number: **98203310.2**

(22) Date of filing: **30.09.1998**

(84) Designated Contracting States:
**AT BE CH CY DE DK ES FI FR GB GR IE IT LI LU
MC NL PT SE**
Designated Extension States:
AL LT LV MK RO SI

(72) Inventor: **Rekers, Pieter Jozef
8502 BD Joure (NL)**

(74) Representative:
**Smulders, Theodorus A.H.J., Ir. et al
Vereenigde Octrooibureaux
Nieuwe Parklaan 97
2587 BN The Hague (NL)**

(30) Priority: **01.10.1997 NL 1007193**

(71) Applicant: **Sara Lee/DE N.V.
3532 AA Utrecht (NL)**

(54) **Stopper bottle**

(57) The stopper bottle (1) comprises a bottle (2) with an opening and a stopper (4) detachably connected with the bottle. The stopper is arranged to be pulled from the bottle for opening the bottle and to be pressed into the opening of the bottle for closing the bottle again. The stopper is made up of a rigid upper cap (6) and a lower cap (10) connected with the upper cap, with a sidewall of the upper cap extending downwards into a space enclosed by the lower cap. A sidewall of the lower cap extends into the opening of the bottle. The lower cap further comprises a skirt (16) which extends around a neck of the bottle and which, at its upper end, is connected via a tear line with an upper end of the sidewall of the lower cap. Opening the bottle for the first time requires pulling the skirt from the sidewall of the lower cap along the tear line. By virtue of the skirt, the bottle cannot be opened without this being noticeable.

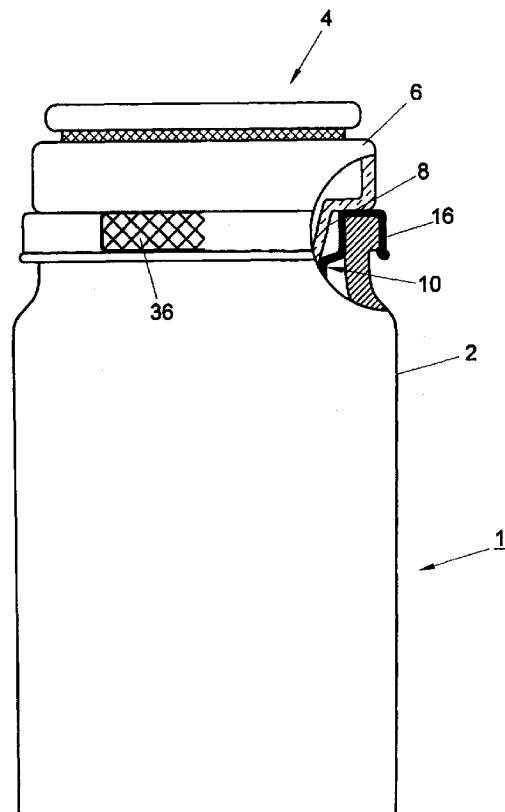

Fig. 1

EP 0 906 867 A1

Description

[0001] This invention relates to a stopper bottle comprising a bottle with an opening and a stopper, detachably connected with the bottle, which closes the opening, the stopper being arranged to be pulled from the bottle for opening the bottle and to be pressed into the opening of the bottle for closing the bottle again, the stopper being made up of a rigid upper cap and a lower cap, made of flexible material and connected with the upper cap, a sidewall of the upper cap extending downwards into a space enclosed by the lower cap, and a sidewall of the lower cap extending into the opening of the bottle. For years already, such stopper bottles have been used for packaging ground coffee or instant coffee.

[0002] A disadvantage of the known stopper bottle is that the stopper bottle, before being purchased by a consumer, that is, when, for instance, it is still on the shelf in a shop or in a storehouse of a supplier, can be opened by pulling the stopper from the bottle and subsequently be closed again by placing the stopper back onto the bottle again without this being evident from the bottle. Today's society, however, requires more and more that a stopper bottle, before being opened by a consumer, cannot be opened and subsequently closed again without this being evident from the bottle. To meet this problem, it has heretofore been proposed to provide a sleeve made of shrink foil around the neck of the bottle and the stopper. A disadvantage is, however, that such a sleeve can still be removed and re-placed without this being noticeable. It is also known to apply a seal which connects the stopper and the bottle with each other. It has been found, however, that the seal can be cut with a knife without the consumer subsequently noticing this.

[0003] The object of the invention is to provide a stopper bottle which obviates the above-mentioned disadvantages. Accordingly, the invention is characterized in that the lower cap further comprises a skirt which extends around a neck of the bottle and which, at its upper end, is connected via a tear line with an upper end of the sidewall of the lower cap, and opening the bottle for the first time requires pulling the skirt from the sidewall of the lower cap along the tear line. Such a construction allows the cap to be removed from the bottle only when the skirt is pulled from the rest of the cap via the tear line. When the skirt is absent, however, it will be immediately clear to a consumer that the bottle may have been opened. Thus, accordingly, a stopper bottle has been obtained, which precludes the possibility of its being opened by pulling the stopper from the bottle without this being noticeable.

[0004] Preferably, the skirt and the lower cap are made of the same material.

[0005] The invention also relates to a method for manufacturing a stopper bottle as described above. According to the method of the invention, the lower cap comprising the skirt is placed on the bottle, such that the sidewall of the lower cap extends into the opening of the

bottle, and the skirt extends around the neck of the bottle. Then the upper cap is pressed tightly onto the lower cap. In particular, the lower cap may then further be heated, so that the skirt shrinks and clings tightly around the neck of the bottle, before the upper cap is placed on the lower cap or after the upper cap is placed on the lower cap.

[0006] The invention will presently be further elucidated with reference to the drawings, wherein:

Fig. 1 is a partly transparent view of a stopper bottle according to the invention;

Fig. 2 is a cross section of the part of the stopper bottle according to Fig. 1 that is shown in transparent view in Fig. 1; and

Fig. 3 is a detail view of another part of the stopper bottle according to Fig. 1.

[0007] The stopper bottle 1 comprises a bottle 2 and a stopper 4 which closes off an opening, being circular in this example, of the bottle. The stopper 4 is arranged to be pulled from the bottle for opening the bottle and to be pressed into the bottle for closing the bottle again. The stopper 4 is made up of a rigid upper cap 6 which, at its lower end, comprises a circumferential sidewall 8 which tapers downwardly in this example. Further, the stopper comprises a lower cap 10 made of a flexible material, connected with the upper cap 6, having a sidewall 12 which is circumferential in this example. The sidewall 12 has likewise a conical shape, with the diameter of the lower cap decreasing in downward direction. The sidewall 8 of the upper cap extends downwardly into a space 14 enclosed by the lower cap 10. In particular, the sidewall 8 extends into a space enclosed by the sidewall 12 of the lower cap 10. In this example, the sidewall 12 of the lower cap extends into the opening 3 of the bottle 2.

[0008] The lower cap further comprises a skirt 16 which extends around a neck 18 of the bottle 2. At its upper end, the skirt 16 is connected via a tear line 20 with an upper end of the sidewall 12 of the lower cap 10. As can be properly seen in Fig. 2, in this example the profile of the skirt 16 corresponds with the profile of the neck 18 of the bottle 2. In this example, the skirt and the lower cap are made of the same material.

[0009] The sidewall 8 of the upper cap 6 comprises, adjacent the tear line 20, an outwardly offset shoulder 22. The sidewall 12 of the lower cap 10 here merges at its upper end into a bent portion 24 extending outwardly in radial direction along the underside of the shoulder 22, with an outermost portion 26 of the bent portion 24 connected to the skirt 16. The bent portion 24, in this example, extends at least substantially in horizontal direction. The tear line 20 extends roundabout along the neck of the bottle in the bent portion 24.

[0010] Adjacent its lower end 28, the skirt further comprises an edge 30 extending outwardly in radial direction. Further, the bottle 2 comprises, above this edge 30, a neck edge 32 bottle 2 comprises, above this edge 30,

a neck edge 32 extending outwards and to above the edge of the skirt. It further appears from Fig. 2 that the skirt, adjacent its lower end, further comprises a circumferential edge 34 extending outwardly in radial direction. As can be properly seen in Fig. 3, the skirt further comprises on its outer side a lip 36 for tearing loose the skirt 16 from the rest of the lower cap 10.

[0011] In the bottle according to Figs. 1-3, the stopper 4 cannot be removed from the bottle as long as the skirt 16 is present. In this example, the skirt 16 is even made of shrink foil, with the result that it is pulled tightly around the neck of the bottle. When someone tries to pull the stopper 4 from the bottle, he will not succeed in doing so, as the skirt 16 blocks this movement. Further, the edge 30 hooks under the neck edge 32, rendering it entirely impossible, even when applying great force, to pull the stopper 4 from the bottle. When a consumer, after he has purchased the bottle 1, wishes to remove the stopper 4 from the bottle 2, he does so by gripping the lip 36 and tearing the skirt 16 loose from the remainder of the lower cap 10 along the tear line 20. After the skirt has been removed, the bottle 2 can be opened by pulling the stopper 4 off the bottle. The stopper 4 can also be re-placed again, with the lower cap, owing to its flexibility, forming a proper seal again with the opening 3 of the bottle 2. Obviously, it will be immediately clear to a consumer that when the skirt is removed, the bottle may have been open. Accordingly, when upon purchase of a stopper bottle, the skirt is still present, a consumer can be certain that the bottle has not been open yet.

[0012] Manufacturing a stopper bottle as described hereinabove can be carried out very simply. The lower cap is placed on the bottle, together with the skirt already attached to it. This results in a situation according to Fig. 1, with the upper cap omitted. Placing the lower cap on the bottle can be easily carried out because the lower cap is made of a flexible material. Preferably, at least the skirt comprises a material which shrinks upon supply of heat. Accordingly, by supplying heat to the skirt of the lower cap, it can cling firmly around the neck of the bottle 2. Before or after the skirt is, optionally, heated, the upper cap can be pressed tightly onto the lower cap. The upper cap and lower cap are thereby connected to each other via a snap connection, known per se, which has been utilized in stopper bottles for a long time already. This snap connection has the property of subsequently disallowing the upper cap 6 to be pulled from the lower cap.

[0013] The invention is not limited to the embodiments outlined hereinbefore. Thus, it is possible for the opening of the bottle to have a shape different from the circular shape. The opening can be, for instance, of square or hexagonal design. The stopper 4 will then have a shape corresponding to that of the opening. Such variants are all understood to fall within the scope of the invention.

Claims

1. A stopper bottle comprising a bottle with an opening, and a stopper, detachably connected with the bottle, which closes the opening, the stopper being arranged to be pulled from the bottle for opening the bottle and to be pressed into the opening of the bottle for closing the bottle again, the stopper being made up of a rigid upper cap and a lower cap, made of flexible material and connected with the upper cap, a sidewall of the upper cap extending downwards into a space enclosed by the lower cap, and a sidewall of the lower cap extending into the opening of the bottle, characterized in that the lower cap further comprises a skirt which extends around a neck of the bottle and which, at its upper end, is connected via a tear line with an upper end of the sidewall of the lower cap, and opening the bottle for the first time requires pulling the skirt from the sidewall of the lower cap along the tear line.
2. A stopper bottle according to claim 1, characterized in that the profile of the skirt corresponds to the profile of the neck of the bottle.
3. A stopper bottle according to claim 1 or 2, characterized in that the skirt and the lower cap are made of the same material.
4. A stopper bottle according to any one of the preceding claims, characterized in that the opening of the bottle is circular.
5. A stopper bottle according to any one of the preceding claims, characterized in that the sidewall of the upper cap comprises, adjacent the tear line, an outwardly offset shoulder, the sidewall of the lower cap bending at its upper end to merge into a bent portion extending outwardly in radial direction along the underside of the shoulder of the upper cap, an outermost portion of the bent portion being connected with the skirt.
6. A stopper bottle according to claim 5, characterized in that the bent portion extends at least substantially in horizontal direction.
7. A stopper bottle according to claim 6, characterized in that the tear line extends around the neck of the bottle in the bent portion.
8. A stopper bottle according to any one of the preceding claims, characterized in that the skirt, adjacent its lower end, is provided with an edge extending inwardly in radial direction, and that the bottle, above the edge of the skirt, is provided with an edge extending outwardly and to above the edge of the skirt.

9. A stopper bottle according to claim 8, characterized in that the skirt, adjacent its lower end, further comprises a circumferential edge extending outwardly in radial direction. 5
10. A stopper bottle according to any one of the preceding claims, characterized in that the skirt, on the outer side thereof, is provided with a lip for tearing the skirt loose from the remainder of the lower cap. 10
11. A stopper bottle according to any one of the preceding claims, characterized in that the lower cap is made of a material shrunk by a heat treatment.
12. A method for manufacturing a stopper bottle according to any one of the preceding claims, characterized in that the method comprises the steps of placing the lower cap including the skirt on the bottle, such that the sidewall of the lower cap extends into the opening of the bottle and the skirt extends around the neck of the bottle; pressing the upper cap tightly onto the lower cap. 15 20
13. A method according to claim 12, characterized in that the lower cap is heated, so that the skirt shrinks and clings tightly around the neck of the bottle. 25

30

35

40

45

50

55

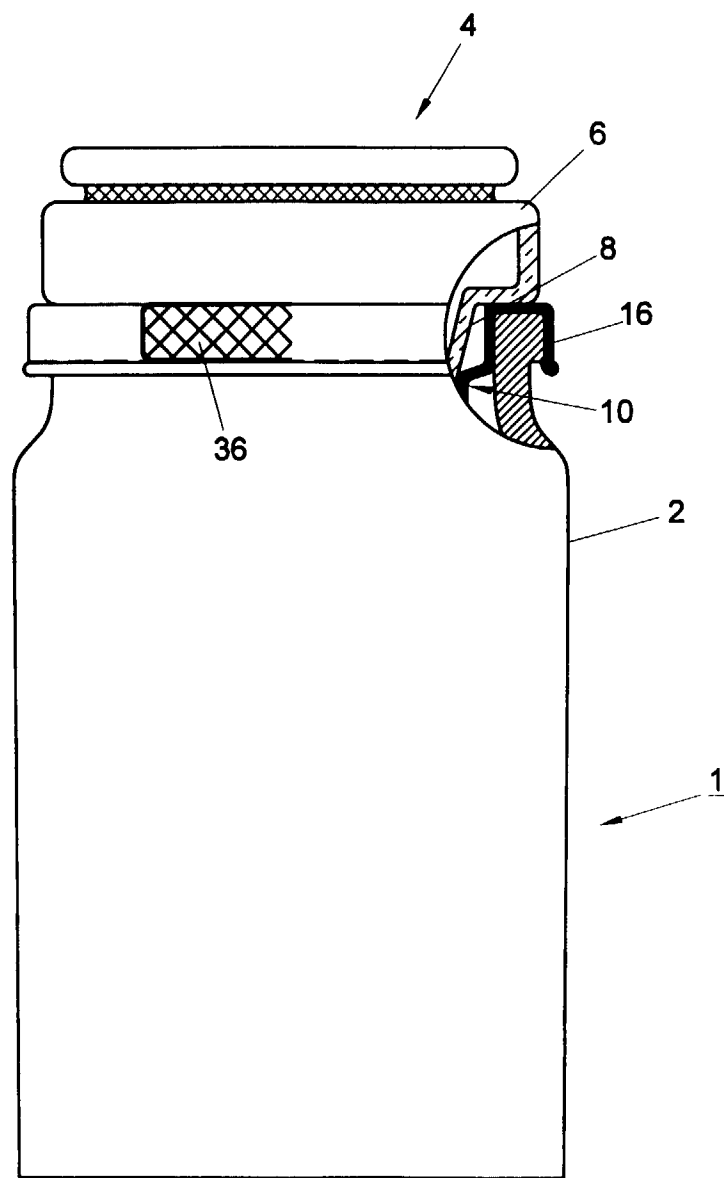

Fig. 1

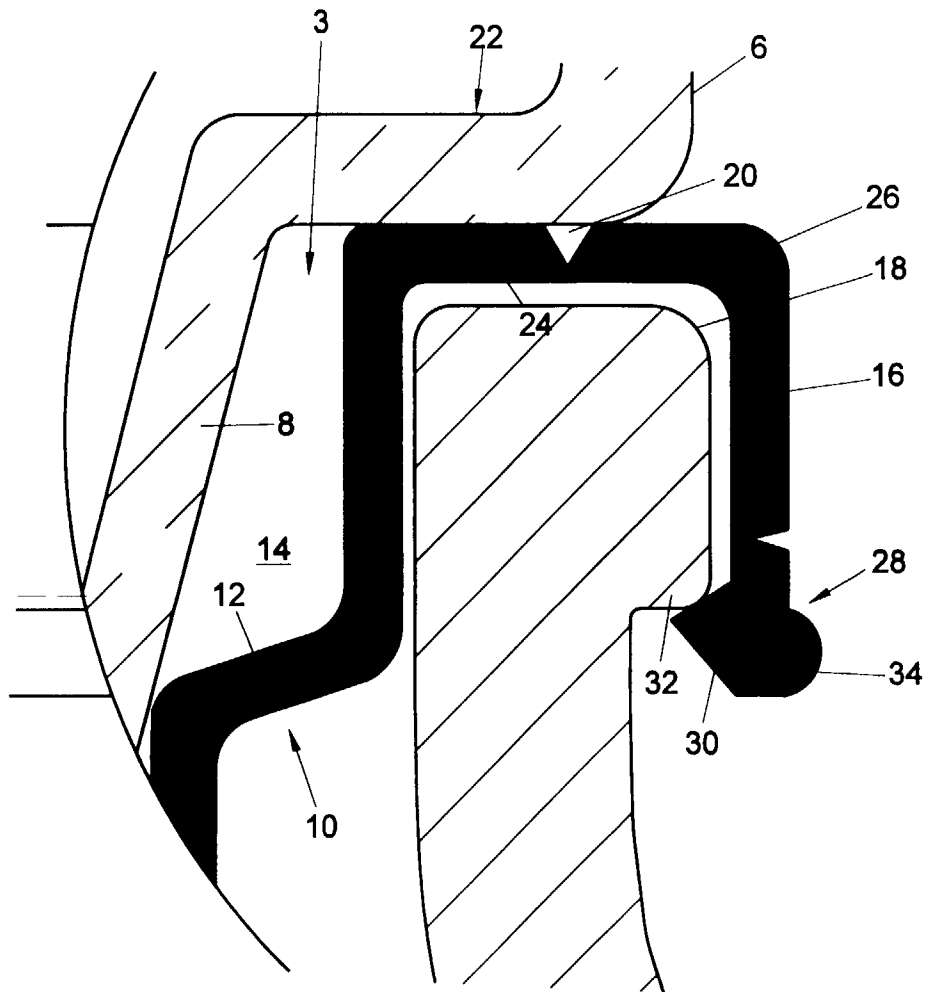

Fig. 2

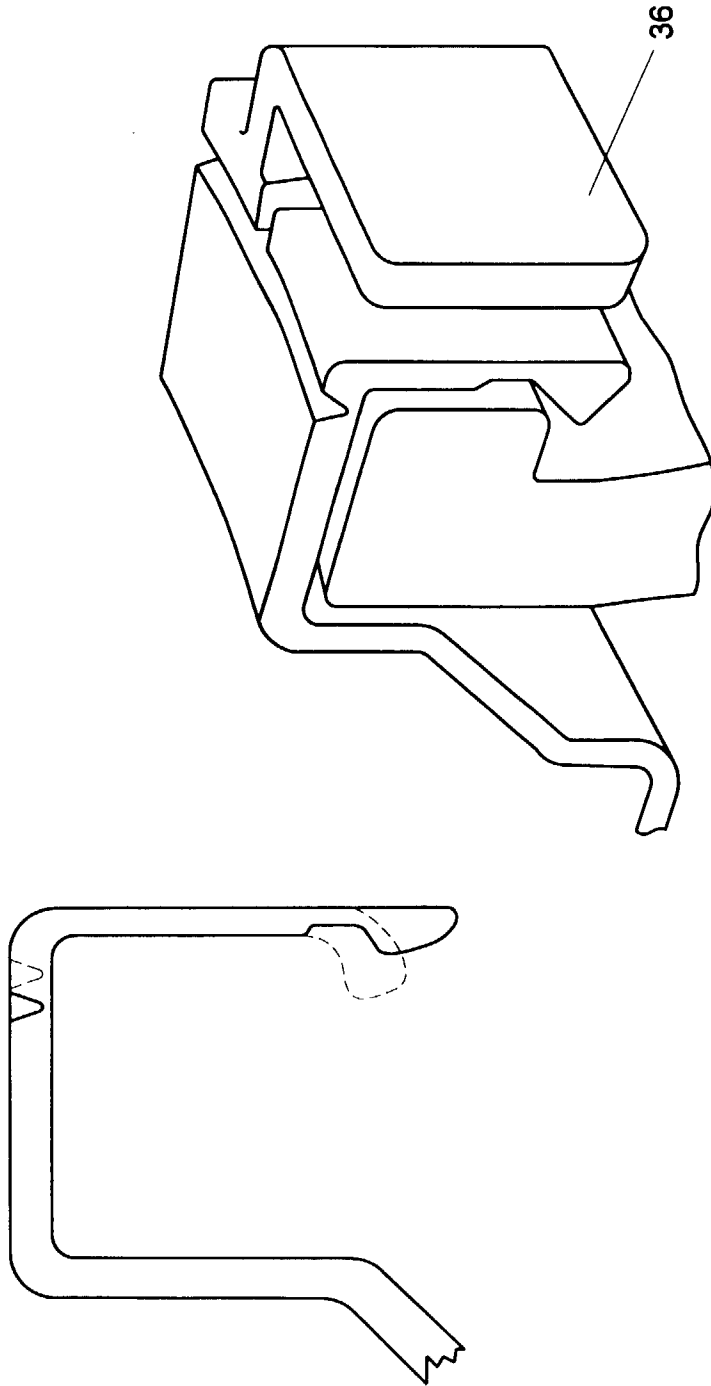

Fig. 3



European Patent
Office

EUROPEAN SEARCH REPORT

Application Number
EP 98 20 3310

DOCUMENTS CONSIDERED TO BE RELEVANT			
Category	Citation of document with indication, where appropriate, of relevant passages	Relevant to claim	CLASSIFICATION OF THE APPLICATION (Int.Cl.6)
A	DE 74 23 290 U (FR. HESSER MASCHINENFABRIK) 21 November 1974 * the whole document * -----	1-6,12	B65D39/00 B65D39/16 B65D101/00
			TECHNICAL FIELDS SEARCHED (Int.Cl.6)
			B65D
The present search report has been drawn up for all claims			
Place of search THE HAGUE		Date of completion of the search 6 January 1999	Examiner Martin, A
CATEGORY OF CITED DOCUMENTS		T : theory or principle underlying the invention E : earlier patent document, but published on, or after the filing date D : document cited in the application L : document cited for other reasons & : member of the same patent family, corresponding document	
X : particularly relevant if taken alone Y : particularly relevant if combined with another document of the same category A : technological background O : non-written disclosure P : intermediate document			

EPO FORM 1503 03.82 (P04C01)

**ANNEX TO THE EUROPEAN SEARCH REPORT
ON EUROPEAN PATENT APPLICATION NO.**

EP 98 20 3310

This annex lists the patent family members relating to the patent documents cited in the above-mentioned European search report. The members are as contained in the European Patent Office EDP file on
The European Patent Office is in no way liable for these particulars which are merely given for the purpose of information.

06-01-1999

Patent document cited in search report	Publication date	Patent family member(s)	Publication date
DE 7423290 U	21-11-1974	NONE	

EPO FORM P0459

For more details about this annex : see Official Journal of the European Patent Office, No. 12/82