

Oct. 13, 1925.

1,556,765

W. DECHMANN
HYDROPATHIC SPRAYING DEVICE

Filed Nov. 26, 1923

Fig. 1

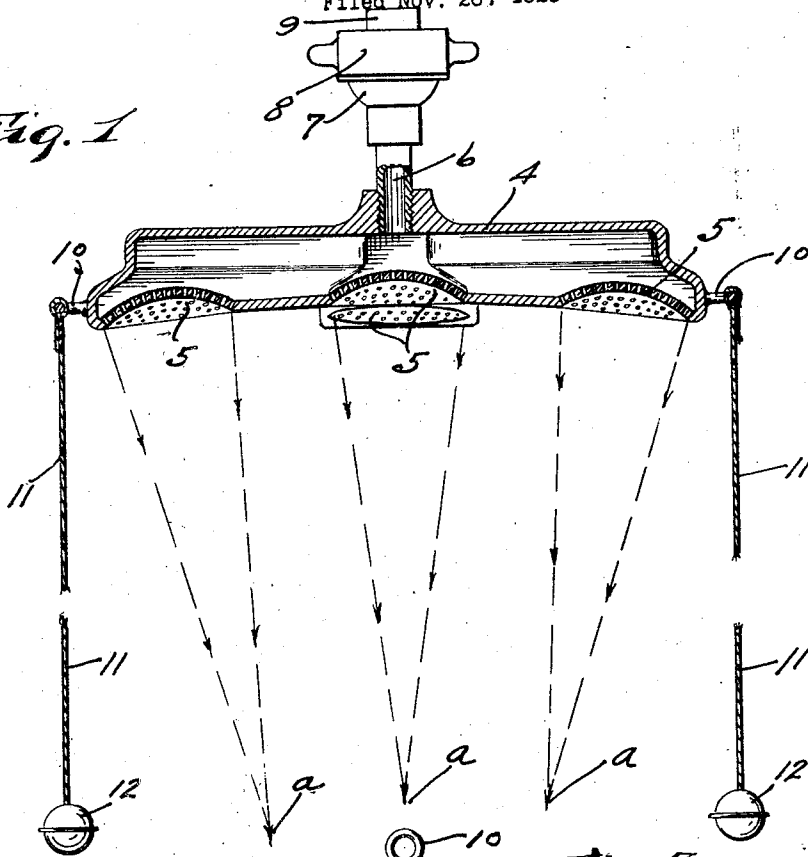

Fig. 2

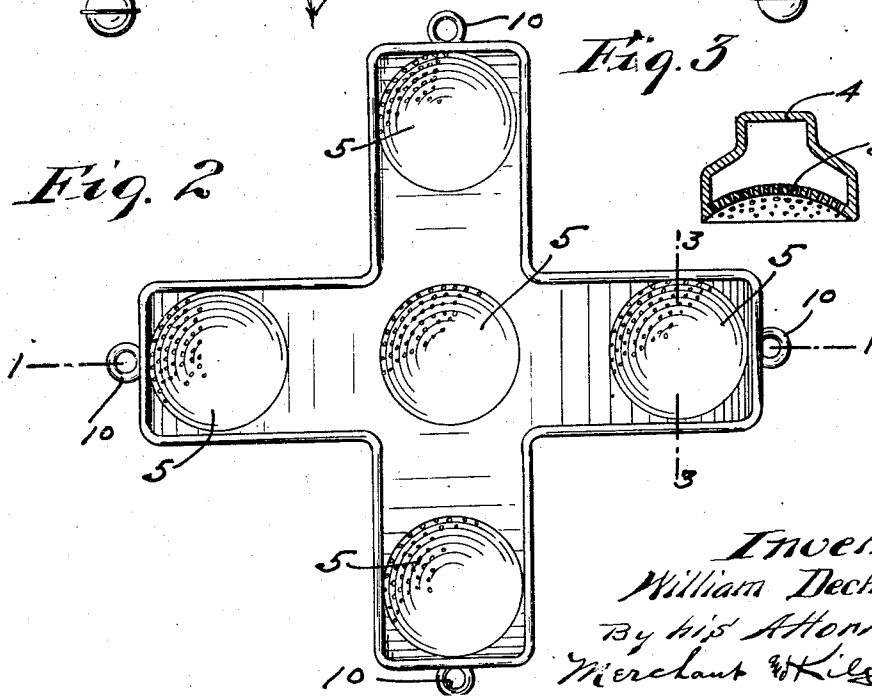
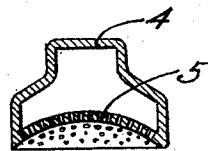

Fig. 3



Inventor
William Dechmann
By his Attorneys
Mercant & Kilgore

Patented Oct. 13, 1925.

UNITED STATES PATENT OFFICE.

WILLIAM DECHMANN, OF MINNEAPOLIS, MINNESOTA.

HYDROPATHIC SPRAYING DEVICE.

Application filed November 26, 1923. Serial No. 676,936.

To all whom it may concern:

Be it known that I, WILLIAM DECHMANN, a citizen of the United States, residing at Minneapolis, in the county of Hennepin and State of Minnesota, have invented certain new and useful Improvements in Hydropathic Spraying Devices; and I do hereby declare the following to be a full, clear, and exact description of the invention, such as will enable others skilled in the art to which it appertains to make and use the same.

My invention provides a simple and highly efficient water spraying device adapted for effective use in giving hydropathic treatments and which device is, therefore, herein designated as a hydropathic spraying device. A highly important feature of this invention is the arrangement whereby a multiplicity of groups of fine water streams discharged from the spraying device would be concentrated or focused and delivered on substantially a common point or line. This arrangement in the treatment of surface ailments by the use of a warm or hot water spray, affords means for producing a maximum surface irritation and blood circulation at the surface treated. The device is made readily adjustable so that the concentrated stream of warm or hot water may be shifted from one place to another over the body of a person lying, for example, on a slab under the spraying device in the bath or spraying room.

In the accompanying drawings, which illustrate the invention, like characters indicate like parts throughout the several views.

Referring to the drawings:

Fig. 1 shows the spraying device in transverse vertical section taken approximately on the line 1—1 of Fig. 2, some of the parts illustrated being in full elevation; Fig. 2 is a bottom plan view of the spraying device; and

Fig. 3 is a transverse section taken on the line 3—3 of Fig. 2.

The body of the spraying device is in the form of a hollow shell that may be cast or otherwise made but is provided with a plurality of radial arms or portions and is preferably made with four arms in rectangular arrangement forming a cross. This shell 4 is shown as a cast shell, preferably of brass, and on its under side is

formed with five concave spherical finely perforated nozzle-forming zones 5, one zone being located at the center of the shell and one zone being located close to the extremity of each arm. By reference to Fig. 1, it will be noted that the under surface of the shell, from the end of the one arm to the end of the diametrically opposite arm, is made concave so that the axes of the several perforated zones 5 converge downwardly towards a common point. Also, it will be noted that the perforations in each zone 5 converge downwardly toward a common point on the projected axis of the zone. With this arrangement, as will be observed by reference particularly to the dotted lines and arrows on Fig. 1, the multiplicity of fine streams of water projecting downward through the perforations of a particular nozzle-forming zone 5 will first be concentrated approximately as indicated at *a* and the fine streams of each zone will be there joined in a single stream and the several streams of water condensed at *a* will, at a point lower down, to wit: approximately at the point where they will be arranged to strike the body of the person being treated, be concentrated into a single stream.

The spraying head or shell above described should be yieldingly supported so that it may be adjusted for the delivery of the concentrated stream of warm or hot water wherever desired on the body of the person being treated. As an efficient means for accomplishing this result, I have shown a short pipe section 6 tapped into the top of the central portion of the shell 4 and at its upper end having a coupling member 7 secured to a coupling member 8 on a fixed warm or hot water supply pipe 9. These coupling members will preferably be of a type to permit the shell or spraying head to be oscillated universally in all directions and will frictionally hold the said shell in any position in which it may be set.

As a convenient means for adjusting the shell to different points of delivery, its arms are shown as provided at their ends with eyes or perforated lugs 10 to which adjusting cords 11 are attached. As shown, the cords 11 are provided at their lower ends with balls 12 that serve as combined weights and hand pieces, making it an easy matter to accomplish the adjustments of the sprayer above indicated.

This spraying device differs from the ordinary form of spraying device or nozzle used, for example, in shower bath devices, in that the latter are universally made to throw a diverging spray, while the present device is primarily designed to throw or precipitate a concentrated spray which will produce a maximum irritation and resultant circulation of the blood at the point of delivery on the body of the person being treated. Otherwise stated, this device is primarily designed for use as a hydropathic or therapeutic device, and the bath feature is either of no special importance or a decidedly minor and incidental feature. Of course, by placing the body varying distances from the nozzles, a varying extent of surface may be covered by the sprays, with resulting varying intensity at any particular spot. Of course, if the body is placed above the focus of the several nozzles, a number of sprays will be delivered and these at several different points.

This device, in actual practice, has been found highly efficient in giving hydropathic treatments of the character indicated.

What I claim is:

1. A hydropathic spraying device comprising a hollow shell connected to a source

of water supply and having a plurality of perforated nozzle-forming spraying zones each arranged to precipitate a plurality of fine streams of water on downwardly converging lines concentrating in approximately a single stream.

2. A hydropathic spraying device comprising a hollow shell connected to a source of water supply and provided with a central and a plurality of surrounding circumferentially spaced concave nozzle-forming spraying zones, the perforations of which downwardly converge toward points on the projected axes of said concave zones.

3. A hydropathic spraying device comprising a hollow shell connected to a source of water supply and provided with a central and a plurality of surrounding circumferentially spaced concave nozzle-forming spraying zones, the perforations of which downwardly converge toward points on the projected axes of said concave zones, and the several concave zones being set with their axes converging downwardly toward a common point below the central nozzle-forming zone.

In testimony whereof I affix my signature.

WILLIAM DECHMANN.