

T. Flint.
Shuttle Box.

Sheet 1-3 Sheets.

N^o 2,696

Patented Jul. 2, 1842.

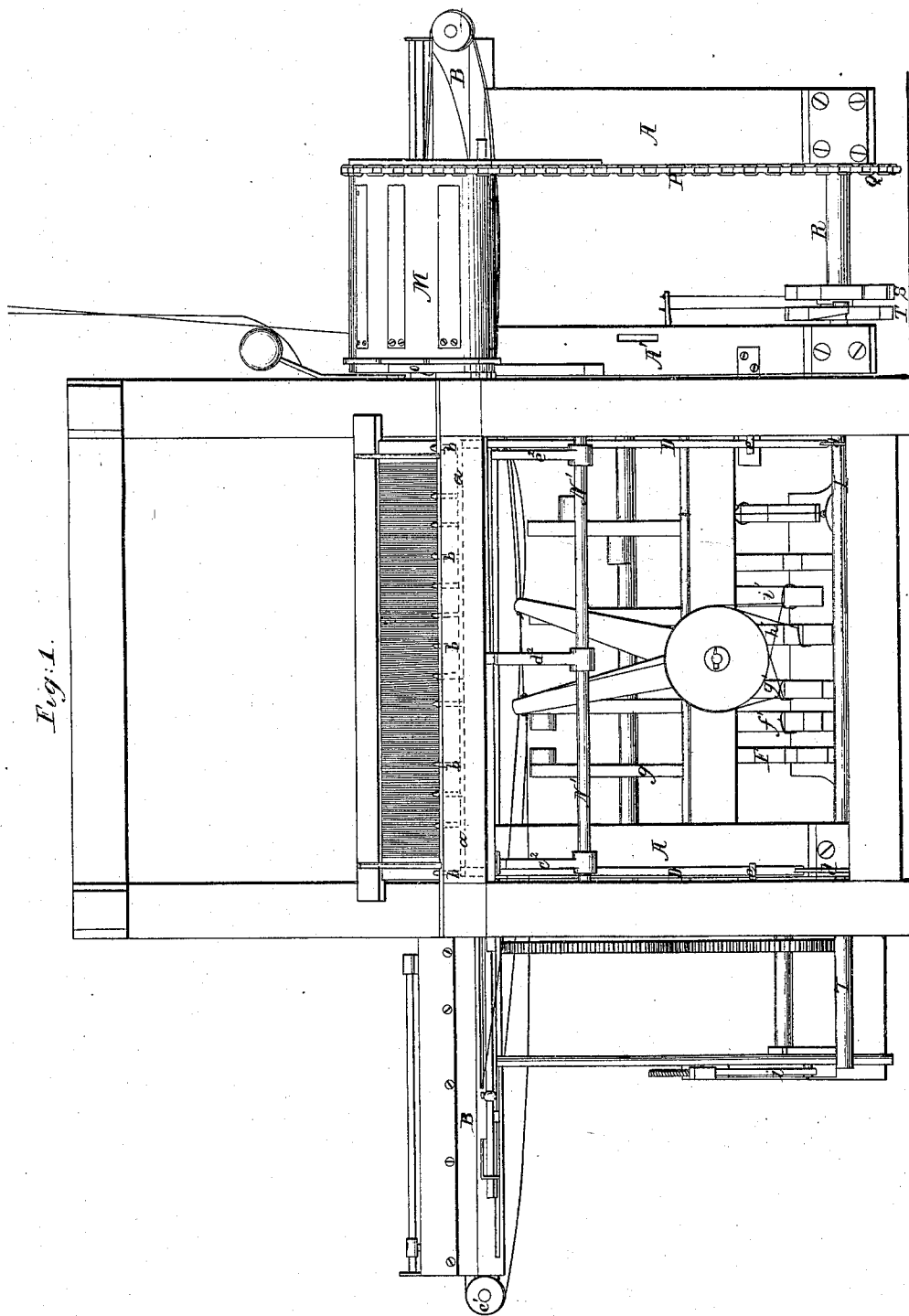

Fig. 1.

T. Flint.
Shuttle Box.

Steel 2-3 Sheets.

N^o. 2,696.

Patented Jul. 2, 1842.

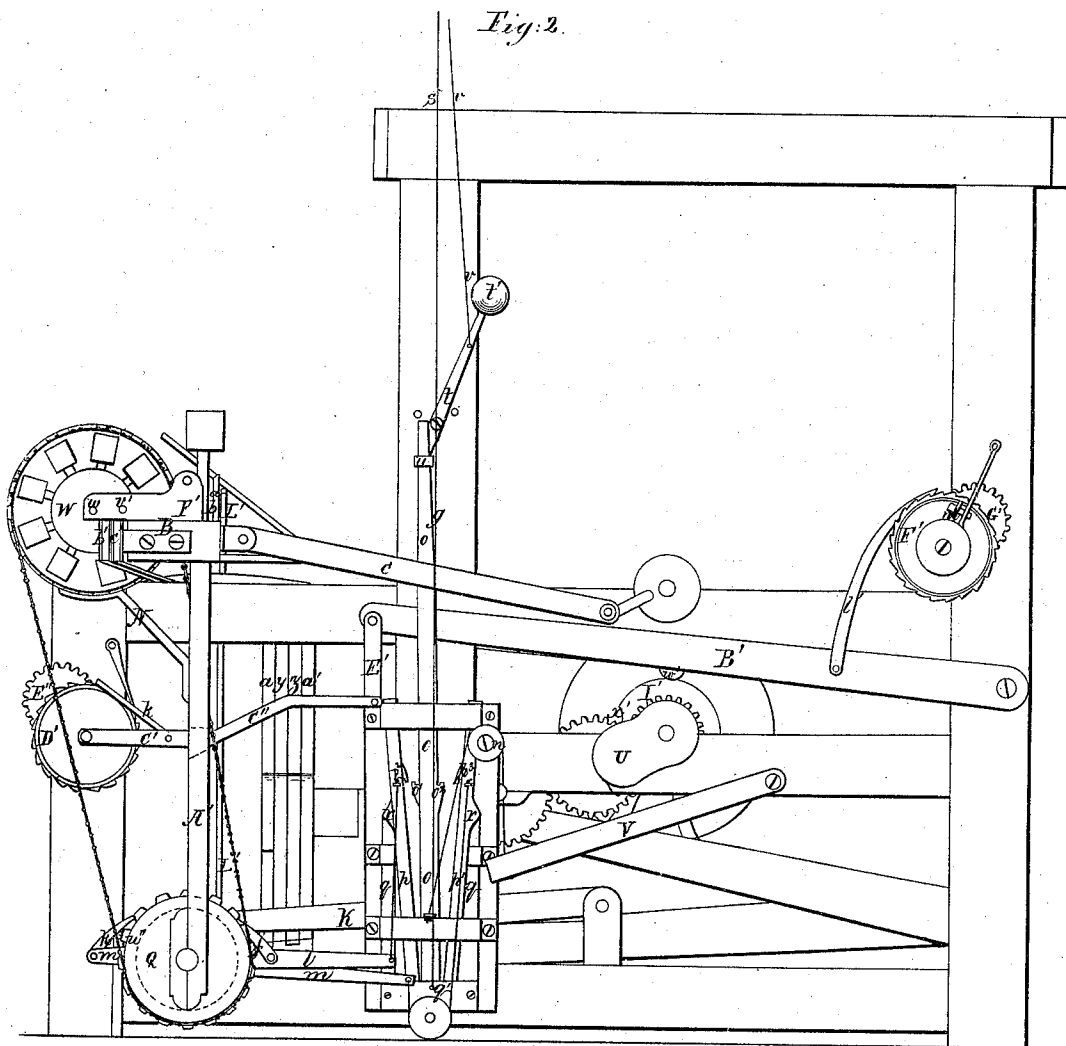

T. Flint.
Shuttle Box.

Sheet 3-3 Sheets.

N^o. 2,696.

Patented Jul. 2, 1842.

Fig. 4.

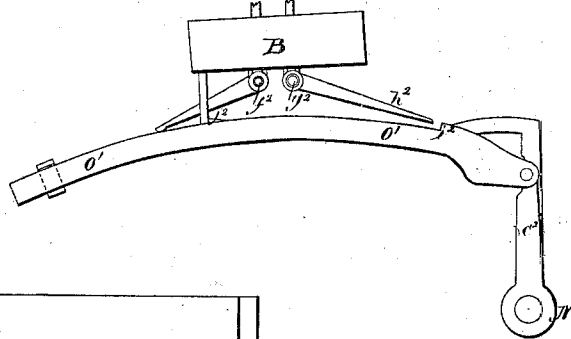
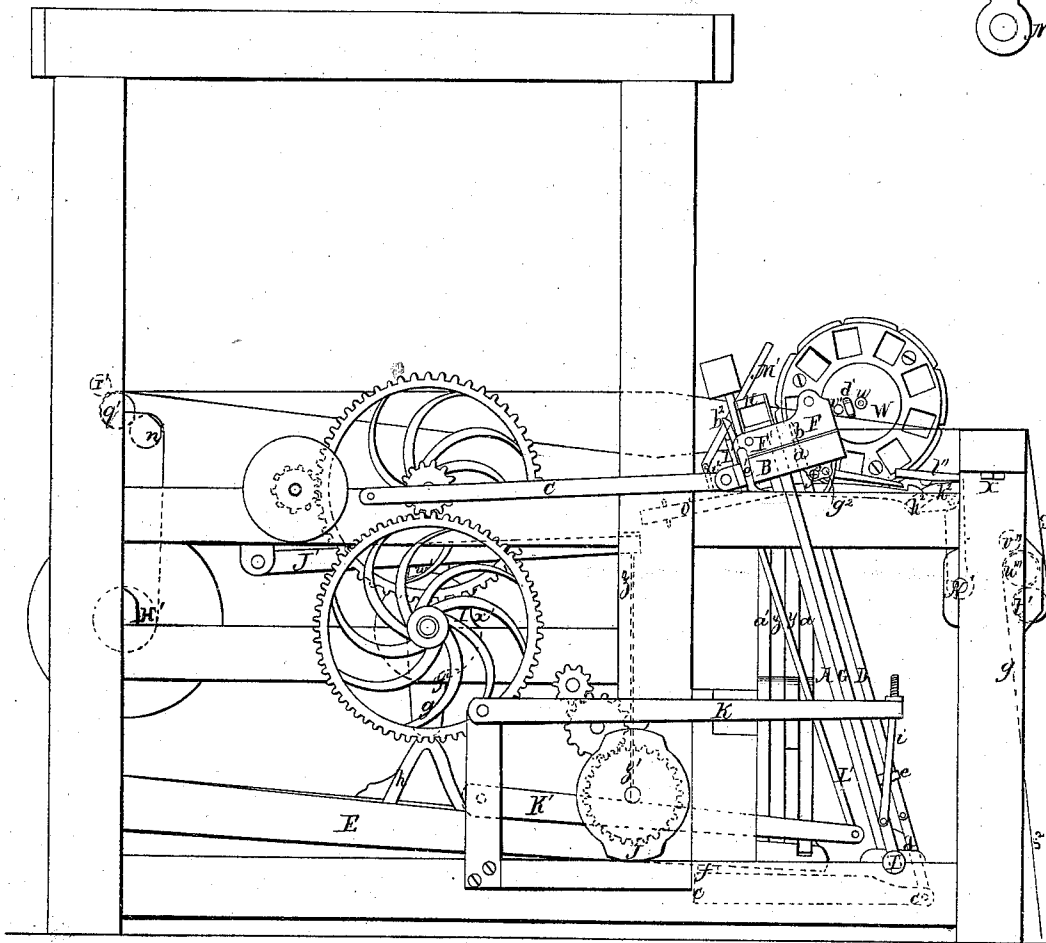

Fig. 3.



UNITED STATES PATENT OFFICE.

THOMAS FLINT, OF BOSTON, MASSACHUSETTS.

POWER-LOOM FOR WEAVING CARPETS AND OTHER FIGURED, STRIPED, OR CHECKED FABRICS.

Specification of Letters Patent No. 2,696, dated June 27, 1842.

To all whom it may concern:

Be it known that I, THOMAS FLINT, of the city of Boston, in the State of Massachusetts, have invented certain improvements in power-looms for weaving carpets of the kind denominated ingrain, three-ply, and others, and which improvements may be in whole or in part applied to the weaving of other figured fabrics and to goods woven in stripes or checks of various kinds; and I do hereby declare that the following is a full and exact description thereof.

The frame of the loom may be of wood, or of iron. In the accompanying drawing it is represented as made of wood, but it will generally be made of iron. For the forming of the figure, the jacquard machine is to be employed, but as this is to be constructed and applied in the ordinary way, it does not require to be described or represented in the drawings.

My first improvement consists in the so constructing of the lathe as that there shall be on its upper side, or race beam, two or more separate shuttle races; for which purpose the race beam is made of greater width than usual; the provision made for dividing or separating these shuttle races from each other will be presently explained.

In the accompanying drawings, Figure 1 is a front elevation of the loom. Fig. 2 is an end view thereof on the right hand, and Fig. 3, a similar view of the left hand end.

A, A, are the swords of the lathe, which are represented as working upon joints at their lower ends, in the usual manner, and this I consider the most convenient manner of affixing them. In Fig. 1, the principal part of the race beam is hidden by the breast beam, but B, B, are portions of it, and B, B, Figs. 2 and 3, are the outer ends thereof showing it as made of much greater width than usual. C, C, are the connecting rods by which the lathe is vibrated by a crank motion, in the ordinary way, but its vibration is to a greater distance than is necessary where there is only one shuttle race.

To divide the race beam so as to form two shuttle races upon it, I employ what I denominate a comb, which consists of a bar of metal, which runs along and is let into a groove on the under side of the race beam. From this bar there rises a number of wire teeth, or needles, which may be two or three inches apart and which pass up through

holes adapted to them in the race beam. These teeth project above the race beam during the passing of the shuttles along the front race, but are withdrawn when the lathe is moved to beat up the thread. From the ends of the bar constituting the back of the comb, rods descend to a treadle frame which is worked by a cam, for the purpose of projecting and withdrawing the comb teeth. In Fig. 3, D, is one of these rods; *a*, is one end of the comb bar, shown in dotted lines, and *b*, one of the teeth projecting above the race beam; the place of these is shown, also, by dotted lines in Fig. 1. The rod D, is connected at bottom to a vibrating frame *c, c*, shown in dotted lines, this being effected by means of a connecting piece *d*, having joint pins at each end; this arrangement allows the rod D, to slide up and down through a guide piece, *e*, affixed to the lathe sword; the rods D, D, are thus enabled to vibrate with the lathe. E, is a treadle, the outer end of which is made to bear upon the frame *c, c*, as at *f*, so as to vibrate it, and to cause the comb teeth to rise; *h*, is a shoe, or projection, on the treadle E, which is acted upon by arms, or cams, *g*, which have friction rollers on their ends. When the frame *c, c*, is not acted upon by the cam, the comb teeth may be retracted by a weight, or spring, acting on the frame, or by its own gravity. A rod similar to D, with its appendages, as above described, is used on the opposite side of the lathe. The race beam may be made wide enough to form more than two shuttle races upon it, on the same principle, but I am of opinion that by means of two races, with the other improvements herein described, every desirable result may be attained without rendering the machine too complex.

Upon that end of the race beam which is shown on the left hand in the drawing there are two shuttle boxes, the outer ends of which are formed by the plate F, F'. That terminating at F, is in front of the comb teeth *b*, and that at F', is in the rear of F. The shuttle box F, is to receive the shuttles from a rotary shuttle box, to be presently described; and that at F', from a shuttle box in the rear of the rotary shuttle box situated at the opposite end of the loom, in the position indicated by F', Fig. 2. On the back race there may be two or more shuttle boxes standing one over the other,

so as to contain and operate two or more shuttles, according to the nature of the work to be performed; these vertical, or drop, shuttle boxes are to be raised and lowered by means of suitable machinery so as to make the required changes; this motion may be effected in different ways, but that which I have preferred is as follows: In Fig. 3, G, is a rod carrying a double shuttle box, the uppermost of which boxes is shown as elevated, at H. The rod G, slides, at its lower end through a hole in the shaft I, of the lathe, and is raised and lowered by means of the revolving cam J, which operates on the lever K, said lever being connected to the rod G, by the jointed bar \dot{z} . The cam J, may be so formed and geared as to operate upon more than two boxes, if required.

My next improvement consists in the manner in which I construct, arrange, and operate a revolving cylindrical shuttle box. In the accompanying drawing M, represents this shuttle box, which is shown as containing nine shuttles, but any other number, greater or smaller than this may be formed in it, the limit being that of convenience alone. The shuttle cylinder M, is supported upon two iron brackets N, N, attached to the swords of the lathe; this cylinder is embraced for more than half its circumference by two segments of hoops O, O, which springing in upon its two ends, make friction upon it, and thus hold it steadily when at rest, and still allow it to revolve so as to carry a new shuttle into the proper situation to be thrown by the picker along the front race, a portion of the race beam being cut away to receive it. The shuttle cylinder is made to revolve by means of a gearing chain P, which chain passes on to teeth, or cogs, on one end of the shuttle cylinder, and on to those of a cogged, or chain, wheel Q, on the shaft R, which shaft is tubular, and passes over the shaft I, I, of the lathe. On this tubular shaft there are two ratchet wheels S, and T, operated upon by pawls in such manner as to reverse the direction of the cylinder after it has performed a revolution, or a partial revolution. In the end view Fig. 2, the ratchet wheels S, and T, are hidden by the chain wheel Q, but the pawls and the levers to which they are attached are distinctly seen, and their construction and operation are the same with that of other ratchet wheels. The pawl j , acts on the ratchet wheel S, and the pawl k , on the ratchet wheel T; the levers l , and m , which carry the pawls j , and k , embrace the shaft R, which thus becomes their fulcrum.

I will now describe the manner in which the levers l , and m , are brought into action, and the motion of the shuttle cylinder reversed.

U, is a cam on the end of the cam shaft,

which in its revolution comes into contact with the lever V; from the outer end of the lever V, a line passes over a pulley n , and is attached to a rod o, o , which is free to rise and fall vertically against the end of the frame of the loom, and it is thus made to rise and fall at every revolution of the cam U; but as it is shown in the drawing it would do so without communicating motion to any part of the machinery. p, p' , are two rods which, like o , are capable of sliding up and down against the end of the loom; o', o'' , are projecting or latch pieces on the sides of o, o , and p^2, p^3 , are similar latch pieces on the inner edges of p, p' ; the rods p, p' , are capable of being brought nearer together at their upper ends than as shown in the drawing, and this is effected by a sliding frame q, q , the upper ends of which, when said frame is raised, acting by their inclined terminations on the inclined pieces r, r , attached to p, p' , force their upper ends inward, so that one of the latch pieces p^2, p^3 , may be acted upon by the latch pieces on o, o ; by giving an inclination to the rod o, o , to the right or to the left, it may be made to engage with either of them as may be desired. s, s , is a line descending from the jacquard machine and attached at its lower end to the frame q, q , at q' , for the purpose of lifting said frame by the action of the jacquard machine, at the time when the pattern requires it; a thing well understood by those conversant with the use of that instrument. To determine which of the rods, p , or p' , shall be lifted, the rod o, o , is capable of being inclined toward one or the other of them; as represented in the drawing, it is inclined toward p , and if the frame q, q , was raised, and the rod o, o , was forced up and down, the rod p , would rise and fall with it. The inclination of the rod o, o , is determined by the lever t , which admits the rod o, o , to pass through a hole in a piece u , attached to its lower end; and by reversing the inclination of this lever, that of the rod o, o , would be reversed; a line v, v , leading to this lever from the jacquard machine is acted upon by a sudden pull when this reversing is to be effected, the weight t' , acting by its momentum effects this object. When the rod p , is lifted it will raise the lever l , and turn the ratchet wheel S; and when p' , is lifted it will, in like manner, act upon the ratchet wheel T, and reverse the motion; the arrangement of the lines and pulleys for this purpose being distinctly represented in the drawing. The number of teeth in the ratchet wheels S, and T, correspond with the number of shuttles in the shuttle cylinder, so that each action of one of the pawls will carry said cylinder to the proper distance. When the shuttle cylinder has been carried entirely around, it is necessary that the motion should be reversed; but it may be car-

ried any required portion of a revolution, and then reversed, by a corresponding disposition of the motions derived from the jacquard machine. When the pawls *j*, and *k*, are not in action, their ends are raised so as not to engage with the ratchet wheels. This may be effected by allowing the levers *l*, and *m*, to drop a little below the point at which their pawls would fall into the notches on the wheels; and thereby to bring the pawls into contact with a stationary pin, as shown at *u'*, under the pawl *k*; when the lever is slightly raised the point of the pawl will drop, and engage with the ratchet teeth.

W, W, Figs. 2, and 3, are loose heads which sustain the picker rod *v'*, and a center rod *w*; and around these the shuttle cylinder revolves. There are four picker staves *x*, *y*, *z*, and *a'*, represented in the drawing, which are operated by four treadles in the usual way. From the ends of two of these a picker cord passes around the pulleys *b'*, and *c'*, Fig. 2, by which it is conducted through the shuttle cylinder, and at the other end of this it passes around a pulley *d'* Fig. 3, in the loose head W, of said cylinder. The cord by which the picker is operated for throwing the shuttle from the rear shuttle box at *F'*, on the end of the loom opposite to that at which the shuttle cylinder is situated, passes around a pulley *e'*, its ends being, of course, attached to the picker staves. The picker strap, or cord, which passes around the pulleys *b'*, and *c'*, on the end of the race beam, has its two ends attached to two separate picker staves; by the action of one of which the shuttle is thrown, while by the action of the other the picker is drawn back, the motion of the strap, or cord, being reversed by its passing around the pulley *d'*. The nature and object of this arrangement, for throwing the shuttles on the two races, and from the revolving shuttle cylinder, and of drawing back the picker within the cylinder, will be obvious without further description, to those who are familiar with the construction of power looms. The four treadles for operating the four picker staves are shown at *f'*, *g'*, *h'*, and *i'*, in Fig. 1; and these are acted on by cams on the cam shaft, in the usual way. There may be more than four picker staves, if required by the nature of the work to be performed; that is, when the loom is so constructed as to increase the number of shuttle boxes; but the number here given is sufficient for exemplifying the principle of action.

I have also invented a new and improved manner of arranging and combining the apparatus for effecting the let-off motion from the yarn beam, and the take-up motion of the cloth beam, which I effect, principally, by an arrangement of levers which are operated upon by the motion of the lathe; and

actuate the rollers and give out the warp, and take up the cloth, simultaneously, by their action upon cams and pawls of the ordinary construction. The arrangement of the principal parts concerned in this process is shown in Fig. 2. In this figure, *B'*, is a lever having its fulcrum at *j'*; and *C'*, is an iron lever having its fulcrum on the axis of the ratchet wheel *D'*. The levers *B'*, and *C'*, are connected by a link, or bar, *E'*, having joint pins at each end, so that the inner ends of the two levers will rise and fall together. The lever *C'*, passes through a mortise in the sword *A'*, of the lathe, shown by the dotted lines and seen at *A'*, in Fig. 1. As the lathe moves in, the lever *C'*, is depressed, by the upper part of the mortise through the lathe sword coming into contact with the inclined part *C''*, of the lever, which likewise depresses the lever *B'*; the lever *C'*, draws down the hooked pawl *k'*, which turns the ratchet wheel *D'*; a pinion on the back of this wheel gears into the wheel *E''*, on the gudgeon of one of the take-up rollers, and causes it to take up a portion of the finished cloth. The hooked pawl *l'*, at the same time, by a similar action, draws around the ratchet wheel *F'*, which, by a pinion on the back side thereof, turns the toothed wheel *G'*, on the gudgeon of one of the rollers around which the yarn passes from the yarn beam, and thus causes it to let off a given quantity of warp. A friction clip *m'*, is used to prevent the moving of the wheel *F'*, excepting when acted upon by the pawl *l'*. The let-off and take-up motions may be so graduated as to cause the portion of yarn given out to exceed the portion of cloth taken up, in any degree that may be found necessary. In Fig. 3, I have shown the course of the yarn and cloth, in red, and dotted lines. *H'*, is the yarn beam, from which the yarn passes up in front of a roller at *n'*, between it and a roller at *q'*, over this roller, and between it and an iron pressing, or weight, roller *r'*; the rollers *n'*, and *q'*, are geared together, and pressing the yarn between them, give out a quantity of warp, which is governed by their revolution. The take-up rollers are similarly arranged. The cloth *S'*, after passing over the breast beam, descends in front of and around, a roller at *t'*, then between it and a roller at *u''*, and then between this and an iron weighting, or pressing, roller at *v''*, from which it descends as seen at *S²*, *S²*. The rollers *t'*, and *u''*, are geared together, embrace the cloth between them, and by their motion take it up regularly. In Fig. 1, the cloth rollers, and the weight, or pressing, roller are not represented, being omitted for the purpose of showing the parts immediately in the rear of them.

The manner of stopping the loom, if the shuttle does not return home, which I have

adopted differs from that employed in other looms. In Fig. 1, N' , N' , is a shaft extending along below the inner edge of the breast beam; one of its gudgeons being seen at N' ,
 5 Fig. 3. From this shaft rise three arms c^2 , d^2 , and e^2 . To the upper ends of c^2 , and e^2 , are attached curved slides, as shown detached at O' , O' , Fig. 4. These slides pass
 10 curvature being such as to correspond with its motion. One of these slides is shown by dotted lines at O' , Fig. 3. Under the lathe there extend along two rods f^2 , and g^2 , Figs. 3 and 4, to which rods fingers are attached,
 15 as in the common stop motion, and from these proceed two catches, or pawls, h^2 , which when the shuttle does not return home, fall and catch into a notch i^2 , on the slides O' , and force them forward, and in so doing act
 20 upon a vibrating lever placed under, and attached to, the breast beam, which lever operates upon the shipper in the usual manner.

The shipper is not represented in the drawing, as it does not differ from that in
 25 common use, but the end of the vibrating lever, under the breast beam, which acts upon said shipper is seen at X , Fig. 3. This lever is acted upon in the following manner. From the upper end of the arm d^2 , a curved
 30 piece extends inward toward the lathe, as represented in part by dotted lines at k^2 , Fig. 3, and when this is forced back, it raises a protector l^2 , which works on a joint pin on the inner end of the lever X , under the
 35 breast beam; and when so raised it is struck by a stud, or dead iron, on the under side of the lathe, and the loom is thereby stopped, the lever X being vibrated, and the shipper made to operate.

The arrangement by which the loom is stopped in case of the breaking of a thread, or the running out of a bobbin differs in part from those heretofore adopted for that purpose. I' , is a cam near the end of the main
 45 cam shaft, which cam operates on a lever J' , having a projecting piece w' , on its lower side; the cam I' , is circular, but has two hollows x' , and y' , into which the projecting piece w' , will pass and allow the lever to descend; the lever J' , is connected by a rod
 50 z' , z' , shown by dotted lines, to a lever K' ; this latter lever has a rod L' , L' , at its outer end, which extends up, and passes through a staple, or eye, on the back side of the race
 55 beam, and bears against the under side of a lever M' , the fulcrum of which is at a^2 ; the lever M' , will consequently be raised and lowered by the action of the rod L' . b^2 , is a finger, or short rod, which has a loop, or
 60 eye, at its upper end, embracing the lever M' , and by which it is carried up and down with that lever, which is raised as in the position shown in the drawing, when the shuttle is thrown, and drops when the shuttle has passed. If the thread is whole the

lever is sustained upon it, but if the thread is broken, or has run out, the lever descends so as to pass into a groove, or notch, cut across the race beam to receive it, and in so
 70 doing it carries the finger a^2 , down with it, which then takes into the notch j^2 , in the slides o' , o' , under the lathe, and operates upon said slides as in the case of the shuttle not returning home, and stops the loom. The above described apparatus is repeated
 75 at the opposite end of the loom, and a part of it is shown in Fig. 2, where it is designated by the same letters as in Fig. 3.

Having thus, fully described the nature of my improvements on the loom for weaving
 80 carpets, and other figured fabrics, including stripes and checks of various kinds; and having also shown the manner in which the respective parts thereof operate, what I claim therein as new, and desire to secure by
 85 Letters Patent, is as follows.

1. I claim the forming and using of two, or more, race ways on one race beam, in combination with two, or more, shuttle boxes at each end of said beam, one in the rear of the
 90 other; and this I claim whether one, or more, of those boxes be made to receive two, or more, shuttles, and to rise and fall vertically for that purpose, and whether the cylindrical shuttle box, herein described be employed or not; the division between said races being
 95 formed by means of a comb, the teeth, needles, or points, of which, are alternately raised and retracted, substantially in the manner, and for the purpose, set forth. I am aware that a comb furnished with teeth,
 100 or needles, and operated in a manner somewhat resembling that above described, has been used in looms for weaving of what is denominated lappet goods; the needles, or
 105 teeth, being employed in this case to protect the goods from the action of the shuttle in their passage along the race, but not forming thereby a double race, as in my loom; I do not, therefore, claim the use of
 110 said comb, or needles, excepting in combination with my double race, furnished with shuttle boxes one behind another as set forth.

2. I claim the manner of rotating and vibrating the cylindrical shuttle box, by means
 115 of the chain wheel, levers, ratchet wheels, sliding frame and sliding rods, connected with the jacquard machine and with each other, so as to cooperate in producing the desired effect as set forth. I am aware that
 120 shuttle boxes have been formed one above the other and have been sustained by arms or otherwise, so as when shifted to perform their motions in the segment of a circle; but this has been effected by an arrangement of
 125 the respective parts, differing essentially and substantially from that invented by me, and herein fully made known. It is to be understood therefore that my claim to this part of my apparatus is not the merely mov- 130

ing of shuttle boxes in a segment of a circle, but is to the use of a cylindrical shuttle box combined, arranged, and operating, substantially as herein described. I will further remark that although the revolving and other shuttle boxes, described by me are spoken of and represented as attached to, and vibrated with the race beam of the lathe, they may be attached to parts of the structure which do not vibrate, but remain stationary; in which case the shuttles may still be acted

upon in a similar manner and the general construction and arrangement of the boxes may also be substantially the same as that herein described such particular devices being used as will then become requisite to connect the motions of the shuttle with that of the lathe.

THOMAS FLINT.

Witnesses:

BENJ. JUDKINS, Jr.,
H. B. TIBBETTS.