

May 15, 1956

G. PODMORSKI

2,745,111

PERSONAL RELIEF DEVICE

Filed May 13, 1953

2 Sheets-Sheet 1

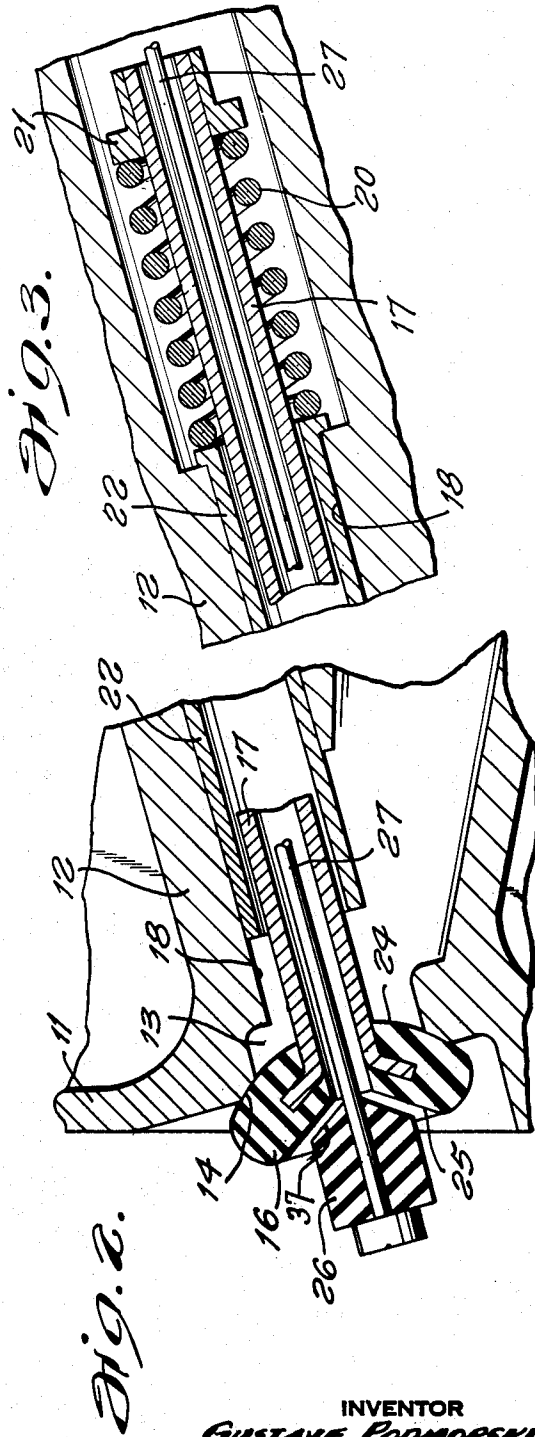
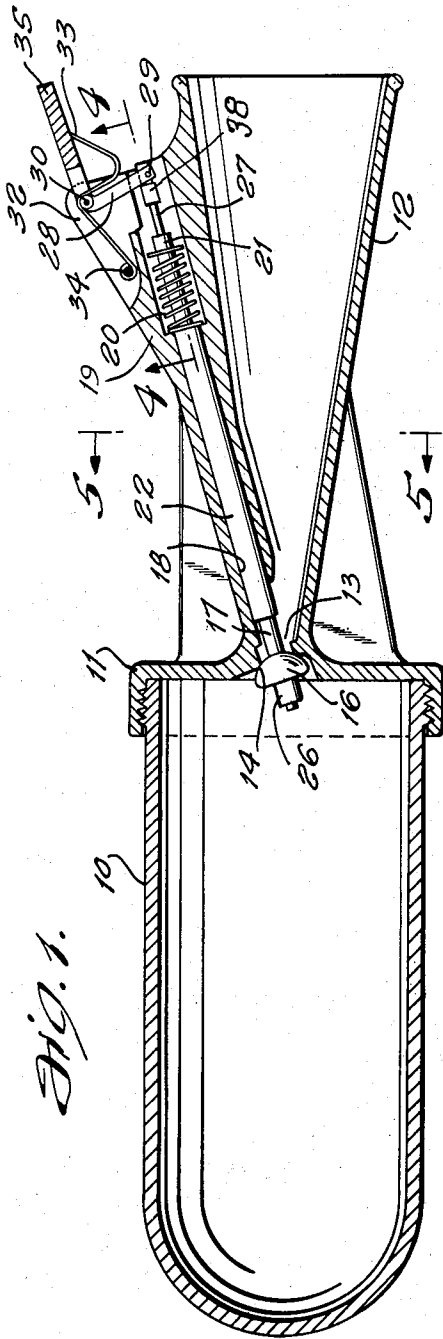
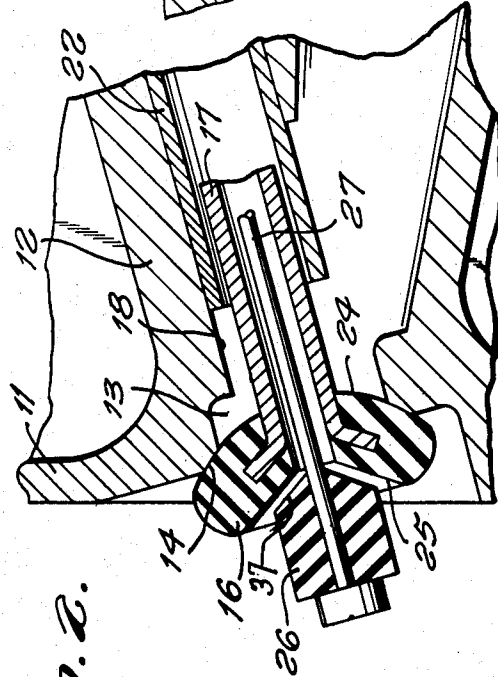

Fig. 3.



INVENTOR
GUSTAVE PODMORSKI
BY *Clark & Co.*
ATTORNEYS

May 15, 1956

G. PODMORSKI
PERSONAL RELIEF DEVICE

2,745,111

Filed May 13, 1953

2 Sheets-Sheet 2

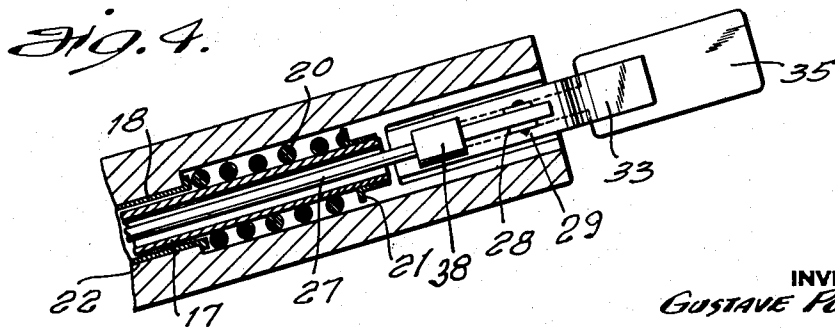
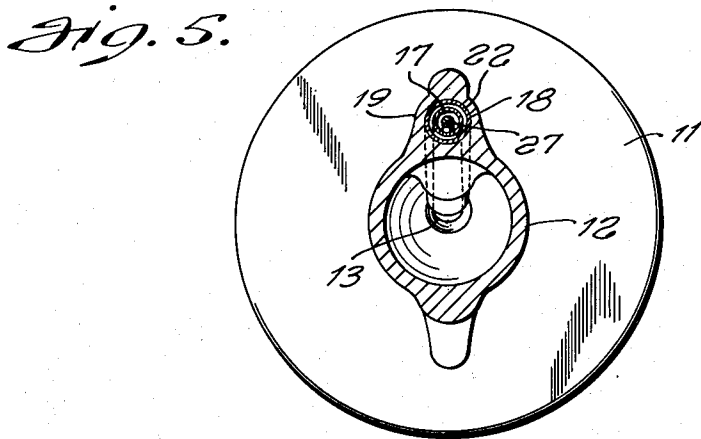
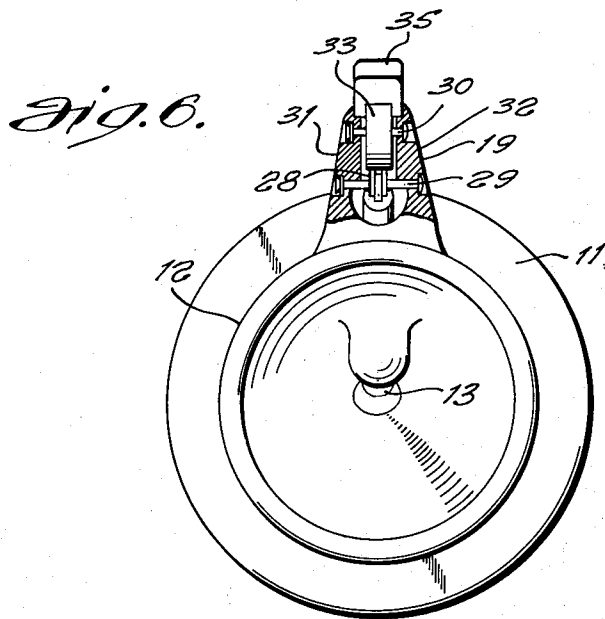

INVENTOR
GUSTAVE PODMORSKI
BY *Clark & Olt*
ATTORNEYS

1

2,745,111

PERSONAL RELIEF DEVICE

Gustave Podmorski, Lyndhurst, N. J., assignor to Air Associates, Inc., Teterboro, N. J., a corporation of New Jersey

Application May 13, 1953, Serial No. 354,839

3 Claims. (Cl. 4—110)

This invention relates to a personal relief device.

An object of the invention is to provide a personal relief device or urinarium which is sanitary and which is convenient for use by pilots of aircraft during flight.

Another object of the invention is to provide a device of said character which is maintained in closed relation at low and high altitudes and which is constructed for the venting or admission of air prior to use thereof.

In order that the device may be used at both low and high altitudes the invention provides a receptacle having an inlet opening and an air opening which are normally closed by valve means and are adapted to be successively opened for the venting or admission of air prior to the opening of the inlet.

Still another object of the invention is to provide a novel personal relief device which includes a funnel having concentric valve elements mounted for reciprocatory movement in a wall thereof and which normally maintain the air and inlet openings in closed relation and which valve elements are successively moved to open relation whereby air is admitted to or discharged from the receptacle prior to the opening of the inlet.

With the foregoing and other objects in view, reference is now made to the following specification and accompanying drawings in which the preferred embodiment of the invention is illustrated.

In the drawings:

Fig. 1 is a sectional view of a personal relief device constructed in accordance with the invention.

Fig. 2 is an enlarged fragmentary sectional view showing the inner ends of the valve elements and the inlet and air openings.

Fig. 3 is an enlarged fragmentary sectional view showing the upper ends of the valve stems and the tensioning means.

Fig. 4 is an enlarged fragmentary sectional view taken approximately on line 4—4 of Fig. 1.

Fig. 5 is an enlarged sectional view taken approximately on line 5—5 of Fig. 1.

Fig. 6 is an enlarged end view of the device with the pivotal connections of the lever for moving the valve elements shown in section.

Referring to the drawings by characters of reference, the device consists of a container 10 provided with a removable cover 11 threadedly secured to the top thereof. A funnel 12 is formed integrally with the cover 11 and is mounted centrally thereon with the bottom of the funnel opening through the cover and providing an inlet opening 13. The inlet opening 13 is formed with an annular seat 14 which is disposed in angular relation to the longitudinal axis extending centrally through the container and which opening is closed by a valve element 16 affixed to the inner end of a tubular stem 17 mounted for reciprocatory movement in a bore 18 in the enlarged portion 19 of the side wall of the funnel. The valve element 16 is tensioned to maintain the same in normally closed seated engagement on the seat 14 by means of a coiled spring 20 disposed in surrounding relation with the

2

tubular stem 17 and interposed between a flanged collar 21 affixed to the outer end of the stem and the upper end of a tubular sleeve 22 fitted in the bore 18 and through which the tubular stem 17 has reciprocatory movement.

The valve element 16 is formed of compressible resilient material such as rubber composition and the like and the same is of concavo-convex formation in cross-section and is secured to the stem 17 with the convex face 24 disposed outwardly for engagement with the annular seat 14 which is of concave formation conforming to the formation of the outer face 24 so as to provide a sealing engagement therewith when the valve element is in closed relation. The inner concave face 25 of the valve element 16 forms a valve seat for a valve member 26 affixed to the inner end of a stem 27 which extends through an air opening in the valve element 16 and through the tubular stem 17 with the outer end thereof pivotally connected to the outer end of a lever arm 28 on a pivot pin 29. The said lever arm is pivoted on a pivot pin 30 between the wall portions 31 and 32 formed integrally with the wall of the funnel and which is tensioned by a spring 33 engaging over said pivot and affixed at its inner end to a pin 34 extending laterally between said walls and with the outer end of said spring tensioned against a manipulating member 35 formed integrally with said lever arm. The spring 33 normally maintains the lever arm 28 in outward relation to dispose the valve member 26 in seated engagement on the valve element 16 for closing the air opening therethrough.

The valve member 26 is formed of compressible resilient material such as rubber composition and is provided with a tapered face 37 corresponding to the formation of the concave face 25 of the valve element 16 so that when the valve member 26 is seated on the valve element 16, the container is sealed against the admission or escape of air. The stem 27 is provided with an enlargement 38 at the outer end thereof which is adapted to engage the tubular stem 17 for moving said tubular stem together with the valve element 16 to dispose the said valve element in open relation with reference to the inlet.

It is to be understood that the air opening in the valve element 16 provides means for the equalization of the pressure of the air in the container with the pressure of the outside air. When the device is closed at a low altitude, the air pressure within the container will be relatively greater than the outside air when taken to a high altitude. Accordingly, if the device is then opened at a high altitude there will be a discharge of air through the air opening until the pressure within the container is equalized with that of the outside air. Also, if the device is closed at a high altitude and then taken to a low altitude, the air will be rarified with reference to the outside air. If the device is then opened at a low altitude, there will be a rapid admission of air into the container to equalize the air therein with the outside air pressure.

When the lever arm 28 is swung on its pivotal connection 30 to depress the stem 27, the valve member 26 will be moved to open relation with reference to the valve element 16 for the equalization of air pressure within the container. Further movement of the lever arm 28 will then cause the enlargement 38 to engage against the end of the tubular stem 17 to effect movement thereof so that the valve element 16 is moved to open relation with reference to the inlet.

What is claimed is:

1. In a portable device of the character described, a container having a cover removably secured thereto, a tubular member open at one end and affixed to the cover at the other end, said cover having an opening communicating with said tubular member and providing an inlet into the container, said tubular member having a

3

passageway extending lengthwise along a side wall of said tubular member and terminating inwardly within said tubular member outwardly of said inlet, a tubular stem mounted for reciprocatory sliding movement in said passageway and having a valve element affixed to the inner end thereof, means urging said tubular stem outwardly for normally retaining the valve element in closed relation with reference to said inlet, said valve element having an opening therethrough communicating with the interior of the tubular stem for the admission of air to and the venting of air from said container, a central stem mounted for reciprocatory movement in said tubular stem and having a valve member affixed to the inner end thereof, means urging said central stem outwardly for normally maintaining said valve member in closed relation with the opening in said valve element to seal the container against the entrance and escape of air, and means manually operable to move said central stem inwardly, successively first to open only said valve member to equalize air in the container with outside air, and second to open said valve element and thereby open said inlet.

5

10

15

20

4

2. The invention of claim 1, in which said manually operable means comprises a lever pivoted to the wall of said tubular member and to which said central stem is connected.

3. The invention of claim 1, said central stem having an enlargement adjacent the outer end thereof normally spaced outwardly from the outer end of said tubular stem but adapted to engage endwise with said outer end of said tubular stem when said central stem moves inwardly and thereafter to move said tubular stem inwardly.

References Cited in the file of this patent

UNITED STATES PATENTS

8,928	Schneider	May 4, 1852
482,578	Kiefer	Sept. 13, 1892
1,942,282	Green	Jan. 2, 1934
2,382,276	Wells	Aug. 14, 1945
2,534,997	Smith	Dec. 19, 1950
2,584,008	Fioretti	Jan. 29, 1952
2,584,216	Morrison	Feb. 5, 1952