

April 30, 1963

CARL-JOHAN BOMAN  
HORIZONTALLY NESTABLE CHAIRS

3,087,755

Filed July 6, 1961

3 Sheets-Sheet 1

fig.1

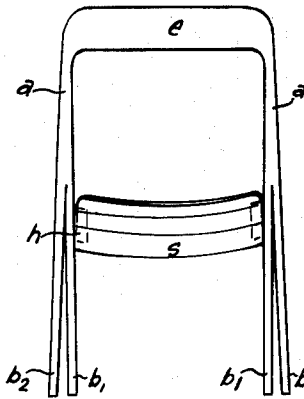

fig.2.

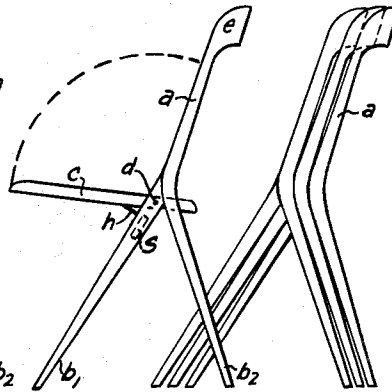

fig.5.

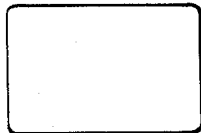

fig.7.

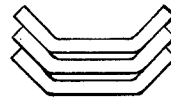

fig.6.

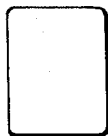

fig.8.



fig.3.

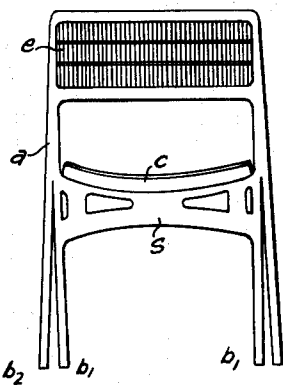
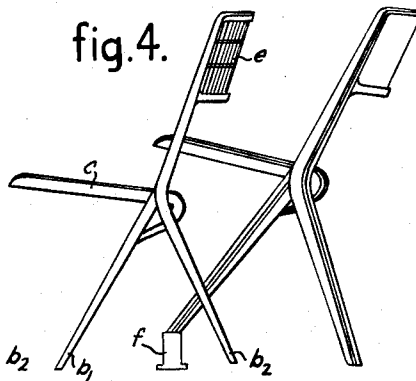

fig.4.



INVENTOR.

BY CARL-JOHAN BOMAN

*Robert H. Frost*

AGENT

April 30, 1963

CARL-JOHAN BOMAN  
HORIZONTALLY NESTABLE CHAIRS

3,087,755

Filed July 6, 1961

3 Sheets-Sheet 2

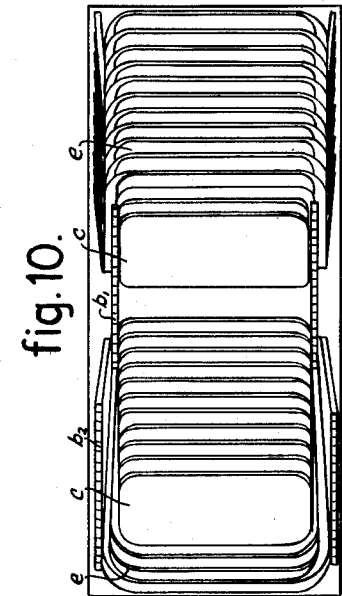

fig. 9.

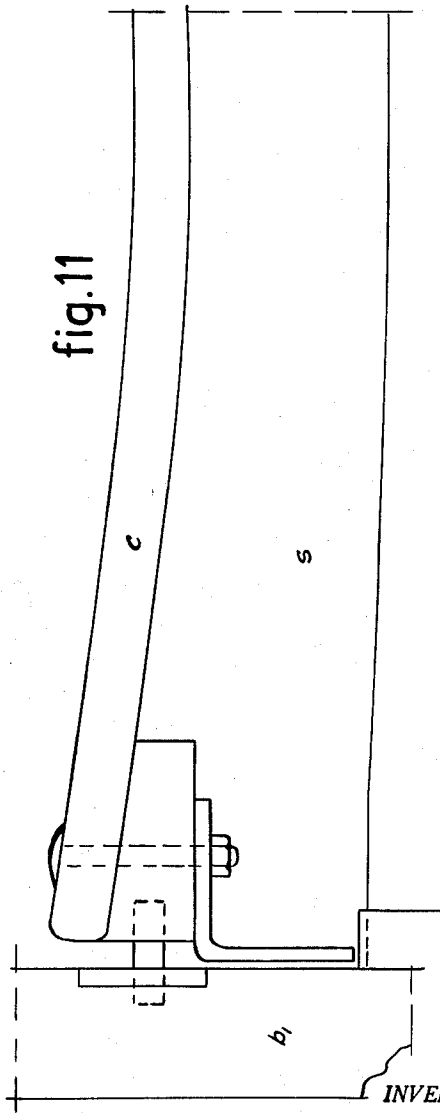
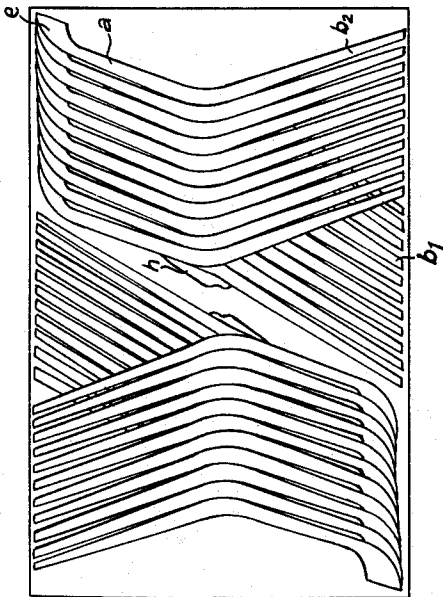

fig. 11

INVENTOR.  
CARL - JOHAN BOMAN  
BY  
*Robert H. Jacob*  
AGENT

April 30, 1963

CARL-JOHAN BOMAN  
HORIZONTALLY NESTABLE CHAIRS

3,087,755

Filed July 6, 1961

3 Sheets-Sheet 3

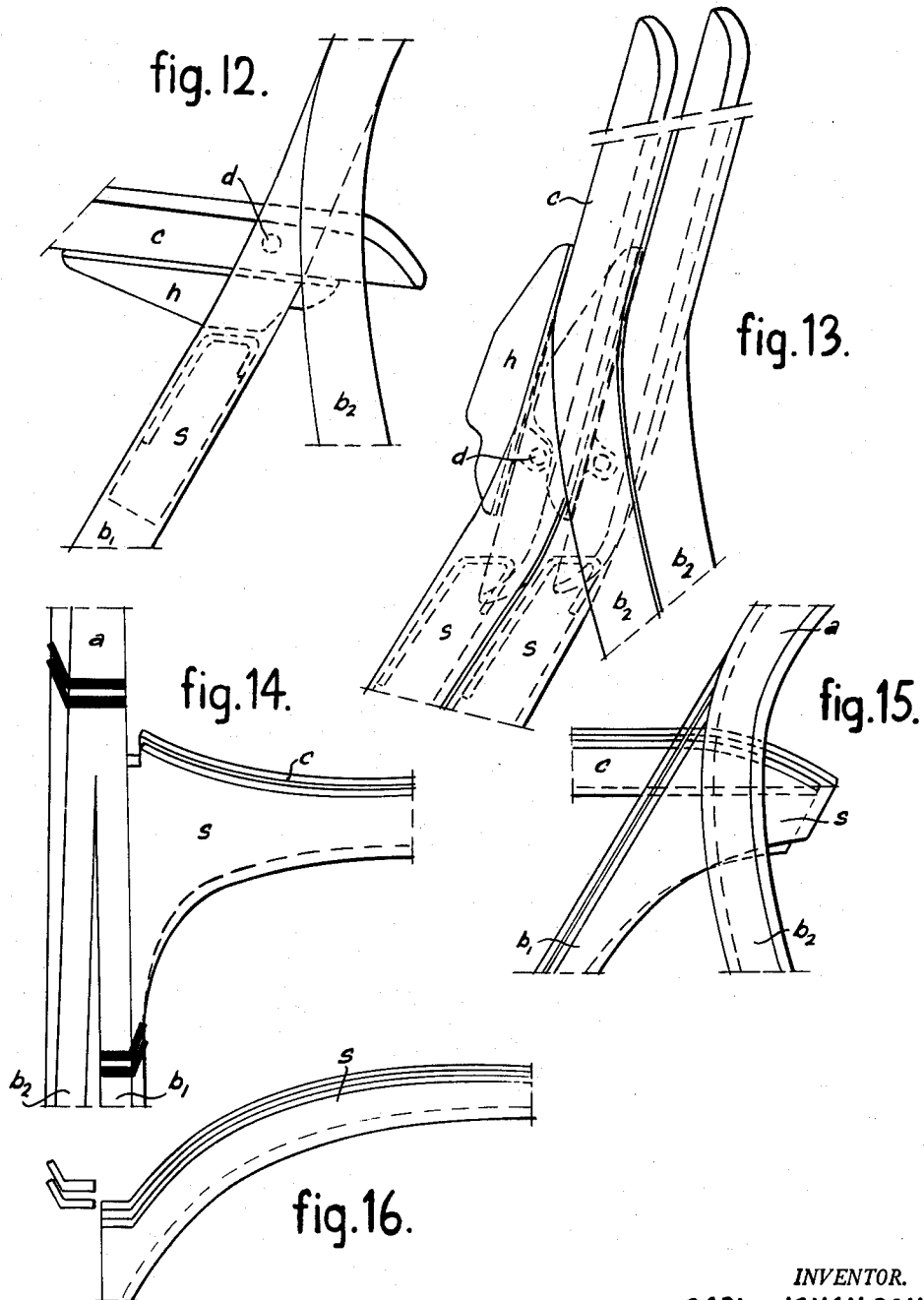

INVENTOR.  
CARL-JOHAN BOMAN  
BY  
*Robert H. Jacob*  
AGENT

1

3,087,755

**HORIZONTALLY NESTABLE CHAIRS**

Carl-Johan Boman, 77 Westendallen, Westend,  
Helsingfors, Finland

Filed July 6, 1961, Ser. No. 122,163

Claims priority, application Finland July 30, 1960

5 Claims. (Cl. 297-239)

There are two sorts of nestable chairs, i.e., vertically and horizontally nestable chairs. None of the prior known nestable chairs, however, utilize fully the available space.

As to the vertical nesting, this is extremely unfavourable, because the higher the stack is the bigger is the risk of its overturning and the more uncomfortable is the stacking itself. Furthermore, according to most designs the sloping of the chairs gradually moves backwards, which also reduces the height of the stack.

The horizontal nesting is no doubt preferable, but prior known chairs have when being stacked taken up too much room. This is mainly due to the fact that the legs, seat and frame each by itself increases the space and with prior known chairs it is possible to stack about 18-20 chairs at the utmost per square metre.

The object of the present invention is to improve the stacking possibilities in the horizontal plane. The invention is mainly characterized in that the front and hind legs of the chair have been made by dividing into two parts, seen from in front, the upper part of the chair, the outer part thus forming the rear legs and the inner part forming the front legs of the chair, and that this dividing takes place somewhat above the place where the seat has been arranged. By making the inner legs bent forwards and the outer legs backwards and by giving the parts of the chair that will touch each other when being stacked the same shape, dead space is eliminated. In accordance with the invention 50 chairs manufactured of wood can be placed within one square metre and if the chairs are manufactured of metal said number can be increased depending on the thickness of the material and the leg profile used. The structure of the chair in accordance with the invention is simple, comfortable and particularly suitable for extensive mass production and, seen from an industrial arts point of view, it has moreover simple and pure lines.

The chair is particularly suitable for assembly-rooms, schools, clubs, cafes, restaurants, dining-rooms, etc., but it is also excellent as a spare chair owing to its extremely small want of space.

The accompanying drawings show a preferred embodiment of the invention. In the drawings FIGURE 1 shows a front view of a chair manufactured of wood with a hinged seat, FIGURE 2 shows a side view of the same chair seen side-face. FIGURE 3 shows a front view of a chair manufactured of metal with a fixed seat, and FIGURE 4 is a side view of the same chair. FIGURE 5 shows a cross-section of the frame and FIGURE 6 a cross-section of the legs of a wooden chair taken from the front and the FIGURES 7 and 8 show a corresponding cross-section of a metal chair. FIGURE 9 is a side view illustrating the stacking of wooden chairs, 11 chairs being stacked in upright position and 11 chairs stacked in inverted position. FIGURE 10 shows the same stacking from the top, the rear legs of the chair lying outermost at the sides and the front legs within these. FIGURE 11 shows the seat seen from the front and a way of its fastening by means of fittings which are fixed directly to the seat. FIGURES 12 and 13 are side views of the seat with fittings, the seat being let down and the frame supporting the fittings in FIGURE 12, whereas FIGURE 13 shows two stacked chairs with folded seats,

2

the supporting parts of the fittings having free room for stacking. FIGURES 14 15 and 16 show details of two piled metal chairs, FIGURE 14 showing a front view of a part of the chair, FIGURE 15 showing a side view and FIGURE 16 parts of the frames of two piled chairs seen from the top.

In the various figures *a* is the upper part of the chair with the back-part *e*, *b*<sub>1</sub> are the front legs of the chair and *b*<sub>2</sub> the rear legs; *c* is the seat of the chair, which seat is either arranged elastically but firmly or foldable by means of hinges about pivots *d*. If the seat is foldable, it should be so dimensioned that there is room for it in the space between the upper parts *a* of the chair and the back-part *e*. If the seat is not foldable, it should be made to slope more or less backwards so that when the rearward chair is pushed forward against the front chair there is room for the seat of the rearward chair and it lies above the seat of the front chair. The frame or brace which extends between the front leg portions *b*<sub>1</sub> is marked by *s* and the seat support by *h*.

The required sloping can also be achieved by arranging under the front legs of the first chair detachable supports *f* or supports *f* which can be moved up and down. If the chairs are provided with foldable seats, such a support is not necessary, as in that case the seat does not prevent the stacking of the chairs, because, as previously mentioned, there is room for the seat in the space between the upper parts *a*, *a* and *e* of the chairs.

Owing to the fact that the legs, as shown in the drawings, have been divided, as from in front, into two parts *b*<sub>1</sub> and *b*<sub>2</sub>, where the dividing begins somewhat above the seat, and as the inner legs have been bent forwards and the rear legs backwards so that these legs as seen from the side are pyramidal, because every part of the chair that touches another part when the chairs are piled is so designed that the back side of each front chair part has the same shape and slopes as the front side of the back part of the chair, the smallest possible space in required for the stacked chairs. The space required for each chair in the stack corresponds on the whole to the thickness of the material used for manufacturing the chair.

The chair in accordance with the invention is not limited solely to the details of the forms described above, which may be modified, in order to meet various conditions and requirements encountered, without departing from the scope of the invention. The chair may for example be designed as a deck-chair with a fixed sloping seat, also provided with elbow-rests, which then must have the same slope as the seat, and even as a table if the upper part of the chair is removed and the movable seat is designed as a table-top.

What is claimed is:

1. Chair furniture for horizontal nesting comprising a plurality of chairs each having a back, a pair of side portions supporting said back, pairs of legs extending downwardly from each side portion and formed as split continuations of said side portions, each pair of legs comprising an outer rearwardly bent leg and an inner forwardly extending leg with the outer surfaces of the inner legs disposed substantially in a plane with the inner surfaces of the outer legs, and a seat portion mounted between and supported by said inner legs adjacent the lower ends of said side portions, said seat portion having a back part extending rearwardly of the upper ends of said outer legs, said back, said side portions and said legs of each chair having front surface portions corresponding generally to the rear surface portions of said back, said side portions and said legs, in a manner that in nested condition parts of said front surface portions of one chair are contacted by parts of the rear surface portions of an adjacent chair.

3

2. Chair furniture for horizontal nesting comprising a plurality of chairs each having a back, a pair of side portions supporting said back, pairs of legs extending downwardly from each side portion and formed as split continuations of said side portions, each pair of legs comprising an outer rearwardly bent leg and an inner forwardly extending leg with the outer surfaces of the inner legs disposed substantially in a plane with the inner surfaces of the outer legs, and a seat portion mounted between and supported by said inner legs adjacent the lower ends of said side portions, said seat portion having a back part extending rearwardly of the upper ends of said outer legs, said back, said side portions and said legs of each chair having front surface portions corresponding generally to the rear surface portions of said back, said side portions and said legs, in a manner that in nested condition parts of said front surface portions of one chair are contacted by parts of the rear surface portions of an adjacent chair, said side portions and said back defining an aperture therebetween and said seat being foldable, and in folded condition being received in said aperture.

3. Chair furniture for horizontal nesting comprising a plurality of chairs each having a back, a pair of side portions supporting said back, pairs of legs extending downwardly from each side portion and formed as split continuations of said side portions, each pair of legs comprising an outer rearwardly bent leg and an inner forwardly extending leg with the outer surfaces of the inner legs disposed substantially in a plane with the inner surfaces of the outer legs, and a seat portion mounted between and supported by said inner legs adjacent the lower ends of said side portions, said seat portion having a back part extending rearwardly of the upper ends of said outer legs, said back, said side portions and said legs of each chair having front surface portions corresponding generally to the rear surface portions of said back, said side portions and said legs, in a manner that in nested condition parts of said front surface portions of one chair are contacted by parts of the rear surface portions of an adjacent chair, said side portions and said back defining an aperture therebetween and said seat being foldable, and in folded condition being received in said aperture within the confines of the front plane and the rear plane in which said side portions are disposed.

4. Chair furniture for horizontal nesting comprising a plurality of chairs each having a back, a pair of side portions supporting said back, pairs of legs extending downwardly from each side portion and formed as split continuations of said side portions, each pair of legs comprising an outer rearwardly bent leg and an inner forwardly extending leg with the outer surfaces of the inner

4

legs disposed substantially in a plane with the inner surfaces of the outer legs, a seat portion mounted between and supported by said inner legs adjacent the lower ends of said side portions, said seat portion having a back part extending rearwardly of the upper ends of said outer legs, and a brace member extending between said front legs below said seat, said back, said side portions and said legs of each chair having front surface portions corresponding generally to the rear surface portions of said back, said side portions and said legs, in a manner that in nested condition parts of said front surface portions of one chair are contacted by parts of the rear surface portions of an adjacent chair.

5. Chair furniture for horizontal nesting comprising a plurality of chairs each having a back, a pair of side portions supporting said back, pairs of legs extending downwardly from each side portion and formed as split continuations of said side portions, each pair of legs comprising an outer rearwardly bent leg and an inner forwardly extending leg with the outer surfaces of the inner legs disposed substantially in a plane with the inner surfaces of the outer legs, a seat portion mounted between and supported by said inner legs adjacent the lower ends of said side portions, said seat portion having a back part extending rearwardly of the upper ends of said outer legs, and a brace member extending between said front legs below said seat, said back, said side portions and said legs of each chair having front surface portions corresponding generally to the rear surface portions of said back, said side portions and said legs, in a manner that in nested condition parts of said front surface portions of one chair are contacted by parts of the rear surface portions of an adjacent chair, said seat portion being rearwardly inclined and affording clearance thereunder for the seat of a chair nested below it from the front.

#### References Cited in the file of this patent

##### UNITED STATES PATENTS

40	1,879,126	Dellert -----	Sept. 27, 1932
	1,941,340	Dellert -----	Dec. 26, 1933
	1,989,426	Pollak -----	Jan. 29, 1935

##### FOREIGN PATENTS

45	275,548	Great Britain -----	Feb. 2, 1927
	147,761	Australia -----	Sept. 27, 1951
	675,916	Great Britain -----	July 16, 1952
	517,921	Belgium -----	Mar. 14, 1953
50	1,059,529	France -----	Nov. 10, 1953
	842,236	Great Britain -----	July 20, 1960