

(19) World Intellectual Property Organization
International Bureau



(43) International Publication Date
14 February 2002 (14.02.2002)

PCT

(10) International Publication Number
WO 02/13095 A2

- (51) International Patent Classification⁷: G06F 17/60 97007 (US). SMITH, John, R. [US/US]; 3202 N.E. 1st Place, Hillsboro, OR 97124 (US). PAAJANEN, George, E. [US/US]; 2314 Falcon Drive, West Linn, OR 97068 (US).
- (21) International Application Number: PCT/US01/24323
- (22) International Filing Date: 2 August 2001 (02.08.2001)
- (25) Filing Language: English
- (26) Publication Language: English
- (30) Priority Data:
60/223,289 3 August 2000 (03.08.2000) US
- (71) Applicant (for all designated States except US): UNICRU, INC. [US/US]; 9300 S.W. Nimbus Avenue, Beaverton, OR 97008 (US).
- (72) Inventors; and
- (75) Inventors/Applicants (for US only): SCARBOROUGH, David, J. [US/US]; 3715 Fairview Way, West Linn, OR 97068 (US). BECKER, Richard, W. [US/US]; 7954 S.W. 48th Avenue, Portland, OR 97219 (US). CHAMBLESS, Bjorn [US/US]; 1936 N.W. Raleigh #1, Portland, OR 97209 (US). CHECK, Thomas, F. [US/US]; 17670 S.W. Outlook Lane, Beaverton, OR 97007 (US). CLAINOS, Deme, M. [US/US]; 739 Terrace Drive, Lake Oswego, OR 97034 (US). ENG, Maxwell, W. [US/US]; 17094 N.W. Stoller Drive, Portland, OR 97229 (US). LEVY, Joel, R. [US/US]; 6124 S.W. Barnes Road, Portland, OR 97221 (US). MERTZ, Adam, N. [US/US]; 2825 N.E. 49th Avenue, Portland, OR 97213 (US). SMITH, David, R. [US/US]; 12041 S.W. Sagehen Street, Beaverton, OR
- (74) Agent: MAURER, Gregory, L.; Klarquist, Sparkman, LLP, One World Trade Center, Suite 1600, 121 SW Salmon Street, Portland, OR 97204 (US).
- (81) Designated States (national): AE, AG, AL, AM, AT, AU, AZ, BA, BB, BG, BR, BY, BZ, CA, CH, CN, CO, CR, CU, CZ, DE, DK, DM, DZ, EC, EE, ES, FI, GB, GD, GE, GH, GM, HR, HU, ID, IL, IN, IS, JP, KE, KG, KP, KR, KZ, LC, LK, LR, LS, LT, LU, LV, MA, MD, MG, MK, MN, MW, MX, MZ, NO, NZ, PL, PT, RO, RU, SD, SE, SG, SI, SK, SL, TJ, TM, TR, TT, TZ, UA, UG, US, UZ, VN, YU, ZA, ZW.
- (84) Designated States (regional): ARIPO patent (GH, GM, KE, LS, MW, MZ, SD, SL, SZ, TZ, UG, ZW), Eurasian patent (AM, AZ, BY, KG, KZ, MD, RU, TJ, TM), European patent (AT, BE, CH, CY, DE, DK, ES, FI, FR, GB, GR, IE, IT, LU, MC, NL, PT, SE, TR), OAPI patent (BF, BJ, CF, CG, CI, CM, GA, GN, GQ, GW, ML, MR, NE, SN, TD, TG).
- Published:
— with declaration under Article 17(2)(a); without abstract; title not checked by the International Searching Authority
- For two-letter codes and other abbreviations, refer to the "Guidance Notes on Codes and Abbreviations" appearing at the beginning of each regular issue of the PCT Gazette.



WO 02/13095 A2

(54) Title: ELECTRONIC EMPLOYEE SELECTION SYSTEMS AND METHODS

(57) Abstract:

ELECTRONIC EMPLOYEE SELECTION SYSTEMS AND METHODS

TECHNICAL FIELD

5 The invention relates to automated employee selection.

COPYRIGHT AUTHORIZATION

A portion of the disclosure of this patent document contains material that is subject to copyright protection. The copyright owner has no objection to the facsimile reproduction by anyone of the patent document or the patent disclosure, as it appears in
10 the Patent and Trademark Office patent file or records, but otherwise reserves all copyright rights whatsoever.

BACKGROUND

Organizations can spend considerable time and effort identifying and hiring
15 suitable employees. Good help is hard to find. Despite their best efforts, organizations still often meet with failure and simply accept high turnover and poor employee performance.

A variety of approaches to finding and hiring employees have been tried. A well-known tool for employee selection is the job application. Job applications help
20 identify a job applicant's qualifications, such as educational background, job history, skills, and experience.

An employer typically collects a set of job applications from applicants who drop by an employer work site or appear at a job fair. Someone in the organization then reviews the applications to determine which applicants merit further investigation.
25 Then, a job interview, a test, or some other review process is sometimes used to further limit the applicant pool.

With the advent of the electronic age, job applications can be completed electronically. In this way, the delays associated with processing paper can be minimized. However, even electronically-completed job applications can be of

questionable merit and still require considerable effort on the part of the hiring organization to review them. A better way of selecting employees is still needed.

SUMMARY

5 Large organizations can bring considerable resources to bear on the task of developing a job application. For example, a large retail chain might consult with an industrial psychologist to study the job environment and develop a set of questions that ostensibly predict whether an individual will excel in the environment.

 However, such an approach is fraught with inaccuracy and subjectivity; further,
10 the psychologist's analysis depends on conditions that may change over time. For example, even if the psychologist identifies appropriate factors for testing, an applicant might slant answers on the application based on what the applicant perceives is expected. Further, two psychologists might come up with two completely different sets of factors. And, finally, as the job conditions and applicant pool changes over time, the
15 factors may become less effective or ineffective.

 To determine whether a job application is effective, a study can be conducted to verify whether the factors chosen by the psychologist have been successful in identifying suitable applicants. However, such a study requires even more effort in addition to the considerable effort already invested in developing the application. So,
20 such a study typically is not conducted until managers in the organization already know that the application is ineffective or out of date.

 The disclosed embodiments include various systems and methods related to automated employee selection. For example, various techniques can be used to automate the job application and employee selection process.

25 In one aspect of an embodiment, answers to job application questions can be collected directly from the applicant via an electronic device. Based on correlations of the answers with answers to questions by other individuals for which post-hire information has been collected, a post-hire outcome is predicted.

In another aspect of an embodiment, an artificial-intelligence technique is used. For example, a neural network or a fuzzy logic system can be used to build a model that predicts a post-hire outcome. Proposed models of different types can be constructed and tested to identify a superior model.

5 When constructing a model, an information-theory-based feature selection technique can be used to reduce the number of inputs, thereby facilitating more efficient model construction.

 Items identified as ineffective predictors can be removed from the job application. Information collected based on the new job application can be used to build
10 a refined model. In this way, a system can exhibit adaptive learning and maintain its effectiveness even if conditions change over time. Content can be rotated or otherwise modified so the job application changes and maintains its effectiveness over time. Evolution toward higher predictive accuracy for employee selection can be achieved.

 A sample size monitor can identify when sufficient information has been
15 collected electronically to build a refined model. In this way, short-cycle criterion validation and performance-driven item rotation can be supported.

 Outcomes can be predicted for any of a wide variety of parameters and be provided in various formats. For example, tenure, number of accidents, sales level, whether the employee will be involuntarily terminated, whether the employee will be
20 eligible for rehire upon termination and other measures of employee effectiveness can be predicted. The prediction can be provided in a variety of forms, such as, for example, in the form of a predicted value, a predicted rank, a predicted range, or a predicted probability that an individual will belong to a group.

 Predictions can be provided by electronic means. For example, upon analysis of
25 a job applicant's answers, an email or fax can be sent to a hiring manager indicating a favorable recommendation regarding the applicant. In this way, real-time processing of a job application to provide a recommendation can be supported.

 Information from various predictors can be combined to provide a particularly effective prediction. For example, a prediction can be based at least on whether (or the

likelihood) the applicant will be involuntarily terminated and whether (or the likelihood) the applicant will be eligible for rehire upon termination. Based on whether the individual is predicted to both voluntarily quit and be eligible for rehire upon termination, an accurate measure of the predicted suitability of an applicant can be
5 provided.

Post-hire information can be based on payroll information. For example, termination status and eligibility for rehire information can be identified by examining payroll records. The payroll information can be provided electronically to facilitate a high-level of accurate post-hire information collection.

10 Further, reports can be provided to indicate a wide-variety of parameters, such as applicant flow, effectiveness of the system, and others.

Although the described technologies can continue to use the services of an industrial psychologist, relationships between pre-hire data predictors and desired job performance criteria can be discovered and used without regard to whether the
15 psychologist would predict such a relationship. A system using the described technologies can find relationships in data that may elude a human researcher.

Additional features and advantages of the various embodiments will be made apparent from the following detailed description of illustrated embodiments, which proceeds with reference to the accompanying drawings.

20 The present invention includes all novel and nonobvious features, method steps, and acts alone and in various combinations and sub-combinations with one another as set forth in the claims below. The present invention is not limited to a particular combination or sub-combination.

BRIEF DESCRIPTION OF THE DRAWINGS

25 Figure 1 is a block diagram showing exemplary pre-hire information collection.

Figure 2 is a block diagram showing a predictive model based on pre-hire and post-hire information.

Figure 3 is a block diagram showing ineffective predictors based on pre-hire and post-hire information.

Figure 4 is a block diagram showing refinement of a model over time.

Figure 5 is a flowchart showing a method for refining a model over time.

Figure 6 is a block diagram showing an exemplary system for providing employee suitability recommendations.

5 Figure 7 is a flowchart illustrating an exemplary method for providing employee suitability recommendations.

Figure 8 is a block diagram illustrating an exemplary architecture for providing employee suitability recommendations.

10 Figure 9 is a flowchart illustrating an exemplary method for building a predictive model.

Figure 10 is a block diagram showing an exemplary predictive model.

Figure 11 is a block diagram showing an exemplary refined predictive model.

Figure 12 is a block diagram illustrating integration of payroll information into a predictive system.

15 Figure 13 is a block diagram illustrating an exemplary combination of elements into a system.

Figures 14A-14D are block diagrams illustrating an exemplary process for implementing automated employee selection.

20 Figure 15 is a process flow diagram illustrating an exemplary process for an employment suitability prediction system.

Figure 16 is a graph illustrating exemplary effectiveness of a system over time.

Figure 17 is a graph illustrating entropy.

DETAILED DESCRIPTION

25 Overview of the Technologies

On a general level, the described technologies can include collecting information and building a model based on the information. Such a model can then be used to generate a prediction for one or more desired job performance-related criteria. The

prediction can be the basis of a hiring recommendation or other employee selection information.

Pre-hire information includes any information collected about an individual before the individual (e.g., a job applicant or other candidate) is hired. FIG. 1 shows a variety of sources 102 for collecting pre-hire information 112. The pre-hire information 112 can be stored in electronic (e.g., digital) form in a computer-readable medium (e.g., RAM, ROM, magnetic disk, CD-ROM, CD-R, DVD-ROM, and the like). Possible sources for pre-hire information 112 include a paper-based source 122, an electronic device 124, a third party service 126, or some other source 128. For example, pre-hire information can include an applicant's answers to an on-line employment application collected at a remote site, such as at an electronic device located in a kiosk at a prospective employer's work site. Further information and examples are described in "Example 2 - Collecting Information," below.

Post-hire information includes any information collected about an individual (e.g., an employee) after the individual is hired, including information collected while the employee is employed or after an employee is fired, laid off, or quits. Post-hire information can similarly be collected from a wide variety of sources. Post-hire information can include information about the employee's termination date. Further examples are described in "Example 2 - Collecting Information," below.

As shown in FIG. 2, after pre-hire information 212 and post-hire information 222 have been collected, a predictive model 232 can be built. As described in more detail below, a predictive model 232 can take a variety of forms, including artificial intelligence-based models. The predictive model can generate one or more predictions based on pre-hire information inputs. Thus, the model can be used to generate predictions for job applicants. In practice, the model can be implemented as computer-executable code stored in a computer-readable medium.

As shown in FIG. 3, after pre-hire information 312 and post-hire information 322 have been collected, ineffective predictors 332 can be identified. Such ineffective predictors can be ignored when constructing a model (e.g., the model 232 of FIG. 2). In

this way, the complexity of the model can be reduced, and the efficiency of the model construction process can be improved.

Further, the same ineffective predictors 332 or similar ineffective predictors can be removed from pre-hire content (e.g., ineffective questions can be removed from a job application). Identification of ineffective predictors can be achieved via software using
5 a variety of techniques; examples are described below.

As shown in FIG. 4, using various features described herein, a predictive model M_1 (412) based on pre-hire information PR_1 (414) and post-hire information PO_1 (416) can be refined. For example, information collection techniques can be refined by
10 removing pre-hire content identified as ineffective. Further, additional pre-hire content might be added (e.g., a new set of questions can be added to a job application).

As a result, new pre-hire information PR_2 (424) based on the refined pre-hire content can be collected. Corresponding post-hire information PO_2 (426) can be collected. Based on the information, a refined model M_2 (422) can be constructed.

The refinement process can be continued. For example, the effectiveness of the
15 additional pre-hire content can be determined. Thus, refinement can continue a number of times over time, resulting in pre-hire information PR_n (444), post-hire information PO_n (446), and a refined model M_n (442).

FIG. 5 shows an exemplary method for refining a predictive model. At 522, pre-
20 hire information for applicants is collected based on pre-hire content (e.g., predictors such as questions on an employment application or predictors collected from other sources). At 532, post-hire information for the applicants is collected. At 542 a predictive model is constructed. The model can be deployed and model output used for hiring recommendations. At 552, the pre-hire content can be refined (e.g., one or more
25 ineffective questions can be removed and one or new ones can be added). Then, additional pre-hire information can be collected at 522 (e.g., based on the refined pre-hire content). Eventually, a refined model can be generated.

The various models shown can be used as a basis for providing employee hiring recommendations. The architecture used to implement an electronic system providing

such employee hiring recommendations can vary from simple to complex. FIG. 6 shows an overview of an exemplary system 602. In the example, a computer-based electronic device 612 housed in a kiosk is situated in a work site (e.g., a retail store) and presents a job application to a job applicant via an electronic display 614. The
5 electronic device then sends the applicant's answers to a central server 622, which can also receive information from other electronic devices, such as the electronic device 624.

The server 622 can save the answers to a database 626 and immediately apply a predictive model to the answers to generate one or more predictions of employment
10 performance for the applicant and a hiring recommendation based on the predictions. Thus, real-time processing of incoming data can be accomplished.

The hiring recommendation can be immediately sent to a hiring manager's computer 642 via a network 652 (e.g., in an email via the Internet). Thus, real-time reporting based on incoming data can be accomplished. Although often less desirable,
15 delayed processing is also possible. Thus, alternatively, the system can, for example, queue information and send it out in batches (e.g., in a set of n applicants or every n days) as desired.

Various combinations and sub-combinations of the techniques below can be applied to any of the above examples.

20

Example 1 - Exemplary System and Method

FIG. 7 is a flowchart showing an exemplary method 702 for providing automated employee selection. At 712, questions are asked of an applicant such as via an electronic device. The answers are collected at 722. Based on the answers, a
25 prediction is generated at 732. Then, the results are provided at 742.

FIG. 8 is a block diagram an exemplary system 802 for providing employee selection. An electronic data interrogator 812 is operable to present a first set of a plurality of questions to an individual. An electronic answer capturer 822 is operable to

electronically store the individual's responses to at least a selected plurality of the first set of questions presented to the individual.

An electronic applicant predictor 832 is responsive to the stored answers and is operable to predict at least one post-hire outcome if the individual were to be employed
5 by the employer. The applicant predictor 832 can provide a prediction of the outcome based on correlations of the stored answers with answers to sets of the same questions by other individuals for which post-hire information has been collected. The predictor 832 can include a model constructed according to techniques described herein, such as in "Example 3 - Building a Predictive Model" and others.

10 An electronic results provider 842 can provide an output indicating the outcome to assist in determining the suitability of the individual for employment by an employer.

Some actions or elements might be performed or implemented by different parties and are therefore not necessarily included in a particular method or system. For example, collection of data might be performed by one organization, and another might
15 generate the prediction.

Example 2 - Collecting Information

As described with reference to FIG. 1 above, pre-hire information can be a variety of information collected from a variety of sources. One possible source for pre-
20 hire information is a paper-based collection source 122, such as a paper-based job application or test. Paper-based sources can be converted into electronic form by manual data entry or scanning.

Another possible source is an electronic device 124. Such an electronic device can, for example, be a computer, a computer-based kiosk, a screen phone, a telephone,
25 or a biometric device. For example, pre-hire content (e.g., a job application or skills test) can be presented to an applicant, who responds (e.g., answers questions) directly on the electronic device 124. Questions can be logically connected so that they are presented only if appropriate (e.g., if the employee answers affirmative to a question about termination, the device can then inquire as to the reason for termination).

Still another possible source for pre-hire information 112 is from a third party service 126. For example, credit reporting agencies, background check services, and other services can provide information either manually or over an online connection.

Yet another possible source for pre-hire information 112 is from another source
5 128. For example, later-developed technologies can be incorporated.

Any of the pre-hire information can be collected from a remote location (e.g., at a work site or from the applicant's home). The information 112 can then be stored in a central location, such as at an organization's information technology center or at an employment recommendation service's information technology center or a data
10 warehouse.

The pre-hire information 112 can be collected for an applicant when the applicant applies for a job or other times. For example, data may be obtained concerning individuals who have yet to apply for employment, such as from an employee job search web site or firm. The response data can then be used to predict the
15 probable job effectiveness of an applicant and the results of each prediction. Probable job effectiveness can be described, for example in terms of desired criteria and can include behavioral predictions.

The electronic device can be placed online in a variety of ways. For example, an external telecommunications data link can be used to upload applicant responses to a
20 host computer and download changes in pre-hire content, administration instructions, data handling measures, and other administration functions.

A modem connection can be used to connect via a telephone network to a host computer (e.g., central server), or a URL can be used to establish a web connection (e.g., via the Internet, an intranet, an extranet, and the like). Another network type (e.g.,
25 satellite) can be used. In this way, real-time data collection can be implemented.

The electronic device 124 can allow an applicant to enter text or numeric data or select from multiple response options, or register a voice or other biophysical response to a machine administered stimulus. The electronic device 124 can be programmable so that the presented content can be modified, and the presented content can be drawn from

a remote source. Such content can include text-based questionnaires, multi-media stimuli, and biophysical stimuli.

The electronic device 124 can, for example, include computer-readable media serving as memory for storing pre-hire content and administration logic as well as the applicant's response data. Alternatively, such content, logic, and responses can be stored remotely.

The device 124, as other examples, can include a standard computer interface (e.g., display, keyboard, and a pointing device), hand-held digital telecommunication devices, digitally enabled telephone devices, touch-screen kiosk delivery systems, multi-purpose electronic transaction processors such as Automated Teller Machines, travel reservation machines, electronic gaming machines, and biophysical apparatus such as virtual reality human interface equipment and biomedical devices.

Further, pre-hire information can include geographic elements, allowing geographical specialization (e.g., by region, county, state, country, or the like).

Post-hire information can similarly be collected in a variety of ways from a variety of sources, including evaluations, termination information, supervisor ratings, payroll information, and direct measures such as sales or units produced, number of accidents, and the like.

For example, after an employee has been on the job for a sufficient time, an evaluation can be made. Alternatively, upon termination of the employee, the employee's supervisor can rate the person's performance in an exit evaluation or the employee can complete an employee exit interview. Such collection can be accomplished by receiving answers to questions on an electronic device, such as the device 124 of FIG. 1.

Other available measures, such as length of service (e.g., tenure), sales, unit production, attendance, misconduct, number of accidents, eligibility for rehire after termination, and whether the employee was involuntarily terminated may also be collected. Generally, post-hire information is collected for post-hire outcomes for

which a prediction is desired. Such outcomes can, for example, include performance or job effectiveness measures concurrent with employment.

Example 3 - Building a Predictive Model

5 A variety of techniques can be used to build one or more predictive models for predicting post-hire outcomes for a job applicant. The model can take one or more inputs (e.g., pre-hire information) and generates one or more outputs (e.g., predicted post-hire outcomes). For example, a model can be based on artificial intelligence, such as a neural network, a structural equation, an information theoretical model, a fuzzy
10 logic model, or a neuro-fuzzy model.

FIG. 9 shows an exemplary method 902 for building a predictive model. At 912, information relating to inputs (e.g., pre-hire information) is collected. At 914, information relating to outputs to be predicted (e.g., post-hire information) is collected. Based on the inputs and outputs to be predicted, the model is built at 916.

15 When building a model, a variety of various proposed models can be evaluated, and one(s) exhibiting superior performance can be chosen. For example, various types of feed-forward neural networks (e.g., back propagation, conjugate gradients, quasi-Newton, Levenberg-Marquardt, quick propagation, delta-bar-delta, linear, radial basis function, generalized regression network [e.g., linear], and the like) can be built based
20 on collected pre- and post-hire data and a superior one identified and chosen. The proposed models can also be of different architectures (e.g., different number of layers or nodes in a layer). It is expected that other types of neural network types will be developed in the future, and they also can be used.

Similar techniques can be used for types of models other than neural networks.
25 In some cases, trial and error will reveal which type of model is suitable for use. The advice of an industrial psychologist can also be helpful to determine any probable interaction effects or other characteristics that can be accounted for when constructing proposed models.

Various commercially-available off-the-shelf software can be used for constructing artificial intelligence-based models of different types and architectures. For example, NEURALWORKS software (e.g., NEURALWORKS Professional II/Plus) marketed by NeuralWare of Carnegie, Pennsylvania and STATISTICA Neural
5 Networks software marketed by StatSoft of Tulsa, Oklahoma can be used. Any number of other methods for building the model can be used.

A model can have multiple outputs or a single output. Further, multiple models can be built to produce multiple predictions, such as predictions of multiple job performance criteria. Also, a model can be built to be geographically specialized by
10 building it based on information coming from a particular region, county, state, country, or the like.

Occupationally-specialized or education level-specialized models can also be constructed by limiting the data used to build the model to employees of a particular occupation or educational level.

15 One possible way of building a neural network is to divide the input data into three sets: a training set, a test set, and a hold-out set. The training set is used to train the model, and the test set is used to test the model and possibly further adjust it. Finally, the hold-out set is used as a measure of the model's ability to generalize learned pattern information to new data such as will be encountered with the model begins
20 processing new applicants. For example, a coefficient (e.g., 0.43) can be calculated to indicate whether the model is valid based on its ability to predict values of the hold-out set. Various phenomenon related to neural networks, such as over-training can be addressed by determining at what point during training the neural network indicates best performance (e.g., via a test set).

25 Identifying a superior model out of proposed models can be achieved by ranking the models (e.g., by measuring a validity coefficient for a hold-out set of data). During the ranking process, particular types (e.g., neural network or fuzzy logic) or architectures (e.g., number of hidden nodes) may emerge as fruitful for further exploration via construction of other, similar proposed models.

Example 4 - Identifying Ineffective Predictors

Ineffective (e.g., non-predictive or low-predictive) predictors can be identified.

5 For example, using an information-theory-based technique called “information transfer,” pre-hire content can be identified as ineffective. Generally, an ineffective predictor is a predictor that does not serve to effectively predict a desired job performance criterion. For example, answers to a particular question may exhibit a random relationship to a criterion and simply serve as noise in data.

10 One technique for identifying ineffective predictors is to consider various sets of permutations of predictive items (e.g., answers to job application questions A, B, C, A & B, A & C, B & C, and A & B & C) and evaluate whether the permutation set is effective. If an item is not in any set of effective predictors, the item is identified as ineffective. It is possible that while an item alone is ineffective, it is effective in
15 combination with one or more other items. Additional features of information transfer-based techniques are described in greater detail below.

After predictors are identified as ineffective, various actions can be taken, such as omitting them when constructing a model or removing corresponding questions from a job application. Or, an indication can be provided that information relating to such
20 predictors no longer need be collected.

Example 5 - Building a Model Based on Having Identified Ineffective Predictors

Predictors identified as ineffective can be ignored when building a model. In other words, one part of the model-building process can be choosing inputs for the
25 model based on whether the inputs are effective.

Reducing the number of inputs can reduce the complexity of the model and increase the accuracy of the model. Thus, a more efficient and effective model-building process can be achieved.

Example 6 - Exemplary Model

FIG. 10 shows a simple exemplary predictive model 1002 with predictive inputs IN_1 , IN_2 , IN_3 , IN_4 , and IN_5 . Various weights a_1 , a_2 , a_3 , a_4 , and a_5 can be calculated during model training (e.g., via back-propagation). The inputs are used in combination with the weights to generate a predicted value, OUT_1 . For example, the inputs might be answers to questions on a job application, and the predicted value might be expected job tenure.

A predictive model can estimate specific on-the-job behaviors that have been described for validation analysis in mathematical terms. Although a two-layer model is shown, other numbers of layers can be used. In addition, various other arrangements involving weights and combinations of the elements can be used. In fact, any number of other arrangements are possible.

Example 7 - Refining a Model

Predictors identified as ineffective can be removed from pre-hire content. For example, if a question on a job application is found to be an ineffective predictor for desired job performance criteria, the question can be removed from the job application. Additional questions can be added (these, too, can be evaluated and possibly removed later).

New pre-hire information can be collected based on the refined pre-hire content. Then corresponding new post-hire information can be collected. Based on the new information, a refined model can be built. Such an arrangement is sometimes called "performance-driven systematic rotation of pre-hire content."

In this way, questions having little or no value can be removed from an employment application, resulting in a shorter but more effective application. Predictive content can be identified by placing a question into the pool of questions and monitoring whether it is identified as ineffective when a subsequent model is constructed.

Model refinement can also be achieved through increased sample size, improvements to model architecture, changes in the model paradigm, and other techniques.

5 A system using the described refinement process can be said to exhibit adaptive learning. One advantage to such an arrangement is that the system can adapt to changing conditions such as changing applicant demographics, a changing economy, a changing job market, changes in job content, or changes to measures of job effectiveness.

10 **Example 8 - Exemplary Refined Model**

FIG. 11 shows a simple exemplary refined predictive model 1102. In the example, it was determined that IN_4 and IN_5 were ineffective predictors, so the content (e.g., question) related to IN_4 and IN_5 was removed from the corresponding employment application. Based on the finding that IN_4 and IN_5 were not effective predictors, they
15 were not included in the model deployed at that time. A set of new questions was added to the employment application.

When selecting new questions, it may be advantageous to employ the services of an industrial psychologist who can evaluate the job and determine appropriate job skills. The psychologist can then determine an appropriate question to be asked to identify a
20 person who will fit the job.

Subsequently, after pre-hire and post-hire information for a number of employees was collected, the new model 1102 was generated from the collected information. Two of the new questions were found to be effective predictors, so they was included in the refined model as IN_8 and IN_9 . IN_4 and IN_5 do not appear because
25 they had been earlier found to be ineffective predictors.

Example 9 - Prediction Types

A predictive model can generate a variety of prediction types. For example, a single value (e.g., "36 months" as a likely term of employment) can be generated. Or, a

range of values (e.g., “36-42 months” as a likely range of employment term) can be generated. Or, a rank (e.g., “7 out of 52” as how this applicant ranks in tenure as compared to 52 other applicants) can be generated.

Further, probabilities can be generated instead of or in addition to the above
5 types. For example, a probability that an individual will be in a certain range can be generated (e.g., “70% - 36 or more months”). Or, a probability of a certain value can be generated (“5% - 0 accidents”). Or, probability of membership in a group can be generated (e.g., “75% involuntarily terminated”).

Various combinations and permutations of the above are also possible. Values
10 can be whatever is appropriate for the particular arrangement.

Example 10 - Predicted Outcomes

Predicted post-hire outcomes can be any of a number of metrics. For example,
number of accidents, sales level, eligibility for rehire, voluntary termination, and tenure
15 can be predicted. There can be various models (e.g., one for each of the measurements)
or one model can predict more than one. The predicted outcomes can be job
performance criteria used when making a hiring recommendation.

Example 11 - Hiring Recommendation

20 After determining the suitability of the individual for employment by the
employer, based on one or more predictions generated by one or more models, a hiring
recommendation can be made. The recommendation can be provided by software.

The recommendation can include an estimate of future behavior and results can
be reported in behavioral terms. Alternatively, an employer might indicate the relative
25 importance of predicted outcome values, such as a specific set of job performance
criteria. Such information can be combined with generated predicted outcomes to
generate an overall score. Applicants having a score over a particular threshold, for
example, can be identified as favorable candidates. Further evaluation (e.g., a skills test
or interview) may or may not be appropriate.

Example 12 - Payroll-Based Information Collection

A problem can arise when collecting post-hire information. For example, it may be difficult to achieve high compliance rates for exit interviews. Also, collection of
5 information relating to termination dates and reasons for termination may be sporadic.

Post-hire information can be generated by examining payroll information. For example, a system can track whether an employee has been dropped from the payroll. Such an event typically indicates that the employee has been terminated. Thus, the employee's tenure can be determined by comparing the termination date with the
10 employee's hire date. Further, available payroll information might indicate whether an employee was voluntarily or involuntarily terminated and whether or not the employee is eligible for rehire and why the termination occurred. Still further, the payroll information can indicate a job change (e.g., a promotion).

Thus, much post-hire information can be commonly collected based on payroll
15 information, and a higher sample size can be achieved. An exemplary arrangement 1202 for collecting such information is shown in FIG. 12. In the example, the payroll information 1212 is accessible by a payroll server 1222. Communication with the payroll server 1222 can be achieved over a network 1242 (e.g., via the Internet or another network). The server 1242 receives information from the payroll server 1222
20 via the network 1232 (e.g., via any number of protocols, such as FTP, email, and the like). The information is then stored in the post-hire information database 1252. For example, payroll information can be scheduled for automatic periodic sending or may be sent upon initiation by an operator.

Although an online arrangement is shown, the information can also be provided
25 manually (e.g., via removable computer-readable media). In some cases, the information may need to be reformatted so it matches the format of other data in the database 1252.

Example 13 - Exemplary Implementations

In various implementations of the technologies, a computer-implemented system can be provided that collects pre-hire applicant information used to assess suitability for employment in specific jobs. The computer system can also collect post-hire measures
5 of the job effectiveness of employees hired using the system.

The pre-hire and post-hire information can then be converted and stored electronically as numeric data where such data can be logically quantified. Artificial intelligence technology and statistical analysis can be used to identify patterns within the pre-hire data that are associated with patterns of job effectiveness stored in the post-
10 hire data. Pre-hire data patterns with significant associations with different post-hire patterns are then converted to mathematical models (e.g., data handling routines and equations) representing the observed relationships.

Following the development of interpretive algorithms that operationalize the pattern relationships observed in a sample of complete employment cycles, the pre-hire
15 data collection system can then be re-programmed to run such interpretive formulas on an incoming data stream of new employment applications. Formula results can be interpreted as an estimate of the probable job effectiveness of new applicants for employment based on response pattern similarity to others (e.g., employees). Interpretive equation results can be reported in behavioral terms to hiring managers who
20 can use the information to identify and hire those applicants whose estimated job performance falls within an acceptable range.

The system can be capable of adaptive learning, or the ability to modify predictive models in response to changing data patterns. Adaptive learning can be operationalized using artificial intelligence technologies, short cycle validation
25 procedures and performance-driven item rotation. The validation cycle can be repeated periodically as new employment histories are added to the database. With successive validation cycles, pre-hire predictor variables that have little or no relationship to job effectiveness can be dropped. New item content can replace the dropped items. Predictive variables can be retained and used by interpretive algorithms until sufficient

data has accumulated to integrate the new predictors into the next generation interpretive algorithm. The outdated algorithm and associated records can be archived and the new model deployed. Adaptive learning can enable evolutionary performance improvement, geographic specialization, and shorter, more accurate pre-hire
5 questionnaires.

Example 14 - Criterion Validation

Criterion validation includes discovering and using measures of individual differences to identify who, out of a group of candidates, is more likely to succeed in a
10 given occupation or job. Individual differences are measures of human characteristics that differ across individuals using systematic measurement procedures. Such measures include biographic or life history differences, standardized tests of mental ability, personality traits, work attitudes, occupational interests, work-related values and beliefs, and tests of physical capabilities, as well as traditional employment-related information,
15 such as employment applications, background investigation results, reference checks, education, experience, certification requirements, and the like.

Criterion validation includes the research process used to discover how these measures of individual differences relate to a criterion or standard for evaluating the effectiveness of an individual or group performing a job. Typical measures of job
20 effectiveness include performance ratings by managers or customers, productivity measures such as units produced or dollar sales per hour, length of service, promotions and salary increases, probationary survival, completion of training programs, accident rates, number of disciplinary incidents or absences, and other quantitative measures of job effectiveness. Any of these measures of job effectiveness and others (e.g., whether
25 an applicant will be involuntarily terminated, and the like) can be predicted via a model.

Pre-hire metrics, including those listed above, called predictors, can be analyzed in relation to each criterion to discover systematic co-variation. A common statistic used to summarize such relationships is the Pearson Product Moment Correlation coefficient, or simply the validity coefficient. If a predictor measure is found to

correlate with a criterion measure across many individuals in a validation sample, the predictor is said to be “valid,” that is predictive of the criterion measure. Valid predictors (e.g., pre-hire information) that correlate with specific criteria, such as post-hire measures (e.g., including concurrent performance measures) are then used in the evaluation of new candidates as they apply for the same or similar jobs. Individual differences in temperament, ability, and other measures can have profound and measurable effects on organizational outcomes.

In employee selection, an independent (e.g., “predictor”) variable can be any quantifiable human characteristic with a measurable relationship to job performance. Physical measurements, intelligence tests, personality inventories, work history data, educational attainment, and other job-related measures are typical. The dependent (e.g., “criterion”) variable can be defined as a dependent or predicted measure for judging the effectiveness of persons, organizations, treatments, or predictors of behavior, results, and organizational effectiveness.

In general, measures of job performance include objective numeric data, such as absenteeism, accident rates, unit or sales productivity can be readily verified from direct observation and are sometimes called “hard” measures. Objective measures of job performance may be available for only a small set of narrowly-defined production and other behaviorally-specific jobs. In the absence of hard measurement, opinion data such as performance ratings by managers can be used for the same purpose.

Establishing the criterion validity of a selection test or group of tests can include informed theory building and hypothesis testing that seeks to confirm or reject the presence of a functional relationship.

Example 15 - Artificial Intelligence Techniques

Artificial intelligence can attempt to simulate human intelligence with computer circuits and software. There are at least three approaches to machine intelligence: expert systems, neural networks, and fuzzy logic systems. Expert systems can capture knowledge of human experts using rule-based programs to gather information and make

sequential decisions based on facts and logical branching. These systems involve human experts for constructing the decision models necessary to simulate human information processing. Expert systems can be used to standardize complex procedures and solve problems with clearly defined decision rules.

5 Neural networks (also commonly called “neural systems,” “associative memories,” “connectionist models,” “parallel distributed processors,” and the like) can be computer simulations of neuro-physiological structures (e.g., nerve cells) found in nature. Unlike expert systems, artificial neural networks can learn by association or experience, rather than being programmed. Like their biological counterparts, neural
10 networks form internal representations of the external world as a result of exposure to stimuli. Once trained, they can generalize or make inferences and predictions about data that they have not been exposed to before. Neural networks are able to create internal models of complex, nonlinear multivariate relationships, even when the source data is noisy or incomplete. It is this capacity to function with uncertain or fuzzy data
15 that makes a neural processor valuable in the real world.

Fuzzy computation includes a set of procedures for representing set membership, attributes, and relationships that cannot be described using single point numeric estimates. Fuzzy systems can allow computers to represent words and concepts such as vagueness, uncertainty, and degrees of an attribute. Fuzzy systems can allow computers
20 to represent complex relationships and interactions between such concepts. They can also be a useful tool for describing human attributes in terms that a computer can process. Fuzzy concepts and fuzzy relationship models can be used in an employee selection system to represent predictor-criterion interactions when such relationships are supported by analysis of the available data.

25 Neuro-fuzzy technology is a hybrid artificial intelligence technique employing the capabilities of both neural network learning and fuzzy logic model specification. In an employee selection system, predictor-criterion relationships can be described initially as a fuzzy model and then optimized using neural network training procedures. In the

absence of evident explanatory predictor-criterion relationships, unspecified neural networks can be used until such relationships can be verified.

Genetic algorithms can represent intelligent systems by simulating evolutionary adaptation using mathematical procedures for reproduction, genetic crossover, and mutation. In an employee selection system, genetic algorithm-based data handling routines can be used to compare the prediction potential of various combinations of predictor variables to optimize variable selection for model development.

Information theoretic based feature selection can be based on information theory. Such a technique can use measures of information transmission to identify relations between independent and dependent variables. Since information theory does not depend on a particular model, relation identification is not limited by the nature of the relation. Once the identification process is complete, the set of independent variables can be reduced so as to include only those variables with the strongest relationship to the dependent variables.

Such a pre-filtering process facilitates the modeling process by removing inputs which are (e.g., for the most part) superfluous and would therefore constitute input noise to the model. A reduction in the dimensionality of the input vector to the model also reduces the complexity of the model and in some cases (e.g., neural networks), greatly reduces the computational expense involved in model generation.

Information theoretic-based modeling techniques such as reconstructability analysis can be used in an employee selection system. Such techniques use informational dependencies between variables to identify the essential relations within a system. The system is then modeled by reproducing the joint probability distributions for the relevant variables. The benefits of such modeling techniques include that they do not depend on a model and can emulate both deterministic and stochastic systems.

An employee selection system can include adaptive learning technology. Such a system can be constructed as a hybrid artificial intelligence application, based in part on various (or all) of the above artificial intelligence technologies. Expert systems can be employed to collect and process incoming and outgoing data, transfer data between sub-

systems internally and in model deployment. Neural networks can be used for variable selection, model development, and adaptive learning. Fuzzy set theory, fuzzy variable definition, and neuro-fuzzy procedures can be used in variable specification, model definition, and refinement. Genetic algorithm techniques can be used in variable
5 selection, neural network architecture configuration and model development and testing. Information theoretic feature selection and modeling techniques can be used in data reduction, variable selection, and model development.

Example 16 - Electronic Repository System

10 Externally-collected data can be sent to an in-bound communications sub-system that serves as a central repository of information. Data can be uploaded via a variety of techniques (e.g., telephone lines, Internet, or other data transfer mechanisms). The in-bound communications sub-system can include a set of software programs to perform various functions.

15 For example, the sub-system can receive incoming data from external data collection devices. The incoming data can be logged with a date, time and source record. Data streams can be stored to a backup storage file.

After data reception, the subsystem can respond to the source device with a text message indicating that transmission was successful or unsuccessful; other messages or
20 instructions can be provided. The data stream can be transferred to a transaction monitor (e.g., such as that described below) for further processing.

The subsystem can also download machine-specific executable code and scripting files to external data collection devices when changes to the user-interface are desired. The download transmissions can be logged by date, time, and status and the
25 external device's response recorded.

Example 17 - Transaction Monitor

A transaction monitor can serve as an application processing system that directs information flow and task execution between and among subsystems. The transaction

monitor can classify incoming and outgoing data streams and launch task-specific sub-routines using multi-threaded execution and pass sub-routine output for further processing until transactions (e.g., related to data streams) have been successfully processed.

- 5 A transaction monitor can perform various functions. For example, the transaction monitor can classify data streams or sessions as transactions after transmission to an in-bound communications sub-system. Classification can indicate the processing tasks associated with processing the transaction.

10 Data can be parsed (e.g., formatted into a pre-defined structure) for additional processing and mapped to a normalized relational database (e.g., the applicant database described below). Data elements can be stored with unique identifiers into a table containing similar data from other sessions.

15 Session processing task files can be launched to process parsed data streams. For example, an executable program (e.g., C++ program, dynamic link library, executable script, or the like) can perform various data transmission, transformation, concatenation, manipulation or encoding tasks to process the sessions.

20 Output from session processing tasks can then be formatted for further processing and transmission to external reporting devices (e.g., at an employer's site). For example, the imaging and delivery sub-system described below can be used.

Example 18 - Applicant Database

25 A relational database can store pre- and post- employment data for session transactions that are in process or were received and recently processed. As individual session records age, they can be systematically transferred to another storage database (e.g., the reports database described below).

 Both databases can consist of electronically-stored tables made up of rows and columns of numeric and text data. In general, rows contain identifier keys (e.g., unique keys) that link elements of a unique session to other data elements of that session. Columns can hold the component data elements. Unique session data can be stored

across many tables, any of which may be accessed using that session's unique identification key.

An arrangement of three basic types of data can be used for the applicant database. First, standard pre-hire application information (e.g., name, address, phone number, job applied for, previous experience, references, educational background, and the like) can be stored. Also, included can be applicant responses to psychological or other job-related assessments administered via an external data collection device (e.g., the electronic device 124 of FIG. 1).

Second, post-hire data about the job performance of employees after being hired can be stored. Such data can include, for example, supervisor opinion ratings about the employee's overall job performance or specific aspects of the employee's job effectiveness. Quantitative indicators about attendance, sales or unit production, disciplinary records and other performance measures may also be collected.

Third, employer-specific information used to process transactions can be stored. Such data can include information for sending an appropriate electronic report to a correct employer location, information related to downloading user interface modifications to specific data collection devices, and information for general management of information exchange between various sub-systems. For example, employer fax numbers, URL's, email accounts, geographic locations, organizational units, data collection unit identifier, and the like can be stored.

Other information or less information can be stored in the database. Further, the database may be broken into multiple databases if desired.

Example 19 - Reports Database

A reports database can be a relational database serving as a central repository for records processed by the applicant database. Applicant records for applicants not hired can be deleted. Applicant records for applicants aged over a certain client-specified record retention time limit can be deleted.

The reports database can be used as a source for the data used in generating, printing, or posting corporate reports (e.g., such as those described below). Such data can include client-specific records of employment applications received for recent reporting periods, plus pre-hire predictor and post-hire criterion performance data.

5

Example 20 - Corporate Reports

Useful information can be collected in the course of operating a hiring recommendation system. For example, information about applicant flow, hiring activity, employee turnover, recruiting costs, number of voluntary terminations, applicant and employee characteristics and other employee selection metrics can be collected, stored, and reported.

10

Standardized reports can be provided to employers via printed reports, fax machines, email, and secure Internet web site access. Source data can come from the reports database described above. Custom reports can also be generated.

15

Example 21 - Sample Size Monitor

A sample size monitor can be provided as a computer program that monitors the quality and quantity of incoming data and provides an indication when a sufficient number or predictor-criterion paired cases have accumulated. For example, employer-specific validation data can be transferred to a model development environment upon accumulation of sufficient data.

20

The program can use an expert system decision rule base to keep track of how many complete employee life cycle histories are in a reports database. In addition, the software can examine and partition individual records that may be unusable due to missing fields, corrupted data, or other data fidelity problems. Using pre-defined sample size boundaries, the software can merge available pre- and post-hire data transfer and transfer a file to the validation queue (e.g., the queue described below).

25

Example 22 - External Service Providers

A system can interface with other online data services of interest to employers. Using a telecommunication link to third party service computers, a transaction monitor can relay applicant information to trigger delivery of specialized additional pre-hire data which can then be added to an applicant database and used in subsequent analysis and reporting. Such services can include, for example, online work opportunity tax credit (WOTC) eligibility reporting, online social security number verification, online background investigation results as indicated by specific jobs, and psychological assessment results, including off-line assessment. Such services are represented in FIG. 1 as the third party service 126.

Example 23 - Validation Queuing Utility

Validation queuing utility software can be provided to serve as a temporary storage location for criterion validation datasets that have not yet been processed in a model development environment (e.g., such as that described below). Datasets can be cataloged, prioritized, and scheduled for further processing using predefined decision rules. When higher priority or previously-queued datasets have been processed, the file can be exported to the analysis software used for model development.

Example 24 - Model Development Technique

Model development can result in the creation of a model that represents observed functional relationships between pre-hire data and post-hire data. Artificial intelligence technologies can be used to define and model such relationships. Such technologies can include expert systems, neural networks and similar pattern function simulators, fuzzy logic models, and neuro-fuzzy predictive models.

Various procedures can be implemented. For example, the distribution of pre-hire variables (sometimes called "independent" or "predictor variables") can be analyzed in relation to the distribution of post-hire outcome data (sometimes called "dependent" or "criterion variables").

Using statistical and information theory derived techniques, a subset of predictor variables can be identified that show information transfer (e.g., potential predictive validity) to one or more criterion variables.

5 An examination of joint distributions may result in the formalization of a fuzzy theoretical model and certain predictors may be transformed to a fuzzy variable format.

If an obvious theoretical model does not emerge from this process, the remaining subset of promising variables can be categorized and transformed for neural network training. Non-useful (e.g., ineffective) predictor variables can be dropped from further analysis.

10 The total sample of paired predictor-criterion cases (e.g., individual employee case histories) can be segmented into three non-overlapping sub-samples with group membership being randomly defined. Alternate procedures, such as randomized membership rotation may also be used to segment the data.

15 A training set can be used to train a neural network or neuro-fuzzy model to predict, classify, or rank the probable criterion value associated with each instance of predictor input variables. A test set can be used to evaluate and tune the performance (e.g., predictive accuracy) of models developed using the training set. A hold-out or independent set can be used to rank trained networks by their ability to generalize learning to unfamiliar data. Networks with poor predictive accuracy or low
20 generalization are dropped from further development.

Surviving trained models can then be subjected to additional testing to evaluate acceptability for operational use in employee selection. Such testing can include adverse impact analysis and selection rate acceptability.

25 Adverse impact analysis can evaluate model output for differential selection rates or bias against protected groups. Using independent sample output, selection rates can be compared across gender, ethnicity, age, and other class differences for bias for or against the groups. Models which demonstrate differential prediction or improper bias can be dropped from further development.

Selection rate acceptability can include evaluation of selection rates for hire/reject classification models. Selection rates on the independent sample can be evaluated for stringency (e.g., rejects too many applicants) or leniency (e.g., accepts too many applicants) and models showing these types of errors can be dropped.

5 Final candidate networks can be ranked according to their performance on test parameters, and the single best model can be converted to a software program for deployment in a live employee selection system. The coded program can then be passed to the deployment and archiving modules (e.g., such as those described below).

Such an iterative process can be repeated as different predictor-criterion
10 relationships emerge. As sufficient data accumulates on specific criterion outcomes, additional predictive models can be developed. Older models can eventually be replaced by superior performing models as item content is rotated to capture additional predictive variation (e.g., via the item rotation module described below). Sample size can continue to increase. Thus, a system can evolve toward higher predictive accuracy.

15

Example 25 - Model Deployment Technique

Deployment of a model can include a hiring report modification and model insertion. The hiring report modification can include modifications to an imaging and delivery subsystem and an applicant processing system (e.g., the above-described
20 transaction monitor).

To facilitate employer use of model predictions, numeric output can be translated into text, number, or graphics that are descriptive of the behavior being predicted. Output can be presented to an employer in behavioral terms.

When a criterion to be predicted is a number, the exact numeric estimate can be
25 couched in a statement or picture clearly describing the predicted behavior. For example, if the model has produced an estimate of an applicant's probable length of service in days, the hiring report can be modified to include a statement such as the following example:

Based on similarity to former employees, this applicant's estimated length of service is X days, plus or minus Y days margin of error.

- 5 X can be the specific number of days that the trained predictive model has provided as an estimate of the applicant's probable length of services, and Y can be the statistical margin of error in which the majority of cases will tend to fall.

When the criterion to be predicted is group membership (e.g., whether or not the applicant is likely to belong to a specific group), the model estimate may be expressed
10 as a probability, or likelihood, that the applicant will eventually be classified in that group. For example, if the predictive model has been trained to classify employee response patterns according to the probability that they would be eligible for rehire instead of not being eligible for rehire upon termination, a statement or graphic similar to the following example can be presented on a hiring report:

15 *Based on similarity to former and/or current employees, this applicant's probability of being eligible for rehire upon termination is X percent.*

X can be a probability function expressed as a percentage representing the number of
20 chances in one hundred that the particular applicant will be eligible for rehire when he or she leaves the company.

When the criterion produced is a ranking or relative position in a ranked criterion, text or graphic images can be used to convey the applicant's position in the criterion field. For example, if the model has produced an estimate of the probable rank
25 of a sales employee's annual sales volume compared to past sales employees, a statement similar to the following example might be used:

30 *Based on similarity to former sales employees, this applicant is likely to produce annual sales in the top Xth (e.g., third, quarter, fifth, or the like) of all sales employees.*

X can refer to the ranking method used to classify the criterion measure.

Such text-based reporting methods as described above can be summarized, illustrated with, appended to, or replaced by graphic images representing the behavioral

information. For example, charts, graphs, images, animated images, and other content format can be used.

Applicant processing system model insertion can be accomplished by embedding a coded model in the application processing conducted by a transaction monitor after the format of the predictive output has been determined. Data handling routines can separate model input variables from the incoming data stream. The inputs can be passed to the predictive model and be processed. The output of the model can then be inserted or transformed into a reporting format as described above and added to a hiring report transmission.

10

Example 26 - Validation Archives

As a new model is deployed, the replaced model can be transferred to an archive storage. The archive can also record applicants processed by the old model. Such an archive can be useful if reconstruction of results for a decommissioned model is desired for administrative or other reasons.

15

Example 27 - Exemplary Item Rotation Technique

An item rotation module can be implemented as a software program and database of predictor item content. The item rotation module can be used to systematically change pre-hire content so that useful predictor variables are retained while non-useful (e.g., ineffective) predictors can be replaced with potentially useful new predictors.

20

Adaptive learning includes the ability of a system to improve accuracy of its behavioral predictions with successive validation cycles. Iterative neural network and neuro-fuzzy model development and performance-driven item rotation can be used to facilitate adaptive learning.

25

As part of a validation analysis for a model, predictor variables (e.g., pre-hire questions or items) predictive of a criterion measure can be identified. At the same

time, other predictors with little or no modeling utility (e.g., ineffective predictors) can be identified.

Performance-driven item rotation includes the practice of systematically retaining and deleting pre-hire content so that item content with predictive utility continues to serve as input for behavioral prediction with the current predictive model and items with little or no predictive utility are dropped from the content. New, experimental item content can be inserted into the content and response patterns can be recorded for analysis in the next validation cycle.

Such rotation is shown in Tables 1 and 2.

10

Table 1 – Item Content During Validation Cycle #1

Item	Status
You help people a lot	Ineffective
You tease people until they get mad	Ineffective
You have confidence in yourself	Effective
You would rather not get involved in other's problems	Ineffective
Common sense is one of your greatest strengths	Ineffective
You prefer to do things alone	Effective
You have no fear of meeting people	Effective
You are always cheerful	Ineffective
24 x 7 = ?	Ineffective
You get mad at yourself when you make mistakes	Ineffective
How many months were you at your last job?	Effective

Table 2 – Item Content After Validation Cycle #1

Item	Status
Many people cannot be trusted	New experimental item
You are not afraid to tell someone off	New experimental item
You have confidence in yourself	Effective – retained
You try to sense what others are thinking and feeling	New experimental item

You attract attention to yourself	New experimental item
You prefer to do things alone	Effective – retained
You have no fear of meeting people	Effective – retained
You can wait patiently for a long time	New experimental item
You say whatever is on your mind	New experimental item
Background check item	New experimental item
How many months were you at your last job?	Effective – retained

The content shown in Table 1 has been refined to be that shown in Table 2, based on the effectiveness of the predictor items. New experimental items have been added, the effectiveness of which can be evaluated during subsequent cycles.

5 As successive validation cycles are completed and non-predictive item content is systematically replaced with predictive item content, overall validity improves. After multiple validation cycles, the result can be a shorter pre-hire questionnaire comprised of currently-performing predictive input and a few experimental items being validated in an on-going process for system evolution toward higher predictive accuracy.

10

Example 28 - Imaging and Delivery Subsystems

Imaging and delivery subsystems can assemble input from applicant processing to create an electronic image that resembles a traditional employment application that can be transmitted to an employer’s hiring site via external data devices (e.g., fax
 15 machine, computer with email or web access, hand-held devices, digitally enabled telephones, printers, or other text/graphics imaging devices). Hiring reports can also be delivered as hard copy via mail or other delivery services.

Example 29 - Hire Site Report Reception

20 Hiring managers can receive an electronic report that can be printed or simply saved in electronic format. The entire application process can occur in real-time or

validation cycles as sample size increases and predictor input systematically evolves to capture more criterion relationships and higher predictor-criterion fidelity. An example is shown in FIGS. 14A-14D.

FIG. 14A shows a first cycle 1402. For example, when an employer first begins
5 to use a system, applicants enter pre-hire application and assessment responses using external data collection devices. The data can be stored and processed as described above, except that as of yet no behavioral predictions appear on the hiring report because a sufficient number of employee histories has not yet been captured by the system.

10 As employee job performance measures are taken, employees leave and complete exit interviews and their managers complete an exit evaluation, or payroll information is collected also using the external data collection devices, employee histories are added to the database. The rate of data accumulation is a function of how quickly people apply, are hired, and then terminate employment. An alternative to
15 capturing post-hire job performance data upon termination is to collect similar data on the same population prior to termination on a concurrent basis. In the example, the size of the validation database is small, there is no adaptive learning, there are no predictive models, and there are no behavioral predictions.

When a sufficient sample of employee histories is available, validation and
20 predictive modeling can occur. Following model development, the second validation cycle 1422 can begin as shown in FIG. 14B. Ineffective pre-hire variables are dropped or replaced with new content and the pre-hire application is modified. Applicant and terminating employee processing continues and more employee histories are added to the database. In the example, the validation database is medium, there is at least one
25 predictive model, and there is at least one behavioral prediction (e.g., length of service or tenure).

A third validation cycle 1442 is shown in FIG. 14C. Initially, predictive modeling might be limited to behavioral criteria commonly observed, such as length of service, rehire eligibility, or job performance ratings because sample sufficiency occurs

first with such common measures. Other less frequently occurring data points (e.g., misconduct terminations) typically accumulate more slowly. As managers begin using the behavioral predictions to select new employees, the composition of the workforce can begin to change (e.g., newer employees demonstrate longer tenure, higher
5 performance, and the like).

As usable samples are obtained for different criteria (e.g., post-hire outcomes), new models are developed to predict these behaviors. Older predictive models can be replaced or re-trained to incorporate both new item content from the item rotation procedure and additional criterion variation resulting from the expanding number of
10 employee histories contained in the validation database. In the example, the validation database is large, there are differentiated models, and a number of behavioral predictions (e.g., tenure, early quit, and eligibility for rehire).

Fourth and subsequent validation cycles 1462 are shown in FIG. 14D. Multiple iterations of the validation cycle using larger and larger validation samples result in
15 multiple complex models trained to produce successively-improving behavioral prediction across the spectrum of measurable job-related outcomes (e.g., eligibility for rehire, tenure, probable job performance, probability of early quit, job fit, misconduct, and the like). In the example, the validation database is very large, there are complex, differentiated models, and many behavioral predictions.

20 The behavioral predictions can become more accurate the longer the system is in place. If used consistently over time, the workforce may eventually be comprised entirely of employees selected on the basis of their similarity to successful former employees. Continued use of the adaptive learning employee selection technology can be expected to produce positive changes in the global metrics used to assess workforce
25 effectiveness. Such metrics include lower rates of employee delinquency (e.g., theft, negligence, absenteeism, job abandonment, and the like), higher rates of productivity (e.g., sales, unit production, service delivery, and the like), longer average tenure and reduced employee turnover, and higher workforce job satisfaction and more effective employee placement.

Example 32 - Exemplary Process Overview

FIG. 15 is a process flow diagram illustrating an exemplary process 1502 for an employment suitability prediction system. At 1512, data is collected. Such collection
5 can be accomplished in a wide variety of ways. For example, electronic data collection units can be distributed, or a URL can be used by employment applicants.

Electronic versions of a standard employment application or tests can be deployed. Also, post-hire data collection can be accomplished by deploying post-hire data collection questionnaires and via payroll data transfer. Also, manager feedback
10 report apparatus (e.g., fax back reports or e-mail report of results) can be deployed so managers can receive information such as hiring recommendations. The service can then be implemented, and data collection can begin.

At 1522, feature selection can take place. Pre-hire application records can be extracted from an applicant processing system, and post-hire outcome data can be
15 extracted from a reports database. Pre- and post- data can be sorted and matched from both sources to create a matched predictor-criterion set. Information theoretic feature selection can be run to identify top-ranking predictive items based on information transmission (e.g., mutual information). Item data characterized by marginal mutual information can be deleted and a distilled predictive modeling dataset can be saved.

20 At 1532, model development can take place. The distilled predictive modeling dataset can be randomized and partitioned into training, testing, and verification subsets. A group of models (e.g., neural networks) that meet performance criteria thresholds can be built by experimenting with multiple neural network paradigms, architectures, and model parameters.

25 The models can be tested for their ability to generalize (e.g., apply learned pattern information from training and test sets to the verification dataset). Non-generalizing models can be discarded and the surviving models can be saved.

Surviving models can be tested for differential prediction, adverse impact and other anomalies. Biased nets can be discarded. Unbiased models can be ranked and saved.

At 1542, model deployment can take place. The top-performing surviving
5 model can be converted to software command code. The code can be integrated into a custom session processing task which executes model processing and exports the output to an imaging program and hiring report generator.

The new session processing task can be tested for appropriate handling and processing of the incoming data stream values in a software test environment. The
10 session processing task code can be refined and debugged if necessary. Then, the new task can be deployed in an operational applicant processing system.

At 1552, performance tuning can take place. Data collection can continue. Sample size can be monitored as incoming data accumulates. When an update threshold is reached, new cases can be added to the matched predictor-criterion set by repeating
15 feature selection 1522. Item content can be revised using a performance driven item rotation procedure (e.g., replace or remove survey items with marginal information transmission). Model development 1532, model deployment 1542, and performance tuning 1552 can then be repeated.

20 **Example 33 - Effectiveness of a Model**

Real-time electronic collection of data and sample size-driven refinement of models can result in high model effectiveness. For example, FIG. 16 shows a graph 16
in which effectiveness 1622 of a reference system is shown. As conditions change over time, the effectiveness 1622 of the system decreases. The mean effectiveness 1624 is
25 also shown.

As system employing real-time electronic data collection and sample size-driven model refinement can exhibit the effectiveness 1632 as shown. As the model is refined, the effectiveness of the model increases over time. Thus, the mean effectiveness 1634 is greater, resulting in a more effective system.

Example 34 - Exemplary Automated Hiring Recommendation Service

Using various of the technologies, a method for providing an automated hiring recommendation service for an employer can be provided. Electronic devices can be stationed at employer sites (e.g., retail outlets). The electronic devices can directly accept pre-hire information from job applicants (e.g., answers to questions from a job application). The pre-hire information can then be sent to a remote site (e.g., via a network of telephone connection) for analysis. An artificial intelligence-based predictive model or other model can be applied to the pre-hire information to generate an automated hiring recommendation, which can be automatically sent to the employer (e.g., via email).

Example 35 - Exemplary Implementation

A behavioral prediction model can be developed to generate an estimate of the tenure (length of service in days) to be expected of applicants for employment as customer service representatives of a national chain of video rental stores. Such predictions can be based on the characteristics and behaviors of past employees in the same job at the same company. Application of the model can result in higher average tenure and lower employee turnover.

As a specific example, pre-hire application data used to develop this exemplary model was collected over a period of a year and a half using an electronic employment application as administered using screen phones deployed in over 1800 stores across the United States. Termination records of employees hired via the system were received by download. Over 36,000 employment applications were received in the reporting period, of which approximately 6,000 resulted in employment. Complete hire to termination records were available for 2084 of these employees, and these records were used to develop the model.

When building the model, definition of system inputs and outputs was accomplished. Independent or predictor variables can be measures of individual

characteristics thought to be related to a behavior or outcome resulting from a behavior. In industrial psychology and employee selection, typical predictor variables might be measures of education, experience or performance on a job-related test. Criterion variables can be measures of the behavior or outcome to be predicted and might include sales effectiveness, job abandonment, job performance as measured by supervisor ratings, employee delinquency and other behavioral metrics or categories.

In this example, predictor variables are inputs and criterion variables are outputs. In this research, input variables consist of a subset of the employment application data entered by applicants when applying for jobs (see Tables 4 and 5 for a listing of the variables used in this model). The output or criterion is the number of days that an employee stayed on the payroll.

The process of identifying the subset of predictor variables to be used in a model is sometimes called “feature selection.” While any information gathered during the employment application process may have predictive value, the set of predictors is desirably reduced as much as possible. The complexity (as measured by the number of network connections) of a network can increase geometrically with the number of inputs. As complexity increases so can training time along with the network's susceptibility to over-training. Therefore inputs with less predictive power can be eliminated in favor of a less complex neural network model.

For the tenure prediction model in this illustrative example, information theoretic methods were employed to determine the subset of input variables that maximized information transmission between the predictor set and the criterion. Such an approach can rely on the statistical theory of independent events, where events p_1, p_2, \dots, p_n are considered *statistically independent* if and only if the probability P , that they occur on a given trial is

$$P = \prod_{i=1}^n p_i \quad (1)$$

Conversely, the measurement of how much a joint distribution of probabilities differs from the independence distribution can be used as a measure of the statistical dependence of the random events.

Information theoretic entropy can provide a convenient metric for estimating the
 5 difference between distributions. The entropy, $H(X)$ (measured in bits) of the distribution of a discrete random variable X with n states can be

$$H(X) = -\sum_{i=1}^n p_i \log_2 p_i \quad (2)$$

where p_i is the probability of state i . Entropy can be maximized when a distribution is uniform. For example, FIG. 17 shows a graph 1702 of the entropies 1722 of a single
 10 variable, discrete 2-state distributions and how their probabilities vary.

Similarly, for a multivariate distribution constrained by specified marginal distributions, the distribution that maximizes entropy can be the independence distribution. Therefore, given a joint distribution with fixed marginals, the distribution that minimizes entropy can be the distribution for which the variables are completely
 15 dependent. Dependence can be viewed as constraint between variables and as constraint is reduced, entropy increases. Information theoretic analysis of a distribution is then the measurement of constraint. Decreasing entropy can indicate dependence (minimal entropy, maximum constraint), and increasing entropy can indicate independence (maximum entropy, minimum constraint). Assuming some constraint between
 20 variables, sampled distribution can lie somewhere between complete dependence and independence and have a measurable entropy.

If we are analyzing the joint distribution of the variables X and Y , the entropy for this sampled distribution can be $H(XY)$. The entropies of the variables X and Y measured separately are $H(X)$ and $H(Y)$ and can be computed using the marginals
 25 of the joint distribution.

Since $H(X)$ and $H(Y)$ are calculated from the marginals and entropy can be logarithmic,

$$H(X) + H(Y) = H(XY) \quad (3)$$

if there is no constraint between X and Y .

5 Or:

$$H(XY) = H(X) + H(Y) \quad (4)$$

if and only if X and Y are independent.

This equality can indicate that there is no relationship between X and Y and the joint distribution of the variables is the independence distribution.

10 Information transmission T can be the measure of the distance between distributions along the continuum described above. For discrete random variables X and Y , $T(X : Y)$ the information transmission between X and Y , is computed:

$$T(X : Y) = H(X) + H(Y) - H(XY) \quad (5)$$

$T(X : Y)$ is the difference between the entropies of the independence distribution and the sampled joint distribution. The degree of dependence between X and Y can therefore be computed by measuring information transmission. A small value for $T(X : Y)$ indicates the variables X and Y are nearly independent, whereas a large value suggests a high degree of interaction.

20 In a directed system, such as a predictive model, the measure of information transmission between the distribution of an independent variable X and a dependent variable Y can be used to gauge the predictive value of X . The goal can be to find a subset S of the independent variables V such that, for the set of dependent variables D :

$$T(D : V) \approx T(D : S) \quad (6)$$

However, as discussed, the modeling technique to be employed may limit the cardinality of S so the filtering process can be guided by the following considerations:

- 25 1. if S' is any subset of V smaller than S , then $T(D : S')$ is significantly smaller than $T(D : S)$.

2. if S' is any subset of V larger than S , then $T(D : S')$ is not significantly larger than $T(D : S)$

Since information theoretic transmission can measure the degree of difference between distributions of variables, without regard to the nature of the difference, the technique
5 can be considered “model free”. This property allows the methodology to work as an effective filter regardless of the subsequent modeling techniques employed.

When this type of feature selection was applied to tenure prediction, 56 questions (see Tables 4 and 5) were selected as having the most predictive value with respect to applicant tenure.

10 Once the set of predictor variables or inputs has been defined and the output criterion variable specified, a neural network model can be trained. For the tenure prediction model, 2084 cases were available. This sample was divided into training, test and verification sets. The training set contained 1784 cases and the verification and test sets contained 150 cases each.

15 The best performing neural network architecture was found to be a single hidden layer feed-forward network with 56 input nodes and 40 hidden layer nodes.

The network was developed with the STATISTICA Neural Network package using a combination of quick-propagation and conjugate gradient training.

The performance on the training and verification sets began to diverge
20 significantly after 300 epochs. This was deemed to be the point of over-training. Optimal performance on the hold-out sets was achieved at 100 epochs. The results are shown in Table 3, which contains final distribution statistics of model output for each of the three data subsets. Unadjusted correlation and significance statistics are in relation to actual tenure. By any standard, an employee selection procedure with a correlation in
25 the .5 range with a job-related criteria is not merely acceptable, but exceptional. Many validated selection procedures in use today were implemented on the basis of validity coefficients in the range of .2 to .3.

Table 3 – Summary Statistics of Model Output

	Train	Verify	Test
Data Mean	73.42657	82.89333	71.03333
Data S.D.	70.92945	71.22581	62.16501
Error Mean	-0.4771	-7.2582	7.440303
Error S.D.	60.84374	60.93211	53.80157
Correlation	0.514349	0.51901	0.503975
Significance	0.000	0.000	0.000

Based on the correlation between prediction and the hold-out sets, the expected correlation between predictive model output and actual tenure for future applicants should be in the range of 0.5.

As described in the example, information theoretic feature selection was used to identify fifty-six biodata and personality assessment item responses that were related to employee tenure in a sample of over two thousand employees at a national video rental chain. The data was collected via interactive electronic survey administration on a network of screen phones deployed in many regions of the U.S.

A fully-connected, feed-forward backpropagation neural network was trained to produce an estimate of tenure in days using these fifty-six predictor variables (e.g., answers to the questions) as inputs. Network architecture consisted of 56 input neurons or nodes, a hidden layer of forty nodes and one output node. Conjugate gradient descent training resulted in convergence between training and test set minimum error in about 300 iterative training exposures to the data. Model performance on an independent hold-out sample obtained a statistically significant correlation of .5 with actual tenure. These results are well within the range of acceptable performance for a criterion-referenced employee selection procedure and represent a significant improvement over many systems.

In the example, based on information theoretic analysis, the responses to the questions shown in Tables 4 and 5 were deemed to be the most predictive. The

following descriptions are the questions in their entirety accompanied by the possible responses.

To determine that these questions were the most predictive, information theoretic analysis of the joint distribution of the response (alone or together with other responses) and the dependent variable, tenure, was performed. The nature of the relationship between a specific response and the Criterion variables may not be known, however the predictive success of the neural model suggests this relationship has, to some degree, been encoded in the weight matrix of the neural network.

10

Table 4 – Pre-hire Content Examples

<ol style="list-style-type: none"> 1. How long do you plan to stay with this job if hired? <ol style="list-style-type: none"> 1 - Less than 6 months 2 - 6-12 months 3 - More than 1 year 2. Have you ever worked for this employer before? <ol style="list-style-type: none"> 1 - Yes 2 - No 3. Reason for leaving? (if previously employed by this employer) 4. Which type of position do you desire? <ol style="list-style-type: none"> 1 - Store Director 2 - Assistant Director 3 - Customer Service Representative 4 - Shift Leader 5 - Let's Discuss 5. What do you expect to earn on an hourly basis? (hourly wage given) 6. Desired Schedule? <ol style="list-style-type: none"> 1 - Regular (not seasonal) 2 - Seasonal 7. Desired Hours? <ol style="list-style-type: none"> 1 - Full time 2 - Part time 8. When would you be available to start? <ol style="list-style-type: none"> 1 - Right Away (within the next day) 2 - Specific Date (if not available to start within the next day) 9. Highest Education Level? <ol style="list-style-type: none"> 1 - 2 Years of College or Less: <ol style="list-style-type: none"> 1 - Not indicated 2 - Less than HS Graduate

- 3 - HS graduate or equivalent
- 4 - Some college
- 5 - Technical School
- 6 - 2-year college degree
- 2 - More than 2 years of college
 - 1 - Bachelor's level degree
 - 2 - Some graduate school
 - 3 - Master's level degree
 - 4 - Doctorate (academic)
 - 5 - Doctorate (professional)
 - 6 - Post-doctorate
 - 7 - Degree not completed
 - 8 - 2-year college degree
- 10. What was your reason for leaving? (last job)
 - 1 - Voluntarily quit
 - 2 - Involuntarily terminated
 - 3 - Laid off
 - 4 - Still there
- 11. What was/is your job title? (last job)
 - 1 - Cashier
 - 2 - Stock person
 - 3 - Customer Service Representative
 - 4 - Management
 - 5 - Other
- 12. Please describe the area you worked in. (last job)
 - 1 - Apparel
 - 2 - Inventory
 - 3 - Customer service
 - 4 - Food service
 - 5 - Operations
 - 6 - Computers/Electronics
 - 7 - Merchandising
 - 8 - Personnel
 - 9 - Other
- 13. What was/is you supervisor's last name?
(given or not given)
- 14. May we contact this employer?
 - 1 - Yes
 - 2 - No
- 15. What was your reason for leaving? (prior job)
 - 1 - Voluntarily quit
 - 2 - Involuntarily terminated
 - 3 - Laid off

- 4 - Still there
- 16. What was/is your job title? (prior job)
 - 1 - Cashier
 - 2 - Stock person
 - 3 - Customer Service Representative
 - 4 - Management
 - 5 - Other
- 17. Please describe the area you worked in. (prior job)
 - 1 - Apparel
 - 2 - Inventory
 - 3 - Customer service
 - 4 - Food service
 - 5 - Operations
 - 6 - Computers/Electronics
 - 7 - Merchandising
 - 8 - Personnel
 - 9 - Other
- 18. What was/is you supervisor's last name? (prior job)
(given or not given)
- 19. May we contact this employer? (prior job)
 - 1 - Yes
 - 2 - No
- 20. What was your reason for leaving? (prior to prior job)
 - 1 - Voluntarily quit
 - 2 - Involuntarily terminated
 - 3 - Laid off
 - 4 - Still there
- 21. What was/is your job title? (prior to prior job)
 - 1 - Cashier
 - 2 - Stock person
 - 3 - Customer Service Representative
 - 4 - Management
 - 5 - Other
- 22. Please describe the area you worked in. (prior to prior job)
 - 1 - Apparel
 - 2 - Inventory
 - 3 - Customer service
 - 4 - Food service
 - 5 - Operations
 - 6 - Computers/Electronics
 - 7 - Merchandising
 - 8 - Personnel
 - 9 - Other

23. What was/is you supervisor's last name? (prior to prior job)
(given or not given)
24. May we contact this employer? (prior to prior job)
1 - Yes
2 - No
25. Academic Recognitions?
(listed or not listed)
26. Other Recognitions?
(listed or not listed)
27. Have you previously applied for employment at this employer?
1 - Yes
2 - No
28. Referral Source
- 1 - Referred to this employer by Individual or Company
 - 1 - Agency
 - 2 - Client Referral
 - 3 - College Recruiting
 - 4 - Employee Referral
 - 5 - Former Employee
 - 6 - Executive Referral
 - 7 - Executive Search
 - 2 - Other Source of Referral
 - 1 - Advertisement
 - 2 - Job Fair
 - 3 - Job Posting
 - 4 - Open House
 - 5 - Other Source
 - 6 - Phone Inquiry
 - 7 - Unknown
 - 8 - Unsolicited
 - 9 - Walk In
29. Last name of referral
(listed or not listed)
30. Any other commitments?
(listed or not listed)
31. Any personal commitments?
(listed or not listed)

The possible responses to the question of Table 5 are as follows: "1 - It is definitely false or I strongly disagree, 2 - It is false or I disagree, 3 - It is true or I agree, 4 - It is definitely true or I strongly agree."

Table 5 – Pre-hire Content Examples (e.g., Hourly Workers)

1. You have confidence in yourself.
2. You are always cheerful.
3. You get mad at yourself when you make mistakes.
4. You would rather work on a team than by yourself.
5. You try to sense what others are thinking and feeling.
6. You can wait patiently for a long time.
7. When someone treats you badly, you ignore it.
8. It is easy for you to feel what others are feeling.
9. You keep calm when under stress.
10. You like to be alone.
11. You like to talk a lot.
12. You don't care what people think of you.
13. You love to listen to people talk about themselves.
14. You always try not to hurt people's feelings.
15. There are some people you really can't stand.
16. People who talk all the time are annoying.
17. You are unsure of yourself with new people
18. Slow people make you impatient.
19. Other people's feelings are their own business.
20. You change from feeling happy to sad without any reason.
21. You criticize people when they deserve it.
22. You ignore people you don't like.
23. You have no big worries.
24. When people make mistakes, you correct them.
25. You could not deal with difficult people all day.

Example 36 - Exemplary Implementation Using

5

Information-Theoretic Feature Selection

Information-theoretic feature selection can be used to choose appropriate inputs for a model. In the following example, the source for the data used to develop the model was a large national video rental company. The sample contains over 2000 cases, with 160 responses to application questions collected prior to hiring and tenure (in days)

10 for former employees. The model was constructed to predict the length of employment for a given applicant, if hired.

The application itself consists of 77 bio-data questions (e.g., general, work related, information, job history, education and referrals questions) and 83 psychometric questions. The psychometric assessment portion was designed to predict the reliability of an applicant in an hourly, customer service position. For the purposes of model development, each question response was treated as a single feature and the reliability score was not provided to the neural network or feature selection process.

While any information gathered during the application process may have predictive value, the set of input variables (independent variables or “IVs”) can be reduced.

Possible justifications are as follows:

1. Not all potential IVs may have significant predictive value. The use of variables with little or no predictive value as inputs can add noise. Adding IVs to the model which cannot improve predictive capability may degrade prediction since the network may need to adapt to filter these inputs. This can result in additional training time and neural resources.

2. Predictive models can provide a mapping from an input space to an output space. The dimensionality of this input space increases with the number of inputs. Thus, there are more parameters required to cover the mapping which in turn increases the variance of the model (in terms of the bias/variance dilemma); such a problem is sometimes referred to as the “curse of dimensionality.”

IVs with less predictive power can be eliminated in favor of a less complex neural network model by applying feature selection. Such methods fall into two general categories: filters and wrappers, either of which can be used.

1. Wrappers can use the relationship between model performance and IVs directly by iteratively experimenting with IV subsets. Since the nature of the bias of the feature selection method matches that of the modeling technique, this approach can be theoretically optimal if the search is exhaustive.

The exhaustive application of wrappers can be computationally overwhelming for most modeling problems since the number of possible subsets is

$$\binom{n}{k} = \frac{n!}{k!(n-k)!} \tag{7}$$

where n is the total number of IVs and k is the cardinality of the subset of features.

5 Additionally, there can be non-determinism within the modeling process. In neural modeling, though training algorithms are typically deterministic, random initialization of the weight parameters varies the results of models developed with the same inputs. Therefore, even exhaustive trials may not prove conclusive with respect to estimating the predictive value of a set of features.

2. Filters can analyze the relationship between sets of IVs and dependent variables (DVs) using methods independent of those used to develop the model.

10 The bias of the filter may be incompatible with that of the modeling technique. For example, a filter may fail to detect certain classes of constraint, which the subsequent modeling stage may utilize. Conversely, the filter may identify relations which cannot be successfully modeled. Ideally, a filter can be completely inclusive in that no constraint which might be replicated by the subsequent modeling stage would be
15 discarded.

Information-theoretic feature selection can make use of the statistical theory of independent events. Events p_1, p_2, \dots, p_n are considered statistically independent if and only if the probability P , that they all occur on a given trial is

$$P = \prod_{i=1}^n p_i \tag{8}$$

20 The degree to which a joint distribution of probabilities diverges from the independence distribution may be used as a measure of the statistical *dependence* of the events.

Information-theoretic entropy can provide a convenient metric for quantifying the difference between distributions. The entropy, $H(X)$ (measured in bits), of the
25 distribution of a discrete random variable, X , with n states can be

$$H(X) = -\sum_{i=1}^n p_i \log_2 p_i \tag{9}$$

where p_i is the probability state i .

Entropy can be maximized when a distribution is most uncertain. If a distribution is discrete, this occurs when it is uniform. FIG. 17 shows a graph of the entropies of a single variable, 2-state distribution as the state probabilities vary.

5 For a multivariate distribution constrained by fixed marginals, the distribution which maximizes entropy can be the independence distribution (calculated as the product of the marginals). The distribution which minimizes entropy can be the distribution for which the variables are completely dependent.

Dependence can be constraint between variables, so as constraint is reduced,
 10 entropy increases. Information-theoretic analysis can therefore be used to measure constraint. For a joint distribution of discrete variables, X and Y , the total entropy, $H(XY)$ can be

$$H(XY) = -\sum_{i,j} p_{ij} \log_2 p_{ij} \quad (10)$$

where p_{ij} is the probability of state i, j occurring in the joint distribution of X and Y ,
 15 where i designates the state of X and j is the state of Y . The entropies of X and Y are computed with the marginals of the joint distribution

$$H(X) = -\sum_i \left(\sum_j p_{ij} \right) \log_2 \left(\sum_j p_{ij} \right) \quad (11)$$

$$H(Y) = -\sum_j \left(\sum_i p_{ij} \right) \log_2 \left(\sum_i p_{ij} \right) \quad (12)$$

Information transmission (or “mutual information”) can be the measure of the distance
 20 between the independence and observed distributions along the continuum discussed above. For X and Y , $T(X:Y)$ (the information transmission between X and Y), is computed

$$T(X:Y) = H(X) + H(Y) - H(XY) \quad (13)$$

25

In a directed system, the measure of information transmission between the distribution

of an independent variable X and a dependent variable Y is a gauge of the predictive value of X . $H(X) + H(Y) = H(XY)$ if and only if there is no constraint between X and Y , in which case X would be a poor predictor for Y .

In order for a computed transmission value, T , to be considered an accurate
 5 measure of existing constraint, the statistical significance of T for some confidence level, α , can be determined using the χ^2 test. The degrees of freedom (df) for a transmission, $T(X:Y)$, can be calculated

$$df_{T(X:Y)} = df_{XY} - df_X - df_Y \tag{14}$$

As the size of the joint distribution increases, so does the df for the significance
 10 of the transmission value. Since χ^2 significance decreases as df increases, the data requirements for transmissions containing a large number of variables can quickly become overwhelming.

A superior feature set can be determined. A goal can be to discover a subset S of the independent variables V that has the same predictive power as the entire set with
 15 respect to the dependent variables, D .

$$T(V : D) \approx T(S : D) \tag{15}$$

The filtering process can therefore be guided by the following:

1. if S' is any subset of V smaller than S , then $T(S':D)$ is significantly smaller than $T(S:D)$.
- 20 2. if S' is any subset of V larger than S , then $T(S':D)$ is not significantly larger than $T(S:D)$.

Higher-order interactions are synergies between variables where the predictive power of a set of variables is significantly higher than that of the sum of the individual variables. In terms of information transmission for the IVs X_1, \dots, X_n , and dependent
 25 variable D , this is represented,

$$T(X_1:D) + \dots + T(X_n:D) < T(X_1, \dots, X_n:D) \tag{16}$$

An illustration of this phenomenon among discrete binary variables: A, B and C, is shown by the contingency table in Tables 6A and 6B.

Table 6A – Contingency Table for Distribution ABC, C=0

	B=0	B=1
A=0	1/4	0
A=1	0	1/4

5

Table 6B – Contingency Table for Distribution ABC, C=1

	B=0	B=1
A=0	0	1/4
A=1	1/4	0

For the illustrated system, the following transmissions are computed:

$$T(A:C) = H(A) + H(C) - H(AC) = 0 \text{ bits}$$

$$T(B:C) = H(B) + H(C) - H(BC) = 0 \text{ bits}$$

10 $T(AB:C) = H(AB) + H(C) - H(ABC) = 1 \text{ bit}$

Knowledge of *A* or *B* individually does not reduce the uncertainty of *C*, but knowledge of *A* and *B* eliminates uncertainty since only one state of *C* is possible. With only first order transmissions values, *A* and *B* would not appear to be predictive features, when in fact, together they are ideal.

15

Higher order interactions were observed in the video clerk tenure data. Table 7 lists the top ten single variable transmissions between the psychometric questions and tenure. Table 8 shows the top five, two and three variable transmissions. Each of the most predictive sets of questions (based on transmission values) in both the second and third order lists, T(q35 q73:tenure) and T(q4 q12 q39:tenure), contain only one question from the top ten most predictive questions based on first order transmissions.

20

Table 7 –Single Order Transmissions Between Psychometrics and Tenure

variables	trans.	%H(DV)	<i>df</i>	χ^2 sig.
T(q83:tenure)	0.0168	0.754	27	0.999
T(q3:tenure)	0.0140	0.628	27	0.991
T(q63:tenure)	0.0135	0.607	27	0.987
T(q65:tenure)	0.0133	0.598	27	0.985
T(q48:tenure)	0.0133	0.595	27	0.984
T(q44:tenure)	0.0132	0.593	27	0.984
T(q35:tenure)	0.0128	0.573	27	0.977
T(q21:tenure)	0.0127	0.569	27	0.975
T(q8:tenure)	0.0123	0.553	27	0.967
T(q69:tenure)	0.0123	0.552	27	0.966

Table 8 – Higher (second and third) Order Transmissions between Psychometrics and Tenure

variables	trans.	%H(DV)	<i>df</i>	χ^2 sig.
T(q35 q73:tenure)	0.0593	2.663	135	1.00
T(q21 q83:tenure)	0.0588	2.639	135	1.00
T(q39 q65:tenure)	0.0585	2.627	135	1.00
T(q61 q70:tenure)	0.0569	2.553	135	0.999
T(q44 q53:tenure)	0.0567	2.546	135	0.999
T(q4 q12 q39:tenure)	0.1808	8.112	567	0.921
T(q10 q39 q65:tenure)	0.1753	7.864	567	0.811
T(q4 q39 q44:tenure)	0.1720	7.718	567	0.712
T(q4 q39 q51:tenure)	0.1718	7.709	567	0.705
T(q52 q61 q70:tenure)	0.1717	7.702	567	0.700

5

Such interactions can complicate the search for the optimal set S since the

members of V may not appear as powerful predictors in calculated transmissions using sets of features of cardinality less than $|S|$ (the cardinality of the optimal subset S).

Due to issues of χ^2 significance, it is frequently overwhelming to calculate significant transmission values for sets of variables of cardinality approaching $|S|$.

5 Additionally, since the number of subsets of a given cardinality soon become very large, even if the significance issues were addressed, computational limitations would persist.

In feature selection algorithms that approximate an exhaustive search for S by computing only pairwise transmissions, higher-order interaction effects are not detected. Such methods may not accurately approximate S since only variables which are strong
10 single variable predictors will be selected.

Based on the following guidelines, heuristics were applied in an effort to address the problems of combinatorics and significance in measuring higher-order relations.

Although it is possible for members of the optimal subset of IVs, S , to be completely absent from all large lower order transmissions, this is probably unlikely. An
15 omission can be increasingly unlikely as the order of the transmissions calculated approaches $|S|$. It is therefore likely that significant members of S will appear in the top n transmissions of the highest order transmission computed, where n is sufficiently large. Thus, as $n \rightarrow |S|$, the union of the set of IVs appearing in the most predictive transmissions will probably approach S .

20 With these guidelines, a process for generating an approximation to S (S') given the set V of significant IVs and the set D of all DVs, can be presented.

In the following process (1-6), T_k will be used to denote the set of transmissions of order k (containing k IVs) from a set of n features.

1. Calculate the transmissions, T_k for the highest order, k , for which the $\binom{n}{k}$
25 transmissions may be calculated.

2. Choose the m unique transmissions of the greatest magnitude from T_k to be the base set for higher-order transmissions.

3. Generate T'_{k+1} by adding the IV to numbers of T_k which generates the set T_{k+1}

with the largest transmission values. Note that T'_{k+1} is a subset of T_{k+1} since it contains only those members of T_{k+1} which can be generated from T_k by adding one independent variable to each transmission.

4. Discard any duplicate transmissions.
5. Repeat Steps 3 and 4 until χ^2 significance is exhausted.
6. Take the union of the variables appearing in as many of the most predictive transmissions as is necessary to generate a set of size $|S|$. This union is S' , the approximation of the set S .

Since $|S|$ is unknown, this value is estimated. However, $0 \leq |S| \leq |V|$, so it is often feasible to experiment with the S' for each cardinality.

An issue raised by feature selection processes is the effect of dependence between members of S' . This dependence may be viewed as the redundancy in the predictive content of the variables. One solution proposed is to calculate the pairwise transmissions $T(s'_i: s'_j)$, between features s'_i and s'_j , from a candidate S' . Features which exhibit high dependence (high pairwise transmissions) are penalized with respect to the likelihood of their inclusion in the final S' .

Dependence between features is dealt with implicitly in the process above since such dependence will reduce the entropy, thereby reducing the magnitude of the transmission between a set of features and the set of dependent variables. Highly redundant feature sets will have low transmission values relative to less redundant sets of the same cardinality and will therefore be less likely to contribute to S' .

While tenure in days is a discrete measure, the number of possible states makes it difficult to use the variable without transformation since a large number of states makes the joint distribution sparse (high df relative to the data population) and any transmissions calculated statistically insignificant. Since tenure is an ordered variable, applying a clustering algorithm was not problematic.

Clustering is a form of compression, so care can be taken to minimize information loss. The clustering phase was guided by efforts to maximize the entropy of the clustered variable within the confines of the needs of statistical significance.

Though transmission values did vary across clustering algorithms and granularity, the results in terms of S' were consistent.

Transmissions were calculated by combining cluster analysis and information-theoretic analysis. For the video clerk data set (containing 160 IVs) it was decided that the cardinality of the sets of IVs for which transmissions could be calculated was 4. From there, two additional orders of cardinality were calculated by supplementing the 4th order transmissions (as described in step 3 of the process). The union of independent variables appearing in the largest transmissions was taken to be S' . Experimentation with neural models using S' of different cardinalities yielded the best results when $|S'| =$
10 56.

An interesting aspect of the application questions chosen by the feature selection method was the mix of bio-data and psychometrics. Of the 56 features used as inputs for the most successful model, 31 came from the bio-data section of the application and 25 came from the psychological assessment. Of particular interest was the “coupling” of certain bio-data and assessment questions. Such pairs would appear together throughout the analysis of transmission over a range of cardinalities. (e.g., they would appear as a highly predictive pair and would subsequently appear together in higher-order sets of IVs).
15

The synergistic effect between the two classes of question became apparent when models were generated using exclusively one class or the other (using only psychometrics or only bio-data questions). With comparable numbers of inputs, these models performed significantly worse than their more diverse counterparts. These results are particularly interesting since psychological assessments typically do not include responses from such diverse classes of questions.
20

In the example, the most successful neural model developed was a single hidden layer, feed-forward neural network with 56 inputs ($|S'| = 56$), slid 40 hidden nodes. The network was trained using the conjugate gradient method. Of the total data set size of 2084, 1784 were allocated to the training set and 300 were “hold-out”.
25

The performance measures of behavioral prediction models can be measured

using the correlation coefficient. For the neural model described, the correlation between prediction and actual tenure for the hold-out sample was $p = 0.51$. For comparison, a number of other models were generated using either no feature selection or alternate feature selection methods. These models used the same network
5 architecture and training algorithm. The best model generated using the entire data set (e.g., all features), was a 160-90-1 configuration (160 inputs and 90 hidden layer nodes) which achieved a maximum hold-out correlation of $p = 0.44$. Alternate feature selection algorithms: genetic algorithms, and forward and reverse stepwise regression, using the same number of features (56), failed to achieve a hold-out correlation better than $p =$
10 0.47.

Information-theoretic feature selection is a viable and accurate method of identifying predictors of job performance in employee selection. The capacity to identify non-linear and higher-order interactions ignored by other feature selection methods represents a significant technique in constructing predictive models.

15

Alternatives

It should be understood that the programs, processes, or methods described herein are not related or limited to any particular type of computer apparatus, unless indicated otherwise. Various types of general purpose or specialized computer
20 apparatus may be used with or perform operations in accordance with the teachings described herein. Elements of the illustrated embodiment shown in software may be implemented in hardware and vice versa. In view of the many possible embodiments to which the principles of our invention may be applied, it should be recognized that the detailed embodiments are illustrative only and should not be taken as limiting the scope
25 of our invention. Rather, we claim as our invention all such embodiments as may come within the scope and spirit of the following claims and equivalents thereto.

CLAIMS

We Claim:

1. An apparatus for assisting in determining the suitability of an individual for employment by an employer, the apparatus comprising:
 - 5 an electronic data interrogator operable to present a first set of a plurality of questions to the individual;
 - an electronic answer capturer operable to electronically store the individual's responses to at least a selected plurality of the first set of questions presented to the individual;
 - 10 an electronic predictor responsive to the stored answers and operable to predict at least one post-hire outcome if the individual were to be employed by the employer, the predictor providing a prediction of the outcome based upon correlations of the stored answers with answers to sets of questions by other individuals for which post-hire information has been collected; and
 - 15 an electronic results provider providing an output indicative of the outcome to assist in determining the suitability of the individual for employment by the employer.
2. An apparatus according to claim 1 wherein the post-hire outcome indicates whether the individual is predicted to be eligible for re-hire after termination.
- 20 3. An apparatus according to claim 1 wherein the post-hire outcome indicates whether the individual is predicted to be involuntarily terminated.
4. An apparatus according to claim 1 wherein the post-hire outcomes indicate whether the individual is predicted to be involuntarily terminated and whether the individual is predicted to be eligible for re-hire after termination.
- 25

5. An apparatus according to claim 1 wherein at least one of the predicted outcomes is a predicted probability that a particular outcome value range will be observed.
- 5 6. An apparatus according to claim 1 wherein at least one of the predicted outcomes is a predicted value for a continuous variable.
7. An apparatus according to claim 1 wherein the predicted outcome is a predicted range of values for a continuous variable.
- 10 8. An apparatus according to claim 1 wherein the predicted outcome indicates whether the individual will belong to a particular group.
9. An apparatus according to claim 1 wherein at least one of the predicted outcomes is a predicted ranking of the individual for the outcome.
- 15 10. An apparatus according to claim 1 wherein at least one of the predicted outcomes indicates a predicted employment tenure for the individual.
- 20 11. An apparatus according to claim 1 wherein at least one of the predicted outcomes indicates a predicted number of accidents for the individual.
12. An apparatus according to claim 1 wherein at least one of the predicted outcomes indicates a predicted sales level for the individual.
- 25 13. An apparatus according to claim 1 wherein the predictor comprises an artificial intelligence-based prediction system.

14. An apparatus according to claim 1 wherein the data interrogator is located at a first location and the predictor is located at a second location which is remote from the first location.

5 15. An apparatus according to claim 14 wherein the data interrogator and the predictor are selectively electronically interconnected through a network.

16. An apparatus according to claim 15 wherein the network is the worldwide web.

10

17. An apparatus according to claim 15 wherein the network is a telephone network.

15 18. An apparatus according to claim 15 wherein the network is a satellite network.

19. An apparatus according to claim 1 wherein the first set of questions may be varied.

20 20. An apparatus according to claim 19 wherein the predictor is operable to determine and indicate a lack of a correlation between one or more questions of the first set of questions and at least one of the predicted outcomes, whereby questions which lack the correlation may be discarded or modified.

25 21. An apparatus according to claim 1 wherein at least one of the predicted outcomes is longevity with an employer and the answers to sets of questions by other individuals comprise answers by employees of the employer for whom longevity has been determined.

22. An apparatus according to claim 1 in which the predictor comprises at least one model which provides a predictor of the probability of the individual exhibiting at least one of the predicted outcomes, the model being based on correlations between the at least one of the predicted outcomes and the answers to questions by the other individuals, including answers by at least some employees of the employer, the model taking at least selected answers of the stored answers as inputs to the model, a probability of the individual exhibiting the at least one of the predicted outcomes being provided as an output of the model.

23. An apparatus according to claim 22 wherein the model comprises at least one neural network.

24. An apparatus according to claim 1 wherein the predictor is responsive to the stored answers and operable to predict plural outcomes if the individual were to be employed by the employer.

25. A method for assessing suitability of persons for employment based on information for hired employees, the method comprising:

- collecting pre-hire applicant information for hired employees before they are hired;
- collecting post-hire measures of the job effectiveness of hired employees;
- constructing an artificial intelligence model identifying associations of patterns within the pre-hire data associated with patterns of job effectiveness in the post-hire data;
- collecting pre-hire information for a new applicant; and
- applying the artificial intelligence model to the pre-hire information for the new applicant to provide a prediction of the new applicant's suitability for employment.

26. The method of claim 25 further comprising:

collecting post-hire information for the new applicant; and
using at least the pre-hire and post-hire information for the new applicant to
refine the artificial intelligence model.

5 27. The method of claim 25 further comprising:
 constructing at least one other artificial intelligence model of a different type;
 and
 assessing the relative effectiveness of the artificial intelligence models at
 predicting suitability of employees for employment based on actual employment
10 effectiveness of employees hired based on the models.

 28. An apparatus for assisting in determining the suitability of an individual
 for employment by an employer, the apparatus comprising:
 means for electronically presenting a first set of a plurality of questions to the
15 individual;
 means for electronically storing the individual's responses to at least a selected
 plurality of the first set of questions presented to the individual;
 responsive to the stored answers, means for predicting at least one post-hire
 outcome if the individual were to be employed by the employer, the means for
20 predicting providing a prediction of the outcome based upon correlations of the at least
 one characteristic with answers to sets of questions by other individuals and the
 closeness of the stored answers to such correlations; and
 means for providing an output indicative of the outcome to assist in determining
 the suitability of the individual for employment by the employer.

25

29. An artificial intelligence-based system for predicting employee behaviors based on pre-hire information collected for the employee, the system comprising:

an electronic device for presenting an employment application comprising a set of questions to an employment candidate, wherein the electronic device is operable to
5 transmit answers of the employment candidate to a central store of employee information, wherein the central store of employee information comprises information collected for a plurality of candidate employees and a plurality of hired employees;

an artificial intelligence-based model constructed from information collected from the hired employees based on answers provided by the hired employees and
10 employment behaviors observed for the hired employees;

a software system for supplying the answers of the employment candidate to the artificial intelligence-based model to produce predicted employment behaviors for the employment candidate; and

a report generator to produce a hiring recommendation report for the
15 employment candidate based on the predicted employment behaviors of the employment candidate.

30. A computer-implemented method of predicting employment performance characteristics for a candidate employee based on pre-hire information
20 collected for hired employees, the method comprising:

collecting data indicating pre-hire information for a plurality of the hired employees;

collecting data indicating post-hire outcomes for the hired employees;

constructing an artificial intelligence-based model from the pre-hire information
25 and the post-hire outcomes for the employees;

from the candidate employee, electronically collecting data indicating pre-hire information of the candidate employee; and

applying the model to the collected pre-hire information of the candidate employee to generate one or more predicted post-hire outcomes for the candidate employee.

5 31. The method of claim 30 wherein collecting data from the candidate employee comprises electronically presenting a set of questions at an electronic device and electronically collecting answers to the questions at the electronic device.

 32. The method of claim 30 wherein the pre-hire information comprises one
10 or more pre-hire characteristics and constructing the model comprises:
 identifying one or more pre-hire characteristics as ineffective predictors; and
 responsive to identifying the pre-hire characteristics as ineffective predictors,
omitting the ineffective predictors from the model.

15 33. The method of claim 30 further comprising:
 providing a report indicating applicant flow.

 34. The method of claim 30 wherein constructing the model comprises:
 constructing a plurality of proposed models, wherein at least two of the models
20 are of different types; and
 selecting a superior proposed model as the model to be used.

 35. The method of claim 34 wherein at least two of the proposed models are
different neural network types.

25 36. The method of claim 35 wherein the two proposed models are both feed-
forward neural networks.

37. The method of claim 35 wherein the two proposed models are chosen from the following:

back propagation, conjugate gradients, quasi-Newton, Levenberg-Marquardt, quick propagation, delta-bar-delta, linear, radial basis function, and generalized
5 regression network.

38. The method of claim 30 wherein at least one of the predicted post-hire outcomes is denoted as a probability that a particular value range of a job effective measure will be observed for a candidate employee.

10

39. The method of claim 30 wherein at least one of the predicted post-hire outcomes is denoted as a value for a continuous variable.

40. The method of claim 30 wherein at least one of the predicted post-hire
15 outcomes is denoted as a relative ranking for an outcome.

41. The method of claim 40 wherein the ranking is relative to other employment candidates.

20 42. The method of claim 40 wherein the ranking is relative to the hired employees.

43. The method of claim 30 further comprising:
storing a relative importance of one or more particular post-hire outcomes; and
25 generating automated hiring recommendations based on the predicted post-hire outcomes for the candidate employees and the importance of the post-hire outcomes.

44. The method of claim 30 further comprising:
refining the model based on newly-observed post-hire outcomes.

45. The method of claim 30 wherein the pre-hire information comprises answers to questions on a job application, the method further comprising:
identifying one or more questions as ineffective predictors;
5 responsive to identifying the questions as ineffective predictors, modifying the job application by removing the questions;
collecting new pre-hire information for additional candidate employees based on the modified job application;
collecting new post-hire information for the additional candidate employees; and
10 constructing a refined artificial-intelligence model based on the additional pre-hire and post-hire information for the additional candidate employees.

46. The method of claim 45 further comprising:
responsive to determining pre-hire and post-hire information has been collected
15 for a sufficient number of additional employees, providing an indication that a refined model can be constructed.

47. The method of claim 45 further comprising:
providing a report indicating the identified questions are ineffective predictors.
20

48. The method of claim 45 further comprising:
adding one or more new questions to the modified job application before
collecting additional pre-hire information.

49. The method of claim 48 wherein the new questions are composed based
25 on job skills appropriate for a particular job related to the job application.

50. The method of claim 48 further comprising:
evaluating the effectiveness of the new questions.

51. An artificial intelligence-based employee performance prediction system comprising:

- a set of pre-hire characteristic identifiers;
- 5 a set of post-hire outcome identifiers;
- a collection of data for employees, wherein the data includes values associated with the pre-hire identifiers and the post-hire identifiers; and
- an artificial intelligence-based model chosen from a set of candidate models, the artificial intelligence-based model exhibiting superior ability at predicting values
- 10 associated with the post-hire outcome identifiers based on values associated with the pre-hire characteristic identifiers in comparison to the other candidate models.

52. A computer-readable medium having a collection of employment-related data, the data comprising:

- 15 pre-hire information for a plurality of employees, wherein the pre-hire information comprises information electronically-collected from an applicant, wherein the information comprises a plurality of pre-hire characteristics;
- post-hire information for at least some of the plurality of employees, wherein the information comprises a plurality of post-hire outcomes; and
- 20 a data structure identifying which of the pre-hire characteristics are effective in predicting a set of one or more of the post-hire outcomes for a job applicant.

53. A method for providing an automated hiring recommendation for a new potential employee, the method comprising:
- collecting pre-hire information for potential employees;
 - storing the pre-hire information for the potential employees in a database;
 - 5 after hiring a plurality of the potential employees, collecting employment performance information for at least some of the hired employees;
 - storing the employment performance information collected from the hired employees;
 - constructing an artificial intelligence-based model based on correlations between
 - 10 the pre-hire information and the employment performance information collected from one or more of the hired employees;
 - collecting pre-hire information for a new potential employee;
 - based on the artificial intelligence-based model, providing an automated hiring recommendation for the new potential employee;
 - 15 after hiring the new potential employee, collecting employment performance information for the new potential employee;
 - adding the employment performance information for the new potential employee to the database; and
 - 20 modifying the artificial intelligence-based model based on the pre-hire and employment performance information for the new potential employee.

54. A method for providing an automated hiring recommendation service for an employer, the method comprising:

stationing a plurality of electronic devices at a plurality of employer sites, wherein the electronic devices are operable to accept directly from one or more job applicants answers to questions presented at the electronic devices;

5 sending the answers of at least one of the job applicants to a remote site for analysis;

applying an artificial intelligence-based predictive model to the answers of the least one of the job applicant to generate an automated hiring recommendation; and

10 automatically sending the hiring recommendation to the employer.

55. A method of constructing a model generating one or more job performance criteria predictors based on input pre-hire information, the method comprising:

15 from a plurality of applicants, electronically collecting pre-hire information from the applicants;

collecting post-hire information for the applicants based on job performance of the applicants after hire; and

20 from the pre-hire information and the post-hire information, generating an artificial intelligence-based predictive model operable to generate one or more job performance criteria predictors based on input pre-hire information from new applicants.

56. A computer-readable medium comprising computer-executable instructions for performing the method of claim 55.

57. The method of claim 55 further comprising:

limiting the applicants for the model to those from a particular geographic area; and

constructing the model as a geographically-specialized model.

58. The method of claim 55 further comprising:
limiting the applicants for the model to those with a particular educational level;
5 and
constructing the model as an educational level-specialized model.

59. The method of claim 55 further comprising:
limiting the applicants for the model to those with a particular occupation; and
10 constructing the model as an occupationally-specialized model.

60. The method of claim 55 wherein the model accepts one or more inputs,
the method further comprising:
identifying in the pre-hire information one or more characteristics that are
15 ineffective predictors; and
omitting the ineffective predictors as inputs to the model.

61. The method of claim 55 wherein the pre-hire information comprises one
or more characteristics, the method further comprising:
20 identifying in the pre-hire information one or more characteristics that are
ineffective predictors; and
providing an indication that the characteristics no longer need to be collected.

62. The method of claim 55 wherein job performance criteria predictors
25 comprise a predictor indicating whether a job candidate will be voluntarily terminated.

63. The method of claim 55 wherein job performance criteria predictors
comprise a predictor indicating whether a job candidate will be eligible for rehire after
termination.

64. The method of claim 55 wherein the pre-hire information comprises one or more characteristics, the method further comprising:

- 5 identifying in the pre-hire information one or more characteristics that are ineffective predictors; and
responsive to identifying the ineffective predictors, collecting new pre-hire information not including the ineffective predictors; and
building a refined model based on the new pre-hire information.

10 65. The method of claim 64 further comprising:
adding one or more new characteristics to be collected when collecting the new pre-hire information.

15 66. The method of claim 65 further comprising:
evaluating the effectiveness of the new characteristics.

67. A method of constructing a model predicting employment performance based on a set of input employment parameters, the method comprising:
20 selecting a set of input parameters indicating pre-hire characteristics of an employee, wherein the pre-hire characteristics are available before hiring the employee and are collected electronically from the employee;
selecting a set of output parameters indicating post-hire outcomes available after hiring the employee; and
training a neural network with the input and output parameters.

25

68. The method of claim 67 further comprising:
choosing a set of one or more candidate characteristics, wherein the
characteristics indicate data available before hiring an employee;
testing effectiveness of the candidate characteristics in predicting the post-hire
5 characteristics; and
responsive to determining the candidate information is effective, incorporating
the candidate information into the model.

69. A method for constructing an artificial intelligence-based employment
10 selection process based on pre-hire information comprising personal employee
characteristics and post-hire information comprising employee job performance
observation information, the method comprising:
generating a plurality of predictive artificial intelligence models based on the
pre-hire and post-hire information, wherein at least two of the artificial intelligence
15 models are of different types;
testing effectiveness of the models to select an effective model; and
applying the effective model to predict post-hire information not yet observed.

70. The method of claim 69 wherein at least one of the models is a neural
20 network.

71. The method of claim 70 wherein at least one of the models is an expert
system.

72. The method of claim 69 wherein at least one of the models is a fuzzy
25 logic system.

73. The method of claim 69 wherein at least one of the models is an
information theoretic model.

74. The method of claim 69 wherein at least one of the models is a neuro-fuzzy model.

5 75. The method of claim 69 further comprising:
identifying at least one of the models as exhibiting impermissible bias; and
avoiding use of the models exhibiting impermissible bias.

76. The method of claim 75 wherein the impermissible bias is against a
10 protected group of persons.

77. A computer-implemented method of refining an artificial-intelligence based employee performance selection system, the method comprising:
collecting information via an electronic device presenting a set of questions to
15 employment candidates, wherein the questions are stored in a computer-readable medium;
testing effectiveness of at least one of the questions in predicting the post-hire information; and
responsive to determining the question is ineffective, deleting the question from
20 the computer-readable medium.

78. The method of claim 77 wherein effectiveness comprises predictiveness tested based on information theoretic techniques.

79. A computer-readable medium comprising a predictive model, the model comprising:

inputs for accepting one or more characteristics based on pre-hire information for a job applicant;

5 one or more predictive outputs indicating one or more predicted job effectiveness criteria based on the inputs,

wherein the predictive model is an artificial intelligence-based model constructed from pre-hire data electronically collected from a plurality of employees and post-hire data, and the model generates its predictive outputs based on the similarity of
10 the inputs to pre-hire data collected for the plurality of employees and their respective post-hire data.

80. The computer-readable medium of claim 79 wherein the predictive model comprises a predictive output indicating a rank for the job applicant.

15

81. The computer-readable medium of claim 80 wherein the rank is relative to other applicants.

82. The computer-readable medium of claim 80 wherein the rank is relative
20 to the plurality of employees.

83. The computer-readable medium of claim 79 wherein the predictive model comprises a predictive output indicating probability of group membership for the job applicant.

25

84. The computer-readable medium of claim 79 wherein the predictive model comprises a predictive output indicating predicted tenure for the job applicant.

85. The computer-readable medium of claim 79 wherein the predictive model comprises a predictive output indicating predicted tenure for the job applicant.

5 86. The computer-readable medium of claim 79 wherein the predictive model comprises a predictive output indicating predicted number of accidents for the job applicant.

87. The computer-readable medium of claim 79 wherein the predictive model comprises a predictive output indicating whether the applicant will be
10 involuntarily terminated.

88. The computer-readable medium of claim 79 wherein the predictive model comprises a predictive output indicating whether the applicant will be eligible for
15 rehire after termination.

89. A computer-readable medium comprising a refined predictive model, the model comprising:

inputs for accepting one or more characteristics based on pre-hire information for a job applicant;

20 one or more predictive outputs indicating one or more predicted job effectiveness criteria based on the inputs,

wherein the predictive model is constructed from pre-hire data electronically collected from a plurality of employees and post-hire data, wherein the pre-hire data is based on a question set refined by having identified and removed one or more questions
25 as ineffective.

90. The computer-readable medium of claim 89 wherein the ineffective questions are identified via an information transfer technique.

91. The computer-readable medium of claim 89 wherein the model is an artificial intelligence-based model.

5

FIG. 1

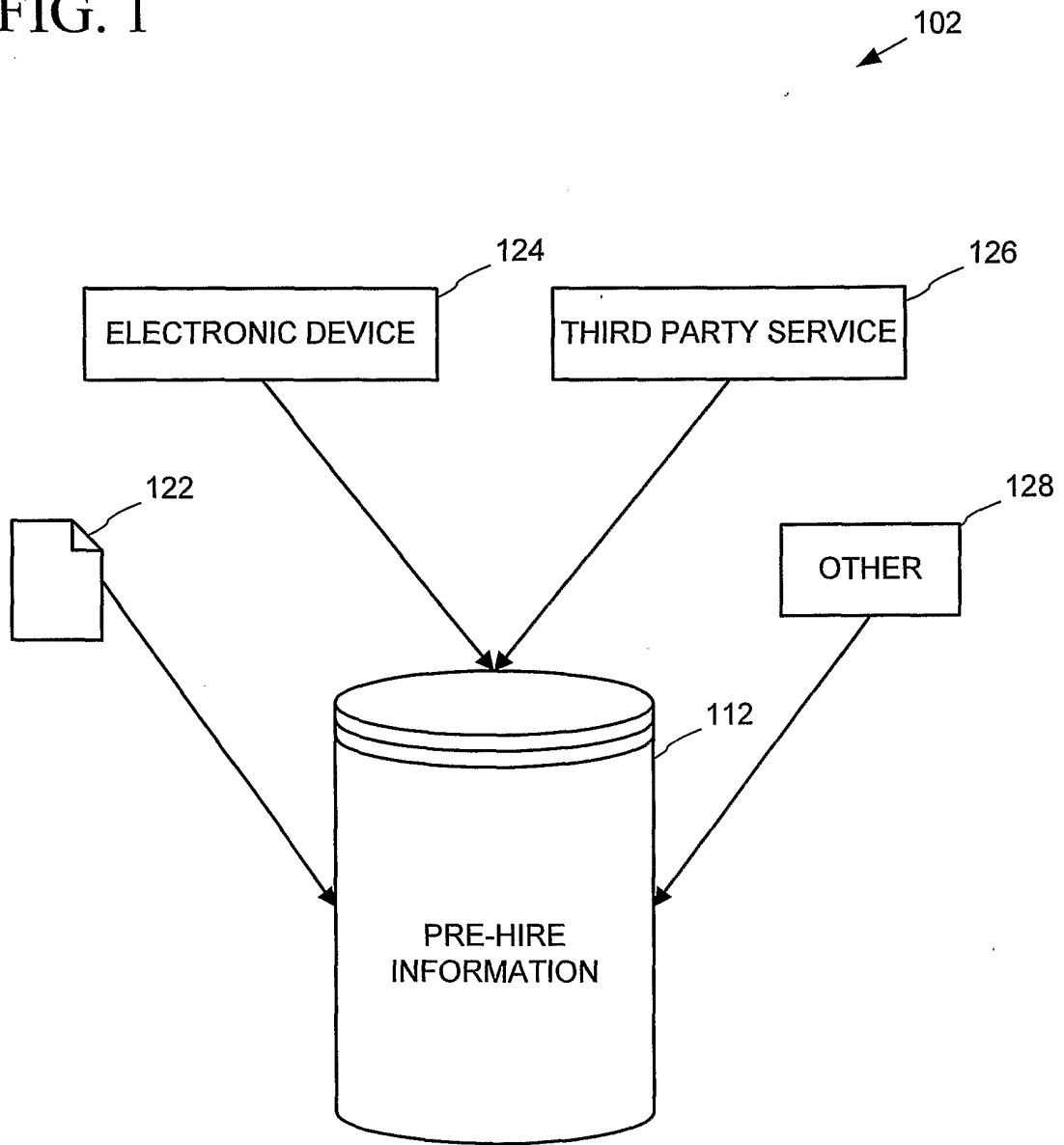

FIG. 2

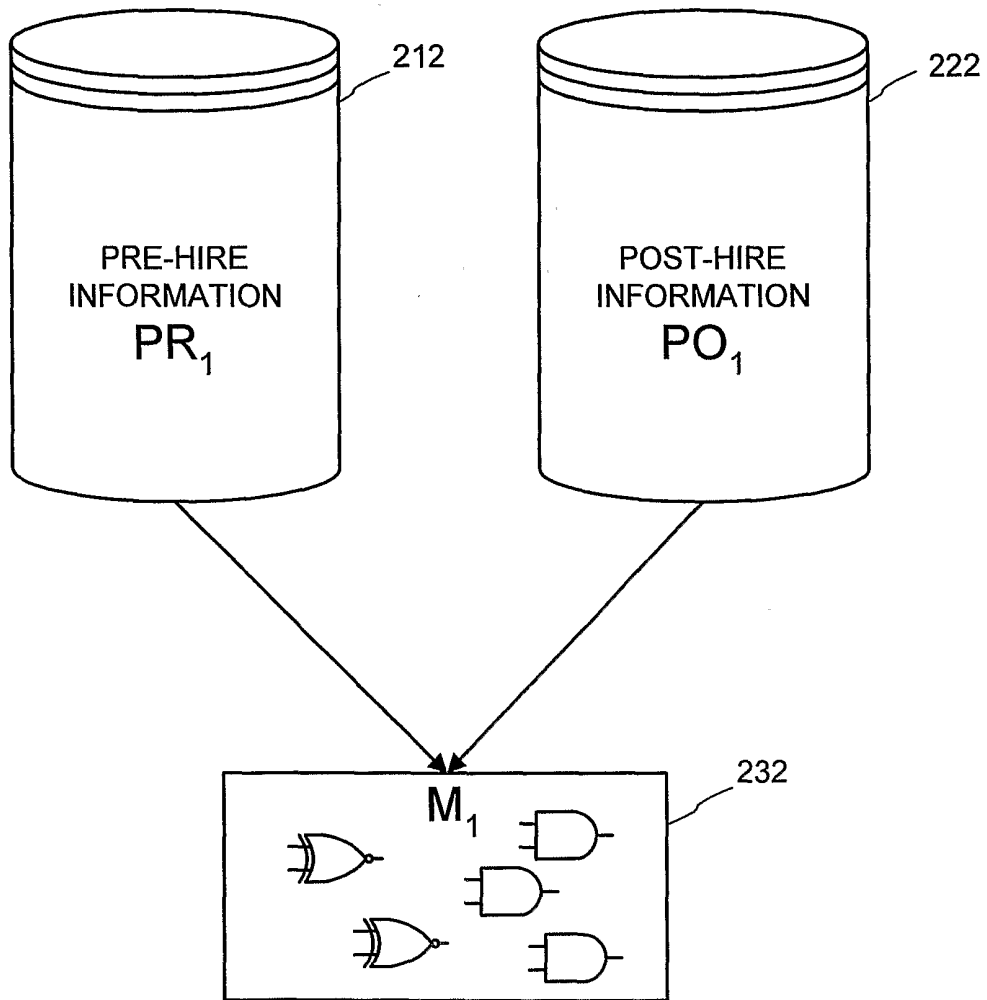

FIG. 3

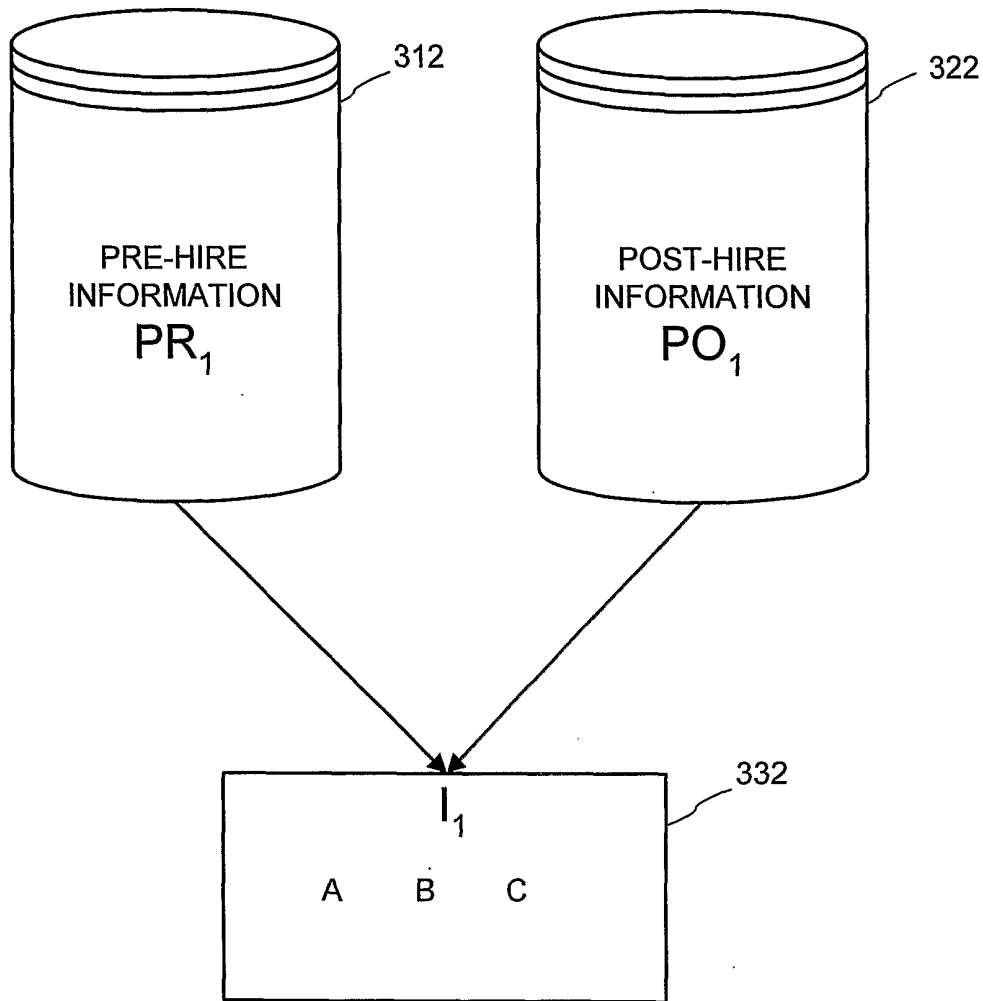

FIG. 4

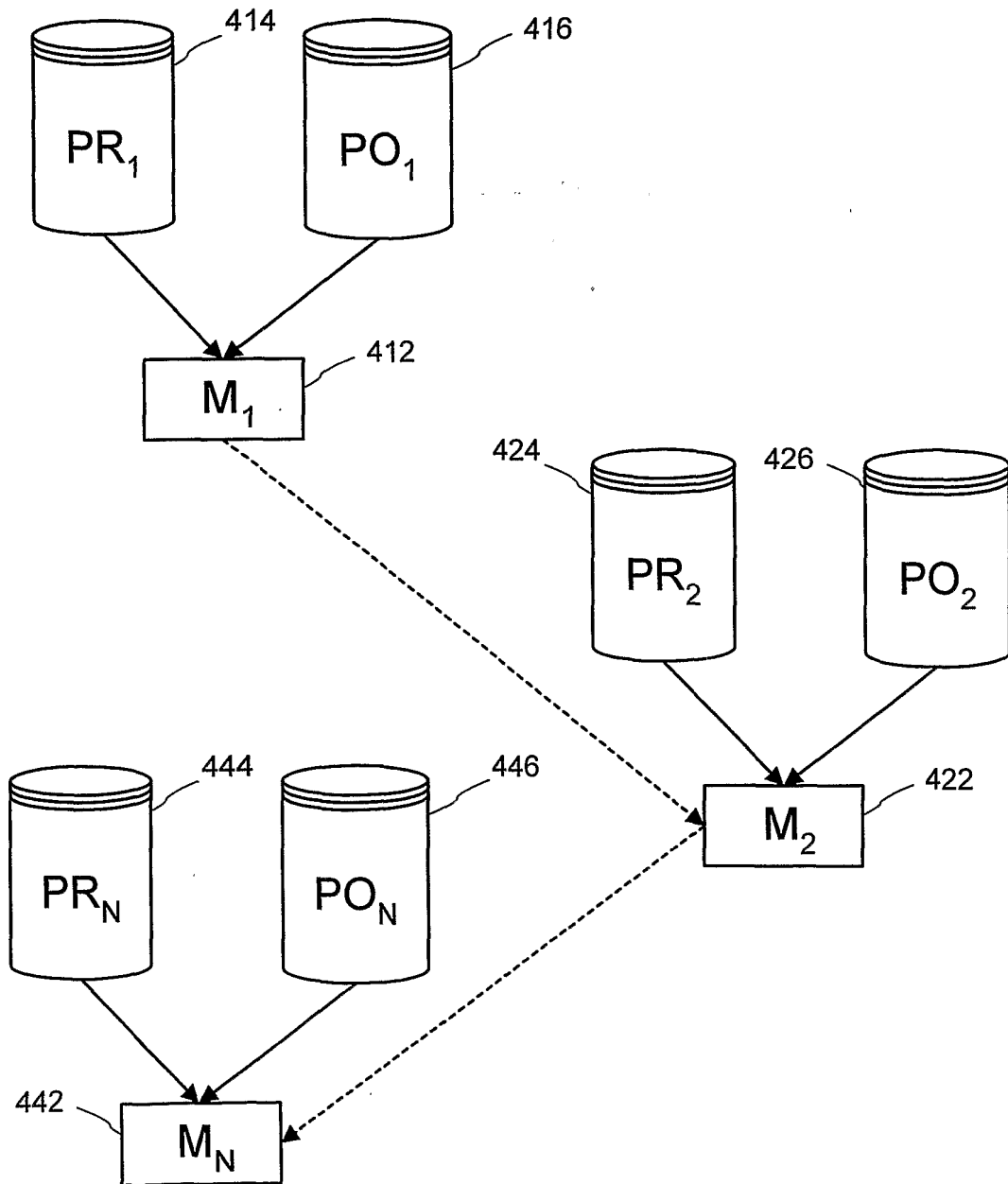

FIG. 5

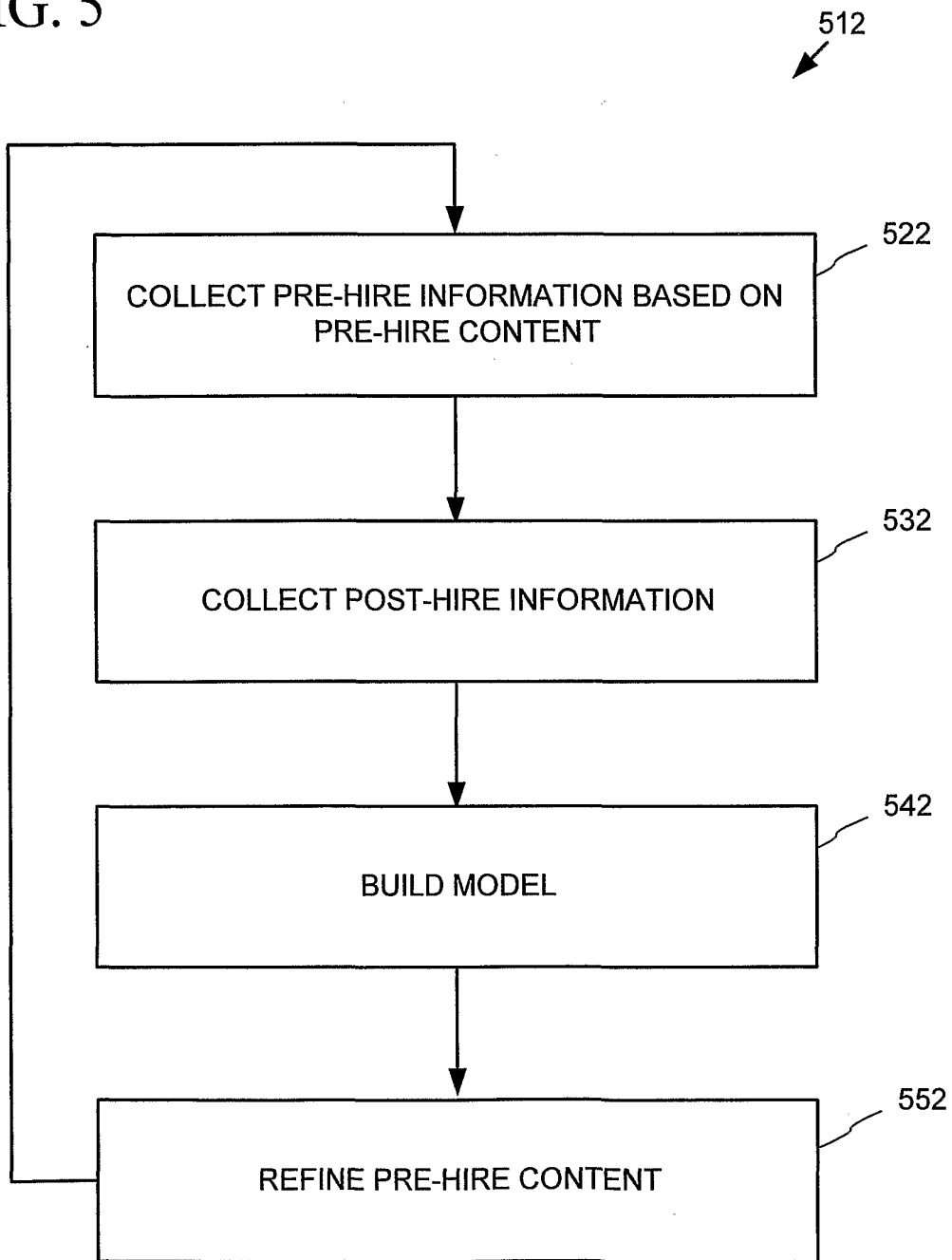

FIG. 6

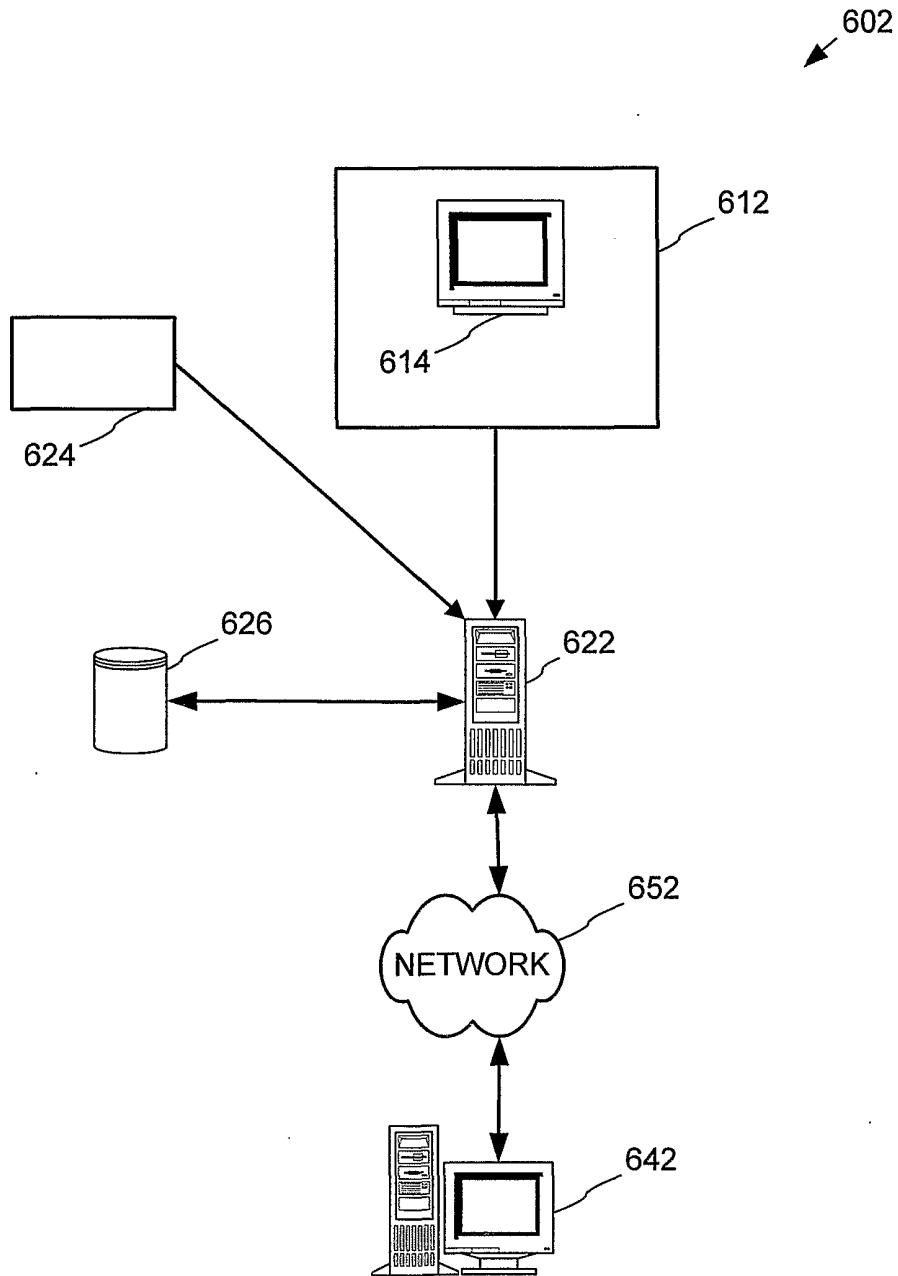

FIG. 7

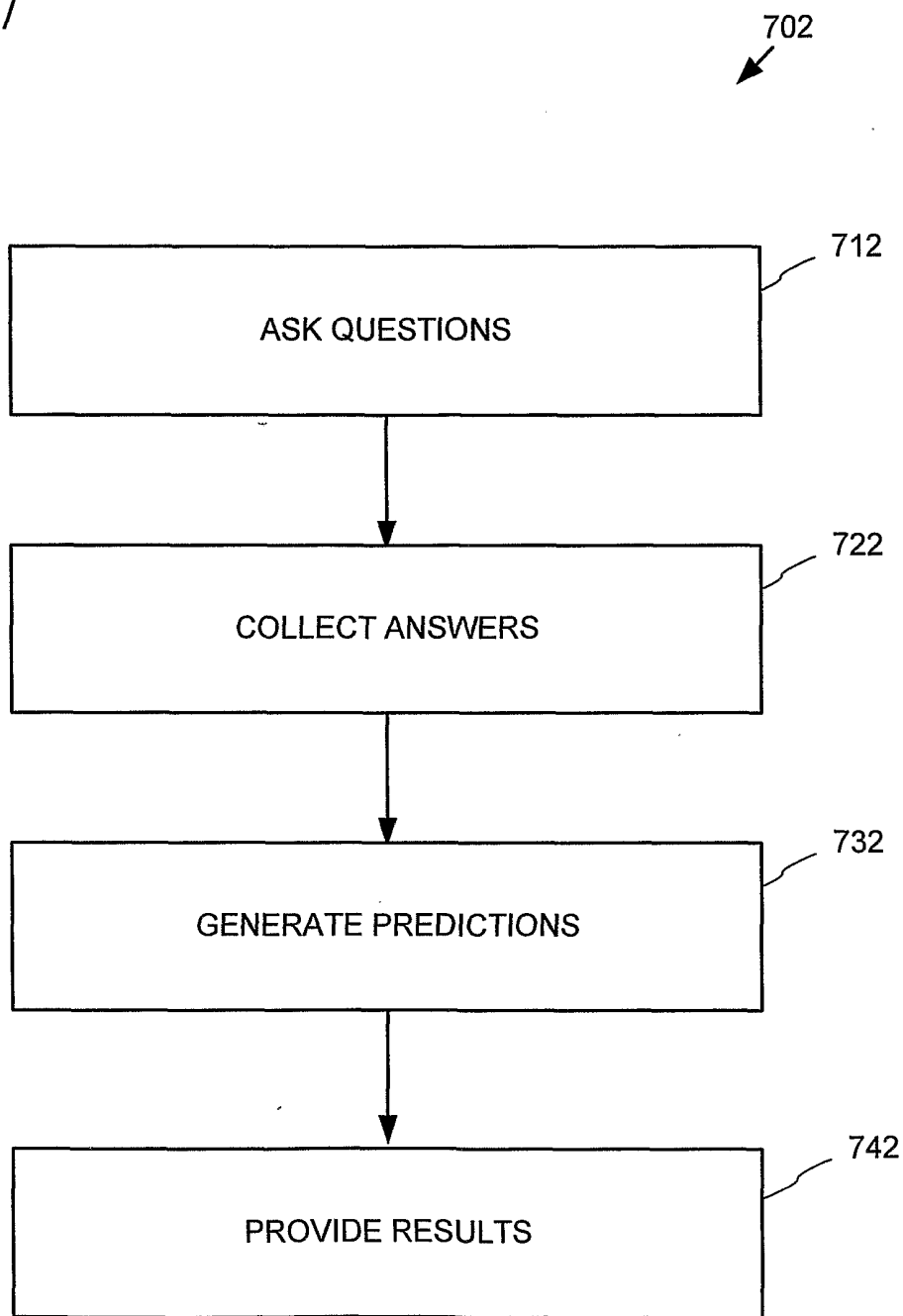

FIG. 8

802
↙

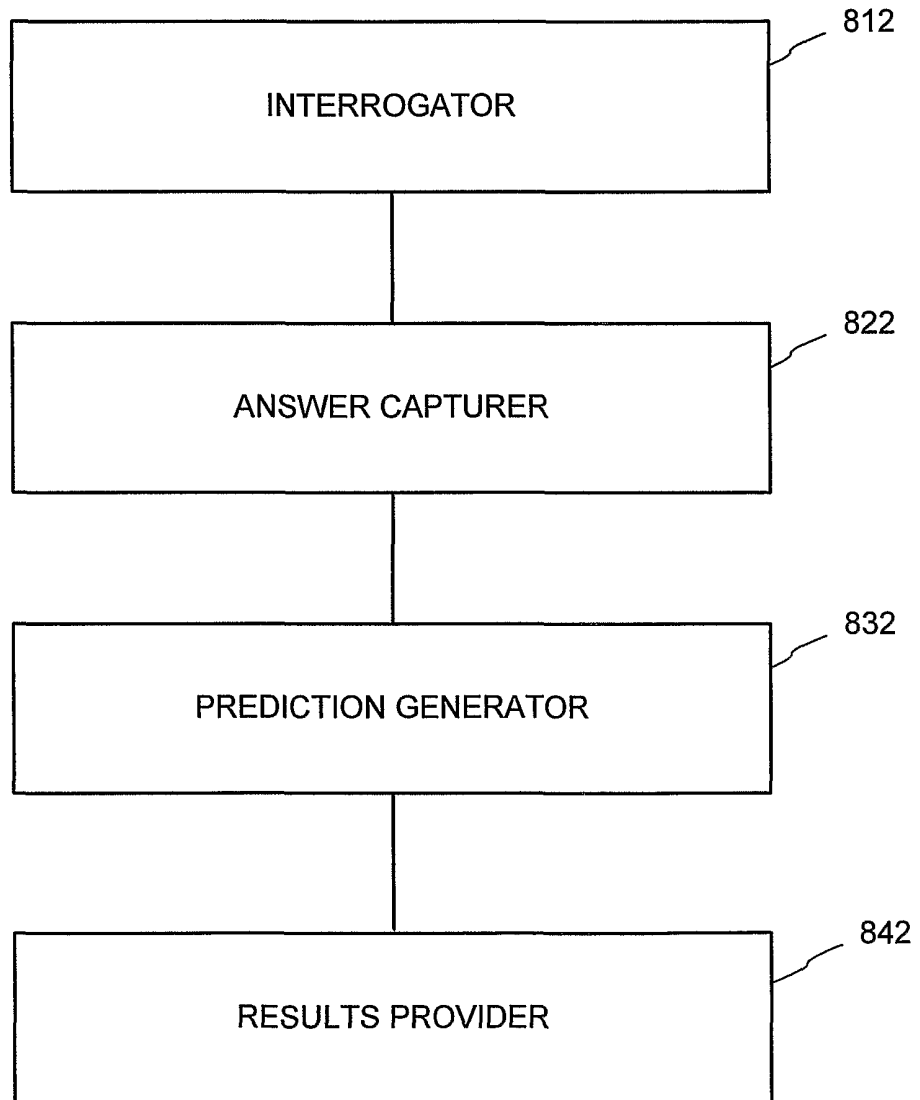

FIG. 9

902

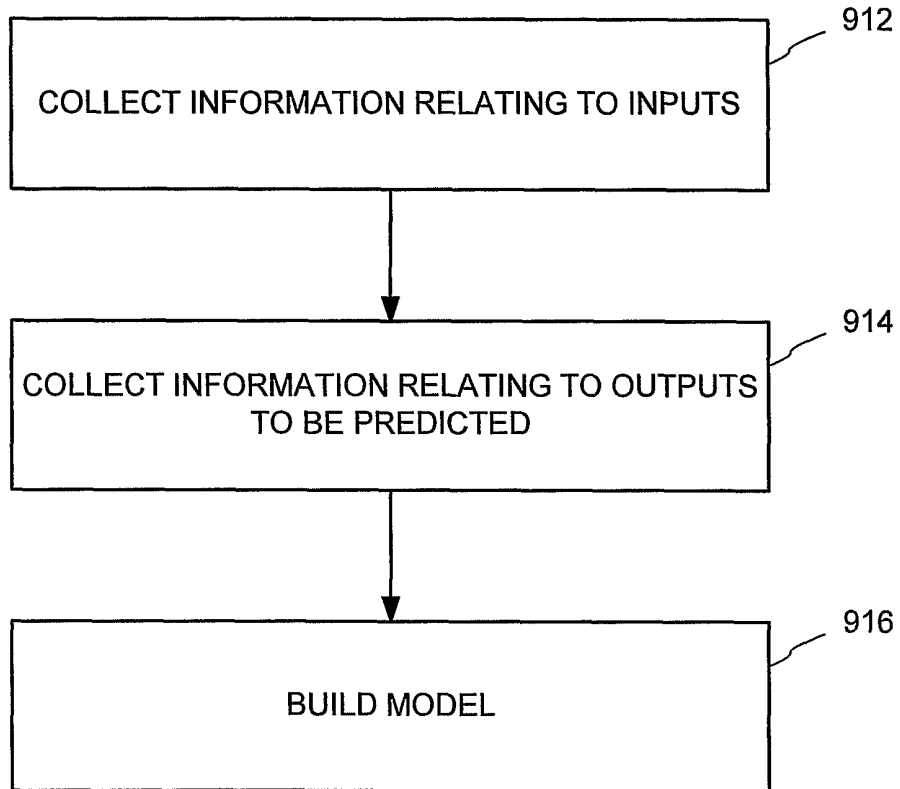



FIG. 10

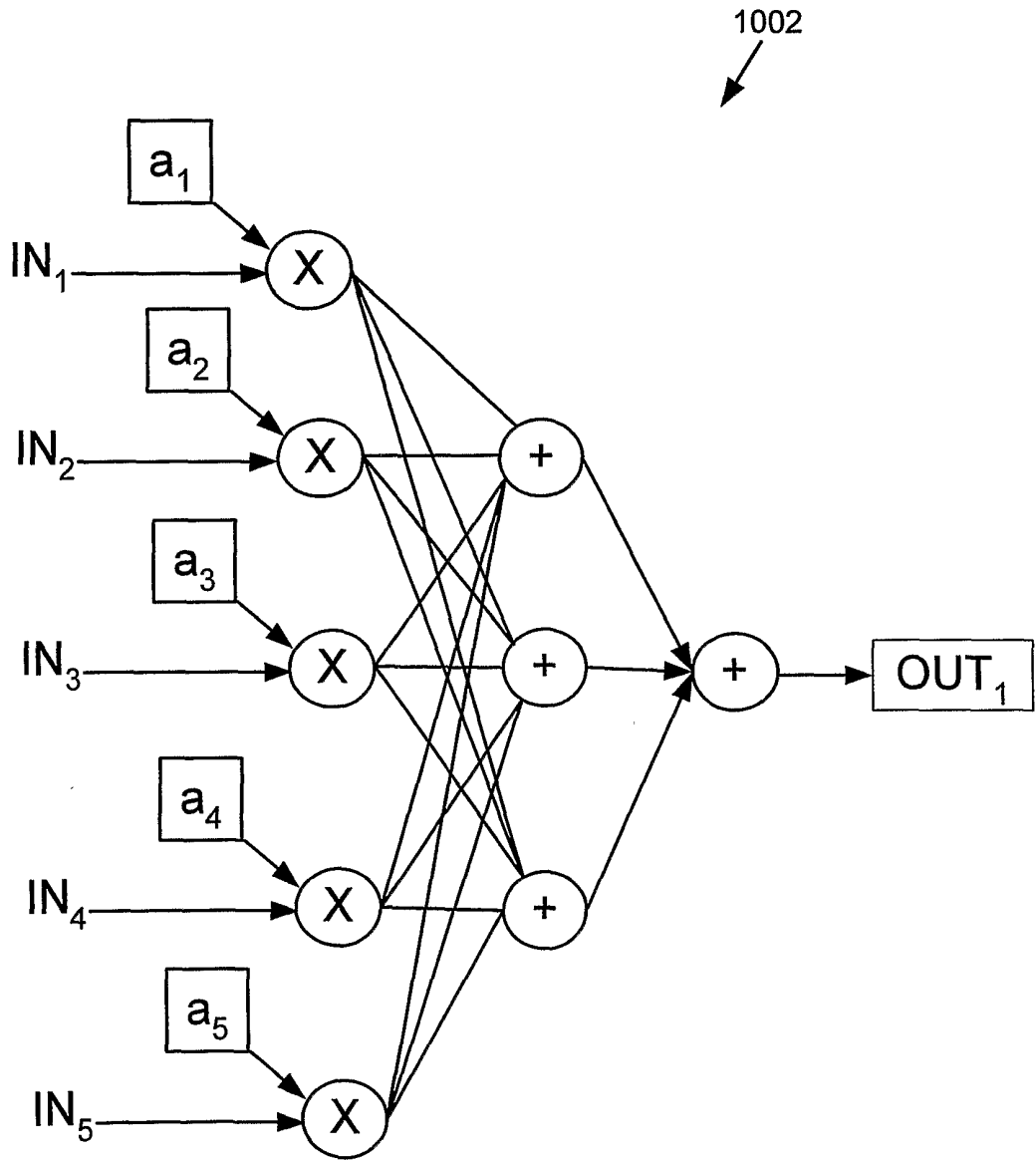
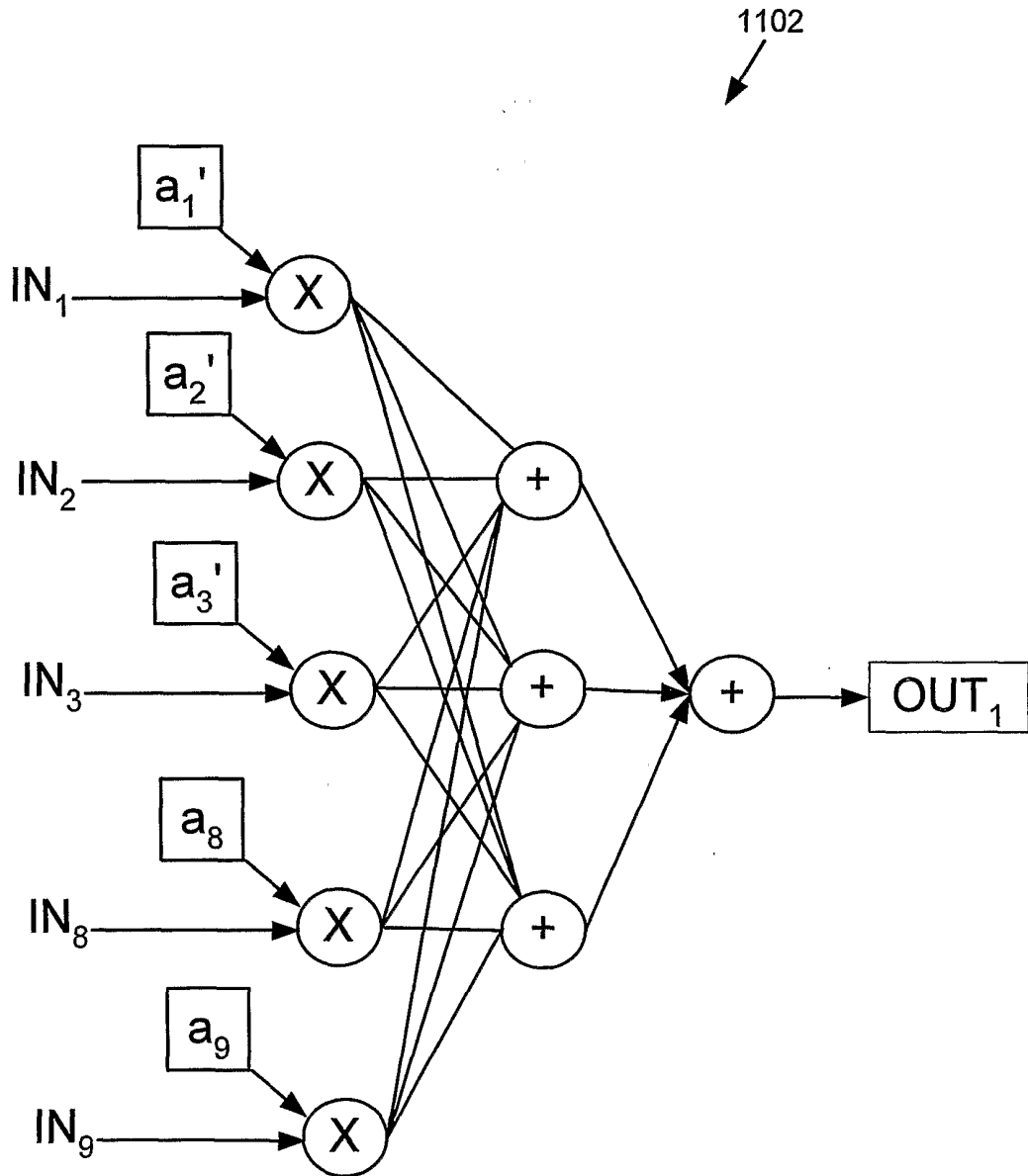

FIG. 11



12/20

FIG. 12

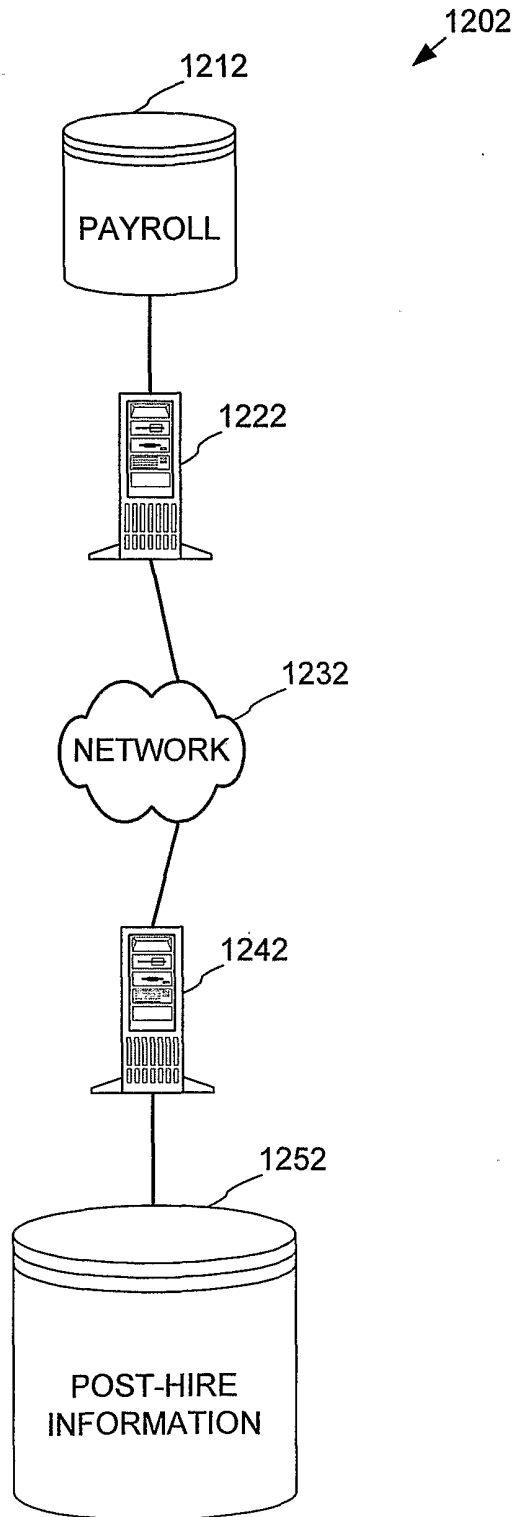

FIG. 14A

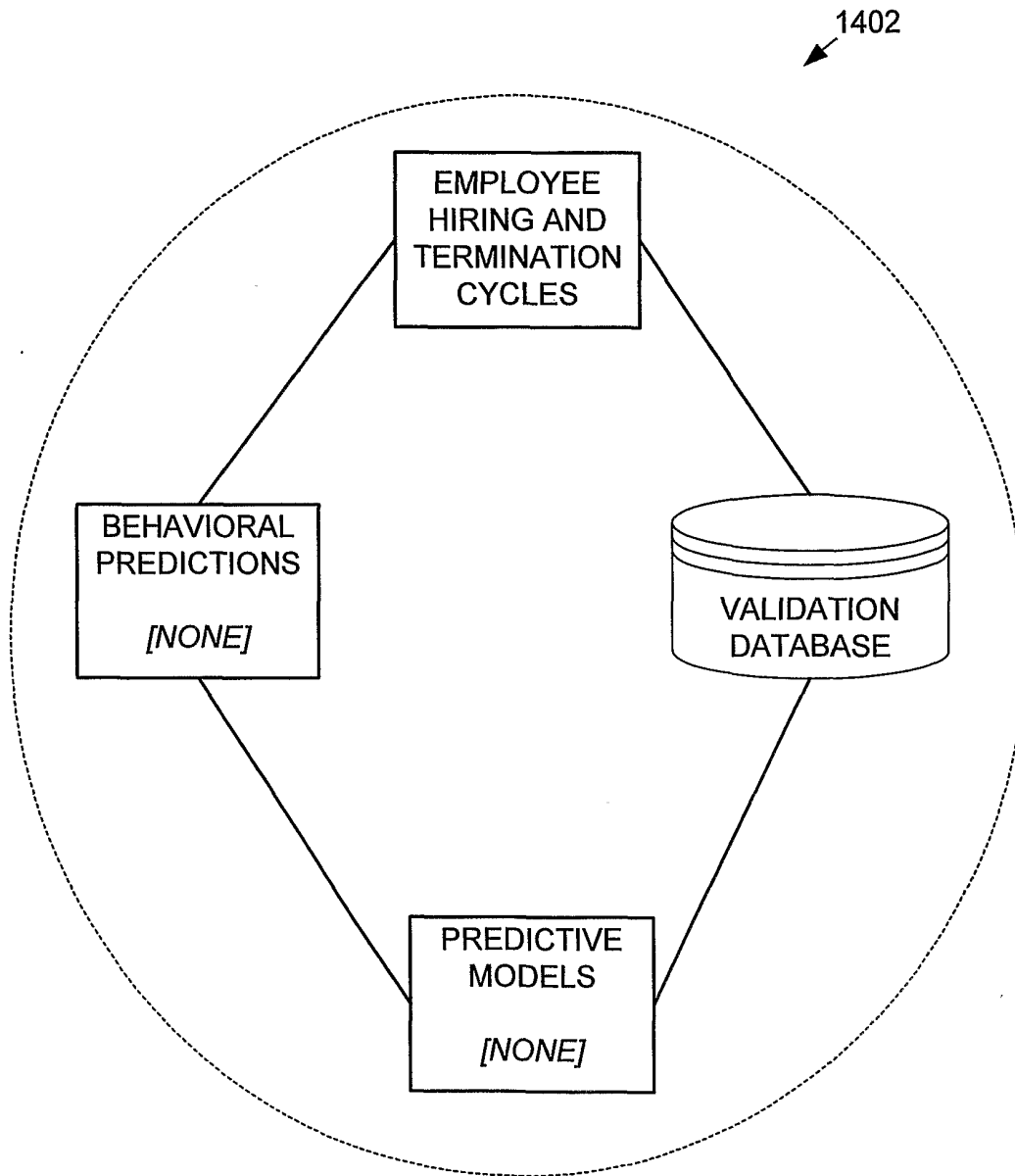

FIG. 14B

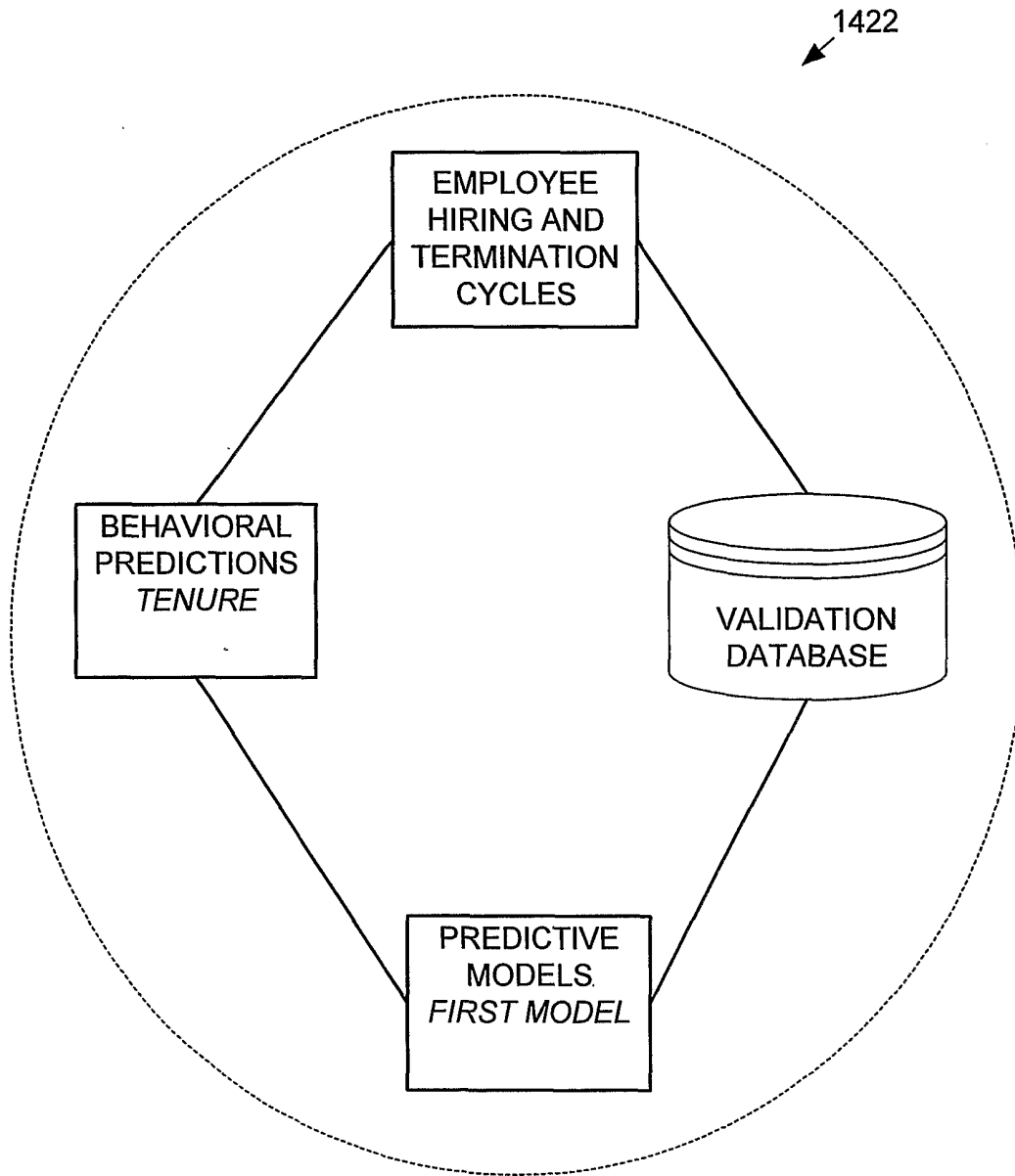

FIG. 14C

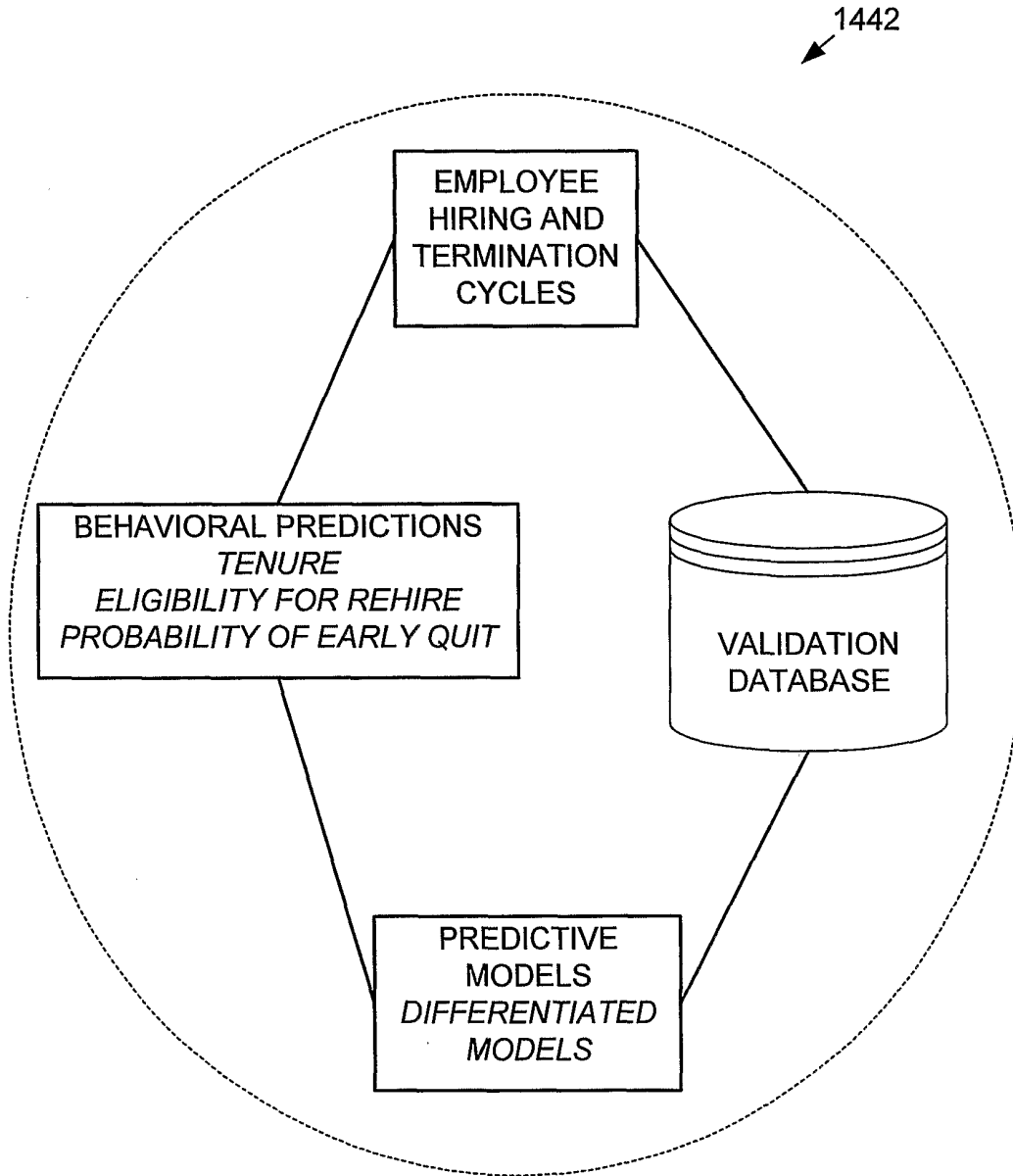

FIG. 14D

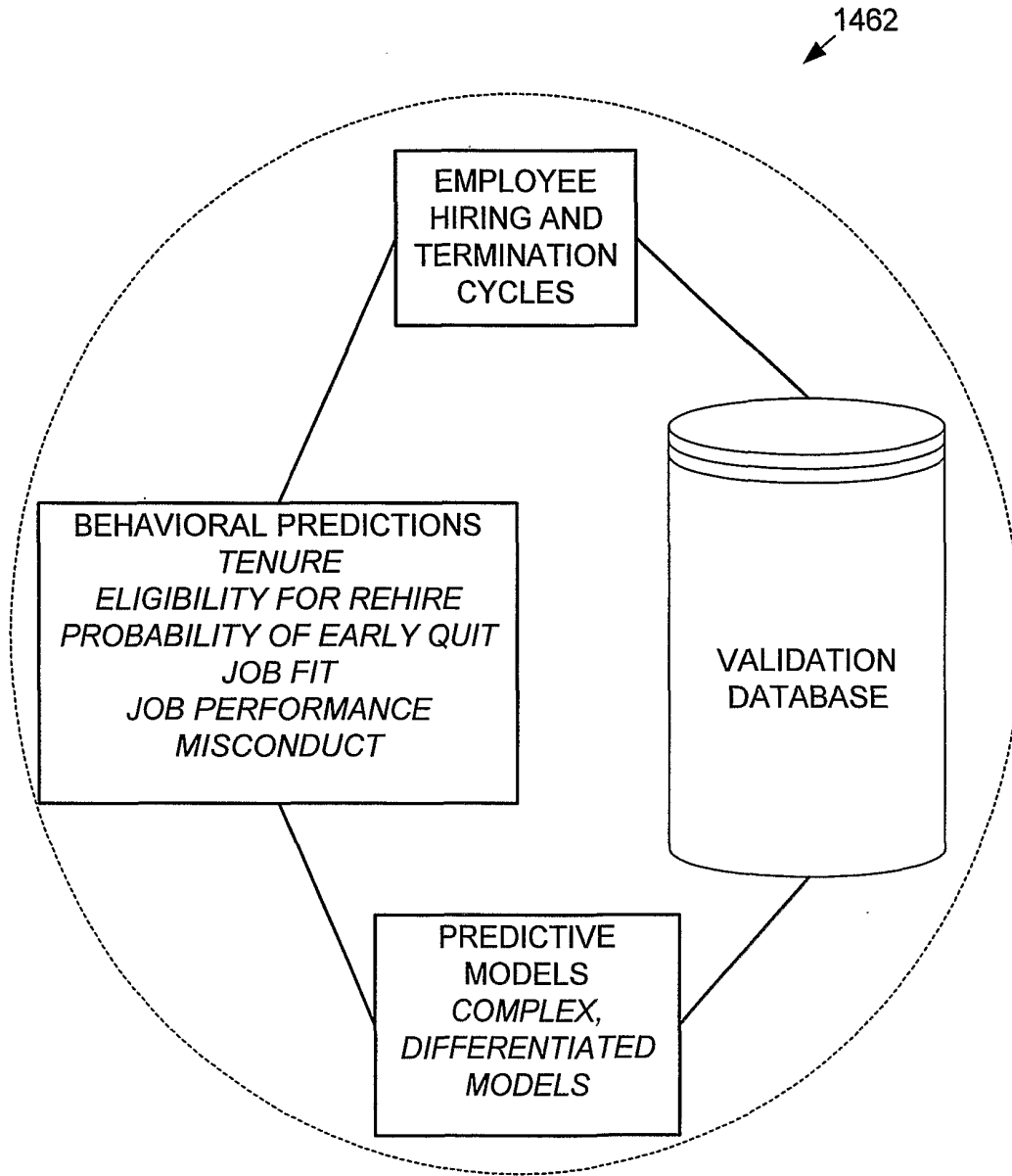

FIG. 15

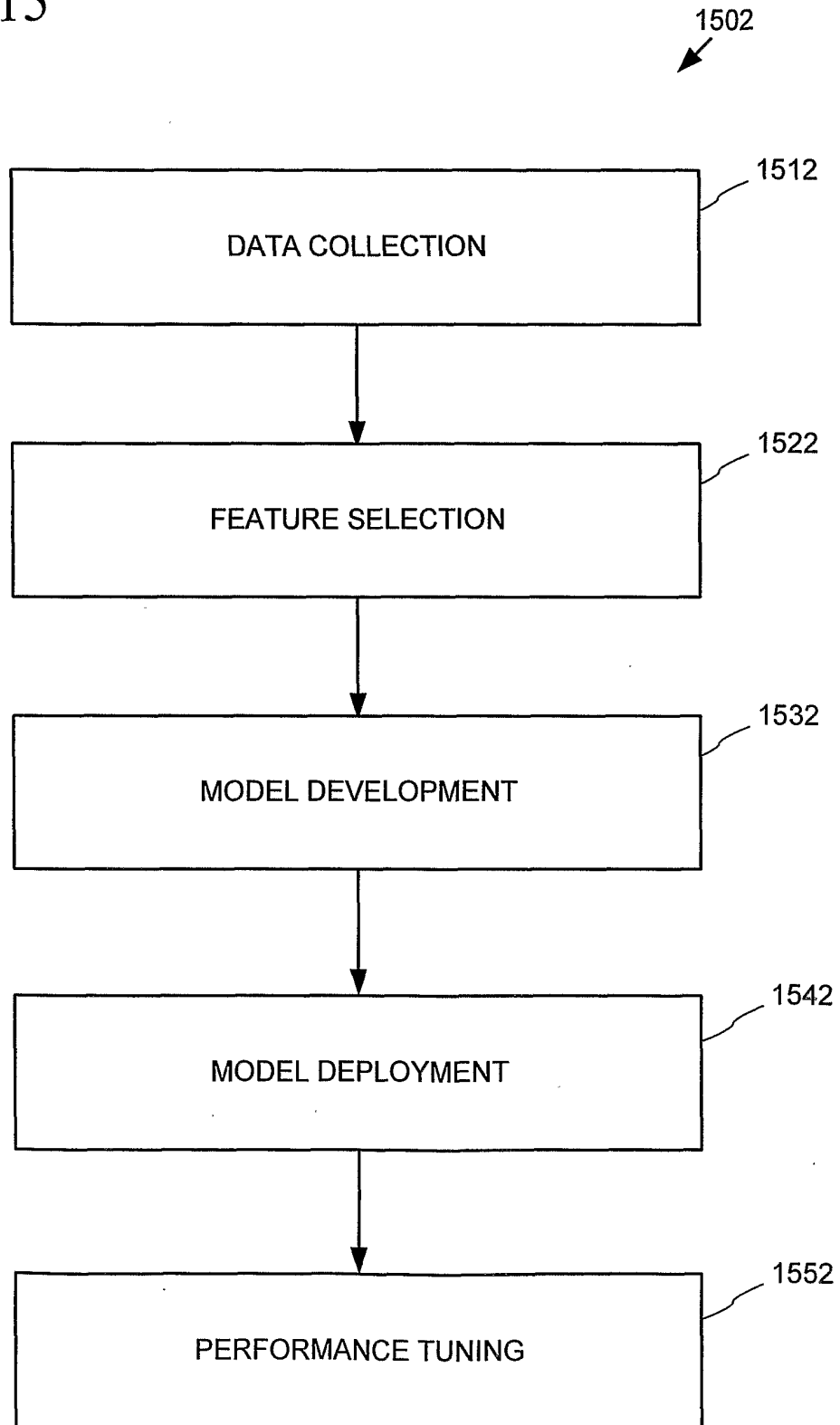

FIG. 16

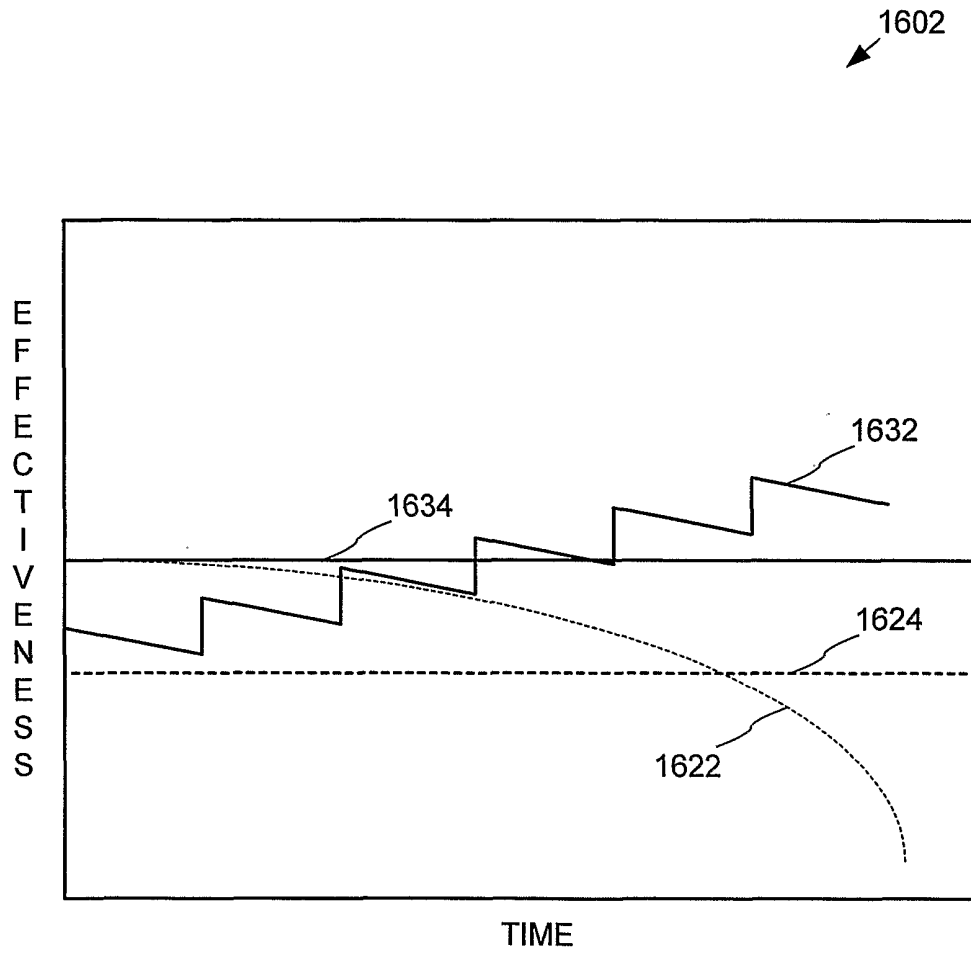
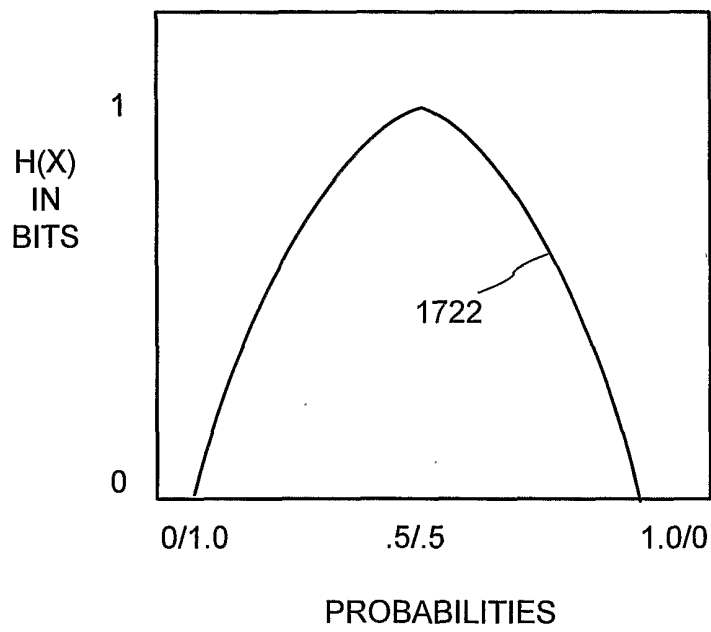

FIG. 17

1702



PATENT COOPERATION TREATY

PCT

DECLARATION OF NON-ESTABLISHMENT OF INTERNATIONAL SEARCH REPORT

(PCT Article 17(2)(a), Rules 13ter.1(c) and Rule 39)

Applicant's or agent's file reference 5437-60779	IMPORTANT DECLARATION	Date of mailing(day/month/year) 26/09/2001
International application No. PCT/US 01/ 24323	International filing date(day/month/year) 02/08/2001	(Earliest) Priority date(day/month/year) 03/08/2000
International Patent Classification (IPC) or both national classification and IPC		G06F17/60
Applicant UNICRU, INC.		

This International Searching Authority hereby declares, according to Article 17(2)(a), that **no international search report will be established** on the international application for the reasons indicated below

1. The subject matter of the international application relates to:
 - a. scientific theories.
 - b. mathematical theories
 - c. plant varieties.
 - d. animal varieties.
 - e. essentially biological processes for the production of plants and animals, other than microbiological processes and the products of such processes.
 - f. schemes, rules or methods of doing business.
 - g. schemes, rules or methods of performing purely mental acts.
 - h. schemes, rules or methods of playing games.
 - i. methods for treatment of the human body by surgery or therapy.
 - j. methods for treatment of the animal body by surgery or therapy.
 - k. diagnostic methods practised on the human or animal body.
 - l. mere presentations of information.
 - m. computer programs for which this International Searching Authority is not equipped to search prior art.

2. The failure of the following parts of the international application to comply with prescribed requirements prevents a meaningful search from being carried out:

<input type="checkbox"/> the description	<input type="checkbox"/> the claims	<input type="checkbox"/> the drawings
--	-------------------------------------	---------------------------------------

3. The failure of the nucleotide and/or amino acid sequence listing to comply with the standard provided for in Annex C of the Administrative Instructions prevents a meaningful search from being carried out:

<input type="checkbox"/> the written form has not been furnished or does not comply with the standard.
<input type="checkbox"/> the computer readable form has not been furnished or does not comply with the standard.

4. Further comments:

Name and mailing address of the International Searching Authority  European Patent Office, P.B. 5818 Patentlaan 2 NL-2280 HV Rijswijk Tel. (+31-70) 340-2040, Tx. 31 651 epo nl, Fax: (+31-70) 340-3016	Authorized officer María Rodríguez Nóvoa
--	---

FURTHER INFORMATION CONTINUED FROM PCT/ISA/ 203

The subject-matter claimed in claims 25-27, 30-50, 53-55 and 57-78 falls under the provisions of Article 17(2)(a)(i) and Rule 39.1(i, iii) PCT, such subject-matter relating to a method of doing business, a scientific theory and a mathematical method.

Claims 1-24, 28-29, 51-52, 56 and 79-91 relate to commonplace technological features for performing the business and mathematical method, using a scientific theory. Although these claims do not literally belong to the method category, they essentially claim protection for the same effects as the method claims. With reference to the Guidelines, B-VIII, points 1-6, the International Searching Authority considers that searching such features would serve no useful purpose. This applies to the remaining commonplace technological features of these claims as well.

The applicant's attention is drawn to the fact that claims relating to inventions in respect of which no international search report has been established need not be the subject of an international preliminary examination (Rule 66.1(e) PCT). The applicant is advised that the EPO policy when acting as an International Preliminary Examining Authority is normally not to carry out a preliminary examination on matter which has not been searched. This is the case irrespective of whether or not the claims are amended following receipt of the search report or during any Chapter II procedure. If the application proceeds into the regional phase before the EPO, the applicant is reminded that a search may be carried out during examination before the EPO (see EPO Guideline C-VI, 8.5), should the problems which led to the Article 17(2) declaration be overcome.