

(12) UK Patent Application (19) GB (11) 2 095 738 A

- (21) Application No **8109634**
(22) Date of filing **27 Mar 1981**
(43) Application published
6 Oct 1982
(51) INT CL³
E06B 3/66
(52) Domestic classification
E1R 18B
(56) Documents cited
GB 1529021
GB 1301651
GB 1298829
GB 1152691
GB 0897845
(58) Field of search
E1R
(71) Applicants
Glaverbel,
Chausse de La Hulpe 166,
Watermael-Boitsfort,
Belgium
(72) Inventors
Jacques Falisse,
Robert Vanderstukken,
Jean-Claude Hoyois
(74) Agents
Hyde, Heide and
O'Donnell,
2 Serjeants' Inn, London
EC4Y 1LL

(54) **Hollow glazing panels**

(57) A decorative light transmitting hollow glazing panel comprises a figured glazing sheet 12 and at least one other glazing sheet 11 and at

least one sheet face bears a coating 15 adapted to enhance the reflectivity of the coated sheet face in respect of visible light radiation. In another aspect, the other sheet 11 is a sheet of tinted glazing material.

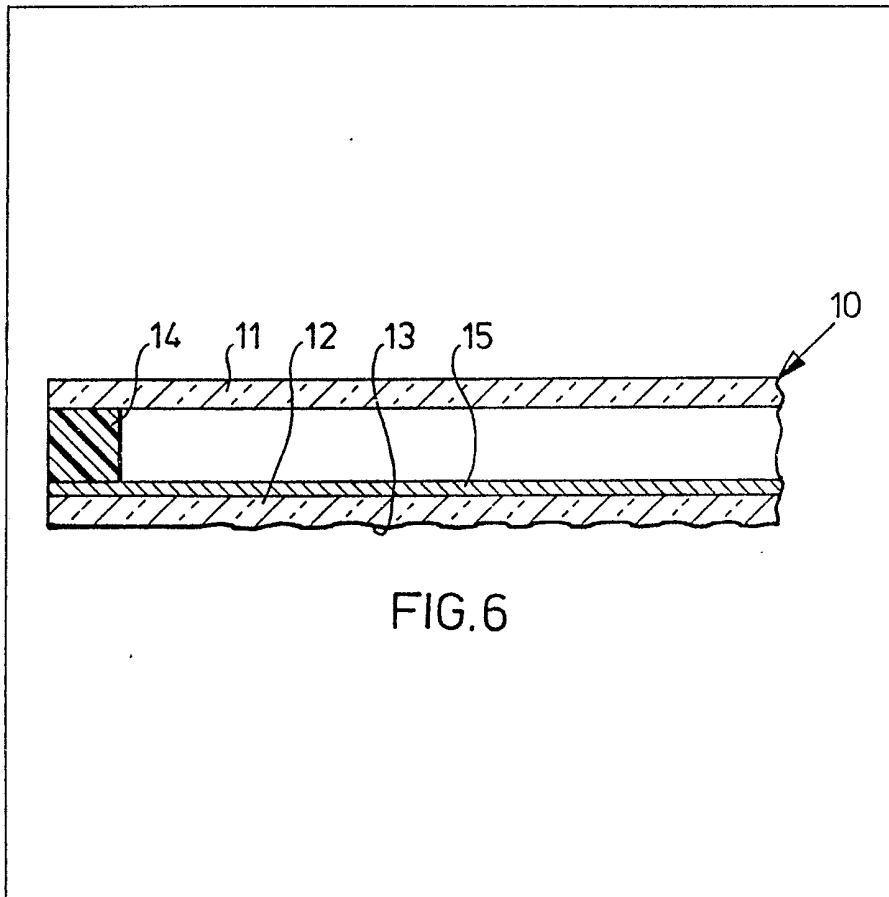

GB 2 095 738 A

FIG.1

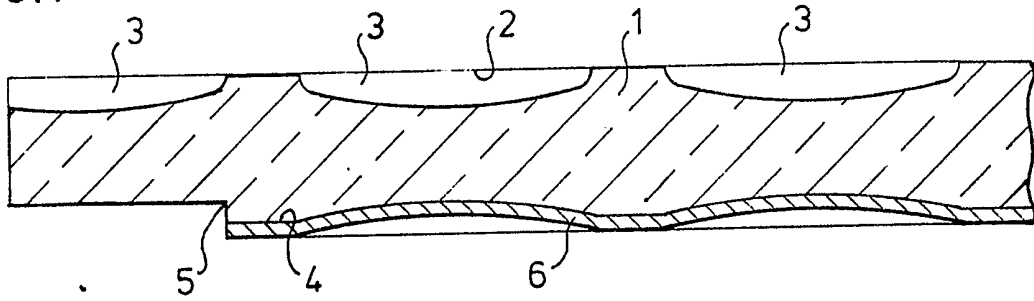

FIG.2

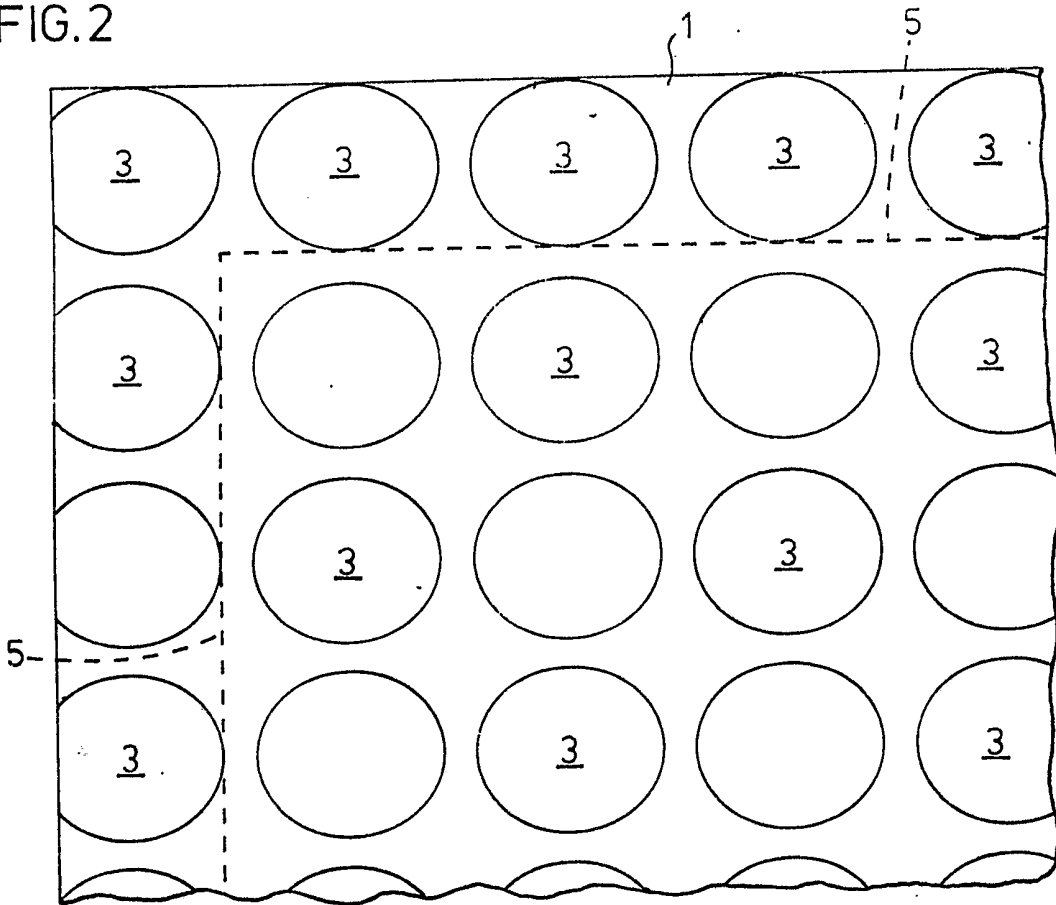

FIG.3

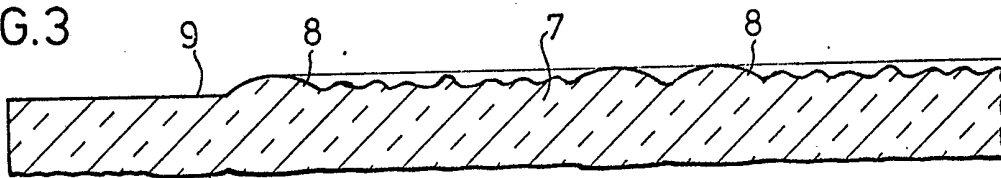

FIG.4

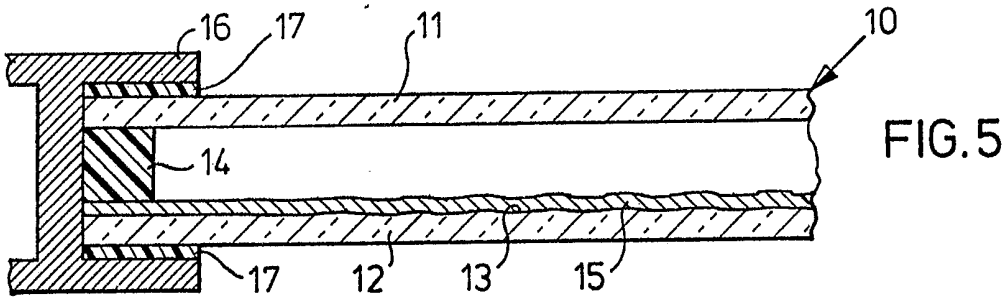
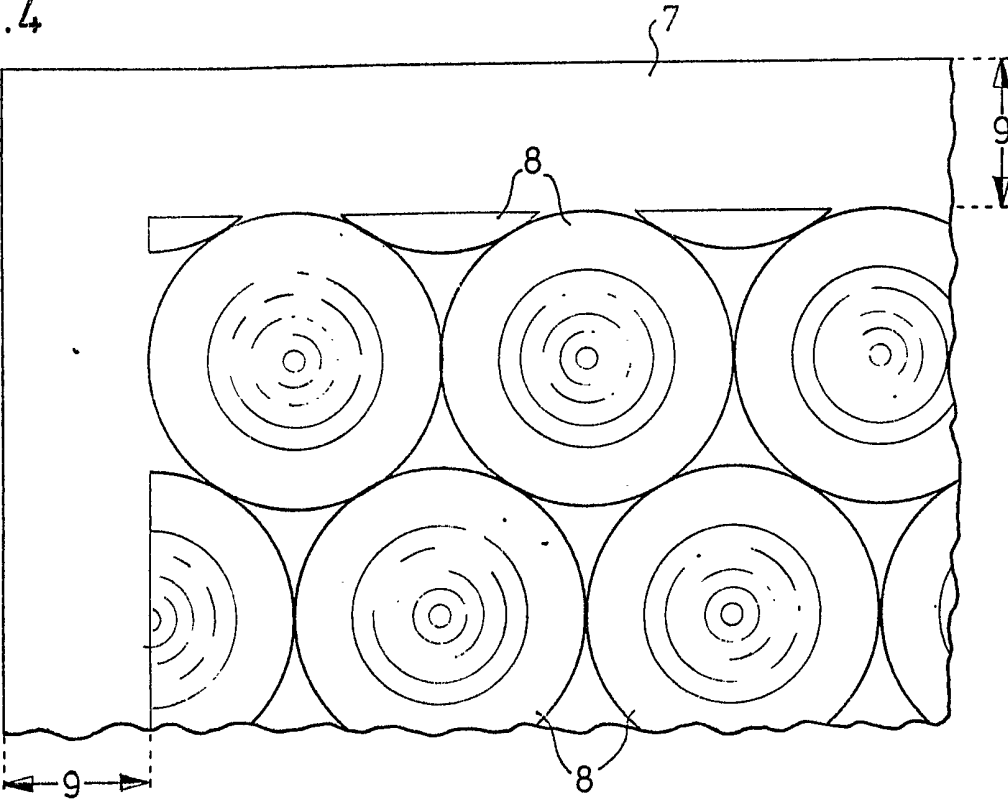

FIG.5

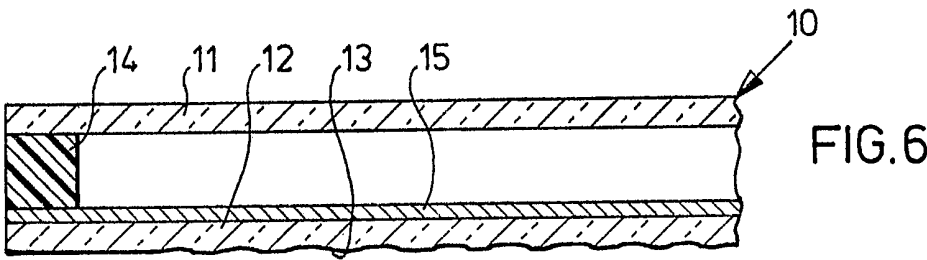

FIG.6

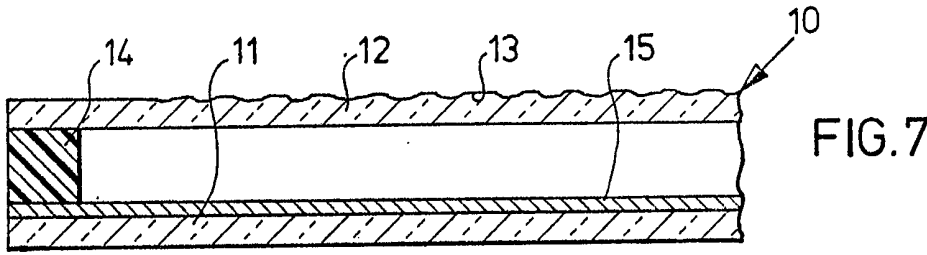

FIG.7

SPECIFICATION
Hollow glazing panels

The present invention relates to hollow light-transmitting glazing panels.

In modern architectural practice, glazed curtain walls are often used. Hitherto, the glazing panels
5 for forming these walls have been made of flat, e.g. float, glass, and these can present certain 5
problems in that if they are not accurately aligned, the appearance of the building is marred by the
different reflections from the different panels. Furthermore, in the case of sealed hollow glazing panels,
the quantity of air or gas within the panels obviously remains constant, so that as a result of variations in
10 temperature or atmospheric pressure the sheets of the panels may become curved, e.g. dished, and this 10
again will mar the appearance of reflections from the building.

It is an object of the present invention to provide a glazing panel in which these disadvantages are
mitigated and in which an additional decorative effect is achieved.

According to the present invention, there is provided a hollow light-transmitting glazing panel
characterised in that it comprises a figured glazing sheet and at least one other glazing sheet and in that
15 at least one face of such figured sheet bears a coating adapted to enhance the reflectivity of the coated 15
sheet face in respect of visible light radiation.

When such a panel is viewed in light reflected therefrom it can present a highly decorate spangled
or sparkling effect. Because of this spangling or sparkling, panar reflection over the whole panel area is
masked, and accordingly, accurate alignment of adjacent panels in a curtain wall of a building is no
20 longer so critical. Furthermore, when the panel comprises a sealed hollow unit formed by a flat glazing 20
sheet and said figured sheet, as it does in preferred embodiments of the invention, any dishing of the
sheets of the panel due to differences in pressure as between its interior space and the exterior will also
be masked, at least in part.

The invention is not limited to the use of such panels in external building walls. The panels may
25 equally be used in interior partitions. 25

The sheet or sheets of the panel may be made of any desired glazing material, for example glass,
vitro-crystalline material or plastics material such as a polycarbonate or polymethylmethacrylate. Glass
is however the preferred material.

A panel according to the invention will in general exhibit a spangled or sparkling effect when viewed
30 from either side, but this effect will, in most embodiments of the invention be greater when the panel is 30
viewed from one side rather than the other. This difference in effect is minimised when each glazing
sheet is of clear glazing material as it is in some preferred embodiments of the invention. When the
panel is used in an exterior wall, that one side which exhibits greater spangling will normally be
intended to face the exterior so that the greater spangling effect is observable by passers-by rather than
35 by occupants of the building. Of course if it is desired, the panel may be mounted in the reverse sense. 35

In order further to increase the difference in the spangling effects observable from the two sides
of the panel, should this be desired, some preferred embodiments of the invention provide that the or a
said other glazing sheet is a sheet of tinted glazing material. Of course the tinted glazing material should
be between the figured sheet and the observer when the panel is installed for the spangling effect to be
40 reduced. The use of tinted glazing material has other important advantages, among which may be cited 40
its relatively low radiant energy transmission properties as compared with clear glazing material. This
can be very important for the comfort of occupants of a building in which the panel is installed.

Indeed when tinted glazing material is used to form the or a said other glazing sheet, the
advantages of the present invention are not so dependent on the siting of the reflective layer, and
45 accordingly, in its second aspect, the invention provides a hollow light-transmitting glazing panel, 45
characterised in that it comprises a figured glazing sheet and at least one other glazing sheet which is
formed of tinted glazing material and further characterised in that at least one sheet face of the panel
bears a coating adapted to enhance the reflectivity of the coated sheet face in respect of visible light
radiation. Such a panel also has the advantages of at least partially masking slight misalignment of
50 different panels and dishing of panel sheets as referred to above, and it exhibits a spangled or sparkling 50
effect which is greater when viewed from one side than the other. The said coated sheet face of a panel
according to the second aspect of the invention is preferably a face of said figured sheet, in accordance
with the first aspect of the invention.

The tinted glazing material when used in embodiments of either aspect of the invention may be
55 glass and is preferably gray glass having a purity of colour excitation of at most 6% viewed in 55
transmission. Suitable compositions of such a glass are disclosed and claimed in pending British Patent
application No. 81 06 514 filed 2nd March 1981 in the name of BFG Glassgroup (Publication No. GB
).

In fact certain of the reflective coating compositions particularly in view themselves impart a
60 coloration to the panel when it is viewed in transmission. The tinted glazing material used may be 60
selected so that its visible light transmission spectrum is such that it has a modifying effect on the
dominant wavelength or purity of colour excitation of light transmitted by the panel. For example the
tinted glazing material may be selected so that it modifies the dominant wavelength and/or enhances
the purity of colour excitation so as to achieve a desired decorative effect. Alternatively, the tinted

glazing material may be such that its visible light transmission spectrum is complementary to that of the reflective coating so that the coloration imparted to the panel by the reflective coating is reduced.

The tinted sheet suitably has a factor of luminance between 45% and 60%.

Reference in this specification, including references in its claims, to coloration and luminance properties of tinted glass and panels including a tinted glass sheet are references to such properties measured as specified in BFG Glassgroup's said application No. 81 06 514. 5

The coated sheet face is preferably interior of a said hollow unit, so that it is protected from abrasion and dirt, and also from atmospheric pollution if the unit is sealed as is preferred, any of which would cause its reflectivity to diminish over the course of time.

The figured sheet may of course be figured on both sides, but it is preferably figured on one of its faces. The figures glass may be made in the usual way, that is, by rolling a hot sheet or ribbon between steel rollers of which one has a smooth surface and the other has a figured surface. In fact when figured glass is made in this way, that surface which was in contact with the smooth roller will itself exhibit a slight counter-figuring, but this will be less pronounced than the figuring on the other surface. In this specification, that smoother surface will occasionally be denoted by the expression "the non-figured surface" while the other surface will be referred to as "the figured surface". 10 15

Advantageously, the figured surface of said figured sheet is interior of a said hollow unit. This protects the figured surface from dirt. A figured surface is much more apt to collect dirt than an unfigured surface and is also more difficult to clean.

The spangling or sparkling effect is enhanced when the figured surface of the figured sheet bears said coating as is preferred. 20

The figuring may take any desired form, for example the figuring may be such as to impart to the sheet a multiplicity of generally planar facets, but it is preferred that such figuring comprises a plurality of discrete figures each having a curved, preferably circular or elliptical, periphery and alternatively or in addition that each should have a curved sectional outline in any plane generally normal to the figured sheet. The adoption of these features allows the spangling effect to be observed from a wider location and makes the position of the sun relative to the wall in which the panel is installed of less importance for determining such location. 25

The figuring preferably comprises a plurality of discrete figures disposed on the figured sheet in a substantially regular pattern, and the figuring preferably consists of a plurality of substantially identical discrete figures. Each of these features contributes to the regularity and uniformity of the spangling or sparkling effect when a wall of such panels is considered as a whole. The discrete figures may for example be spaced on 2 to 10 cm centres. 30

The figures sheet preferably comprises a flat selvedge so as to facilitate framing. Such a selvedge may be formed by avoiding figuring of one or more edges of the panel. If the ribbon width is appropriate to the size of figured sheets to be cut therefrom, side margins of the ribbon may be left unfigured to form one side or two opposite sides of the cut sheets. It will in general be more convenient to form the selvedge by grinding away the figuring along the sheet margins. This is particularly of interest when the figured surface is to be placed to the interior of a hollow glazing panel. In such a case the space frame of the glazing panel will be fixed to the selvedge by it by soldering or by glueing to ensure that a better tightness of the glazing is achieved. 35 40

The reflective coating may be of any suitable composition, but it preferably comprises at least one metal layer. Gold is an especially suitable metal for forming reflective layers and such layers are preferably between 7 nm and 30 nm thickness. 45

In order to improve its adherence to the coated sheet, such a gold layer may be provided with a subbing layer of metal oxide, preferably bismuth oxide. 45

Another metal especially suitable for forming a reflective layer of a said coating is silver, preferably between 15 nm and 30 nm in thickness.

A said silver layer is preferably provided with a protective overcoating, suitably of nickel and/or chromium, and may be provided with a subbing layer of nickel and/or chromium. 50

Advantageously, the or at least one layer of said reflective coating is applied by a vacuum deposition technique, preferably by cathode sputtering. This is a very convenient way of applying a said coating to the required thickness.

The invention will now be described in greater detail with reference to the accompanying diagrammatic drawings in which: 55

Figures 1 and 2 are respectively sectional and plan views of a figured glazing sheet suitable for incorporation into an embodiment of panel according to the invention;

Figures 3 and 4 are similar views of a sheet having another pattern of figuring, and

Figures 5 to 7 are detail cross sectional views of three embodiments of hollow panel unit according to the invention. 60

In Figure 1, a sheet of glazing material 1 is provided with a figured surface 2 comprising a plurality of discrete figures 3 of which two and part of a third are shown. It will be noted that the figuring 3 on the upper surface 2 of the glazing sheet 1 is matched by counterfiguring on the lower surface 4 of the sheet. This is a usual consequence of figuring a sheet of glazing material. This counterfiguring is however less well defined than the figuring 3, and for the purposes of this specification, the 65

counterfigured surface is not considered to be figured.

The margin of the sheet 1 has a flat selvedge 5 ground in its lower surface 4 to facilitate sealing of the sheet 1 to a spacer member such as that indicated at 14 in Figures 5 to 7. The lower surface 4 of the sheet is provided with a reflective coating 6. In a variant of the embodiment illustrated the coating 6 is provided on the upper, figured surface 2 of the sheet. In a further variant, a rebate is ground into the upper, figured surface 2 of the sheet to provide another flat selvedge to facilitate sealing between the sheet 1 and a frame (not shown).

As will be seen in Figure 1, each of the discrete figures 3 has a sectional outline which is curved in the plane of the drawing, that is, a plane substantially normal to the plane of the sheet 1. In fact the figures 3 have a generally similar curved concave outline in any plane normal to the sheet. Such a sheet may be assembled with a sheet of flat clear glazing material, or tinted glass, to form a panel in accordance with the invention.

Figure 2 shows the sheet of Figure 1 in plan view and illustrates that the discrete figures 3 have each a curved periphery (they are in fact elliptical), and that they are arranged in a regular square or rectangular array, for example with their centres 2.5 to 3 cm apart.

In Figures 3 and 4, a glazing sheet 7 has a plurality of hexagonally arranged circular figures 8 each comprising several concentric circular ridges. Again, the sheet is provided with a flat selvedge here indicated at 9, which may be formed by grinding away figuring at the sheet margins.

Sheets with other types of figuring, for example a multi-faceted pyramidal figuring may also be used.

Such a sheet 7 may be provided on either of its faces with a reflective coating such as the coating 6 shown in Figure 1 for assembly with a sheet of flat, clear or tinted glass to form a panel in accordance with the invention, or it may be assembled together with a reflectively coated sheet of flat tinted glass to form a panel in accordance with the second aspect of the invention. The circular figures 8 may for example be spaced with their centres 7 cm apart.

A panel incorporating a figured sheet as described with reference to Figures 1 and 2 or 3 and 4 can be mounted in a wall of a building, for example as part of a curtain wall, preferably with its figured face directed to the exterior so that an observer will see the building wall as spanged. By virtue of the curved periphery of the figures 3 or 8, the visual impression given to a stationary observer will be substantially unaffected by variations in the elevation of the sun above the horizon, and by virtue of the curved sectional outline of the figures 3 or 8, such impression will also be substantially unaffected by movements of the sun across the sky.

Figures 5, 6 and 7 show three embodiments of a hollow glazing panel in accordance with the invention. Each of these Figures shows a hollow glazing panel 10 comprising a flat glazing sheet 11 bonded to a second glazing sheet 12 having a figured surface 13 by means of a spacer 14 of adhesive material leading around the margins of the panel. One sheet face of each panel 10 bears a reflective coating 15. Of course a metal spacer member could be glued or soldered to the sheet margins in place of the spacer 14 illustrated.

In Figure 5, the panel 10 is sealed within a frame 16 by bodies of mastic sealing material 17, and the figured face 13 of the figured glazing sheet 12 which also bears the reflective coating 15 is interior of the hollow panel.

In Figure 6, the reflective coating 15 is deposited on the non-figured face of the figured sheet 12 and is located interior of the panel 10.

In Figure 7, the reflective coating 15 is deposited on a face of the flat glazing sheet 11 here of tinted glass, and again is located within the panel 10.

In Figures 6 and 7, the figured face 13 of the figured sheet 12 forms an exterior face of the panel 10.

The panels 10 illustrated in Figures 5 to 7 may be installed in exterior walls of buildings with their upper sheets as shown in those drawings facing the exterior.

In a variant of the embodiment illustrated in Figure 7, the figured sheet 12 is reversed so that its figured face 13 is interior of the panel.

There now follow specific examples of reflective coatings which may be used in the performance of this invention.

Any of these coatings may be used in conjunction with a flat sheet and a figured sheet (for example as shown in Figures 1 and 2 or 3 and 4) to form a panel 10 as shown in any of Figures 5 to 7.

COATING 1

A subbing layer of Bi_2O_3 1.5 nm in thickness is applied to a vitreous sheet and is overcoated with a reflective layer of gold 19 nm thick. The subbing layer promoted adherence of the gold layer and may be applied by a vacuum evaporation technique. The gold layer may be applied by a vacuum evaporation technique. This coating gives a yellow-gold tint in reflection when viewed from the coated side of the sheet. The reflectivity of the coated sheet, measured from its coated side was 30%.

COATING 2

This coating is similar to that of coating 1 except that the gold layer is 26 nm in thickness. This

coating has a more pronounced yellow-gold colour, and gives a reflectivity of 38%.

COATING 3

5 This coating consists of a 38 nm thick subbing layer of Bi_2O_3 and a 20 nm thick gold layer. In addition to promoting adhesion of the gold layer to a vitreous sheet, the Bi_2O_3 subbing layer modifies the colour of the coating when viewed in reflection from the coated face so that it is a metallic gray colour, with a reflectivity of 36%. 5

COATING 4

10 This coating consists of a Ni-Cr subbing layer of the order of 2 nm thick, a reflective layer about 24 nm thick of silver and a protective layer again of Ni-Cr again of the order of 2 nm thick. This coating has a silvery-gray colour when viewed in reflection, its reflectivity being of the order of 49%. 10

COATINGS 5 TO 7

These coatings have the properties indicated in the following table:

	Coating 5	Coating 6	Coating 7		
15	Subbing layer Bi_2O_3	10 nm	1.5 nm	1.5 nm	
	Reflective layer Au	7.5 nm	9.3 nm	8 nm	15
	Protective layer Bi_2O_3	10 nm	—	3 nm	
	Tint in reflection	Bluish	Rose	Neutral	
	Reflectivity	13%	18%	11%	

20 There now follow specific examples of tinted glass compositions which may be used in performing the present invention. 20

TINTED GLASS 1

A tinted glass has the following composition by weight:

	SiO_2	72.9	} Glass formers		
	$\text{Na}_2\text{O} + \text{K}_2\text{O}$	13.77			
25	$\text{BaO} + \text{CaO}$	8.72			25
	MgO	3.60			
	Al_2O_3	0.72			
	Fe_2O_3	0.3700	} Colouring agents		
	Cr_2O_3	0.0185			
30	Se	0.00145			30
	Co	0.0064			
	Ni	0.0080			

35 This glass is that specified in Example 1 of BFG Glassgroup's British Patent Application No. 81 06 514 and it has the following properties when viewed in the light of C.I.E. (International Commission on Illumination) illuminant C, nominally an average daylight source with a colour temperature of 6700 K: 35

position on colour diagram:	$x = 0.3066; y = 0.3299$
luminance:	51.9%
dominant wavelength:	516 nm
purity of colour excitation:	1.3%

- 5 A sheet of this glass may be provided with a coating, for example one of coatings 5 to 7 5
exemplified above, and incorporated in a panel as illustrated in Figure 7.

TINTED GLASS 2

- 10 A tinted glass has the same glass formers as tinted glass 1 above, to which is added 0.0065% by 5
weight CoO as colouring agent. The transmission spectrum of this glass has a dominant wavelength in 10
the blue region and this may thus be considered as being to some degree complementary to the spectra 10
of coatings 1 and 2 above so that when used in conjunction with either of those coatings, the panel will
appear more neutral in transmission. Alternatively this glass may be used to enhance the bluish tint of
coating 5 above.

CLAIMS

- 15 1. A hollow light-transmitting glazing panel characterised in that it comprises a figured glazing 15
sheet and at least one other glazing sheet and in that at least one face of such figured sheet bears a
coating adapted to enhance the reflectivity of the coated sheet face in respect of visible light radiation. 15
2. A panel according to Claim 1, wherein the or a said other glazing sheet is a sheet of tinted
glazing material.
- 20 3. A hollow light-transmitting glazing panel characterised in that it comprises a figured glazing 20
sheet and at least one other glazing sheet which is formed of tinted glazing material and further
characterised in that at least one sheet face of the panel has a coating adapted to enhance the
reflectivity of the coated sheet face in respect of visible light radiation.
4. A panel according to Claim 3, wherein said coated sheet face is a face of said figured sheet.
- 25 5. A panel according to any of Claims 2 to 4, wherein said tinted glass is gray glass having a purity 25
of colour excitation of at most 6% viewed in transmission.
6. A panel according to any preceding claim, wherein said coated sheet face is interior of the
hollow unit.
- 30 7. A panel according to any preceding claim, wherein the figured surface of said figured sheet is 30
interior of the hollow unit.
8. A panel according to any preceding claim, wherein the figured surface of the figured sheet bears
said coating.
9. A panel according to any preceding claim, wherein such figuring comprises a plurality of
discrete figures each having a curved periphery.
- 35 10. A panel according to Claim 9, wherein said figures each having a curved periphery are circular 35
or elliptical.
11. A panel according to any preceding claim, wherein such figuring comprises a plurality of
discrete figures each having a curved sectional outline in any plane generally normal to the figured
sheet.
- 40 12. A panel according to any preceding claim, wherein such figuring comprises a plurality of 40
discrete figures disposed on the figured sheet in a substantially regular pattern.
13. A panel according to any preceding claim, wherein such figuring consists of a plurality of
substantially identical discrete figures.
14. A panel according to any preceding claim, wherein the figured sheet comprises a flat selvedge.
- 45 15. A panel according to any preceding claim, wherein each said glazing sheet is of glass. 45
16. A panel according to any preceding claim, wherein said coating comprises one or more metals.
17. A panel according to Claim 16, wherein said coating comprises a gold layer, preferably
between 7 nm and 30 nm in thickness.
- 50 18. A panel according to Claim 17, wherein said gold layer is provided with a subbing layer of 50
metal oxide, preferably bismuth oxide.
19. A panel according to Claim 16, wherein said coating comprises a silver layer, preferably
between 15 nm and 30 nm thick.
20. A panel according to Claim 19, wherein said silver layer is provided with a protective
overcoating, preferably of nickel and/or chromium.
- 55 21. A panel according to any preceding claim, wherein the or at least one layer of said reflective 55
coating is applied by a vacuum deposition technique, preferably by cathode sputtering.

New claims or amendments to claims filed on 20.10.81.

Superseded claims: 4.

New or amended claims:—

4. A panel according to Claim 3, wherein said coated sheet face is a face of said tinted sheet.

Printed for Her Majesty's Stationery Office by the Courier Press, Leamington Spa, 1982. Published by the Patent Office,
25 Southampton Buildings, London, WC2A 1AY, from which copies may be obtained