

T. C. DEXTER.
PAPER PASTING MACHINE.

No. 523,331.

Patented July 24, 1894.

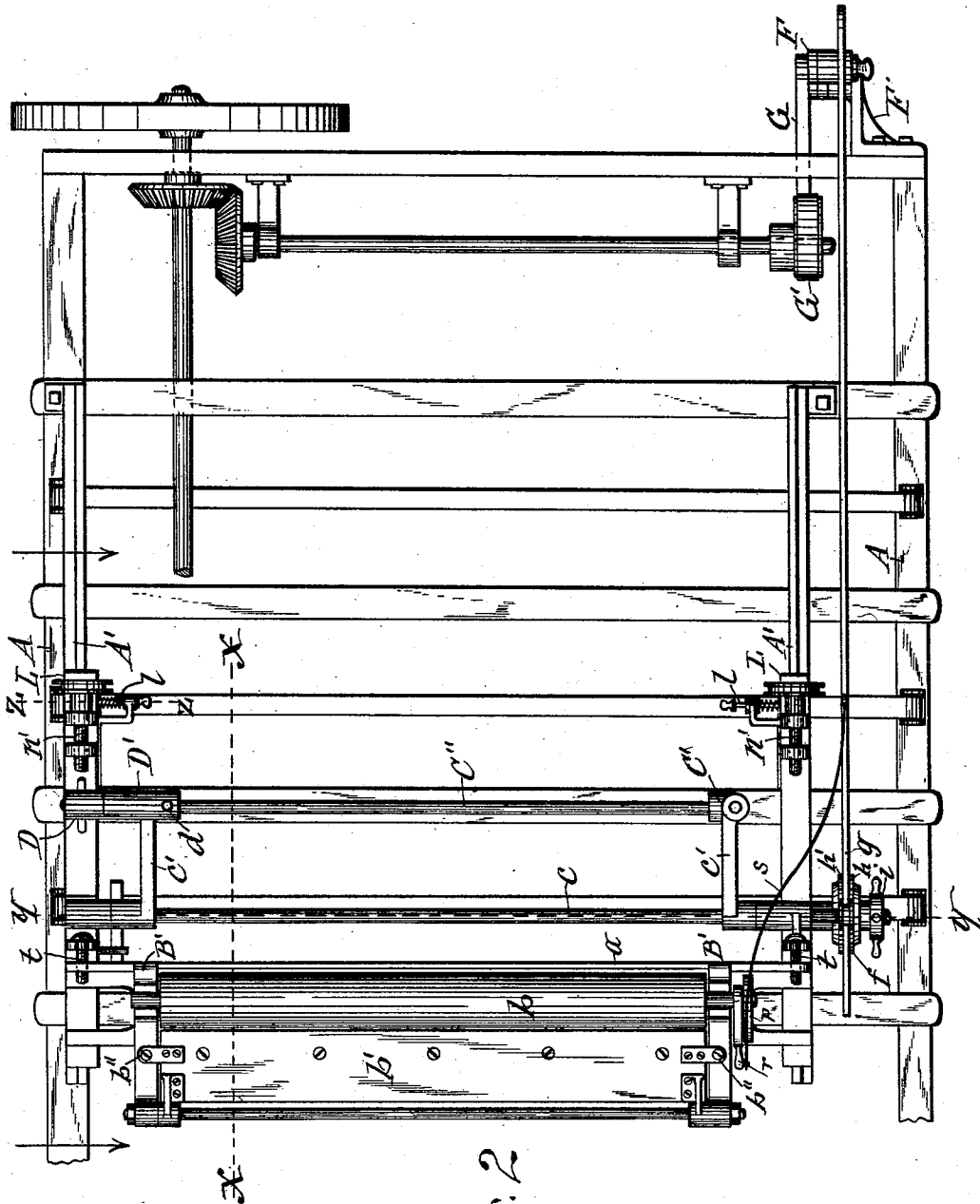

Fig. 2

WITNESSES:

C. L. Bendixon
J. J. Laass

INVENTOR:

Talbot Dexter
By C. Laass
his ATTORNEY.

T. C. DEXTER.
PAPER PASTING MACHINE.

No. 523,331.

Patented July 24, 1894.

Fig. 3

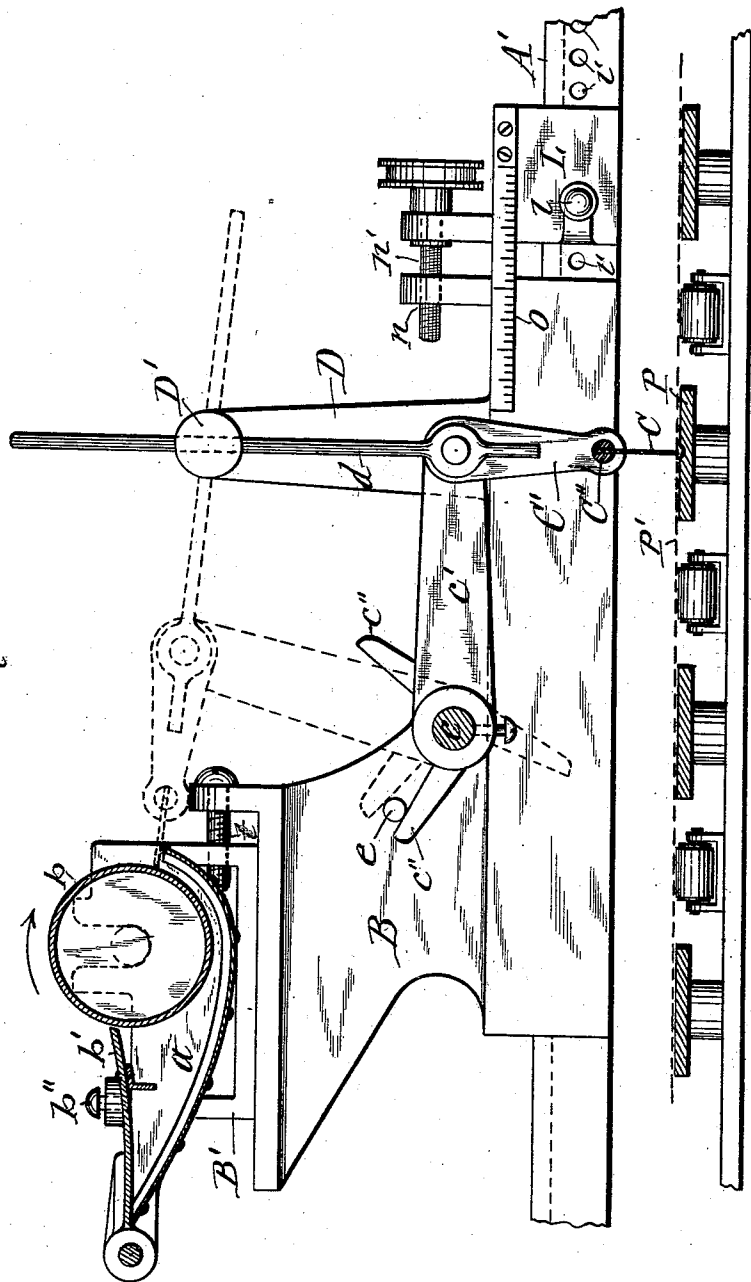

WITNESSES:

C. L. Bendixon
J. J. Laass

INVENTOR:

Talbot C. Dexter
By C. Laass
his ATTORNEY.

T. C. DEXTER.
PAPER PASTING MACHINE.

No. 523,331.

Patented July 24, 1894.

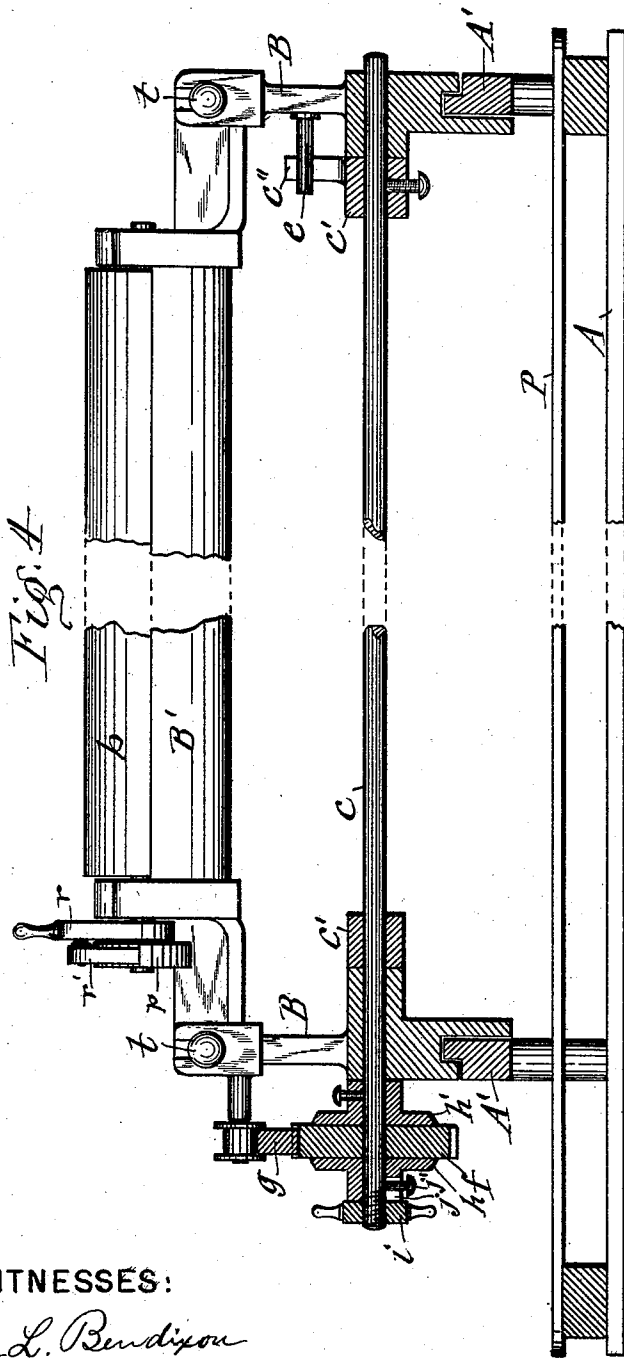

Fig. 4

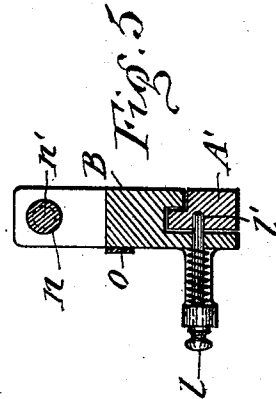

Fig. 5

WITNESSES:

C. L. Bendixon
J. J. Laass

INVENTOR
Talbot Dexter
By C. Laass
his ATTORNEY.

UNITED STATES PATENT OFFICE.

TALBOT C. DEXTER, OF FULTON, NEW YORK, ASSIGNOR TO THE DEXTER FOLDER COMPANY, OF SAME PLACE.

PAPER-PASTING MACHINE.

SPECIFICATION forming part of Letters Patent No. 523,331, dated July 24, 1894.

Application filed June 16, 1893. Serial No. 477,782. (No model.)

To all whom it may concern:

Be it known that I, TALBOT C. DEXTER, of Fulton, in the county of Oswego, in the State of New York, have invented new and useful Improvements in Paper-Pasting Machines, of which the following, taken in connection with the accompanying drawings, is a full, clear, and exact description.

This invention relates in some respects to that class of paper pasting machines, in which the pasting-blade is swung back and forth between the paste-feeder and sheet-supporting bed to supply the edge of said blade with paste and apply it to the sheet of paper resting on the aforesaid bed. And the invention consists in an improved organization of said pasting appliances and auxiliary devices connected therewith whereby a paper pasting machine of superior efficiency is obtained all as hereinafter fully described and set forth in the claims.

In the annexed drawings Figure 1, is a side elevation of the main portion of a paper pasting machine embodying my invention. Fig. 2 is a plan view of the same. Fig. 3 is an enlarged vertical longitudinal section on line X X in Fig. 2. Fig. 4 is an enlarged vertical transverse section on line Y Y in Fig. 2, and Fig. 5 is an enlarged vertical transverse section on line Z Z in Fig. 2.

Similar letters of reference indicate corresponding parts.

—A—represents the main supporting frame of the machine, and —P— denotes the sheet supporting bed to which the sheets of paper are delivered in the direction indicated by an arrow in Fig. 2 of the drawings by means of any suitable and well known paper feeding mechanism not necessary to be here shown.

The top of the frame —A— is provided with parallel longitudinal ways —A'—A'—, at opposite sides, and upon these ways is mounted the supplemental frame —B— adjustable lengthwise of said ways for the purpose hereinafter explained. Upon said supplemental frame is mounted the paste-feeder consisting of a trough —a—, and a roller —b—, extending lengthwise of said trough and journaled in the end walls thereof.

The upper portion of the roller projects above the trough, and the lower portion of the

roller is immersed in the paste, and by intermittent turning of the roller the pasted lower portion of the roller is carried above the trough. To spread the paste evenly over the surface of the roller and guard against an excessive thickness of the coat of paste thereon I hinge to the top of the rear edge of the trough the combined lid and scraper —b'—, the free edge of which is supported in the required contiguity to the periphery of the roller by means of set screws —b''—b''—, connected to the lid and bearing on the trough. Said lid thus rests by gravity in its adjusted position on the trough, and by turning the screw —b''— so as to project a greater or less distance beneath the lid, the free edge thereof is raised or lowered correspondingly to permit a thicker or thinner coat of paste to adhere to the roller —b—.

Parallel with the the paste-roller —b— is a rock-shaft —c— pivoted to the base of the supplemental frame. From this shaft extend the arms —c'—, to the free ends of which is pivotally connected the pasting blade —C— preferably by means of arms —C'—, hung loosely on the arms —c'—, and having fastened to their free ends a bar —C''—, to which the blade —C— is firmly secured as best seen in Fig. 3 of the drawings.

From the supplemental frame —B— at one side of the frame —A— rises a post —D—, to which is pivoted a block —D'— axially parallel with the pasting-roller, —b—. This block is provided with a diametric channel in which slides longitudinally a rod —d—, the lower end of which is fastened to one of the arms —C'— carrying the pasting-blade —C—.

When the machine is in motion the rock-shaft —c— causes the arms —c'—c'— to oscillate in vertical planes. In their upward movement they lift the blade —C— with them, and push the rod up and cause the same to swing with the arms —c'—c'— toward the paste-roller —b—, and turn the blade —C— into such a position as to bring its free edge in contact with the paste-roller and thus apply the paste to the said edge of the blade, as illustrated by dotted lines in Fig. 3 of the drawings.

In the reverse movement of the rock-arms

—*c'*— the rod —*d*—, turns the blade —*C*— into a vertical position and causes the pasted edge of the blade to come in contact with the sheet of paper —*P'*— resting on the sheet-supporting bed —*P*— which latter may be provided with a groove in its top and directly under the line of contact of the blade with the paper as shown in Fig. 3 of the drawings. Said groove being parallel with the blade, and guarding against undue pressure of the blade upon the paper.

In order to guard against excessive impingement of the blade —*C*—, with the roller —*b*— and paper —*P'*—, I provide one of the rock-arms —*c'*— with supplemental arms —*c''*—*c'''*—, and affix to the supplemental frame —*B*— a lug or other suitable stop —*e*—, in such a position as to cause the arms —*c''*— to strike said stop at the proper times in the approaches of the blade —*C*— to the roller —*b*— and sheet —*P'*—.

For imparting the requisite rocking motion to the shaft —*c*—, I prefer to employ a pinion —*f*— mounted on the end of said shaft, and a reciprocity rack —*g*— working in said pinion. Said rack being on a prolonged bar, one end of which is connected to one end of a lever —*F*—, which is pivoted at its opposite end to a bracket —*F'*— attached to the frame —*A*—. A rod —*G*— connected at one end to the strap of an eccentric —*G'*— and at the opposite end to the lever —*F*— imparts oscillatory motion to the latter, which in turn reciprocates the rack-bar —*g*—.

Inasmuch as the paste has to be applied to the sheets at a predetermined distance from the folding-rollers —*R*—*R*—, through which the sheets are subsequently passed, the supplemental frame —*B*— with its appurtenances has to be adjustable longitudinally on the main frame —*A*—, which adjustment is effected in the manner hereinafter described.

In order to render the action of the rock-shaft —*c*— and pinion —*f*— self adjusting during the adjustment of the supplemental frame, I mount the said pinion loosely on the rock-shaft and clamp it between two collars —*h*— and —*h'*— attached to the shaft and holding the pinion by frictional contact therewith. In placing the supplemental frame —*B*— a greater or less distance from the folding rollers —*R*— and securing in its requisite position on the frame —*A*—, the rack —*g*—, when set in motion, turns the pinion —*f*— and inasmuch as the motion of the rock-shaft —*c*— is limited by the stop —*e*— the aforesaid pinion is compelled to slip and turn on the shaft after the motion of the latter has been arrested by the aforesaid stop, thus the pinion is set into proper position on the shaft to impart the requisite motion to the same. The frictional holds of the collar —*h*—*h'*— on the pinion enabling the latter to turn the shaft between its two stopping points.

To allow the frictional holds of the collars —*h*—*h'*— to be adjusted to a greater or less force, I mount the outer collar —*h*— movable

longitudinally on the shaft, and screw-thread the adjacent end of the shaft and apply there to a nut —*i*— which bears on the exterior of the collar —*h*—. By tightening or loosening the said nut the collar is pressed with greater or less force against the side of the collar. To prevent the said loosely mounted collar from turning on the shaft, I provide the hub of said collar with a longitudinal slot —*j'*— and insert therein a set-screw —*j''*— which engages the shaft as shown in Fig. 4 of the drawings.

To allow the supplemental frame —*B*— to be accurately adjusted in its requisite position, I mount on each of the ways —*A'*—, a rider —*L*— to which is connected a spring-actuated locking-pin —*l*—, and provide the adjacent way —*A'*— with a series of sockets —*l'*— with either of which the locking-pin is adapted to engage as more clearly shown in Fig. 5 of the drawings. The adjacent portion of the supplemental frame —*B*— is provided with a screw-threaded eye —*n*—, which is parallel with the way —*A'*—, and in this eye works a screw —*n'*—, journaled on the rider and shouldered on the latter to prevent the screw from moving longitudinally thereon.

In adjusting the supplemental frame in its position, the locking-pins —*l*—*l*— are withdrawn from the sockets —*l'*—, then the aforesaid frame is slipped along toward its requisite position as near as the engagement of the locking-pins with the sockets will permit. Then the riders —*L*—*L*— are to be fastened by the locking-pins entering the sockets, and the final adjustment is effected by means of the screws —*n*'—*n'*—.

To insure a uniform adjustment at both ends of the supplemental frame, I attach to the ways —*A'*—*A'*— graduated scales —*o*—, the end-faces of the bases of the supplemental frame serving as indicators by which to determine the position of said frame. I also prefer to render the paste-feeder adjustable on the supplemental frame —*B*— by making the cross-bar —*B'*— of said frame separate from the end walls thereof and mounting the paste-trough —*a*— on said cross-bar. The cross-bar is provided in one of its sides with screw-threaded eyes or sockets in which are inserted the screws —*t*— pivoted to the end-walls of the supplemental frame. By turning said screws the cross-bar is moved back and forth as may be desired.

For turning the paste-roller —*b*— automatically, I fasten to the shaft of said roller a ratchet-wheel —*p*— and pivot to said shaft a lever —*r*— to which is connected a pawl —*r'*— engaging the ratchet-wheel. A rod —*s*— connects the lever —*r*— to the reciprocating rack —*g*— and thus receives an oscillatory motion which is transmitted to the roller —*b*— by the aforesaid pawl —*r'*— and ratchet-wheel —*p*—.

What I claim as my invention is—

1. In combination with the frame and sheet-supporting bed, a paste-feeder over said bed,

a rock-shaft parallel with said paste-feeder, arms extending from said rock-shaft, a pasting-blade pivotally connected to said arms, a post mounted on the frame, a block pivoted to said post axially parallel with the rock-shaft, a guide-channel diametrically through said block, a rod sliding in said channel and fixed to the aforesaid pasting-blade, an oscillatory driver yieldingly connected to the rock-shaft to automatically adjust itself and stops on the frame limiting the movement of the rock-shaft as set forth.

2. In combination with the frame, sheet-supporting bed and paste-roller, a rock-shaft parallel with said roller, arms extending from said shaft, a pasting-blade pivotally connected to said arms, a post on the frame, a block pivoted to the post axially parallel with the rock-shaft and provided with a diametric channel, a rod sliding in said channel and fixed to the aforesaid pasting blade, stops on the frame limiting the movement of the rock shaft, and an oscillatory driver mounted yieldingly on the rock-shaft to accommodate itself to the stops and having sufficient frictional hold to transmit motion to said rock shaft as set forth.

3. In combination with the main frame, and sheet-supporting bed, a supplemental frame mounted on the main frame adjustable longitudinally thereon, a paste-feeder mounted on the supplemental frame, a rock-shaft pivoted to the supplemental frame, and carrying the paste-blade, a pinion mounted yieldingly on said rock-shaft and held thereon by frictional bearings, stops on the frame arresting the movement of the rock-shaft and a reciprocating rack working in said pinion, as set forth.

4. In combination with the main frame and sheet-supporting bed, a supplemental frame on the main frame adjustable longitudinally, a paste-feeder mounted on the supplemental frame, a rock-shaft parallel with said feeder pivoted to the supplemental frame, a pasting-

blade carried by said rock-shaft, stops on the supplemental frame limiting the movements of the rock-shaft, a pinion mounted on the rock-shaft and held thereon by frictional bearings, and a reciprocating rack working in said pinion substantially as described and shown.

5. In combination with the main frame, parallel longitudinal ways on opposite sides of said frame and provided with a series of sockets distributed lengthwise of the ways, a supplemental frame mounted on said ways and having screw-threaded eyes parallel with the ways, riders on the ways, screws journaled on the riders and working in the aforesaid eyes, locking-pins connected to the riders and engaging the aforesaid sockets, a paste-feeder mounted on the supplemental frame, a rock-shaft pivoted to the base of said frame, and a pasting-blade carried by said rock-shaft as set forth.

6. In combination with the main frame and supplemental frame mounted thereon adjustable longitudinally, a paste-trough and roller mounted on the supplemental frame, a rock-shaft pivoted to the base of the supplemental frame, arms extending from said shaft, a pasting-blade pivotally connected to said arms, a post on the supplemental frame, a block pivoted to the post, a rod sliding longitudinally in said block and fixed to the pasting-blade stops on the supplemental frame limiting the movement of the rock-shaft, a pinion mounted on the rock-shaft, collars on said shaft clamping the pinion by frictional contact between them, and a reciprocating rack operating said pinion as set forth.

In testimony whereof I have hereunto signed my name this 1st day of June, 1893.

TALBOT C. DEXTER. [L. s.]

Witnesses:

GILES S. PIPER,
ARVIN RICE.