

(19) **DANMARK**

(10) **DK/EP 3086263 T3**



(12) **Oversættelse af
europæisk patentskrift**

Patent- og
Varemærkestyrelsen

-
- (51) Int.Cl.: **G 06 K 19/077 (2006.01)** **H 01 Q 1/22 (2006.01)** **H 01 Q 1/27 (2006.01)**
- (45) Oversættelsen bekendtgjort den: **2019-06-11**
- (80) Dato for Den Europæiske Patentmyndigheds bekendtgørelse om meddelelse af patentet: **2019-03-13**
- (86) Europæisk ansøgning nr.: **16170864.9**
- (86) Europæisk indleveringsdag: **2011-11-10**
- (87) Den europæiske ansøgnings publiceringsdag: **2016-10-26**
- (62) Stamansøgningsnr: **11782607.3**
- (84) Designerede stater: **AL AT BE BG CH CY CZ DE DK EE ES FI FR GB GR HR HU IE IS IT LI LT LU LV MC MK MT NL NO PL PT RO RS SE SI SK SM TR**
- (73) Patenthaver: **MyLaps B.V., Zuiderhoutlaan 4, 2012 PJ Haarlem, Holland**
- (72) Opfinder: **Van Rens, Bas Jan Emile, Zuiderhoutlaan 4, 2012 PJ Haarlem, Holland**
Verwoerd, Adriaan Klaas, Zuiderhoutlaan 4, 2012 PJ Haarlem, Holland
Gerritsen, Reinerus Mathijs Willie, Zuiderhoutlaan 4, 2012 PJ Haarlem, Holland
- (74) Fuldmægtig i Danmark: **Patrade A/S, Ceresbyen 75, 8000 Århus C, Danmark**
- (54) Benævnelse: **RFID-brikmontage**
- (56) Fremdragne publikationer:
EP-A2- 2 400 436
WO-A1-00/21031
US-A1- 2002 167 450
US-A1- 2007 164 866
US-A1- 2008 018 428
US-A1- 2011 233 281
US-B1- 6 542 114
US-B2- 6 569 508
US-B2- 7 948 383

DESCRIPTION

Field of the invention

[0001] The invention relates to a sports bib for use in an RFID tag assembly.

Background of the invention

[0002] Radio Frequency Identification (RFID) tags are widely used for automatic time and/or location registration systems in sporting events. Typically an RFID tag comprises a microchip combined with an antenna and is structured to allow attachment to an object to be detected. In such time registration systems every participant is provided with an RFID tag, which is removable secured to a shoe or a bib comprising a number, which is associated with the name and/or address of the participant. If a participant crosses a detection antenna an electromagnetic coupling between the tag and the antenna is established thereby allowing information exchange, e.g. an identify number associated with the tag, between the tag and a detector connected to the antenna.

[0003] Currently there is a development towards the use of so-called ultra-high frequency (UHF) tags, which use frequency in the UHF band between approximately 860 and 960 MHz. These tags are much cheaper (so that they can be used as a one-time use disposable tag), are less in weight, and can be read faster and from larger distances when compared with low frequency tags. From a logistic and organisational point of view, tags are preferably distributed together with or attached to the bib so that there is an unambiguous one-to-one relation between the tag and the bib. The bib is fixed to the shirt such that the bib is located in front of the chest of the participant.

[0004] When fixing an UHF tag to a bib certain problems occur. One problem relates to the fact that the tag is within close proximity of the body, which for the tag functions as a dielectric of relatively high dielectric constant. The proximity of the body changes the impedance of the tag antenna thereby "detuning" the tag away from its optimum working point. Due to this detuning effect, the tag may not be able to generate detectable modulated backscatter signal. The effect of detuning is further enhanced in a wet environment, e.g. wet and sweaty clothing and/or body of an athlete. This way, the signal may further deteriorate thereby increasing the risk that a participant crossing or passing a detection antenna is not or at least not correctly registered by the timing system.

[0005] In order to lift at least part of this problem, a spacer in the vicinity of the tag may be used such that at least a certain distance between the tag and the wet clothes and/or body is provided. Such spacer may have the form of a strip of lightweight foam attached to or in the vicinity of the tag. Ideally such spacer should guarantee a spacing distance of about 10 mm,

however such thickness makes such tag bib assemblies not suitable for mass distribution (by post) and storage (e.g. millions or more). Therefore, in practice, spacers are used which are thinner than the desirable optimal thickness. Hence, conventional spacers thus allow only sub-optimal performance of the tag.

[0006] US 2008/0018428 discloses a communication device that includes a radio frequency identification tag that performs a radio communication with a predetermined device. This communication device can be attached to goods or products stored in a warehouse or the like. A space adjustment unit, which comprises a space adjustment screw and a spring, is configured to adjust a space between a metal plate and the radio frequency identification tag. This makes it possible to easily and effectively control the distance and the directivity of the radio communication.

[0007] US 6,542,114 discloses a loader that can be used to load or unload a plane. The loader has a horizontal platform and has a powered scissors support for the platform which is capable of vertically raising and lowering the platform. The platform supports a pallet and the pallet in turn supports several items that each have a beacon tag on it.

[0008] US 2007/0164866 discloses a security document having a contactless chip with data masking. The security document comprises a transponder connected to an antenna, serving to remotely communicate with a reader via an electromagnetic coupling, and a passive masking element of this antenna. This masking element is capable of rendering the reading of the document impossible when the security document is closed.

[0009] A further problem associated with the use of a tag bib assembly is that the tag signal may be influenced by nearby objects. Especially when a lot of participants are crossing an antenna simultaneously, the presence of other persons in the direct proximity of the radiated signal may cause that only a very small part of the signal will be picked up by the detection antenna of the timing system. Hence, when using a tag bib assembly, it is desired that the tag signal is directed towards the detection antenna.

[0010] US Patent 7,948,383 describes an RFID tag assembly for a shoe. In particular, the tag is removed from a bib and secured to a participant's shoe prior to a race. Attaching the RFID tag to the shoe requires multiple actions of the user. Improper installation of the tag to the shoe may result in a disfunctioning or even a non-functioning tag.

[0011] Accordingly, there is a need to provide an improved tag assembly, which at least alleviates at least part of these problems. In particular, there is a need for improved tag bib assemblies, in particular UHF tag bib assemblies, which are suitable for fixing to the shirt of a participant and which are not or much less affected by the wet clothes and/or body of the participant. Further, there is a need for improved tag bib assemblies, which allow the generation of a signal, which is focussed towards the detection antenna.

Summary of the invention

[0012] It is an objective of the invention to reduce or eliminate at least one of the drawbacks known in the prior art. The invention relates to a device as claimed in claim 1.

[0013] The advantageous expandable spacer may be in the form of a thin flexible sheet or structure having thin a non-expanded state (the spacer may have a thickness of approximately less than 3 millimetres, preferably less than 2 millimetres) providing a bib tag assembly which may be easily distributed and stored; and, an expanded state, wherein the material or structure may have a desired thickness so that it functions as a spacer for eliminating or at least decreasing detuning of the tag due to the close presence of the body of the wearer of the bib tag assembly. In the expanded state, the spacer provides a desired distance between the tag and the wet shirt and/or body such that the negative influence of the wet shirt and/or body are considerably reduced.

[0014] In an embodiment said expandable spacer may comprise one or more pieces of absorbing material adapted to expand at least in one dimension in a damp and/or wet environment, preferably said absorbing material comprising pressed cellulose. In this embodiment, expansion of the spacer does not require any action of the user thereby reducing the risk of tag that does not function properly.

[0015] In an embodiment said expandable spacer may comprise one or more pieces of resilient material adapted to adjust at least one dimension in response to a change in pressure and/or an applied force. In an embodiment said non-expandable state may include said resilient material being vacuum packaged or packaged under an applied force, preferably under pressure, said expansion to said expanded state being initiated by breaking said vacuum or said pressurized package. In an embodiment said expandable spacer may comprise one or more pieces of chemically expandable material. In a further embodiment said expandable spacer may comprise at least one mechanically expandable structure. In yet a further embodiment said at least one mechanical expandable structure may be configured as a foldable structure having collapsed state and an erected state of a predetermined spacer thickness. In another embodiment said spacer may be configured as a self-erecting structure.

[0016] In an embodiment spacer in said expanded state may have a thickness in a range between 5 and 15 mm, preferably between 8 and 12 mm. In an embodiment said spacer in said non-expanded state may have a thickness smaller than 5 mm, preferably smaller than 3 mm.

[0017] In an embodiment said tag may comprise at least one metallic dipole antenna structure and wherein said spacer structure may be located within the proximity of said antenna structure and/or at least partly on top of said dipole antenna structure.

[0018] In an embodiment said tag may be operative in the ultra-high frequency range, preferably in the range between 800 and 1000 MHz

[0019] In an embodiment said support sheet may be a bib comprising a printed identifier, preferably said transmitted signal comprising an identifier associated with said printed identifier.

[0020] In a variant said support sheet may further comprise one or more metallic passive elements for directing at least part of said signal into a predetermined direction. In another variant at least one of said passive elements may be configured as a reflector, preferably the length of said reflector being larger than the length of said tag. In yet another variant at least one of said passive elements may be configured as a director, preferably the length of said director being smaller than the length of said tag. In a further variant at least one of said passive elements may be formed onto said support sheet using conductive ink or coating. The use of passive elements in combination with one or more expandable spacer structures provides a tag assembly which is capable of producing a signal which is not or at least less influenced by the direct proximity of the body and which is effectively focussed into a desired direction.

[0021] In yet a further variant said assembly may further comprise a non-expandable spacer structure disposed on said support sheet, said expandable spacer structure providing a predetermined spacing between said tag and said body when said expandable spacer structure is not in its expanded state.

[0022] In an variant said non-expandable spacer structure has a thickness between 2 mm and 6 mm.

[0023] In an variant said assembly may further comprise at least a dielectric layer disposed between said tag structure and said expandable spacer structure, wherein said dielectric layer comprises a high-dielectric material and wherein said metallic thin-film antenna structure is impedance matched to said processor taking into account the presence of said dielectric layer in the direct proximity of said antenna structure. The presence of a dielectric layer may partially "screen" the proximity of the body away from the tag so that detuning effects associated with the proximity of the body can be considerably reduced.

[0024] The invention will be further illustrated with reference to the attached drawings, which schematically will show embodiments according to the invention. It will be understood that the invention is not in any way restricted to these specific embodiments.

Brief description of the drawings

[0025]

Fig. 1A-1C schematically depict bib tag assemblies according to various embodiment of the invention;

Fig. 2A-2C depict a timing system for use with a bib tag assembly according various embodiments of the invention;

Fig. 3A-3D depict an embodiment of an expandable tag spacer for use in a bib tag assembly according to an embodiment of the invention;

Fig. 4A-4B depicts expandable tag spacers according to various embodiments of the invention;

Fig. 5A-5C depict schematics of an expandable spacer structure according to another embodiment of the invention;

Fig. 6A-6C depict schematics of an expandable spacer structure according to yet another embodiment of the invention;

Fig. 7A-7B depict schematics of an expandable spacer structure according to yet another embodiment of the invention;

Fig. 8A-8D depict schematics of an expandable spacer structure according to various other embodiments of the invention;

Fig. 9A-9C depict schematics of a bib tag assembly according to a further embodiment of the invention.

Detailed description

[0026] **Fig. 1A-1C** schematically depict bib tag assemblies according to various embodiment of the invention. In particular, **Fig. 1A** and **1B** depict the front and backside of a bib tag assembly for use e.g. in a sports event comprising a support sheet **102**, e.g. a flexible, light-weight, water-resistant, sheet-like material that is adapted to be affixed to a person through the use of an adhesive or mechanism to pin or tie the support sheet to the person or animal (or clothing on the person or animal). Exemplary materials used for support sheet include fabric, paper, woven sheet, plastic or any combination thereof. Preferably, a front side of the support sheet may display an identifier such as an identifier **104** identifying the person to which the support sheet is affixed. Support sheet **102** may have a rectangular, 4-sided shape, but in other embodiment it may have any suitable shape, e.g., shape of a logo.

[0027] **Fig. 1B** depicts the backside of the support sheet to which at least one tag **108** is affixed. In order to make the tag suitable for a sports timing system, the tag may comprise an antenna **106** for receiving and transmitting signals. In one embodiment, the tag may relate to an UHF tag operating in the UHF frequency range. In more general, the tags or tag structures described below may be configured to operate in the frequency range between 800 and 1000 MHz. In one embodiment, a tag may operate in a frequency range between 860 and 960 MHz.

in another embodiment, the tag may operate in a frequency range between 900 and 930 MHz. In yet another embodiment, a tag may operate in a frequency range between 940 and 970 MHz. The antenna associated with the tag may have a predetermined shape. The antenna may be a metallic (foldable and/or flexible) thin-film layer.

[0028] In one embodiment, the tag may have the form of a dipole antenna. The unfolded length of the tag may be approximately half the wavelength of the operation frequency, e.g. between 10-20 cm (900 MHz equals approximately 16 cm). The tag may further comprise a processor, i.e. an RFID-specific processor, for processing signals received by the tag. Tag **108** may be securely attached to support sheet **102** by means such as an adhesive or an adhesive layer. Depending on the application, the tag may be at least partly active and/or passive. In some embodiments, instead of the back-side, the tag may be affixed to the front-side of the bib.

[0029] The bib tag assembly may further comprise an expandable spacer configured to create a spacing between the tag and the wet clothing and/or body of the participant. Here, an expandable spacer refers to a spacer structure having an adjustable thickness or height or is able to have a particular range of thicknesses or heights. In one embodiment, the expandable spacer may have a collapsed/compressed state with a small thickness or height, and an expanded state with a larger thickness or height.

[0030] The spacer may have the form of one or more parts formed of expandable sheet material **110₁** located in the vicinity and/or (partly) on top of the tag/antenna structure **106,108**. The expandable spacer may be configured such that when the bib tag assembly is not in use, (e.g. assembled for distribution to participants of an event), the spacer is in a collapsed (non-expanded) state. In that case, the spacer may be in the form of a thin flexible sheet or structure attached to the backside of the bib. In the non-expanded state, the spacer may have a thickness of approximately less than 3 millimetres, preferably less than 2 millimetres. This way, a bib tag assembly may be very thin so that easy distribution by post is possible.

[0031] In contrast, when the expandable spacer is in its expanded state, the material or structure may have a desired thickness so that it functions as a spacer for eliminating or at least decreasing detuning of the tag due to the close presence of the body of the wearer of the bib tag assembly. Desired thicknesses of the expandable spacer in expanded state may be between approximately 5 and 15 mm. For an UHF tag in use, the spacer may expand to a thickness of around 10 mm. In the expanded state, the spacer provides a desired distance between the tag and the wet shirt and/or body such that the negative influence of the wet shirt and/or body are considerably reduced.

[0032] In **Fig. 1B** the tag/antenna structure may be attached to the bib such that its longitudinal axis is parallel to the ground surface. In this configuration, the tag signal may be picked up by a detection antenna, which is located on the ground (e.g. by use of an antenna mat) or above the athlete to be detected. Alternatively, as depicted in **Fig. 1C**, the tag/antenna structure **106,108** and the associated expandable spacer structure **110₂** may be attached to

the bib such that its longitudinal axis is perpendicular to the ground surface. In that configuration, the tag signal may be picked up by a detection antenna, which is located at at least one side of the athlete's path of travel.

[0033] The expandable nature of the spacer may be achieved differently depending on the desired application. For example, the expansion may be achieved by a material that expands in volume to a desired thickness. In another example, the spacer may be enabled by a mechanical structure that expands in size or enforces a certain distance/space between the bib and the body of the user wearing the bib when the structure is in its expanded state.

[0034] The expandable spacer may expand in a self-acting manner which does not require no user interaction/configuration or in a manner that requires only little user action/configuration. Moreover, the expandable spacer is configured to expand to a desired height or thickness without the risk of improper expansion of the spacer due to human errors. During shipping, the spacer preferably has collapsed state (i.e., reduced thickness) such that shipping large quantities of the bibs is practical. After shipping, the spacer may expand before the bib is attached to clothing/body, or during the use of the bib, e.g., during a race.

[0035] A common material that is expandable is a porous material such as foam and sponge. Foam is capable of expanding in size when gas or moisture fills voids, holes or bubbles in the foam thereby enlarging the volume of the foam. An example of such foam is self-expanding foam used in insulation of homes or grow toys that expand in water. Sponge-like materials are capable of expanding in size when holes in the sponge absorbs moisture or take in air/gas.

[0036] Besides absorbing moisture to expand in size, some types of porous material expand and contract in size in response to pressure changes. A porous material that is packaged in a vacuum-sealed bag may be in a compressed form. If the vacuum-seal of the bag is broken, the porous material may expand by taking in air into the pores of the material. Various expandable spacer structures are described hereunder in more detail with reference to **Fig. 3-8**.

[0037] **Fig. 2A-2C** depict a timing system for use with a bib tag assembly **202** according various embodiments of the invention. In particular, **Fig. 2C** depicts a schematic of a top-view of a timing system, which may comprise a detection antenna **208** connected to a decoder **206**. In one embodiment, the detection antenna may be configured as an elongated antenna mat placed on the ground, in the path of travel of the athletes, wherein the antenna mat may comprise one or more antennas configured to pick up signals transmitted by the bib-tag assembly.

[0038] In another embodiment (not shown in **Fig. 2C**), the detection antenna may be located at the side or above the path of travel of the athletes. Depending on the application different antenna implementations e.g. a patch antenna, a slot antenna or a yagi antenna, may be used.

[0039] In one embodiment, the tag may be configured as a passive backscatter system wherein the tag transmits a modulated signal **204** to the detection antenna. If a participant wearing a bib tag assembly **202₁₋₅** comes in the vicinity of the detection antenna, the tag antenna may receive the modulated signal **201**, which is used to power-up the processor in the tag.

[0040] **Fig. 2A** depicts e.g. an implementation wherein a detection antenna mat **210** transmits a modulated signal **201** in a direction opposite to the direction in which the athlete wearing the bib tag is moving. **Fig. 2B** depicts a detection antenna **210** located at a side of the athlete's path of travel wherein the detection antenna transmits a modulated signal towards on side of the athlete wearing a bib tag.

[0041] In response, the tag transmits information stored in the processor back to the detection antenna on the basis of a modulating back-scattered signal **203₁**. This way, the tag may start sending out messages **203₁₋₄** comprising at least a unique ID identifying the bib. The detection antenna may pick up the transmitted messages and transfer them to the decoder, which comprises a processor for executing an algorithm **212** for determining the (split) time associated with the tag on the basis of time of detection and the signal strength of the received ID messages. The processed data may be subsequently stored in a storage **214**, e.g. a database, for further use.

[0042] As the electro-magnetical field produced by the antennas in the antenna mat is strongest above the (longitudinal) centre-line **210** of the antenna, the decoder algorithm may determine the exact passing of a tag above the centre-line of the antenna mat. Determination of the time that the tag passes the centre-line requires measuring the signal strength of multiple messages originating from a tag. It is therefore very important that optimal signal transfer between the tag and the antenna mat is achieved. This may be achieved by bib tag assembly comprising an expandable spacer, which allows expansion to a desired optimum thickness.

[0043] **Fig. 3A-3D** depict an embodiment of an expandable tag spacer for use in a bib tag assembly according to an embodiment of the invention. **Fig. 3A-3C** depict at least part of a support sheet **302** to which an expandable sheet material **304** is attached to. In this particular embodiment, the sheet material may comprise a thin sheet of water-expandable material. In one embodiment, the water-expandable material may be a pressed sponge-like material, such as pressed celluloses, which absorbs water and/or moisture **306** by using capillary action to fill small holes in the interior of the sponge material. The material may be affixed to the backside of the bib and may have the form of strip in close vicinity and/or (partly) on top of the tag as illustrated.

[0044] During use, the sweat of the athlete will be partly absorbed by the water-absorbing material so that the material will start expanding as schematically indicated in **Fig. 3A-3C**. Preferably, the expansion of the material is limited to one dimension (i.e. the z-dimension perpendicular to the x-y plane of the support sheet) in order to avoid the development of

tension in the plane of the bib. The thickness of the water-expandable material in expanded state may be selected such that the spacer has a thickness of about 10 mm, i.e. a spacer thickness which allows good coupling between the tag backscatter signal and the detection antenna in the UHF frequency range. **Fig. 3D** depicts the effect of the expansion at various stages for a pressed cellulose material. This figure clearly shows that the thickness of the material in the expanded state may be easily 5-15 times the thickness of the material in the pressed state.

[0045] It is understood that the water-expandable material is not limited to water-expandable material based on sponge-like materials such pressed celluloses, but may encompass any type of material, which provides considerable expansion in at least one dimension. In one embodiment, the water-expandable material may be biodegradable.

[0046] **Fig. 4A** depicts expandable tag spacers according to various embodiments of the invention. In particular, **Fig. 4A (A)** and **(B)** depict top view and a side view of an embodiment wherein, the spacer may comprise several pieces of expandable sheet material which may be provided onto (or fixed to) the tag structure. In this particular embodiment, the tag structure may include a processor such as an integrated circuit (IC) for receiving, processing and transmitting RFID signals **404** and the metallic thin-film antenna structure **406**, which is provided onto a flexible support sheet **402**. The processor and the metallic thin-film antenna structure may be covered with a passivation layer (not shown), e.g. a thin-film insulating layer. The backside of the support sheet may comprise an adhesive such that the tag structure may be attached as a sticker to a bib. Pieces of the expandable sheet material **408₁₋₂₃** forming an expandable spacer structure may be attached to the front side of the tag structure.

[0047] The expandable spacer structure may comprise e.g. two pieces of expandable material **408_{1,2}** provided the tag structure area comprising the antenna structures and at least one piece of expandable material **408₃** provided over the area comprising the tag processor.

[0048] **Fig. 4A (C)** depicts a side view of the tag structure wherein the expandable spacer is in its expanded state.

[0049] The layout of the spacer structure may be designed such that with a minimum amount of expandable material a reliable spacing distance between the body and the tag structure is achieved. Hence, in this embodiment, tag-structures may be provisioned with an expandable spacer structure during manufacturing of the tag structure. Alternatively, the tag structure may be provided with a expandable spacer structure in a post-processing step after manufacturing of the tag structure.

[0050] **Fig. 4A(D)** depicts a further embodiment, wherein the tag structure comprises an expandable spacer structure **410_{1,2}** (e.g. two or more pieces of water-expandable sheet material similar to the ones described with reference to **Fig. 4A (A)-(C)**) and a fixed spacer structure **412** of a predetermined thickness. The fixed spacer structure may have a thickness

of about 2-6 mm and functions as a spacer structure for the time that the expandable structure has not expanded to its full height (e.g. at the beginning/start of the race when the athletes are not yet sufficiently sweating in order to activate that expandable spacer structures.

[0051] Fig. 4B (A) and (B) depict top view and side view of a tag structure according to various other embodiments of the invention. The tag structure may comprise a processor 404 and a metallic thin-film antenna structure 406 provided onto a flexible support sheet 402. The processor and the metallic thin-film antenna structure may be protected by a (thin-film) passivation layer. An expandable spacer structure 414 is disposed onto at least part of the antenna and processor area of the tag structure.

[0052] In these embodiments, the expandable spacer structure may have a multilayered structure comprising at least an expandable sheet material 408 and one or more dielectric layers 416. Fig. 4B (B) depicts a side-view of an expandable spacer structure comprising an expandable sheet material 408 and at least one layer of a dielectric having a relatively high dielectric constant 416. In this particular example, the antenna structure of the tag may be impedance matched (i.e. tuned) to the tag processor taking into account the presence of the thin film dielectric layer of relatively high dielectric constant between 10 and 50 in the direct proximity of said antenna structure.

[0053] The presence of a dielectric layer may partially "screen" the proximity of the body. In one embodiment, the layer may have a thickness of between 0.05 and 5 mm. In another embodiment the layer may comprise titanium dioxide. The layer may be formed of a polymer comprising titanium dioxide particles as a filler in order to increase the dielectric constant of the layer to a desired value.

[0054] In further embodiments (not shown), the dielectric layer 416 may comprise multiple dielectric layers, for example a first dielectric layer of a relatively low dielectric constant (e.g. between 1 and 5) at the interface with the tag structure and a second dielectric layer of a relatively high dielectric constant (between 10-50) on top of the first thin-film dielectric layer at the interface with the expandable spacer layer 408.

[0055] In one embodiment, the dielectric layers may be formed on the basis of a polymer comprising one or more dielectric fillers (e.g. titanium dioxide, silicon dioxide, aluminium dioxide, aluminosilicates, etc.) in order to form a dielectric layer of a desired dielectric constant. The dielectric constant of such layer may be controlled by controlling the composition and/or concentration of the dielectric fillers (mixture) in the polymer carrier layer.

[0056] Hence, from the above it follows that the expandable spacer for use in a bib tag provides a simple and very cost efficient way of providing a desirable distance between the body and the tag. In one embodiment, the spacer is activated when the body starts to sweat. As the water-expandable material may come in very thin flexible sheets, it does not affect the thickness of the bib tag assembly when it is stored or distributed to users. Moreover, no human intervention is needed to activate the spacer.

[0057] It is submitted that the disclosure is not limited to the examples of **Fig. 4A** and **4B** but also encompasses many different layouts and (multi-layered structures). For example, the layered expandable spacer structures described with reference to **Fig. 4B** may be implemented in accordance with one of the possible layouts as described with reference to **Fig. 4A**.

[0058] **Fig. 5A-5C** depict schematics of an expandable spacer structure according to another embodiment of the invention. Support sheet **514** is shown in **FIG. 5A-5C** with an expandable spacer having several parts. The spacer has cover **524** (or wrapping material) that is adapted to vacuum-seal and compress expandable material **522**. While cover **524** maintains a vacuum-sealed state, expandable material **522** is in a compressed state having a reduced height/thickness. The compressed state facilitates shipping and storage of said assembly. Vacuum-seal cover **516** may be a tape-like material that adheres (e.g., removably attached) to cover **524** to keep hole **520** sealed (see **FIG. 5B**). When the vacuum-seal cover is removed from cover **524**, hole **520** is exposed thus breaking the vacuum seal (see **FIG. 5C**) so that the material expands to its expanded state. The thickness of the expandable material may be selected such that the spacer has a thickness in a range between 5 and 15 mm.

[0059] Vacuum-seal cover **516** may be part of a top sheet **512**. Alternatively, vacuum-seal cover **516** may be securely attached to top sheet **512**. In embodiments where a top sheet is used, when top sheet **512** (and vacuum-seal cover **516**) is pulled away from support sheet **514**, hole **520** is exposed thus breaking the vacuum-seal. Top sheet **512** may be joined with support sheet **514** at an edge. Alternatively, top sheet **512** may be a portion of a folded support sheet **514**.

[0060] The backside of the expandable spacer structure may comprise an adhesive such that it may be fixed to the backside of a bib like a sticker. A bib tag assembly as e.g. described with reference to **Fig. 1** may be provided with such expandable spacer structure. When affixing the bib tag assembly to a shirt, the user only needs to break the vacuum-seal in order to bring the spacer structure into its expanded state.

[0061] **Fig. 6A-6C** depict schematics of an expandable spacer structure according to yet another embodiment of the invention. In this particular embodiment, a cover providing pressure onto an expandable material (resulting in a compressed state of the expandable material) is removed or opened such that pressure would no longer be applied to the expandable material. When the pressure is no longer applied, the expandable material expands to the desired thickness in order to function as a spacer for a bib tag assembly. Exemplary compression means is shown as cover **608** having at least two portions **604**, **606** that enables cover **608** to firmly and tightly compress expandable material **610**, e.g. a foam sheet, to supporting sheet **602**. Cover **608** firmly applies pressure to expandable material **610** and may be removably attached to support sheet **602** at portion **604** and/or **606**. When cover **608** is removed or opened, the compressed material expands in thickness/height to serve as a spacer, as seen in **Fig. 6C**.

[0062] The backside of the expandable spacer structure may comprise an adhesive such that it may be fixed to the backside of a bib like a sticker. A bib tag assembly as e.g. described with reference to **Fig. 1** may be provided with such expandable spacer structure. When affixing the bib tag assembly to a shirt, the user only needs to remove the cover in order to bring the spacer structure into its expanded state.

[0063] **Fig. 7A-7B** depict schematics of an expandable spacer structure according to yet another embodiment of the invention. In this particular embodiment, mechanical means for an expandable spacer may be used to create the desired space between the support sheet (as well as the tag) and the body. In **Fig. 7A** and **7C**, one side of carton **704** is used as a spacer, and said carton is firmly affixed to supporting sheet **702**. When end portions are lifted and folded to create a tube-like shape, carton **704** is transformed from a flat carton to a spacer that has expanded in space. Said carton is preferably made of a semi-rigid material that is capable of holding shape and structure in its expanded form. An alternative embodiment is shown in **Fig. 7B** (compressed state) and **Fig. 7D** (expanded state), where spacer comprises expandable portion **708** and fixed portion **706**, where fixed portion **706** is firmly affixed to supporting sheet **702**.

[0064] **Fig. 8A-8D** depict schematics of an expandable spacer structure according to various other embodiments of the invention. In this embodiment mechanically foldable structures fixed to a support sheet **802**, e.g. a bib, are used as expandable spacer. These spacer structures may have a folded state (**Fig. 8A** and **8C**) and an expanded state (**Fig. 8B** and **8D**). The spacer structure may comprise first and second support members **804_{1,2}** and first and second side members **806_{1,2}**, which are pivotably connected to the support members. The structure may be made of carton or another suitable material that has sufficient mechanical strength to serve as a reliable spacer in its expanded (erected) state.

[0065] In these particular embodiments, when folded the support and side members substantially parallel to the support sheet. In the embodiment depicted by **Fig. 8A** and **8B**, the spacer may be erected by a user by a pulling force F parallel to the support sheet. Due to the force, the side members are erected in a position substantially perpendicular to the support member thereby creating a desired spacing S between first and second members. A simple fixation mechanism, e.g. a latch **808**, may be used to fixate the structure so to keep the structure in its expanded (erected) state.

[0066] In a further embodiment, the folded mechanical spacer structure may be configured such that at least part of the pivotable connections between the support and side members is configured to provide a spring force **810**, forcing the spacer structure to be in its erected state. Hence, in that case, in order to keep the spacer in its folded state, a cover **812** may firmly applies pressure to the mechanically expandable spacer structure and may be removably attached to support sheet. When the cover is removed or opened, the spring force will cause the structure to go to its erected state (similar to the situation as described with reference to **Fig. 6**).

[0067] One skilled in the art would appreciate other expandable spacer structures are also envisaged. For example, in one embodiment an inflatable air pouches may also be used as a spacer. A pouch may be self-inflating or manually-inflatable by blowing air into the pouch.

[0068] **Fig. 9A-9C** depict schematics of a bib tag assembly according to further embodiments of the invention. As already explained with reference to **Fig. 2**, efficient coupling between the tag and the antenna is desired when the athlete approaches the antenna. Typically, only a small part of the signal may be picked up by the antenna. Moreover, when a lot of athletes cross the antenna close together, the presence of other athletes close to a transmitting tag may further degrade the signal. For that reason, in the embodiments of **Fig. 9A** and **9B** the tag assembly may comprise a bib **902** comprising a tag **904** and an expandable spacer structure **906₁** (this spacer structure may be implemented in accordance with one of the embodiment as described with reference to **Fig. 1-8**) and one or more passive elements **908, 910_{1,2}** for effectively focussing signals transmitted by the tag into a desired direction. As indicated in **Fig. 3C**, in certain applications the desired signal focussing direction **912** is in the direction of the antenna mat **914**, i.e. downwardly, right in front of the participant wearing the bib tag assembly.

[0069] The tag may comprise a dipole antenna of an elongated shape. The length is approximately half the wavelength of the operation frequency. By fixing the tag in a horizontal position onto the bib, the antenna signal may be read by an antenna which is positioned in front, above or under the athlete. A conductive passive element **908**, e.g. a conductive strip or wire of length L , which is longer than the (effective) length of the tag and which is positioned at a certain distance above the tag may function as a reflector. In that case, if a tag transmits a message (e.g. a backscattered modulated signal) to the antenna mat, part of the signal that is transmitted in a direction away from the antenna mat is reflected back towards the mat antenna, thereby effectively providing means for directing a larger part of the transmitted signal in a particular direction. This way the signal strength of the transmitted message is enhanced and the chance that the message is detected becomes larger.

[0070] In one embodiment the reflector may have a length L selected within a range between 100 and 300 mm, preferably 150 and 250 mm, wherein the length of the reflector is longer than the (effective) length of the tag. In another embodiment, the width W of the reflector may be within a range between approximately 1 to 25 mm. In yet another embodiment, the distance D between the reflector and the tag may be selected between 50 and 100 mm. Here the tag may be operated in the UHF range, preferably at a frequency of 865 MHz or 915 MHz.

[0071] The reflector may have the form of a conductive thin-film sheet fixed to the bib. Conductive materials may include aluminium, copper, conductive polymers and/or inks known in the art. In a further embodiment, the reflector may be in the shape of a conductive wire, which is fixed to or integrated into the bib material. In one embodiment, a conductive ink or a moist sponge material may be used to form a conductive reflector pattern onto the bib.

[0072] Using a reflector as described above, a net gain of approximately 6 dB may be

achieved. This allows an increase of the reading distance between a tag and the antenna mat of approximately 30-35%. In one embodiment, further improvement in the tag signal may be achieved using a battery-assisted tag. In that case, a very thin battery in the tag may provide power to feed the IC of the tag.

[0073] The bib-tag assembly in **Fig. 9B** comprises further passive elements **910_{1,2}** which are positioned under the tag. These conductive passive elements may be positioned substantially parallel to the tag and have a length which is smaller than the tag length. These passive elements, which are referred to as directors, may help to focus the transmitted in a downward direction. Typically, one or multiple directors may be used. The further a director is position from the tag, the short the length of the director (see e.g. **Fig. 9B** wherein director **910₂** is shorter than director **910₁**).

[0074] The bib-tag assemblies in **Fig. 9A** and **9B** may further comprise expandable spacer structures **906₂**, **906₃** onto and/or within the direct proximity of the reflector and/or director structures such that these passive structures are not or at least less negatively influenced by the direct proximity of the (wet) body of the wearer of the bib-tag assembly.

[0075] It is to be understood that any feature described in relation to any one embodiment may be used alone, or in combination with other features described, and may also be used in combination with one or more features of any other of the embodiments, or any combination of any other of the embodiments. Furthermore, equivalents and modifications not described above may also be employed without departing from the scope of the invention, which is defined in the accompanying claims.

REFERENCES CITED IN THE DESCRIPTION

This list of references cited by the applicant is for the reader's convenience only. It does not form part of the European patent document. Even though great care has been taken in compiling the references, errors or omissions cannot be excluded and the EPO disclaims all liability in this regard.

Patent documents cited in the description

- [US20080018428A](#) [0006]
- [US6542114B](#) [0007]
- [US20070164866A](#) [0008]
- [US7948383B](#) [0010]

Patentkrav

1. Startnummer (902) omfattende:

5 et understøtningsark (102, 302, 402, 514, 602, 702, 802) til understøtning af en brik (108, 904), nævnte understøtningsark (102, 302, 402, 512, 602, 702, 802) omfatter en trykt identifikator (104) på en første side; og

10 et udvideligt afstandsstykke (110, 304, 408, 410, 414, 522, 660, 804, 806, 906) anbragt på en anden side af nævnte understøtningsark (102, 302, 402, 514, 602, 702, 802), nævnte anden side er modsat nævnte første side, nævnte udvidelige afstandsstykke (110, 304, 408, 410, 414, 522, 610, 804, 806, 906) er udformet til at udvide sig fra en ikke-udvidet tilstand til en udvidet tilstand af en forudbestemt afstandstykkelse,

15 **kendetegnet ved, at** nævnte udvidelige afstandsstykke (110, 304, 408, 410, 414, 522, 610, 804, 806, 906) tilvejebringer en forudbestemt afstand mellem nævnte brik (108, 904) og en persons krop, hvor nævnte udvidelige afstandsstykke (110, 304, 408, 410, 414, 522, 610, 804, 806, 906) omfatter et eller flere stykker absorberende materiale indrettet til at

20 udvide sig, i det mindste, i en dimension i et fugtigt og/eller vådt miljø.

2. Startnummer (902) ifølge krav 1, hvor nævnte absorberende materiale omfatter sammenpresset cellulose.

25 3. Startnummer (902) ifølge krav 1 eller 2, hvor nævnte udvidelige afstandsstykke (110, 304, 408, 410, 414, 522, 610, 804, 806, 906) i nævnte udvidet tilstand har en tykkelse i intervallet 5 og 15 mm; og/eller hvor nævnte udvidelige afstandsstykke (110, 304, 408, 410, 414, 522, 610, 804, 806, 906) i nævnte ikke-udvidet tilstand har en tykkelse på mindre end 5 mm.

30

4. Startnummer (902) ifølge krav 3, hvor nævnte udvidelige afstandsstykke i nævnte udvidet tilstand har en tykkelse i et interval på mellem 8 og 12 mm; og/eller hvor nævnte afstandsstykke i den ikke-udvidet tilstand har en tykkelse på mindre end 3 mm.

35

5. Startnummer (902) ifølge et hvilket som helst af kravene 1-4, hvor nævnte startnummer omfatter nævnte brik, og nævnte brik (108, 904) omfatter mindst en metallisk dipolantennestruktur (106), og hvor nævnte afstandsstykke (110,

304, 408, 410, 414, 522, 610, 804, 806, 906) er placeret i nærheden af nævnte antennestruktur (106) og/eller i det mindste delvist oven på nævnte dipolantennestruktur (106).

- 5 6. Startnummer (902) ifølge et hvilket som helst af kravene 1-5, hvor nævnte understøtningsark (102, 302, 402, 512, 602, 702, 802) yderligere omfatter et eller flere metalliske passive elementer (908, 910) til at styre i det mindste en del af nævnte signal i en forudbestemt retning.
- 10 7. Startnummer (902) ifølge krav 6, hvor mindst et af nævnte passive elementer (908, 910) er konfigureret som en reflektor (908).
- 15 8. Startnummer (902) ifølge et hvilket som helst af kravene 1-7, hvor nævnte startnummer (902) yderligere omfatter en ikke-udvidelig afstandsstruktur (412, 706) anbragt på nævnte understøtningsark (402, 702), nævnte ikke-udvidelige afstandsstruktur tilvejebringer en forudbestemt afstand mellem nævnte brik og nævnte persons krop, når nævnte udvidelige afstandsstruktur (410, 708) ikke er i sin udvidede tilstand.
- 20 9. Startnummer (902) ifølge krav 8, hvor nævnte ikke-udvidelige afstandsstruktur (412, 706) har en tykkelse på mellem 2 mm og 6 mm.
- 25 10. Startnummer (902) ifølge et hvilket som helst af kravene 1-9, hvor nævnte startnummer omfatter nævnte brik, nævnte brik (108, 904) omfatter en processor (404) forbundet til en metallisk tyndfilmsantennestruktur (406), og nævnte udvidelige afstandsstykke (410) er anbragt i det mindste delvist over nævnte brik (108, 904).
- 30 11. Startnummer (902) ifølge krav 10, der yderligere omfatter mindst et dielektrisk lag (416) anbragt mellem nævnte brik (108, 904) og nævnte udvidelige afstandsstykke (410), hvor nævnte dielektriske lag (416) omfatter et høj-dielektrisk materiale, og hvor nævnte metalliske tyndfilmantennestruktur (406) er impedans-tilpasset til nævnte processor (404) under hensyntagen til tilstedeværelsen af nævnte dielektriske lag (416) i direkte nærhed af nævnte antennestruktur (406).

DRAWINGS

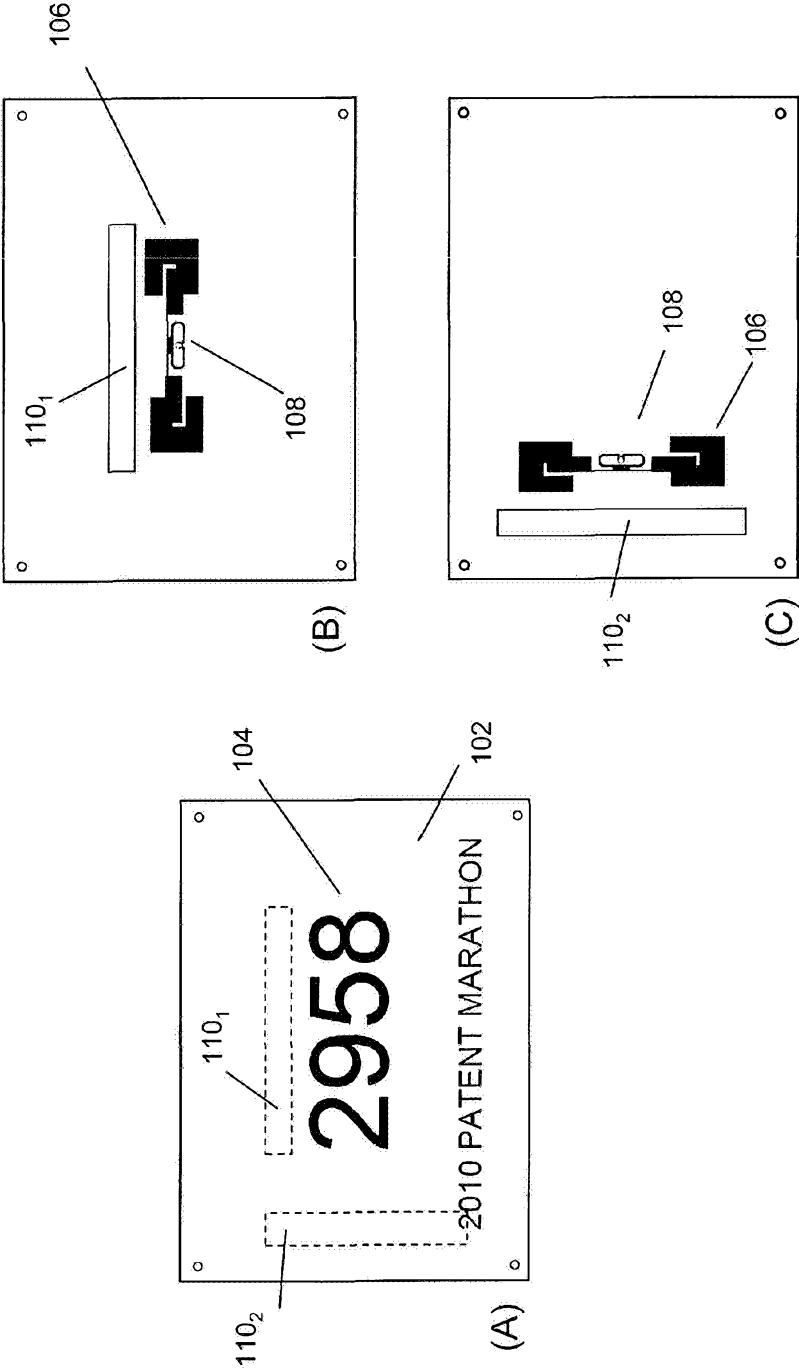

FIG. 1

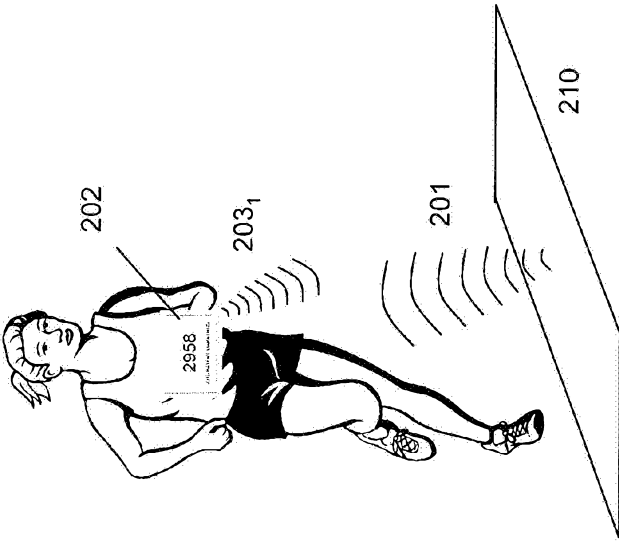

FIG. 2A

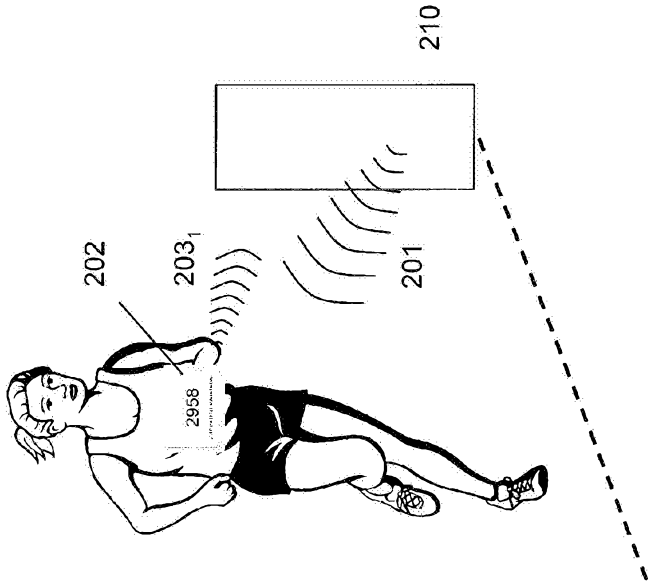

FIG. 2B

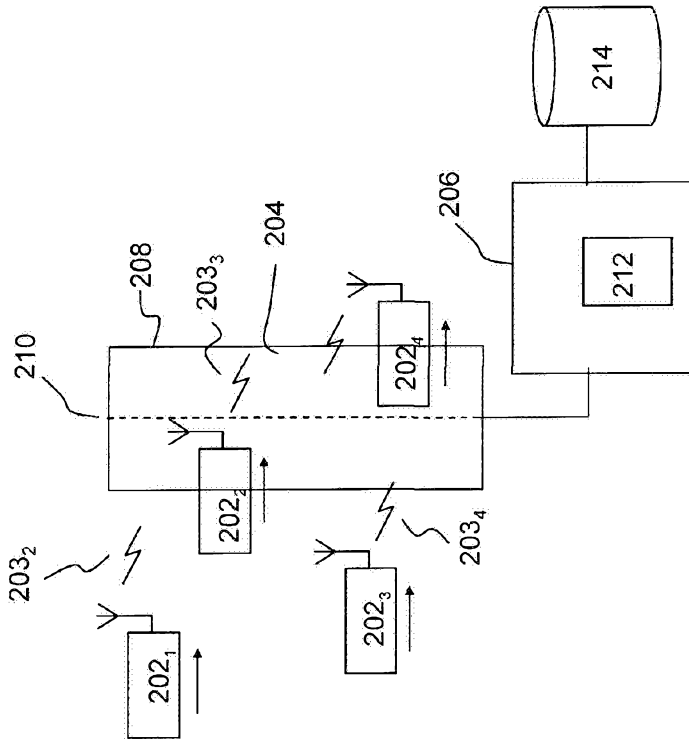

FIG. 2C

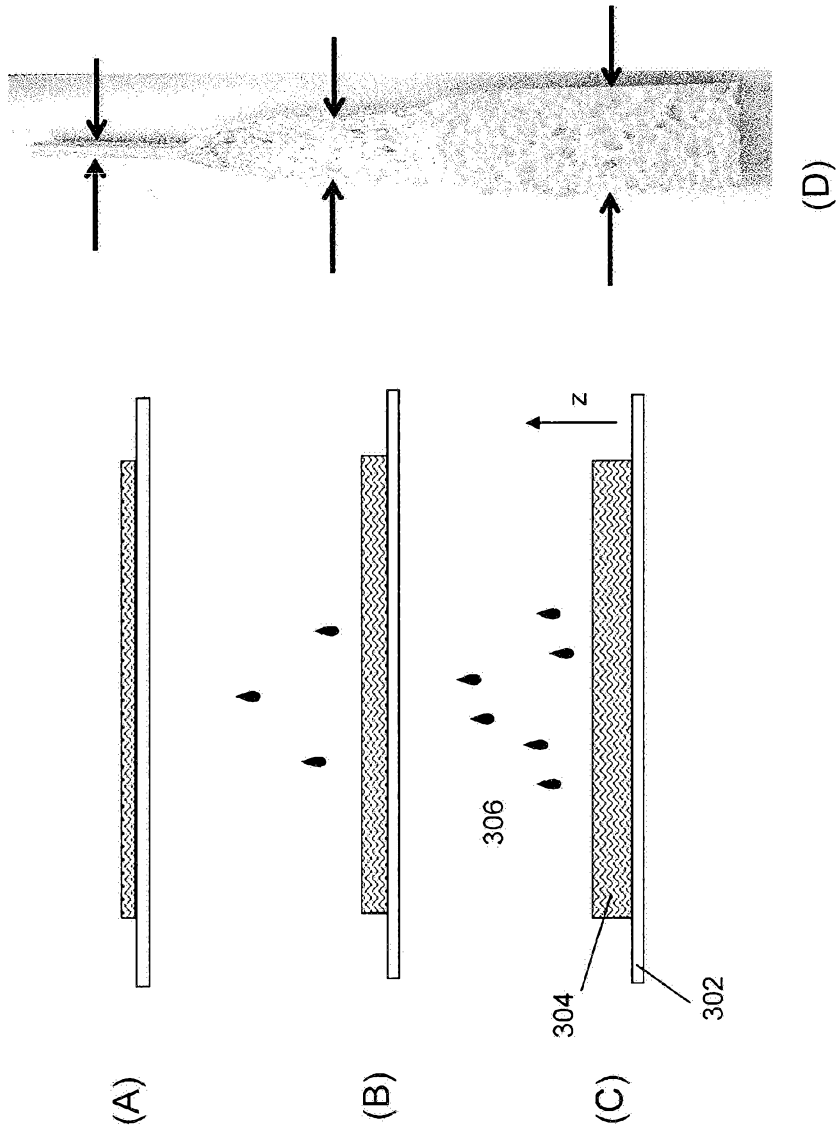

FIG. 3

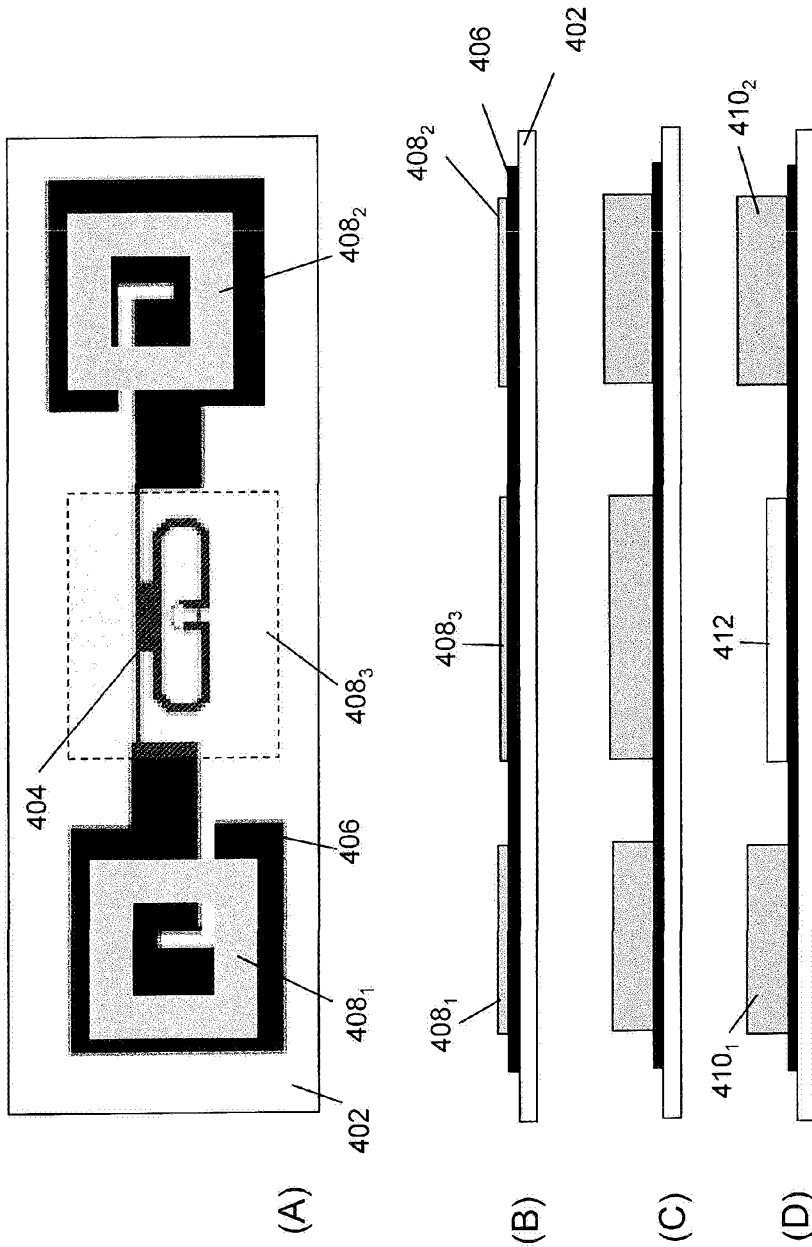

FIG. 4A

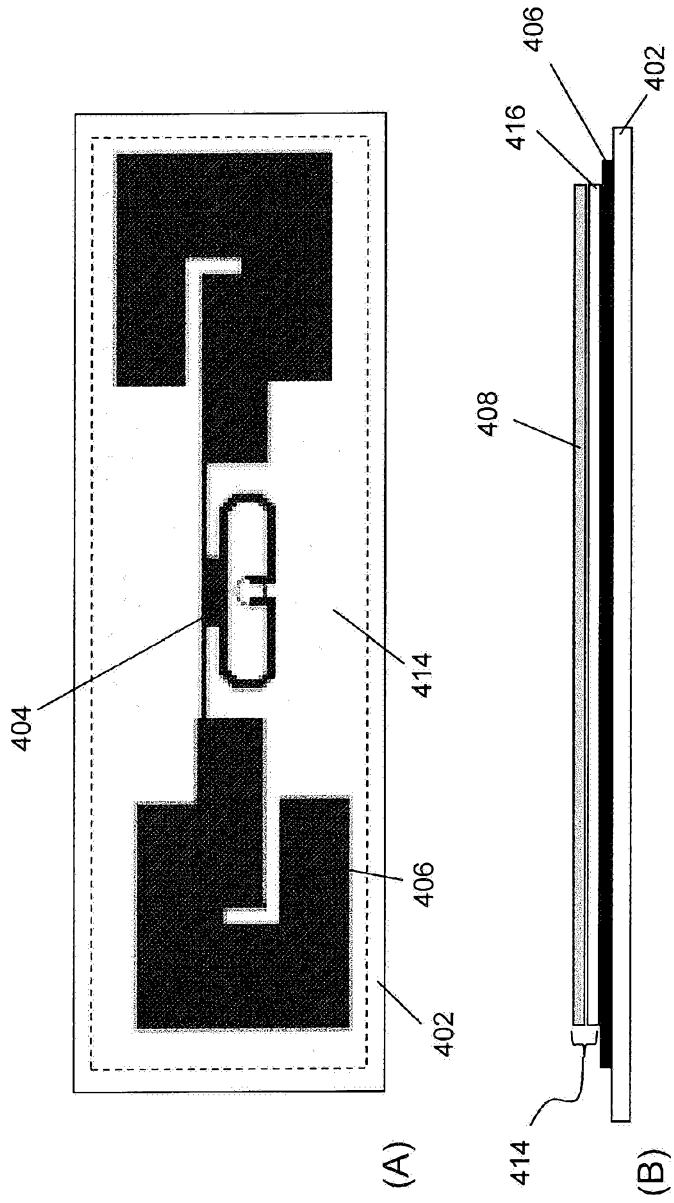

FIG. 4B

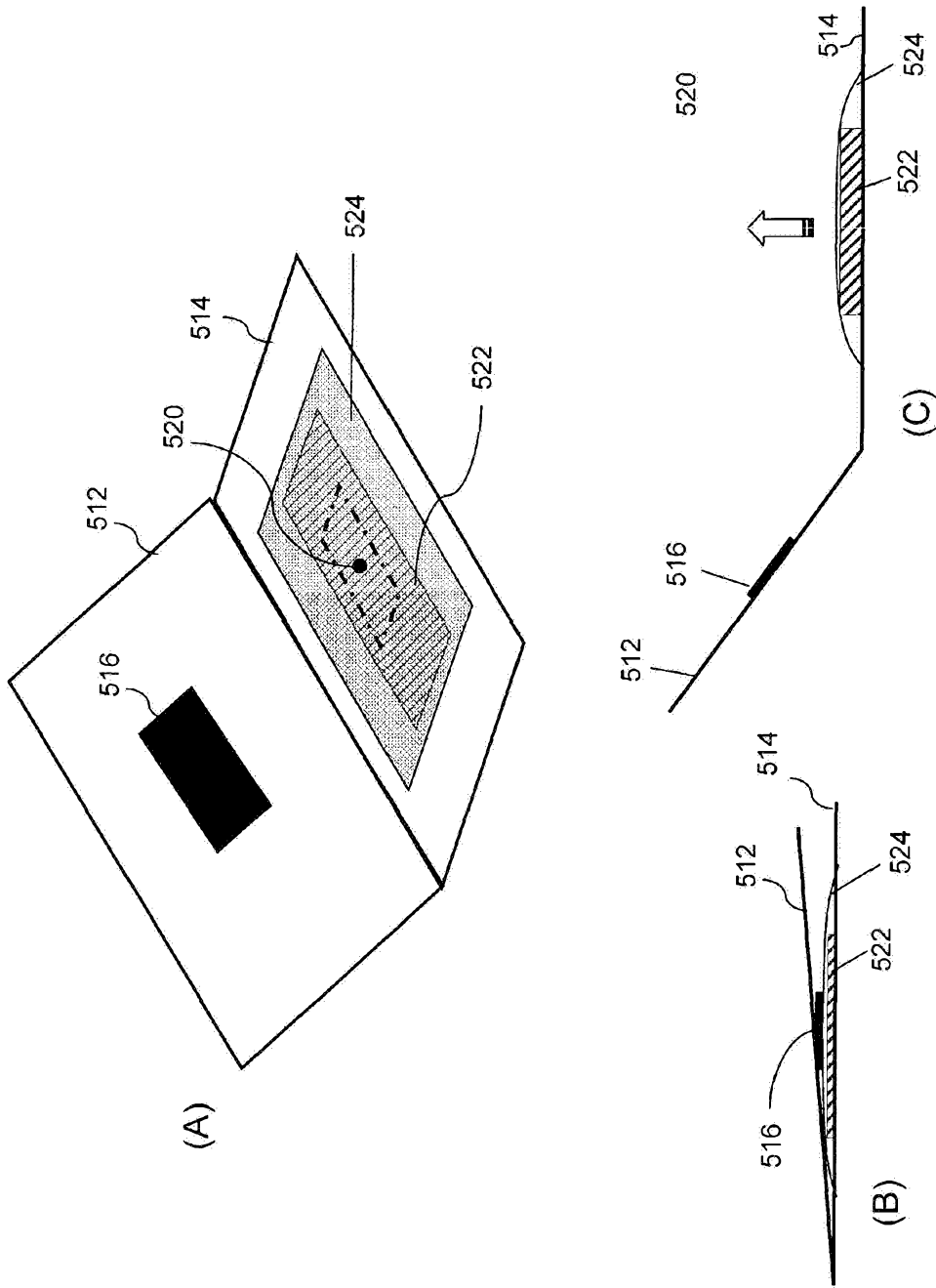

FIG. 5

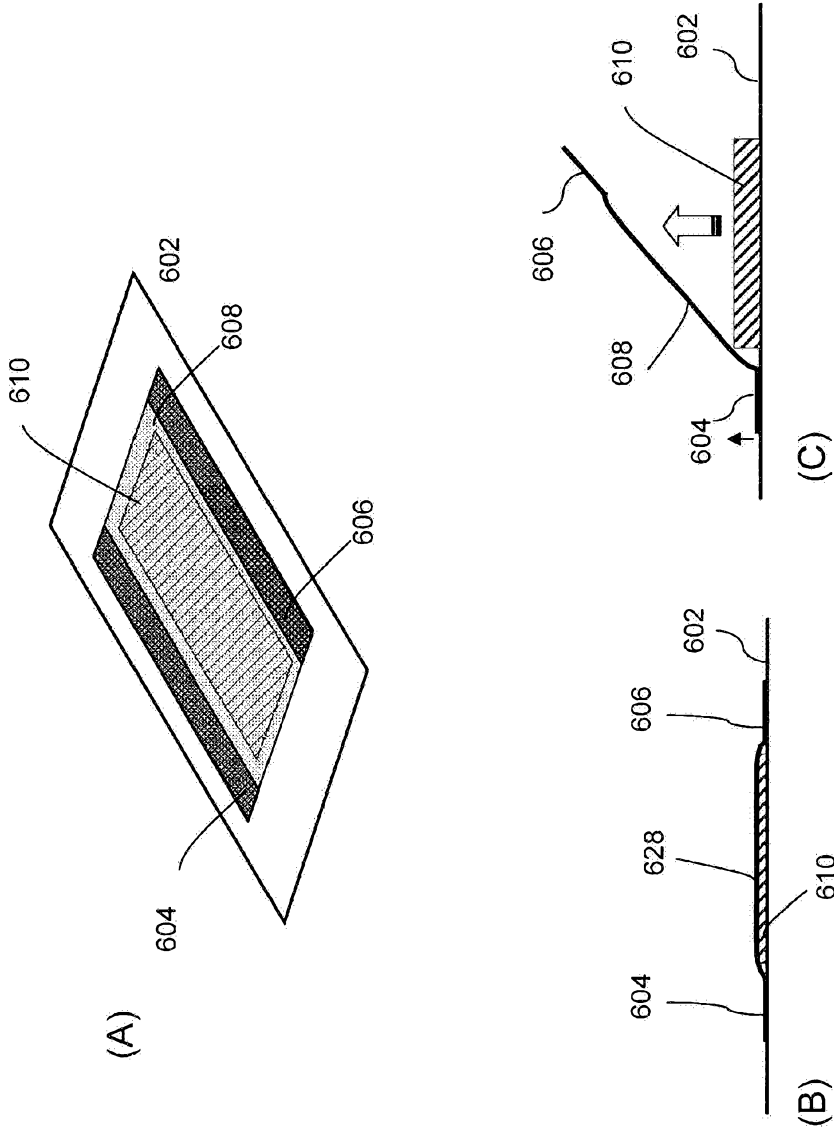
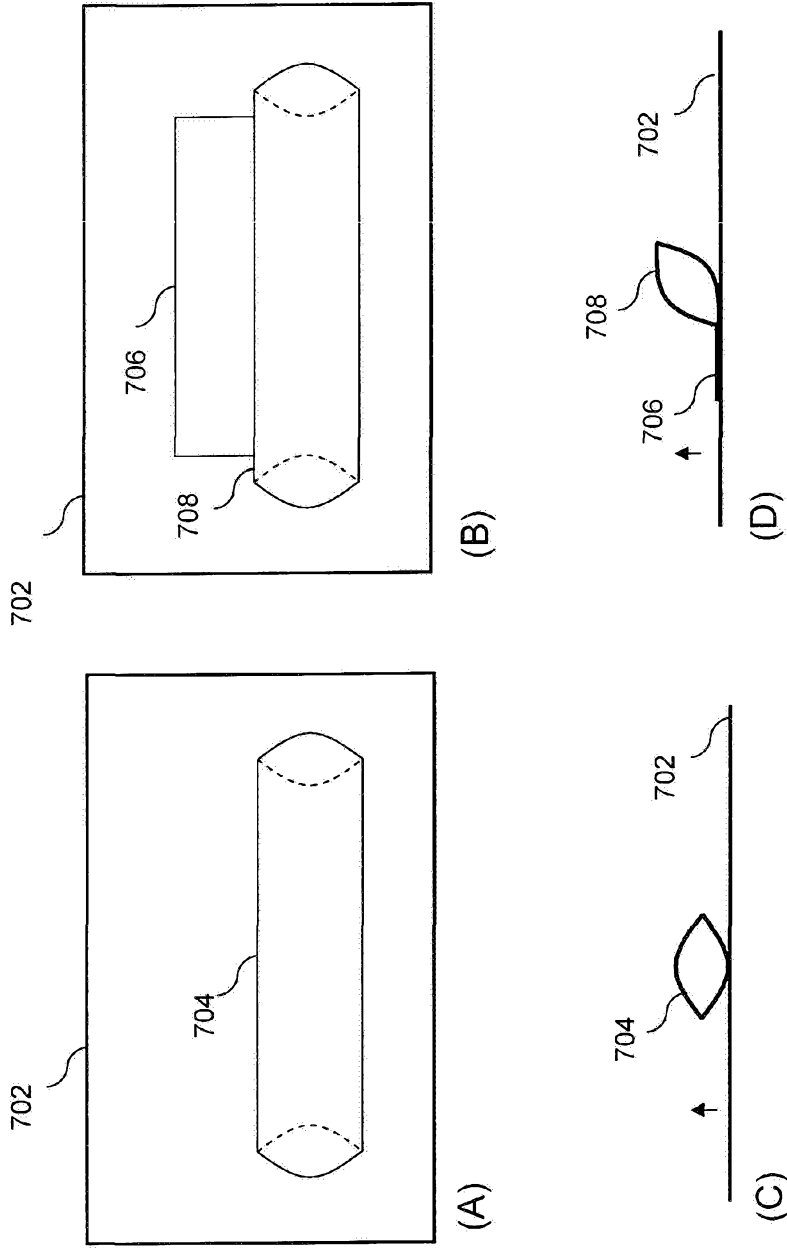

FIG. 6



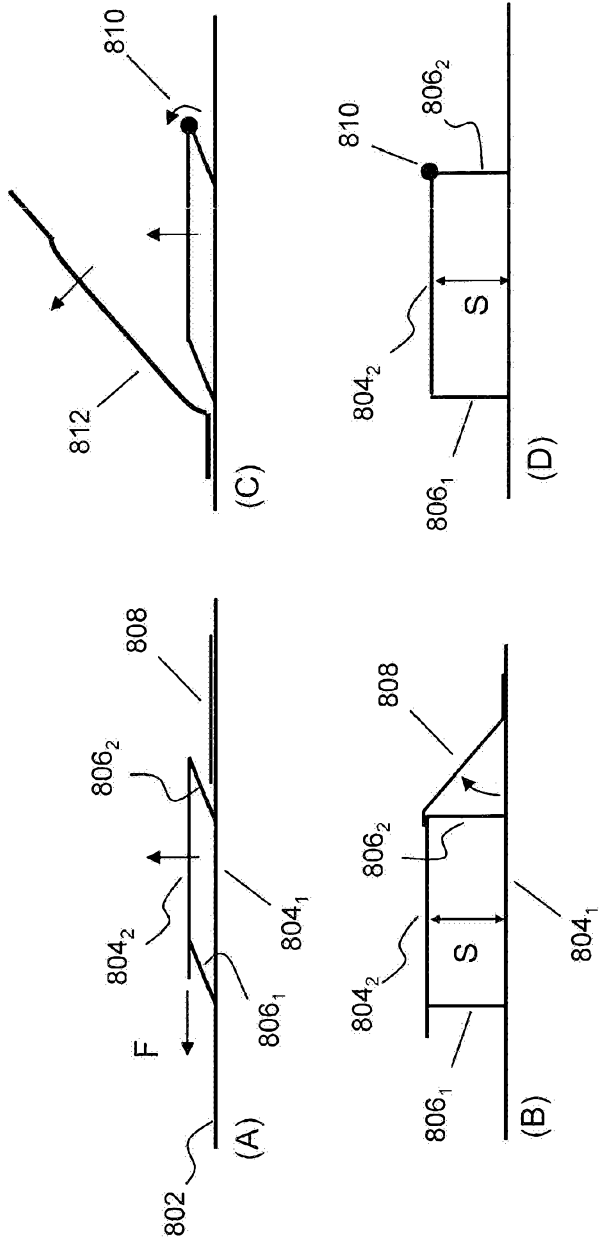

FIG. 8

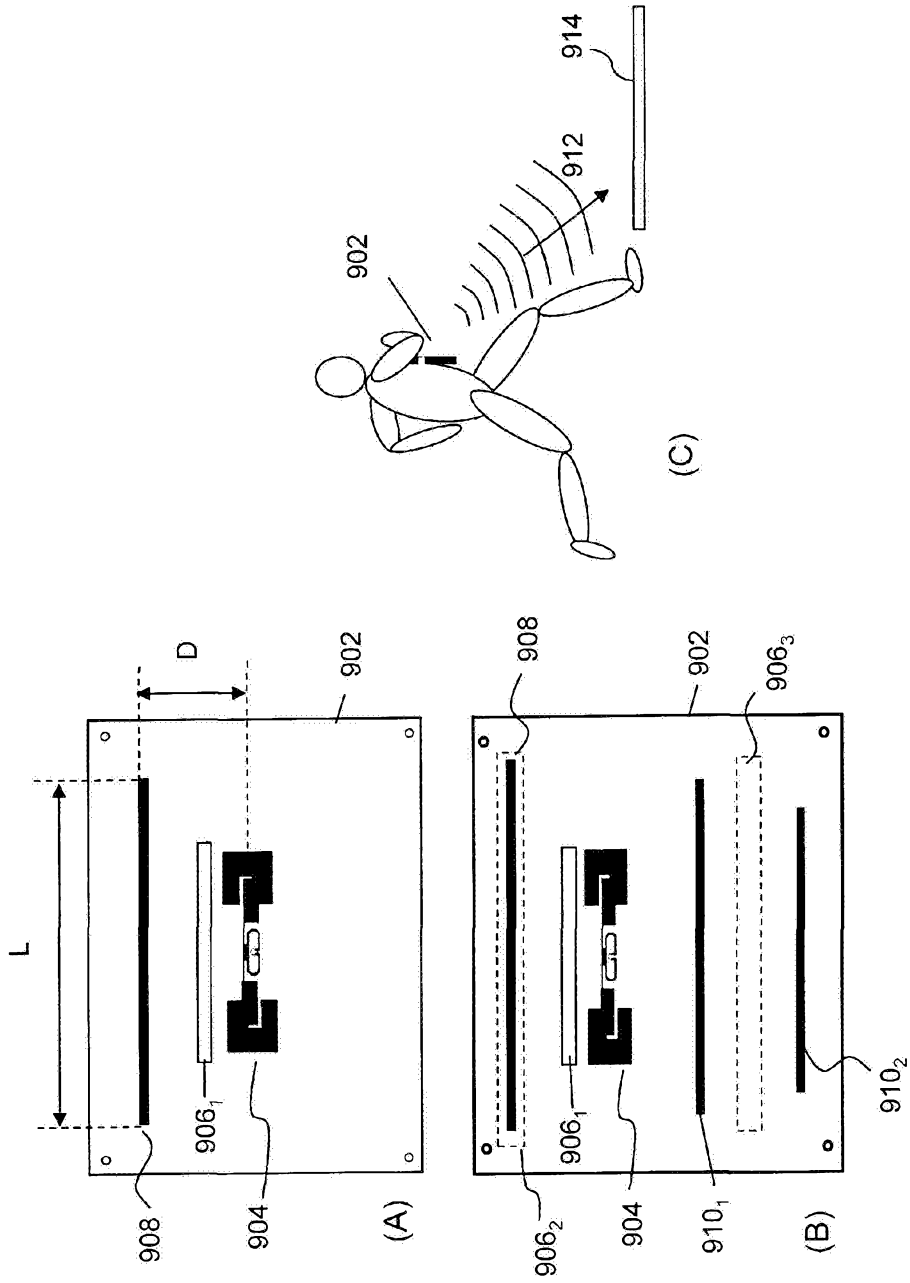

FIG. 9