



(11) **EP 1 906 429 A3**

(12) **EUROPEAN PATENT APPLICATION**

(88) Date of publication A3:  
**25.03.2009 Bulletin 2009/13**

(51) Int Cl.:  
**H01H 73/26 (2006.01)**

(43) Date of publication A2:  
**02.04.2008 Bulletin 2008/14**

(21) Application number: **07005284.0**

(22) Date of filing: **14.03.2007**

(84) Designated Contracting States:  
**AT BE BG CH CY CZ DE DK EE ES FI FR GB GR HU IE IS IT LI LT LU LV MC MT NL PL PT RO SE SI SK TR**  
 Designated Extension States:  
**AL BA HR MK RS**

(71) Applicant: **SWAIN INDUSTRY CO., LTD. Taipei (TW)**

(72) Inventor: **Chen, Tsang-I Taipei (TW)**

(74) Representative: **Strehl Schübel-Hopf & Partner Maximilianstrasse 54 80538 München (DE)**

(30) Priority: **26.09.2006 CN 200620137231 U**

(54) **Safety double-break switch**

(57) A safety double-break switch (100) is disclosed to include a housing (10), which has a button (14) pivoted to the main body (11) thereof, and a first circuit breaking mechanism (20) and a second circuit breaking mechanism (30) respectively mounted in first and second accommodation chambers (112, 113) in the housing (10) and respectively connected to external power source. When biasing the button (14) to ON position, the first

circuit breaking mechanism (20) and the second circuit breaking mechanism (30) are electrically connected with the power source, thereby resulting in the current flow. When biasing the button (14) to OFF position, the first circuit breaking mechanism (20) interrupts the power source to form a first broken circuit, and the second circuit breaking mechanism (30) interrupts the power source to form a second broken circuit.

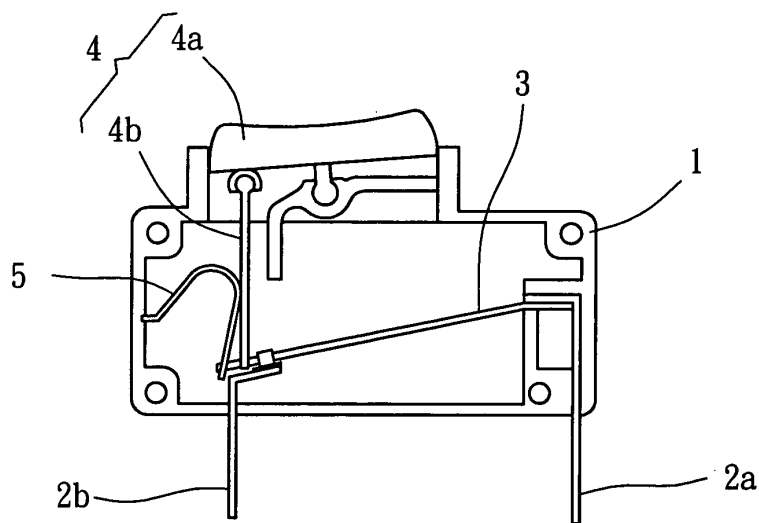

**FIG. 1**  
**PRIOR ART**

**EP 1 906 429 A3**



EUROPEAN SEARCH REPORT

Application Number  
EP 07 00 5284

DOCUMENTS CONSIDERED TO BE RELEVANT			
Category	Citation of document with indication, where appropriate, of relevant passages	Relevant to claim	CLASSIFICATION OF THE APPLICATION (IPC)
X	DE 20 2006 000010 U1 (YU TSUNG MOU [TW]) 18 May 2006 (2006-05-18) * the whole document *	1-9	INV. H01H73/26
X	DE 20 2005 018678 U1 (SUN LITE SOCKETS INDUSTRY INC [TW]) 9 February 2006 (2006-02-09) * the whole document *	1-9	
A	US 5 262 748 A (TSUNG-MOU YU [TW]) 16 November 1993 (1993-11-16) * figure 3 *		
D,A	US 2003/034871 A1 (CHENG TSANG-I [TW]) 20 February 2003 (2003-02-20) * the whole document *		
The present search report has been drawn up for all claims			TECHNICAL FIELDS SEARCHED (IPC)
			H01H
Place of search		Date of completion of the search	Examiner
The Hague		12 February 2009	Ruppert, Christopher
CATEGORY OF CITED DOCUMENTS			
X : particularly relevant if taken alone Y : particularly relevant if combined with another document of the same category A : technological background O : non-written disclosure P : intermediate document		T : theory or principle underlying the invention E : earlier patent document, but published on, or after the filing date D : document cited in the application L : document cited for other reasons ..... & : member of the same patent family, corresponding document	

2  
EPO FORM 1503 03-02 (P04C01)

**ANNEX TO THE EUROPEAN SEARCH REPORT  
ON EUROPEAN PATENT APPLICATION NO.**

EP 07 00 5284

This annex lists the patent family members relating to the patent documents cited in the above-mentioned European search report. The members are as contained in the European Patent Office EDP file on  
The European Patent Office is in no way liable for these particulars which are merely given for the purpose of information.

12-02-2009

Patent document cited in search report	Publication date	Patent family member(s)	Publication date
DE 202006000010 U1	18-05-2006	NONE	
-----			
DE 202005018678 U1	09-02-2006	NONE	
-----			
US 5262748 A	16-11-1993	NONE	
-----			
US 2003034871 A1	20-02-2003	NONE	
-----			

EPO FORM P0459

For more details about this annex : see Official Journal of the European Patent Office, No. 12/82