

(No Model.)

4 Sheets—Sheet 1.

C. HORNBERGER. APPARATUS FOR RETOUCHING NEGATIVES.

No. 522,372.

Patented July 3, 1894.

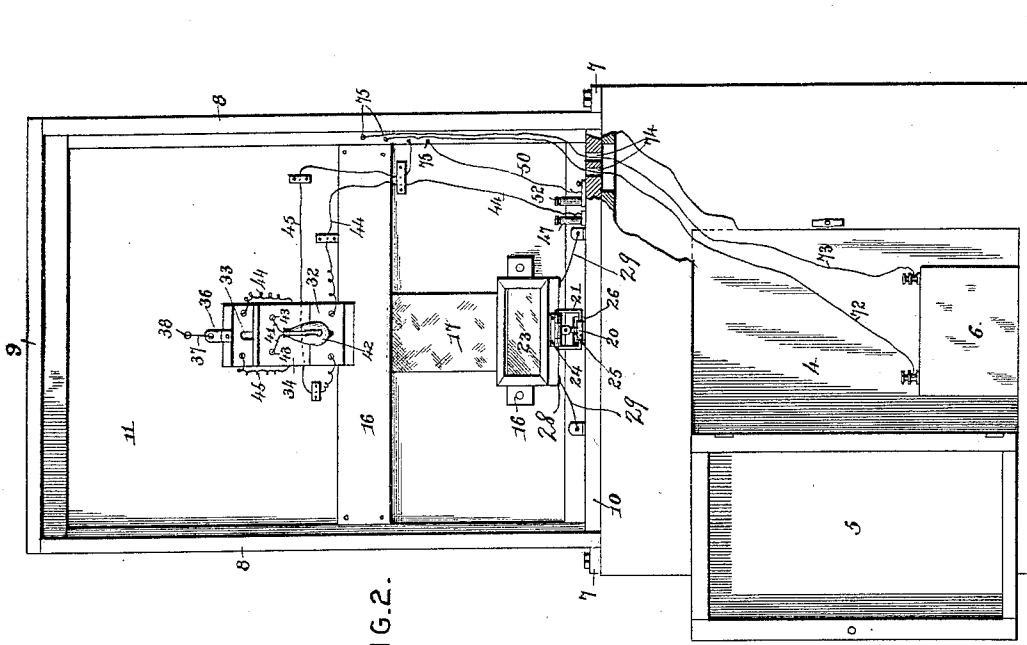

FIG. 2.

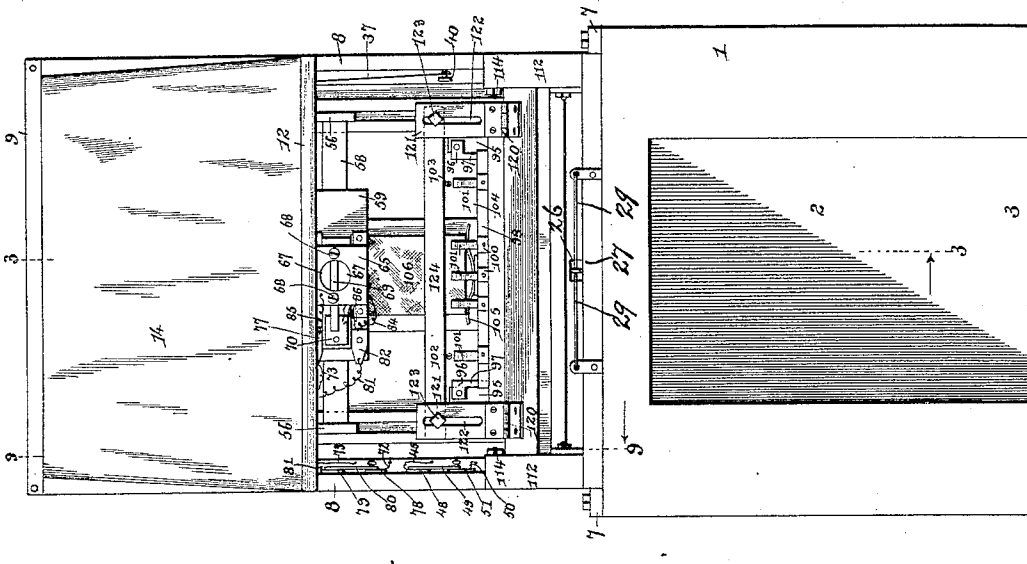

FIG. 1.

Witnesses

John K. McEachern
John H. Siggers

Inventor

Curtis Hornberger

By his Attorneys,

C. Snow & Co.

C. HORNBERGER.
 APPARATUS FOR RETOUCHING NEGATIVES.

No. 522,372.

Patented July 3, 1894.

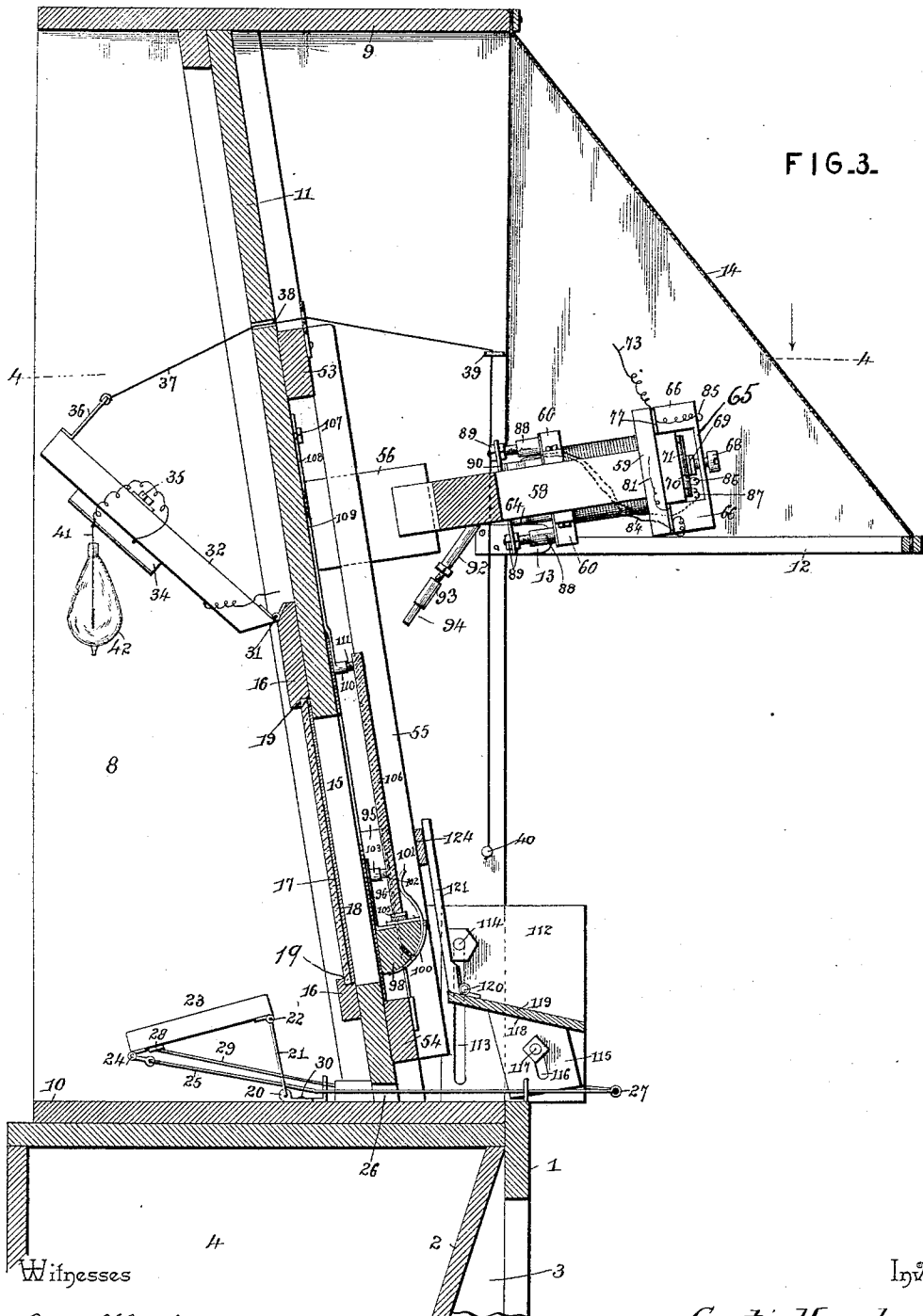

FIG. 3.

Witnesses
James K. McCutchan
J. S. Tiggers,

Inventor
Curtis Hornberger
 By his Attorneys,
C. A. Snow & Co.

C. HORNBERGER.
APPARATUS FOR RETOUCHING NEGATIVES.

No. 522,372.

Patented July 3, 1894.

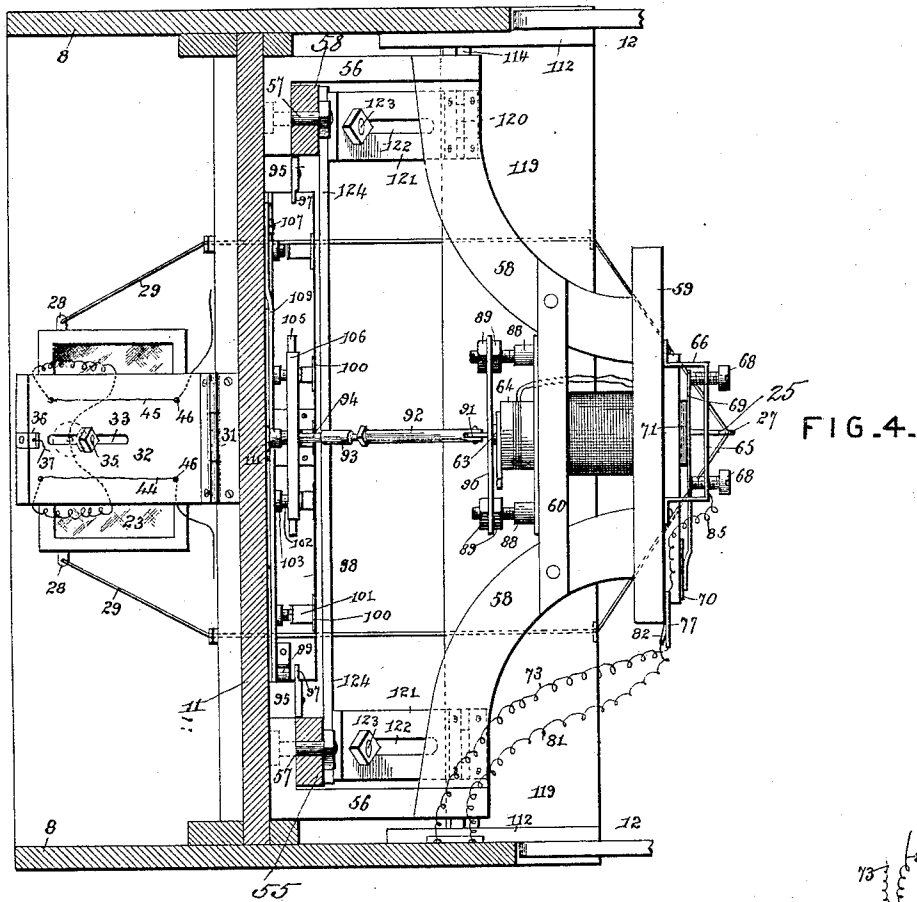

FIG. 4.

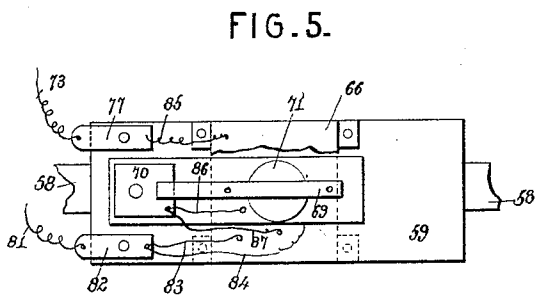
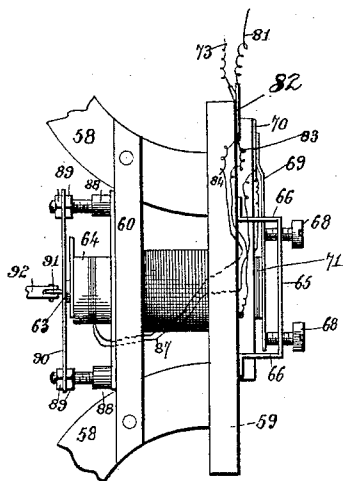

FIG. 5.

FIG. 6.



Witnesses

Jas. K. McLaughlin
J. H. Tiggers

Inventor

Curtis Hornberger

By his Attorneys,

C. A. Snow & Co.

C. HORNBERGER.

APPARATUS FOR RETOUCHING NEGATIVES.

No. 522,372.

Patented July 3, 1894.

FIG. 9.

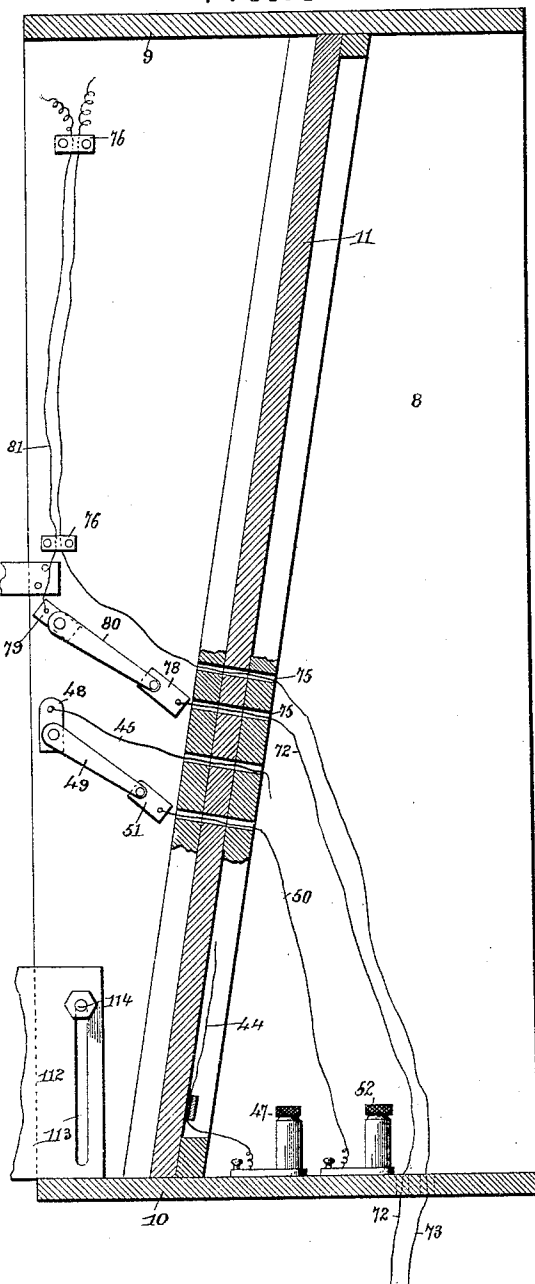

FIG. 7.

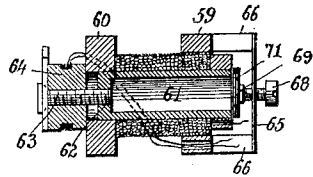

FIG. 8.

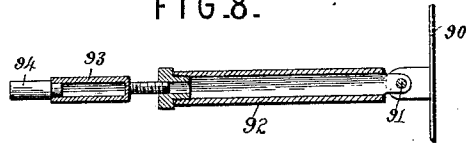

FIG. 10.

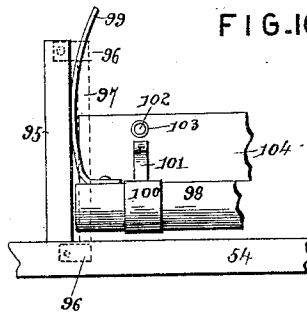
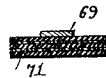

FIG. 11.



Witnesses

Jas. K. McLaughlin
J. H. Diggers

Inventor

Curtis Hornberger

By his Attorneys,

C. Snow & Co.

UNITED STATES PATENT OFFICE.

CURTIS HORNBERGER, OF HARRISONVILLE, MISSOURI, ASSIGNOR OF ONE-HALF TO M. F. TRIPLETT, OF SAME PLACE.

APPARATUS FOR RETOUCHING NEGATIVES.

SPECIFICATION forming part of Letters Patent No. 522,372, dated July 3, 1894.

Application filed December 20, 1892. Serial No. 455,753. (No model.)

To all whom it may concern:

Be it known that I, CURTIS HORNBERGER, a citizen of the United States, residing at Harrisonville, in the county of Cass and State of Missouri, have invented a new and useful Improvement in Apparatus for Retouching Negatives, of which the following is a specification.

My invention relates to a machine for retouching negatives; the objects in view being to provide a machine adapted to conveniently support photographic negatives for the purpose of retouching the same, and which is electrically operated to vibrate said negatives so that stipples may be produced thereon by the mere passage of the retouching crayon thereover; and furthermore, to provide means for lighting said negatives, whereby their outlines are clearly defined to the retoucher.

With these main objects in view, and many other minor objects not necessary to mention, the invention consists in certain features of construction hereinafter specified and particularly pointed out in the claims.

Referring to the drawings:—Figure 1 is a front elevation of a machine embodying my invention. Fig. 2 is a rear elevation of the same. Fig. 3 is a vertical longitudinal sectional view. Fig. 4 is a transverse or horizontal section on line 4—4. Fig. 5 is an elevation of the magnet support, the parts being broken away to show the armature. Fig. 6 is a bottom plan of the same. Fig. 7 is a longitudinal section of the magnet and its adjuncts. Fig. 8 is a similar view of the magnet-controlled arm. Fig. 9 is a vertical longitudinal section at one side of the center of the machine illustrating the switches for controlling the operations of the magnet and the light. Fig. 10 is a detail of one end of the negative-holder H showing the manner of supporting the same in an adjusted position. Fig. 11 is a section through the armature.

Like numerals of reference indicate like parts in all the figures of the drawings.

The stand 1 upon which the machine is mounted is rectangular and is provided with an inclined partition 2 whereby it is divided into a front compartment 3 and a rear compartment 4, the latter having hinged at one side a door 5. The rear compartment 4 ac-

commodates a battery 6, while the front compartment provides a space for the feet and legs of the operator. Between cleats 7, located at the opposite edges of the top of the stand, there is secured the framework of the machine, and the same consists of the opposite sides 8, the top 9, bottom 10, and inclined partition 11, which divides the same and inclines from a point near the rear edge of the top to a point near the front edge of the bottom. An awning or shade-frame 12 is hinged at 13 Fig. 3 to the front edges of the side walls 8, and the same is covered by a flexible material 14. This awning may be raised and lowered to give the proper effect and light to the work. The partition is provided near its lower end with an opening 15, in rear of which at its upper and lower sides is a pair of cleats 16, in which there is supported a ground glass 17, preferably covered upon its front with a layer of transparent paper 18 in order to soften the effect of the light hereinafter described as being located in rear thereof. The cleats 16 are rabbeted upon their adjacent edges, as indicated at 19, for the purpose of receiving the glass 17, and the glass may be removed by sliding it sidewise beyond the cleats.

Secured to the base 10 of the upper frame is a clip 20, and in this is loosely connected a wire-bail 21 to the free end of which is hinged as at 22 a mirror 23. A hinge 24 is located upon the outer edge of the mirror, and an operating rod 25 is connected to the hinge, passes forwardly through an opening 26 formed in the bottom of the partition, and terminates in front of the machine in a loop or eye 27. Eyes 28 are located at the opposite sides of the mirror, and diverging wires 29 are connected with the eyes, pass through perforations in the bottom of the partition 11 and likewise extend to the front of the same being passed through suitable guides and through the eye 27. It will thus be seen that through the medium of the rod 25 the mirror may be given any inclination, or be raised and lowered. In giving it inclination the mirror swings on the hinge 22, and in raising and lowering the bail swings up and down on the bearing clip 20. It will be seen that through the medium of the wires 29 the mirror may

be drawn either to the right or left. In order to secure this horizontal movement of the glass, the clip 20 is pivoted by a pin 30 to the base 10.

5 Hinged to the upper edge of the upper cleat 16, as at 31, is an arm 32, which is provided with a longitudinal slot 33, best shown in Figs. 2 and 4. Located upon the under side of the arm is a sliding-block 34 and a
10 bolt 35 passes through the block and the slot 33 in the arm, whereby by loosening the nut of the bolt the aforesaid block may be moved or adjusted within the slot of the arm and secured at any point of its adjustment. An eye
15 36 is secured to the outer or free end of the arm, and a cord 37 is secured to the eye, passed through a perforation 38 formed in the partition 11 above the arm, to the front of the same, and downwardly through a guide eye 39, lo-
20 cated upon the side-wall 8 of the frame, finally terminating adjacent to a pin 40 projecting from said side wall around which the cord may be wound. It will be seen that by means of the cord, the arm may be raised and lowered,
25 and, by engaging the cord upon the pin it may be secured in any of its raised or lowered positions.

A pair of electrical conductors 41 supports an incandescent lamp 42 upon the under side
30 of the block 34 the two conductors having their opposite ends passed through perforations in the block and emerging from the sides of the same through perforations 43 formed in the block for that purpose. To
35 these conductors coiled electrical conductors 44 and 45 are connected, the same beyond their coils being passed through perforations in the arm along the upper side thereof and down through perforations 46 formed in the
40 arm (best shown in Fig. 4), and from thence, one, 44, extends to a binding post 47 located in rear of the partition 11, while its companion 45 extends through suitable supporting
45 clips, through perforations in the edge of the partition 11 to a contacting-plate 48, which is provided with a switch 49. A third conductor 50 is connected with a contacting-plate 51 within the path of the free end of the switch and has its opposite terminal connected to a
50 second binding-post 52. To these binding posts lead the conductors of any suitable dynamo so that by opening and closing the switch 49 the current may be completed or broken, and thus the incandescent lamp
55 lighted or shut off as desired. By adjusting this light and the glass the rays of the former may be thrown against the ground glass or back plate 17.

Secured to the front of the partition 11 near
60 the upper and lower ends thereof, is an upper and a lower cleat 53 and 54, respectively, which extends across the partition to the opposite side walls, and these cleats each support a pair of slotted guide strips 55. These guide-
65 strips are embraced upon their outer sides by L-shaped feet 56, best shown in Fig. 4, and from said feet there extend upwardly through

the slots in the strips adjusting bolts 57. By means of the adjusting bolts 57 the yoke that carries the magnet may be raised and lowered
70 in the slots which the bolts occupy and thus the magnet secured opposite the point of the negative upon which the stipple is operating. The length of the stipple agrees with the distance between the negative and the vibratory
75 diaphragm of the magnet so that when the magnet is adjusted to a point opposite the negative the stipple is directly at a right angle to the negative. Curved yoke-bars 58 extend from the upper end of the feet in-
80 wardly and are connected at their outer ends by a transverse head 59, and at the inner side of the same with a transverse cross-piece 60. The head 59 and cross-piece 60 are provided with aligning openings and in the same is
85 fitted a hollow magnet 61, best shown in Fig. 7. The inner end of the magnet has a threaded opening 62 in which a soft iron screw 63 is secured, upon which a soft iron nut or secondary magnet 64 is threaded. A brass plate
90 65 is located over the outer end of the magnet and is supported by feet 66 above and out of contact therewith, and is secured to the head 59. The plate is provided with a central circular opening 67, best shown in Fig. 1,
95 and at opposite sides of the opening contact-screws 68 are located. A spring-armature 69 is secured to a brass plate 70 upon the head 59 near one end of the latter, said spring-armature passes under the screws 68 and over
100 or across the front of the magnet 61, and over the latter is provided with an armature-plate 71 consisting of a series of disks. By regulating the contact screws 68 the armature may be regulated in its vibrations between the
105 contact-screws and the magnet.

A pair of conductors 72 and 73 leads from the battery 6 (best shown in Fig. 2) up through perforations 74 formed in the bottom of the stand 1 and of the frame of the machine
110 along the back of the partition 11, and through perforations 75 formed in said partition to one of the side-walls 8, all as best shown in Fig. 9. The conductor 73 after passing through suitable clips 76 is coiled and connected to a
115 conducting-plate 77 located on one end of the head 59. The other terminal 72 leads to a contact-plate 78 located upon one of the side walls 8 adjacent to the switch 49. A conducting plate 79 is located adjacent to the plate
120 78 and carries a switch-lever 80 adapted to have contact with the plate 78. A conductor 81 which is but a continuation of the conductor 72 leads from the plate 79 through the series of clips 76 and terminates at a conduct-
125 ing plate 82 located upon one end of the head 59 opposite the plate 77.

From the contact-plate 82 leads a pair of conductors 83 and 84, the former conductor being of greater resistance than the latter and
130 composed of finer wire. The conductor 83 is connected with the magnetic coil of the secondary magnet 64, and continuing around the same merges therefrom, being designated as

the terminal 87, of which it is a practical continuation, and is connected to the contact plate 70. The remaining branch wire 84 leads from the contact-plate 82 to the coil of the main magnet, and after continuing around the same merges therefrom as the terminal wire 86, being likewise connected to the plate 70. In this manner it will be seen that the current is divided by what might be termed a shunt circuit, the latter circuit serving to strengthen the magnet at its lower end.

The operation of the magnets will be readily understood, and may be briefly stated as follows:—The electric current passing from the wire 81 is divided, as before stated, and passes around the main and auxiliary magnets, and back to the plate 70, from whence it passes to the spring armature, along the same, and out through the contact screws 68 to the frame 66, thence through the short wire 65 to the remaining terminal or conductor 73, and back to the battery. This completes the circuit, and magnetizes the magnets, which causes them to attract the armature and the diaphragm 90. As soon as the armature is attracted by the main magnet the electrical current is broken, and consequently the magnet becomes demagnetized and the spring armature automatically returns to its contact position with the screws 68, thus re-establishing the circuit. It will thus be seen that the armature makes and breaks the circuit, or in other words, is a circuit-breaker, and each time that the circuit is established the diaphragm is drawn upward and as soon as the circuit is broken it returns to its former position, so that it is maintained in a constant state of vibration.

Posts 88 suitably insulated depend or extend inward from the cross-piece 60, the said posts being threaded and each provided with a pair of clamping-nuts 89. These posts pass through and the nuts clamp upon a vibratory diaphragm 90 located at the inner side of the inner end of the magnet. To the center of the plate there is pivotally connected, by a binding screw 91, a hollow arm 92 of brass, and into the lower end of the same is screwed adjustably a socket 93, in whose lower end is fitted preferably a rubber plug 94.

Rising from the lower cross-cleat 54 and within the guide-strips is a pair of cleats 95. These cleats are provided at their upper and lower ends with metal plates 96, and bowed between the same is a pair of flat springs 97. A cross-bar 98 has its ends chamfered to overlap the springs 97 and is located between the cleats, the springs, and under side of the cross-bar having frictional contact. The ends of the cross-bar are provided with bowed-springs 99, and these take yieldingly against the inner sides of the cleats 95 and under the springs 97 and aid the latter in retaining the cross-bar at any desired point of elevation.

At intervals, spring-plates 100 are connected to the cross-strip and to each spring-

plate there is secured a spring tongue 101, said spring tongues resting at their free ends upon, in this instance, soft rubber plugs 102, which are arranged in a transverse series and inserted in sockets 103 formed on a metal-frame 104, which is secured to the aforesaid cross-strip. Upon the upper side of the cross-strip a bowed spring 105 is mounted and secured at its center, its terminals serving as a yielding support for the lower edge of the negative 106.

A bolt 107, extends from the inclined partition 11 and the same passes through the slot 108 of an arm 109, said arm having at its free end a socket 110, in which is mounted a rubber plug 111.

The negative to be operated upon is placed upon the spring-rests 105, the spring tongues 101 resting thereagainst and serving to retain it in position. If the negative be a large one the arm 109 serves to support the upper end of it, or if it be a small one the lower resilient plugs 102 may be depended upon for this purpose. If desired, as before stated, the arm 109 need not be used. That is to say, it is used where the "dot"-stipple is desired, but where the "dash" or "comma" is desired this arm is not used. The negative having been mounted in position and the light adjusted together with the mirror, so as to reflect the same through the negative, the arm 92 is swung toward the negative so that its lower end bears thereon. Through the medium now of the switch 80 the electrical current is turned on and the armature and diaphragm 90 are vibrated in a manner that will be obvious. Inasmuch as the distance between the vibratory plate and negative and the length of the arm 49 as adjusted is the same it will be seen that the vibrations of the diaphragm will give a corresponding or vibratory movement to the negative, so that a crayon for retouching purposes being drawn over the negative the latter will be thrown into and out of contact with the point of the crayon, and thus the "dot"-stipple or "comma"-stipple produced as may be desired. A pair of blocks 112 (best shown in Fig. 3) is located at the inner sides of the sides 8 and are longitudinally slotted near their inner edges at 113 to receive adjacent bolts 114, whereby the blocks may be raised and lowered and adjusted. Plates 115 having slots 116 are located at the inner sides of the blocks 112, and adjacent bolts 117 pass through the slots of the plates and project from the blocks. The upper faces or edges of the plates are inclined, as at 118, and upon these inclined edges and secured thereto, is a counter 119. Hinged to the opposite ends and at the inner edge of the counter as at 120 is a pair of side strips 121 and these strips are longitudinally slotted as at 122 (see Fig. 1) for the reception of bolts 123, which project from a cross-piece or rest 124 adapted to support the hand of the operator. It will be seen that this cross-piece, together with the strips 121 may be

swung down upon the counter out of the way when introducing or removing the negative to or from the machine; and furthermore that by means of the bolts 114 and 117 any inclination or elevation that the operator may desire will be readily produced. Furthermore, it will be seen that the cross-strip 98 may be raised and lowered and thus the negative raised and lowered, so that various portions of the negative, or in fact, any point whatever may be brought opposite the light opening in the partition 11.

From the foregoing description in connection with the accompanying drawings it will be seen that I have provided a machine in which the operation of retouching or stippling negatives may be carried on, and this in a most efficient and artistic manner producing either the "comma" or "dot" stipple as desired and rendering clear all parts of the negative to the eye of the operator.

Having described my invention, what I claim is—

1. In a photographic retoucher, the combination with an elastic negative support, of an opposite independent arm adapted to bear upon that side of the negative opposite to which it is supported, means for giving a reciprocating motion to the arm, and a support to which said arm is pivotally connected, substantially as specified.

2. In a photographic retoucher, the combination with an elastic negative support, of a longitudinally adjustable arm adapted to bear upon the negative at that side opposite to which it is supported, means for reciprocating the arm, and a movable support to which the arm is hinged, substantially as specified.

3. In a photographic retoucher, the combination with a yielding negative support, of an independent arm located at that side of the negative opposite to the support, means for adjusting the arm to bear against the negative, and an electrically operated support for the arm adapted to rapidly reciprocate the same, substantially as specified.

4. In a photographic retoucher, the combination with a yielding negative support, of an adjustable arm located opposite the support, an electrical magnet, and a diaphragm operated thereby and connected with the arm to reciprocate the latter, substantially as specified.

5. In a photographic retoucher, the combination with a yielding negative support, of a magnet located in front thereof, a diaphragm operated by the magnet, means for adjusting the magnet, and an arm interposed between the diaphragm and negative, connected to the former, and binding on the latter, substantially as specified.

6. In a photographic retoucher, the combination with a yielding negative support, a magnet arranged in front of said support and at the opposite side of the negative, a vibrating diaphragm located below the magnet, and an arm hinged at its upper end to the dia-

phragm and adapted to bear at its lower end against the negative, substantially as specified.

7. In a photographic retoucher, the combination with a yielding negative support, of a magnet located in front of the support, and an arm pivoted to the diaphragm and provided at its opposite end with a rubber plug adapted to bind upon the negative, substantially as specified.

8. In a photographic retoucher, the combination with a frame having an inclined support provided with an opening, and yielding negative supports located adjacent to the opening, of opposite slotted guide-strips, L-shaped feet embracing the same, bolts passing through the slots and feet, yoke-bars extending from the feet inward, a head connecting the outer ends of the yoke-bars, and a cross-piece connecting said yoke-bars below the head, said head and cross-piece having openings, a magnet located in the openings, an armature mounted in the head, threaded studs insulated and extending from the cross-piece, a diaphragm adjustably mounted on the studs, and an arm hinged to the diaphragm and adapted at its lower end to bear upon the negative, substantially as specified.

9. In a photographic retoucher, the combination with a yielding negative support, a yoke-frame arranged in front of the same, main and auxiliary magnets located in the yoke-frame, electrical conductors leading to the yoke-frame, branch-wires leading from one of the conductors to the main and auxiliary magnets and to the remaining conductor, an armature arranged over the main magnet, a diaphragm arranged under the auxiliary magnet, and an arm hinged to the diaphragm and adapted to bear upon the negative, substantially as specified.

10. In a photographic retoucher, the combination with a framework having a partition provided with an opening, and adjacent yielding negative supports, of a yoke-frame comprising a head and a cross-piece 59 and 60 respectively provided with openings, a hollow magnet seated in the openings, a soft iron bolt threaded in the lower end of the magnet and provided with a soft iron nut forming a secondary magnet, a diaphragm located below the secondary magnet, an arm connected to the diaphragm and adapted to bear against the negative, a plate 65 having an opening above the upper end of the hollow magnet, contact points on the plate, a plate secured on the head, a spring armature mounted on the plate, electrical plates 77 and 82, electrical conductors 72 and 73 connected with the plates 77 and 82, branch-wires 83 and 84 leading from the plate 82 and connected with the coils of the upper and lower magnets, branch-wires 86 and 87 leading from the coils of the two magnets to the plates 70 of the armature, and a single wire 85 leading from the plate 66 to the plate 77, a contact-plate 78 located in the circuit, a contact-plate 79, a switch 80

pivoted to one contact-plate and adapted to contact with the remaining plate, and a battery arranged in the circuit, substantially as specified.

5 11. In a photographic retoucher, the combination with a cabinet or frame having a negative support, slotted blocks located at opposite sides of the support, bolts extending through the sides of the frame into the slots,
10 bolts extending from the blocks, plates having slots to receive the bolts and provided with inclined upper edges, a counter supported upon said edges, slotted bars hinged to the inner edge of the counter, a cross-piece
15 or rest connecting the bars, and bolts passed through the slots and the rest, substantially as specified.

12. In a photographic retoucher, the combination with a frame having a support provided with an opening, of opposite vertical
20 guide cleats, a cross-piece arranged between the same for vertical movement, means for locking the cross-piece in adjusted positions, a back frame extending from the cross-piece
25 and provided with forwardly extending studs, spring fingers extending from the cross-piece and terminating opposite the studs, and a negative support arranged upon the cross-piece, substantially as specified.

30 13. In a photographic retoucher, the combination with a frame having an inclined sup-

port provided with an opening, a bar arranged below the opening, opposite vertical cleats rising from the bar, upper and lower plates arranged on the bar and cleats, and a bowed
35 spring secured to the plates, of a cross-piece arranged between the bars and mortised at its ends to engage the springs, a metal plate rising from the rear edge of the cross-piece
40 and provided with sockets, yielding studs mounted in the sockets, spring fingers extending from the cross-piece and terminating in front of the studs, and an electrically operating binding device for bearing on the negative,
45 substantially as specified.

14. In a photographic retoucher, the combination with a frame provided with a support having an opening, of a series of yielding negative supports arranged below the opening, a
50 stud extending from the support above the opening, an arm slotted and mounted on the stud and provided at one end with a socket having a rubber plug, and an electrically operated arm for bearing on the negative, substantially as specified.
55

In testimony that I claim the foregoing as my own I have hereto affixed my signature in the presence of two witnesses.

CURTIS HORNBERGER.

Witnesses:

JOHN C. BRIDGES,
RICHARD P. WARREN.