

T. W. JINKENS.
DUMPING WAGON.

APPLICATION FILED MAR. 10, 1903.

NO MODEL.

4 SHEETS—SHEET 1.

Fig. 1.

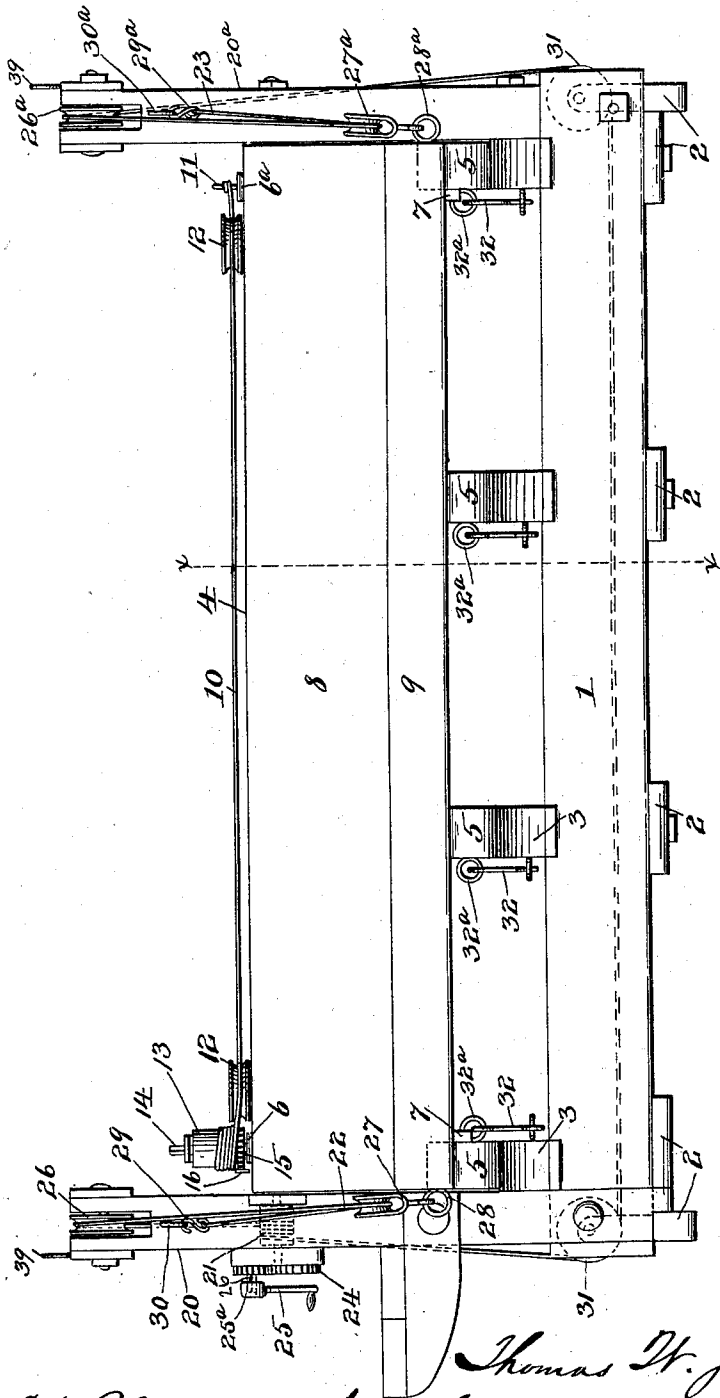

Witnesses
James Blackwood
A. Kaworth, Jr.

Inventor
Thomas W. Jinkens
 by *L. A. Gouwick*
 Attorney

T. W. JINKENS.
DUMPING WAGON.

APPLICATION FILED MAR. 10, 1903.

NO MODEL.

4 SHEETS—SHEET 3.

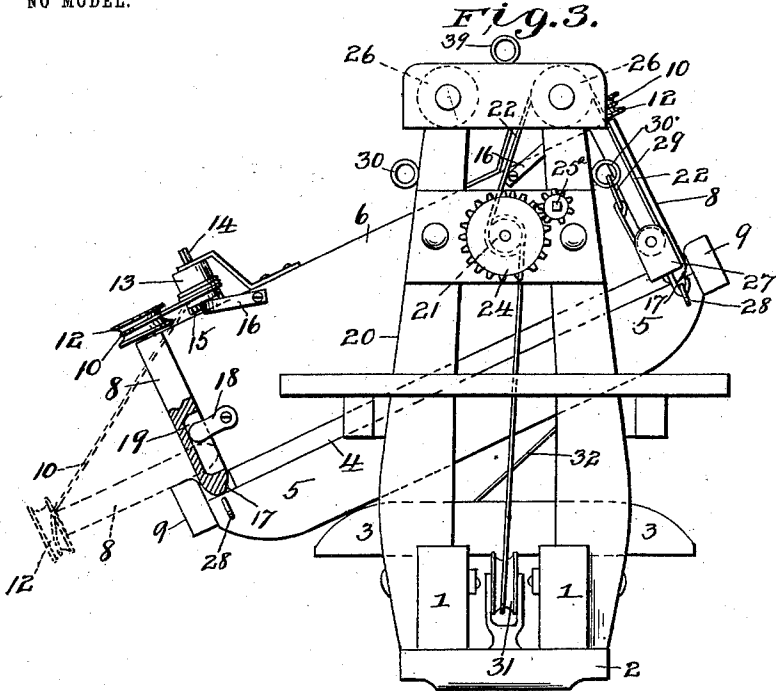

Fig. 3.

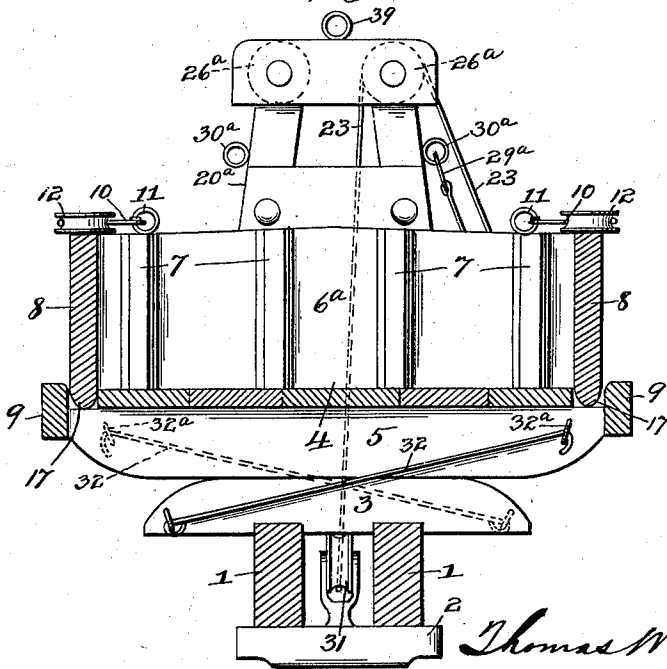

Fig. 4.

Inventor

Thomas W. Jinkens
by D. A. Gourick
Attorney

Witnesses

J. Blackwood
W. Kauderph, Jr.

T. W. JINKENS.
DUMPING WAGON.

APPLICATION FILED MAR. 10, 1903.

NO MODEL.

4 SHEETS—SHEET 4.

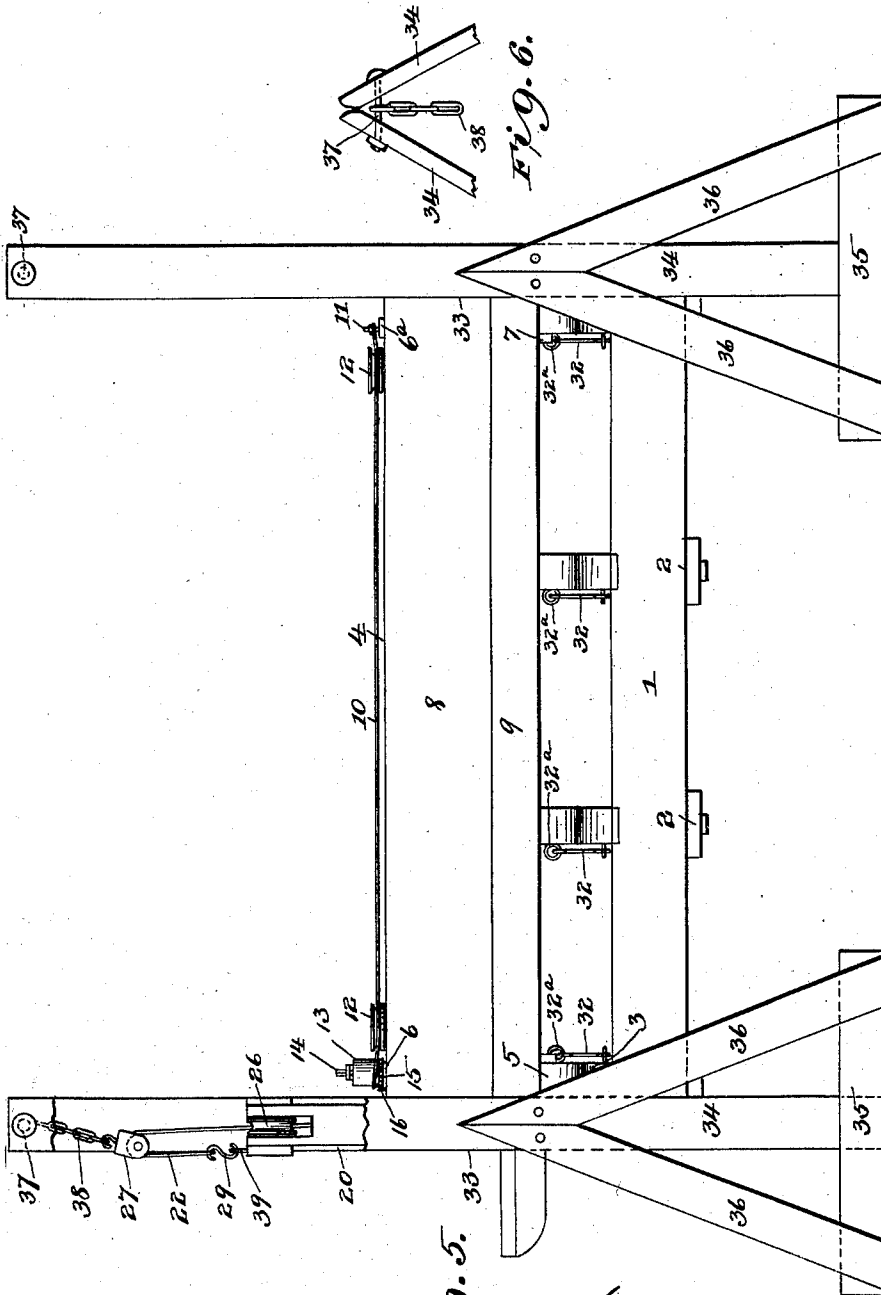

Fig. 5.

Fig. 6.

Witnesses
Joseph Blackwood
Frederick, Jr.

Inventor
Thomas W. Jinkens
 by *S. M. Souwier*
 Attorney

UNITED STATES PATENT OFFICE.

THOMAS W. JINKENS, OF FORT COLLINS, COLORADO, ASSIGNOR OF ONE-THIRD TO FREDERIC GROSE, OF FORT COLLINS, COLORADO.

DUMPING-WAGON.

SPECIFICATION forming part of Letters Patent No. 748,190, dated December 29, 1903.

Application filed March 10, 1903. Serial No. 147,177. (No model.)

To all whom it may concern:

Be it known that I, THOMAS W. JINKENS, a citizen of the United States, residing at Fort Collins, in the county of Larimer and State of Colorado, have invented certain new and useful Improvements in Dumping-Wagons, of which the following is a specification.

My invention relates to dumping-wagons of that class in which the body of the wagon dumps on either side, and has for one of its objects to provide a support having curved bolsters and rockers on the wagon-body resting on said bolsters, together with means to tilt the wagon-body to either side.

Another object of my invention is to provide derricks for supporting the wagon-body when lifted from the running-gear, the same power that is used to dump the wagon-body being adapted for use in conjunction with said derricks to raise and lower the body.

The advantages of my invention will more fully appear hereinafter and by reference to the accompanying drawings, in which—

Figure 1 is a side view in elevation of my invention; Fig. 2, a top plan view; Fig. 3, a front view in elevation showing the wagon in the act of dumping; Fig. 4, a sectional view on the line $x x$ of Fig. 1; Fig. 5, a view illustrating my device for raising the wagon-body from the running-gear and supporting it, and Fig. 6 a detail view of the top of one of the derricks shown in Fig. 5.

Referring to the drawings, in which similar reference characters indicate corresponding parts throughout the several views, 1 represents two timbers extending longitudinally of the frame, which I shall call "sills" and which are adapted to rest upon a running-gear of any desired construction, and 2 represents cross-braces connecting the sills 1, this construction constituting a horizontal frame. 3 represents bolsters secured to said sills 1, having their top sides curved, and 4 represents the wagon-body, having rockers 5 to rest on bolsters 3.

6 and 6^a represent the front and rear end boards, respectively, of the body secured to posts 7, supported by the end rockers, while 8 represents the side boards, supported on the ends of rockers 5, 9 being side pieces secured to the ends of said rockers and projecting above their tops, forming recesses on

each side of the body 4 to receive said side boards. The side boards 8 are operated by means of cables or chains 10, secured on the rear end board 6^a at 11 and passing around sheaves or pulleys 12 on the top edge of each said boards 8 and then around a drum 13, journaled on the front end board 6. Drum 13 has its shaft 14 squared to receive a crank for operating the drum, while 15 represents a ratchet formed on the lower edge of the drum, and 16 a pawl pivoted on end board 6, so that it can be thrown into and out of engagement with ratchet 15. It will be readily understood from this description of the side boards that they are held in position by means of cables or chains 10. When it is desired to lower the side boards, pawl 16 is thrown out of engagement with ratchet 15, and the side of body 4 having been lowered the weight of the board lowers it, so that the material contained in the body is dumped. The lower edge of board 8 is curved, as shown at 17, to permit a free movement thereof, while to prevent end play of the boards when closed against the wagon-body I provide pins 18 on the sides of end boards 6 and 6^a, which fit into recesses 19 in said boards.

20 represents an upright frame secured at the front end of the wagon on sills 1, having the drum 21 journaled therein, to which is attached the cables 22 and 23, drum 21 being actuated by gearing 24, operated by a crank 25, loosely mounted on shaft 26. Cable 22 passes upward and over the top of frame 20, where there are journaled two sheaves 26, so as to permit the cable 22 to be attached to either side of body 4, 27 representing a block on said cable adapted to hook into ring 28 on the end of front rocker 5, while the end of cable 22 is provided with a hook or other suitable securing device 29, to be secured in ring 30 on said frame 20. At the rear end of the wagon another frame 20^a is erected corresponding in construction with frame 20, except that no drum is provided thereon, cable 23 running downward from drum 21 around sheaves 31 on cross-braces 2 and upward and over one of the two sheaves 26^a, said cable also having a block 27^a to hook into ring 28^a on either side of rear rocker 6 and having a hook 29^a to be secured in a ring 30^a on frame 20^a. It will be understood from this con-

struction that wagon-body 4 may be dumped to either side desired by attaching the blocks 27 and 27^a to the rings 28 and 28^a on the side of said body opposite to the direction to be dumped and the hooks 29 and 29^a in the rings 30 and 30^a on the same side of frames 20 and 20^a, respectively. By turning drum 21 the wagon-body 4 is rocked in the direction desired and the contents dumped. To prevent the wagon-body rocking off of bolsters 3, I provide rods 32, pivotally secured to the ends of said bolsters and crossing under the wagon-body, secured to rings in the opposite ends of rockers 5 by means of hooks 32^a. These rods permit the wagon-body to rock freely to either side, while at the same time they prevent it slipping off its supports. If it is desired to detach the wagon-body from the supporting-frame, the rods 32 may be unhooked and the body lifted therefrom.

33 represents the wagon-body raisers, consisting of two V-shaped derricks composed of uprights 34, having base-pieces 35 and braces 36, connecting uprights 34 and the ends of said base-pieces 35. The upper ends of uprights 34 are loosely connected by means of rods 37, on which are secured chains 38. When it is desired to raise the wagon-body from the running-gear, the derricks 33 are erected over the frames 20 and 20^a, the blocks 27 and 27^a hooked into one of the links in chains 38, while the end of cables 22 and 23 are secured in rings 39 on the top of frames 20 and 20^a. The drum 21 is then rotated and the wagon-body lifted and held suspended from said derricks 33.

It will be readily understood that, if desired, the derricks 33 may be dispensed with and any other suitable support substituted—such, for instance, as chains secured in the rafters of a wagon-house, barn, &c.

Having thus described my invention, what I claim is—

1. In a dumping-wagon, a horizontal frame, curved bolsters supported by said frame, a wagon-body, rockers secured to said body and resting on said curved bolsters, and means to tilt said body to either side, substantially as shown and described.

2. In a dumping-wagon, a horizontal frame, curved bolsters supported by said frame, a wagon-body, rockers secured to said body and resting on said curved bolsters, rods secured to the ends of said bolsters and the opposite ends of the rockers, and means to tilt said body to either side, substantially as shown and described.

3. In a dumping-wagon, removable side pieces, sheaves journaled on said side pieces, a cable secured to one of the end boards of the body and passing around said sheaves, and drums journaled on the other end board to receive the free ends of said cables, substantially as shown and described.

4. In a dumping-wagon, a recess at each side of the wagon-body, side pieces seated in said recesses, sheaves journaled on said side

pieces, a cable secured to one of the end boards of the wagon-body and passing around said sheaves, and drums journaled on the other end board to receive the free ends of said cables, substantially as shown and described.

5. In a dumping-wagon, a horizontal frame, curved bolsters supported by said frame, a wagon-body, rockers secured to said body and resting on said curved bolsters, a drum suitably journaled on the wagon, and cables secured to said drum and arranged to be attached to either side of the wagon-body, substantially as shown and described.

6. In a dumping-wagon, a horizontal frame, curved bolsters supported by said frame, a wagon-body, rockers secured to said body and resting on said curved bolsters, rods secured to the ends of said bolsters and the opposite ends of the rockers, a drum suitably journaled on the wagon, and cables secured to said drum and arranged to be attached to either side of the wagon, substantially as shown and described.

7. In a dumping-wagon, a horizontal frame, an upright at each end of said horizontal frame, curved bolsters on said horizontal frame, a wagon-body, rockers secured to said body and resting on said curved bolsters, a drum journaled in the upright frame at the front of the wagon, two cables wrapped on said drum, one of said cables passing upward over the top of the front upright frame the other cable passing under the wagon-body to the rear upright frame, and means to attach said cables to either side of the ends of said wagon-body, substantially as shown and described.

8. In a dumping-wagon, horizontal sills, cross-pieces connecting said sills, curved bolsters on top of said sills, a wagon-body, rockers on said body to seat on said bolsters, rods pivotally secured to the ends of said bolsters having their free ends hooked, eyes on the ends of said rockers to receive the hooked ends of said rods, side pieces secured to the ends of said rockers spaced apart from the wagon-body, side boards mounted in the spaces between said side pieces and the wagon-body, sheaves journaled on the top edge of said side boards, cables secured to one of the end boards of the body, drums journaled on the other end board to receive the other ends of said cables, said cables passing around said sheaves, vertical frames on the ends of said sills, a drum journaled in one of said frames, and passing from said drum over the tops of said frames and attached to the side of the ends of said wagon-body, substantially as shown and described.

In testimony whereof I hereto affix my signature in the presence of two witnesses.

THOMAS W. JINKENS.

Witnesses:

GEORGE O. STAKEBAKE,
DAVID G. BROOKS.