

(No Model.)

2 Sheets—Sheet 1.

C. W. BOMAN.

MACHINE FOR CUTTING HELICALLY COILED SHAVINGS OR STRIPS.

No. 562,273.

Patented June 16, 1896.

Fig. 1.

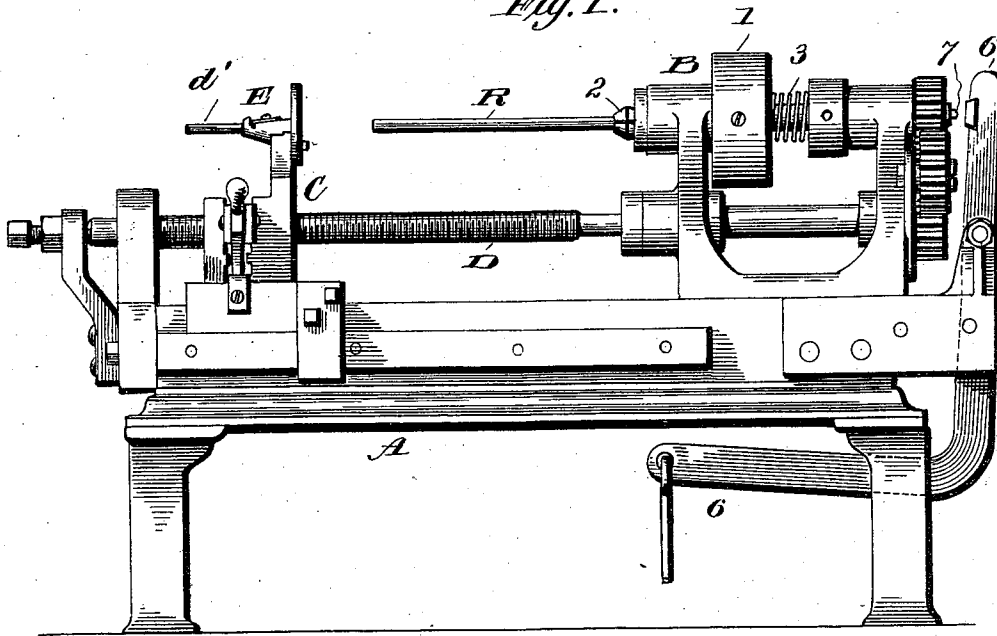

Fig. 2.

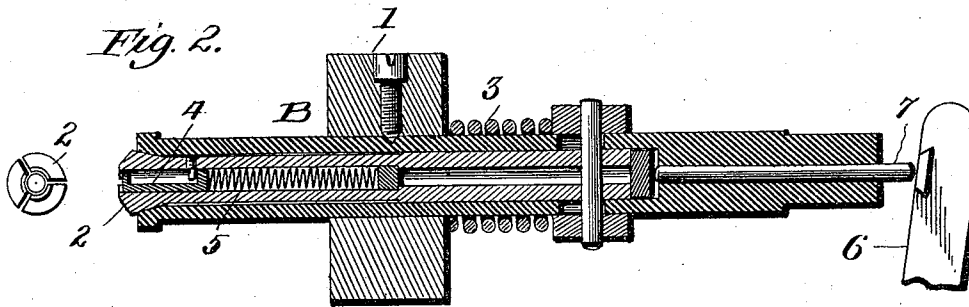
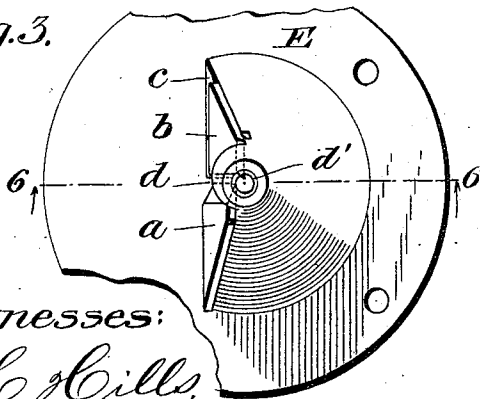
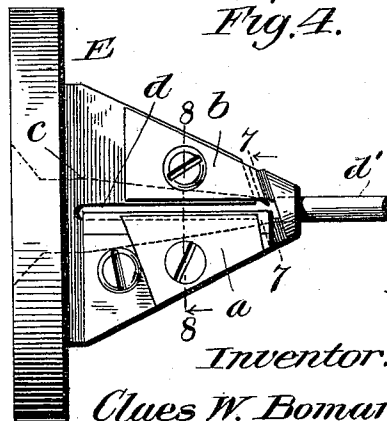

Fig. 3.



Witnesses:
L. C. Hills,
F. B. Keifer

Fig. 4.



Inventor:
Claes W. Boman,
 by *Marshall Parley*
his Atty.

C. W. BOMAN.

MACHINE FOR CUTTING HELICALLY COILED SHAVINGS OR STRIPS.

No. 562,273.

Patented June 16, 1896.

Fig. 5.

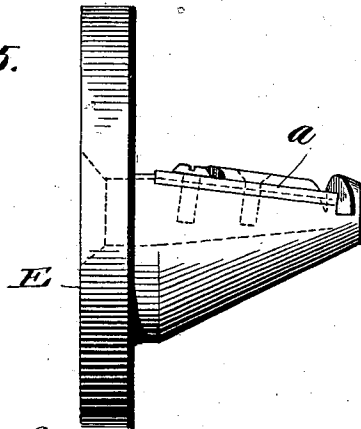

Fig. 7.

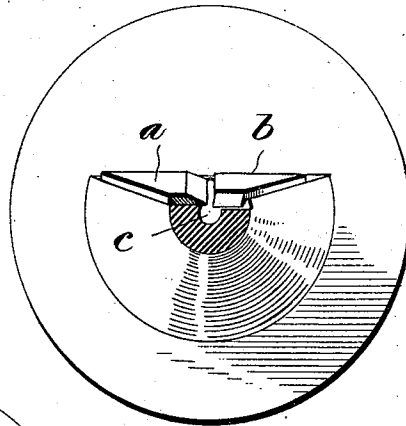

Fig. 6.

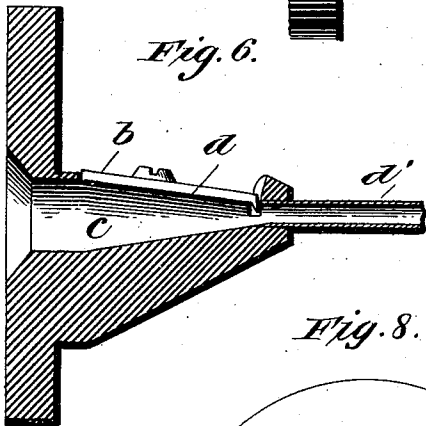

Fig. 8.

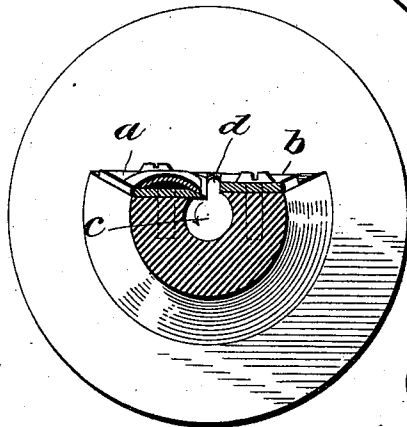

Fig. 9.



Fig. 10.

Fig. 11.

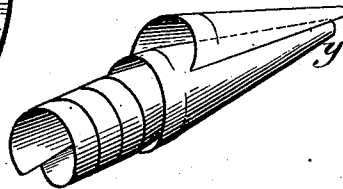
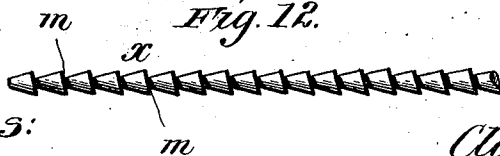

Fig. 12.



witnesses:

L. C. Hills
J. B. Keefe

Inventor:

Claes W. Boman,
by Maxwell Bailey
his Atty.

UNITED STATES PATENT OFFICE.

CLAES WM. BOMAN, OF NEW YORK, N. Y., ASSIGNOR TO THE EAGLE PENCIL COMPANY, OF SAME PLACE.

MACHINE FOR CUTTING HELICALLY-COILED SHAVINGS OR STRIPS.

SPECIFICATION forming part of Letters Patent No. 562,273, dated June 16, 1896.

Application filed March 31, 1896. Serial No. 585,536. (No model.)

To all whom it may concern:

Be it known that I, CLAES WILLIAM BOMAN, a citizen of the United States, and a resident of the city, county, and State of New York, have invented certain new and useful Improvements in Machinery for Cutting Helically-Coiled Shavings or Strips, of which the following is a specification.

My invention is directed to machinery for the production of the helically-coiled shaving or strip which forms the case or sheath of the pencil that is the subject of my Letters Patent No. 554,212 of February 4, 1896; and it is in this connection that I shall describe it, although I desire it to be understood that I do not limit myself to that particular use of the machine. It may be used in any connection where it is desired to produce a helically-coiled strip or shaving of any suitable material for any purpose.

My invention resides, essentially, in the cutter by which the strip is formed and severed from the stick. This cutter can be used in any suitable lathe in which the chuck and the cutter-carriage have the requisite feed movement with respect to one another, and in which rotation is imparted to either one or both of them.

I will first describe my invention in its preferred embodiment by reference to the accompanying drawings and will then point out in the claim those features which I believe to be new and of my own invention.

In the drawings, Figure 1 is a view of a machine embodying my invention. Fig. 2 is a longitudinal central section of the revolving work-holding chuck. Fig. 3 is a front elevation, Fig. 4 is a plan, and Fig. 5 is a side elevation, of a cutter embodying my invention. Fig. 6 is a section of the same on line 6 6, Fig. 3. Fig. 7 is a section on line 7 7, Fig. 4. Fig. 8 is a section on line 8 8, Fig. 4. Figs. 9 and 10 are views of the two cutting-blades detached. Fig. 11 represents a piece of the shaving cut by the machine. Fig. 12 represents a piece of the core left by the cutting operation.

The machine shown in the drawings is in its general organization not substantially different from an ordinary lathe.

A is the frame.

B is the power-driven rotary work-holding chuck.

C is the cutter-carriage, having movement to and from the chuck and actuated in its feed movement by the screw-shaft D, driven by gearing in the customary way from the chuck.

Power is applied to the chuck through its pulley 1, which is belted to some suitable prime mover. The chuck contains spring expanding work-holding jaws 2, normally retracted by a stout spring 3 within the body of the chuck, so as to close upon the work. Within the space inclosed by the jaws 2 is a longitudinally-movable ejector 4, impelled forward by a spring 5 to press against the butt of the stick held in the jaws, and to eject it from the chuck when the jaws are moved forward or outwardly from the chuck and thus are permitted to expand and release the work. The jaws are thus moved by the usual hand or foot operated lever 6, arranged to press forward a sliding pin 7, which bears against the base or rear end of the shank on which the spring expanding-jaws are mounted.

Thus far there is nothing essentially new in the machine.

In the chuck is shown the wooden rod R, from which the helical shaving or strip is to be cut. This rod is a solid cylindrical wooden stick which prior to being put into the chuck has been steamed or soaked, so as to be thoroughly softened and free from brittleness.

The cutter, suitably mounted and held in the cutter-carrier or head-stock C, consists of a cutter-head E and two blades *a b*. The cutter-head has a tapering or conical passage *c* through it, having its base opening toward the chuck, and having its sides tapering or inclined to accord with the inclination which the folds of the helix are to stand to the axis of said helix. On one side of the conical passage the head has formed in it a longitudinal slot *d* and is cut away on top flatwise to form a seat for the blade *a*, the cutting edge of which projects into the conical passage a distance equal to the thickness of cut which it is to make. This cutting edge slants from front to rear, so as to stand on an incline conforming to that of the internal taper of the cutter-head.

The cutter-head internally at its base, or at that point where the stick first meets the blade *a*, is of the diameter of the stick, and it thence tapers toward its front end or nozzle, where it
5 is of a diameter about equal to that of the pencil-lead which is to be held in the sheath made from the stick.

The blade *a* at its front or outer end does not extend inwardly to the longitudinal axis
10 of the cutter-head, but stops short thereof far enough to leave a certain uncut portion at the center of the stick, which becomes the core *x*, the removal of which from the helix leaves the passage which afterward is filled
15 by the lead; but in cutting a helical shaving from the stick with the blade *a*, the shaving *y* at the front edge will be still joined to the core, and will necessarily be torn therefrom as the work progresses, thus damaging the
20 shaving. To avoid any such occurrence, I provide the second cutter *b*, which at its front end has a cutting point or edge transverse to the longitudinal axis of the cutter-head and projecting into the bore of the cutter-head at
25 the front just far enough to make a transverse cut in the tapered front end of the stick just deep enough to sever the shaving from the core. The cut made by this blade *b* is marked *m* in Fig. 12. The core as it separates from the shaving passes out through the
30 nozzle of the cutter-head and a tube *d*, fast to the nozzle.

Both blades *a* and *b* necessarily cut in a spiral path, by reason of the fact that the cutter-carriage is continuously traveling toward
35 the work-holding chuck while the cuts are be-

ing made. The rate of rotation of the chuck relatively to the speed of the feed movement will determine the thickness of the shaving cut, and the blade *b* is so located with refer-
40 ence to the blade *a* as to meet the stick just at the forward extremity of the cut made in the stick by the blade *a*, the one blade thus serving to cut the stick into a shaving the
45 helical folds of which as they are formed are severed from the core by the other blade.

Having described my invention and the best way now known to me of carrying the same into effect, what I claim herein as new,
50 and desire to secure by Letters Patent, is—

In machinery for cutting helically-coiled shavings or strips, a longitudinally-slotted cutter-head having a conical or tapering pas-
55 sage for the stick to be cut, a longitudinal blade seated on one side of the slot in said head, with its edge projecting through the slot into said passage and substantially parallel with the walls of the same, for cutting the
60 helical shaving from the stick, and a cross-blade seated on the other side of said slot, and projecting into the passage in the cutter-head at the nozzle end a sufficient distance to
65 sever from the core the shaving cut by the other blade, substantially as and for the purposes hereinbefore set forth.

In testimony whereof I have hereunto set my hand this 30th day of March, 1896.

CLAES WM. BOMAN.

Witnesses:

SAMUEL KRAUS,
OTTO GUGENHEIM.