



(22) Date de dépôt/Filing Date: 1997/03/19

(41) Mise à la disp. pub./Open to Public Insp.: 1997/09/20

(45) Date de délivrance/Issue Date: 2005/01/18

(30) Priorité/Priority: 1996/03/20 (961142) NO

(51) Cl.Int.⁶/Int.Cl.⁶ B22D 11/04, B22D 9/00

(72) Inventeurs/Inventors:

STEEN, IDAR KJETIL, NO;
AALMO, LEIF, NO;
SANDVOLL, SIGMUND, NO;
ODEGARD, MAGNE, NO;
HAKONSEN, ARILD, NO;
SIVERSEN, JAN, NO;
NAESS, HARALD, JR., NO;
HEGGSETH, BJARNE, NO

(73) Propriétaire/Owner:

NORSK HYDRO ASA, NO

(74) Agent: FETHERSTONHAUGH & CO.

(54) Titre : INSTALLATION DE COULEE CONTINUE DE METAUX

(54) Title: EQUIPMENT FOR CONTINUOUS CASTING OF METALS

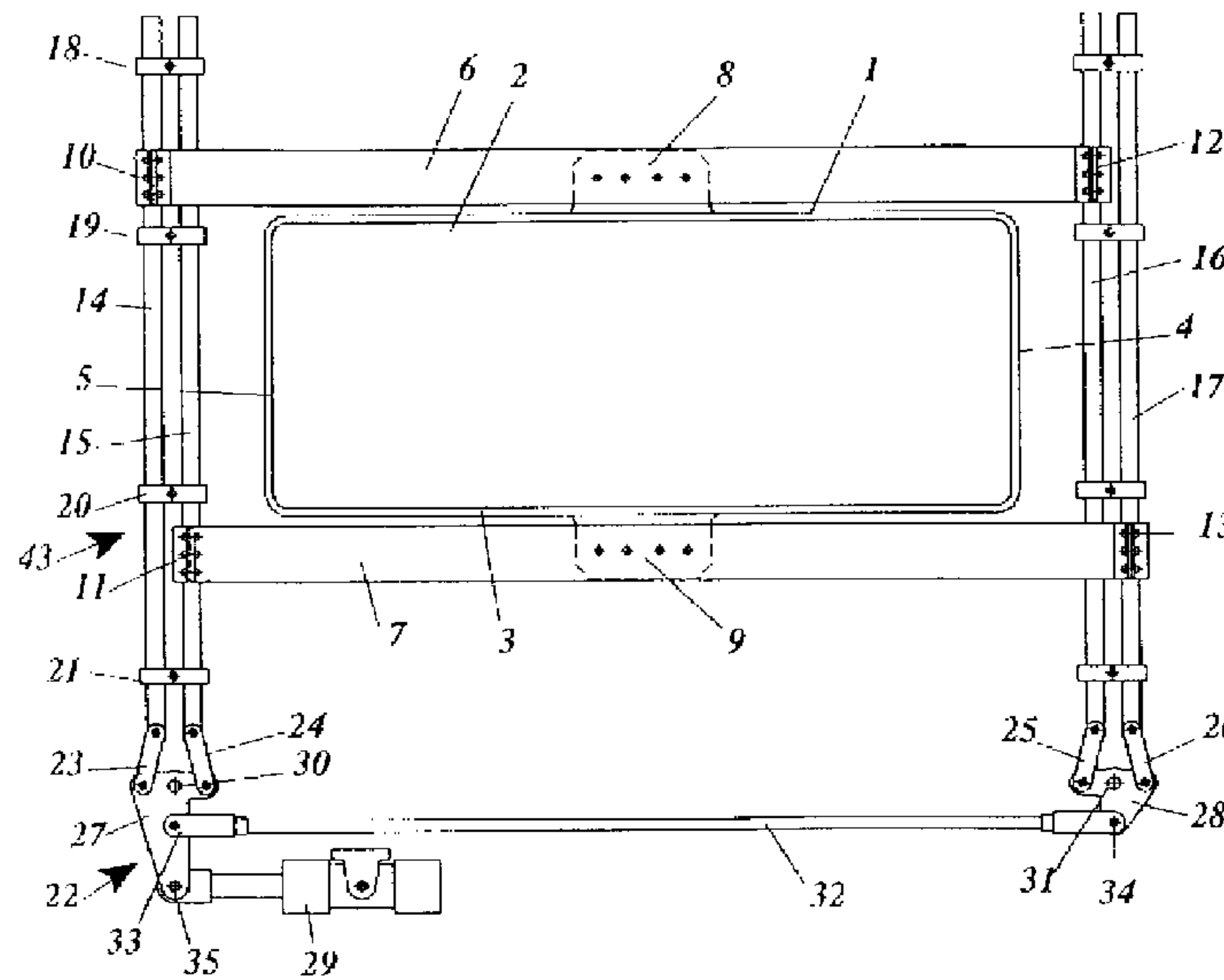

(57) Abrégé/Abstract:

Equipment for continuous casting of strands of metals, preferentially ingots of aluminium. The equipment comprises a flexible casting mould 1 that may be rectangular with two side faces 4, 5 restrained against movement and two flexible side faces 2, 3. The flexible side faces are provided with a stiffening part 36 in their middle regions, that sustains such a rigidity that the shape of the side faces in said regions are substantial constant as the side faces are bowed. The restrained side faces 4, 5 may have a stiffening part that passes lengthwise through the side face and possibly through the t adjacent corners. This will have the effect that the flexible faces will behave as rigid affixed in their ends. The stiffening part 36 of the flexible side faces is attached to drag beams 6, 7 in an actuating mechanism 43. The actuating mechanism comprises pull/push bars 14, 15, 16, 17 that via link arms 23, 24, 25, 26 are connected with swingable force transmitting plates 27, 28 swung by means of an actuator. The actuator may be provided with an external or an internal position sensor, and by means of a PLC programme and a servo valve the flexure may be controlled according to a pre-defined scheme of flexure. The outside of the casting mould may suitable be provided with a simplified and improved cooling system comprising a coolant jacket 39, that may be made out of a plastics profile or an aluminium profile attached to the mould wall 42.

Abstract

Equipment for continuous casting of strands of metals, preferentially ingots of aluminium. The equipment comprises a flexible casting mould 1 that may be rectangular with two side faces 4, 5 restrained against movement and two flexible side faces 2, 3. The flexible side faces are provided with a stiffening part 36 in their middle regions, that sustains such a rigidity that the shape of the side faces in said regions are substantial constant as the side faces are bowed. The restrained side faces 4, 5 may have a stiffening part that passes lengthwise through the side face and possibly through the adjacent corners. This will have the effect that the flexible faces will behave as rigid affixed in their ends. The stiffening part 36 of the flexible side faces is attached to drag beams 6, 7 in an actuating mechanism 43. The actuating mechanism comprises pull/push bars 14, 15, 16, 17 that via link arms 23, 24, 25, 26 are connected with swingable force transmitting plates 27, 28 swung by means of an actuator. The actuator may be provided with an external or an internal position sensor, and by means of a PLC programme and a servo valve the flexure may be controlled according to a pre-defined scheme of flexure. The outside of the casting mould may suitably be provided with a simplified and improved cooling system comprising a coolant jacket 39, that may be made out of a plastics profile or an aluminium profile attached to the mould wall 42.

5 **Equipment for continuous casting of metals**

The present invention relates to an equipment for continuous casting of strands of metals, preferably ingots of aluminium, comprising a flexible mould.

10 The casting of rectangular ingots commonly implies the use of moulds where the widest faces of the mould have a concave curvature. Such curvature is necessary to compensate for the shrinkage in the side surfaces under the casting operation. The amount of shrinkage will be proportional with the extension of the non-frozen metal in the strand after casting conditions are stabilised. During the casting of large ingots, the
15 extension of melted metal in the lengthways direction of the ingot (marsh-depth) may be up to 0,8 meters.

It is primarily the casting speed that influences the extension of the marsh, because it is the thermal conductivity of the material that limits the cooling speed in the middle of the
20 strand. The amount of water that is sprayed onto the surface of the ingot from the underside of the casting mould will represent a cooling capacity that goes beyond the amount of heat that is transported to the surface by heat conduction.

With respect to both metallurgy and productivity it is desirable to apply the highest
25 casting speed possible. The casting speed is normally limited by the tendency of heat crack formation in the strand casted when the speed is too high.

In the initial stage of a casting operation the cooling will be slow and there will be a contraction in the strand casted caused by the difference in specific density between the
30 melted and the frozen metal, together with the thermal coefficient of expansion. The metal that has frozen initially, will be of a somewhat reduced shape with respect to the geometry of the casting mould. Because of the above mentioned curvature of the widest faces of the casting mould, the strand casted will have a convex shape in the initial stage

of the casting operation. The convexity will gradually reduce until stable conditions with respect to the marsh-depth in the strand casted are established.

The rolling mills specify that the rolling surfaces should be straight and planar (i.e. without any concavity/convexity in the rolling surfaces). To meet this requirement the 5 casting moulds have to be designed with an amount of flexing (curvature of the widest faces) that is related to the expected shrinkage/contraction.

The lowest part of the casting strand has a defined convex cross-cut that is commonly recognised as the butt end. The extension of the butt end is mainly determined by the 10 amount of flexing in the respective casting mould. Typically the extension may vary from 20 centimetres to 80 centimetres depending on the dimensions of the strand casted and the amount of flexing. The part of the butt end that will not satisfy the specifications of the customer has to be cut off by the ingot producer and represents a substantial part of the scrap produced in the casting process.

15

As mentioned above, it is mainly the casting speed that is decisive for the contraction, and a casting mould will therefore render an optimal ingot geometry for a certain speed. With other words, a casting mould designed for a high casting speed will produce a convex ingot when casting at a lower speed than the design speed. On the other hand, 20 a too high casting speed with respect to the designed speed will give concave rolling surfaces.

To optimise the return from the casting process and to reduce the geometrical deviations of the strands casted, there have been developed casting moulds with flexible wide 25 faces.

US patent No. 4,030,536 discloses a casting mould for continuous casting of ingots of rectangular cross-section. The narrow faces of the ingot are arranged in such a manner that their mutual distance is kept as constant as possible, while the wide faces are 30 flexible. As the casting speed increases, the distance between the middle parts of the wide faces is gradually increased. According to the example disclosed, the distance between the wide faces of the mould is adjusted by means of a flexing mechanism comprising a manually-actuating screw jack device 16 arranged at the outside of each wide face. Each screw jack device is at its one end connected with a rigid frame section

26625-241

3

at the outside of the mould, and at its other end connected by means of a yoke and two hinged connections with the wide face of the mould. This attachment of the yoke will cause that the inner surface of the mould will have an even,
5 concave shape as the jack is tensioned. Thus, the maximum value of the distance between the wide surfaces of the mould will be apparent between the hinged connections at each side. The presented solution further comprises a cooling system that chills the strands as they are casted. The
10 cooling system comprises an upper and a lower channel for coolant water surrounding the mould at a little distance from the same, where the channels have orifices that sprays coolant water respectively towards the walls of the mould and the strand casted.

15 One disadvantage with this embodiment is that it requires an active follow-up by the operators for the control of the mould flexure versus the changes of casting speed, if the part rejected should not become too comprehensive. One another disadvantage with this solution
20 is that the even, convex shape of the wide faces contributes to the rejection of at least one first part of the ingot casted because it does not satisfy the required tolerances set by the customer.

With the equipment according to the present
25 invention, the amount rejected may be reduced to a minimum. This is achieved as the equipment includes an improved

26625-241

3a

casting mould with a flexing mechanism that gives an optimal flexure versus casting speed. At the same time the equipment is simple in use and little space demanding.

According to the invention there is provided an apparatus for continuous casting of strands of metal, comprising: a casting mould having a first pair of side faces restrained against movement and a second pair of side faces adapted for flexing by a flexing mechanism, each of said second pair of side faces including a middle region having a specified shape; and each of said second pair of side faces including a stiffening part in said middle region, wherein said stiffening part sustains rigidity of each of said second pair of side faces during flexing such that said specified shape of said middle region is maintained substantially constant.

The invention shall now be further described with reference to embodiment and enclosed drawings where:

Fig. 1 shows an equipment for continuous casting of metals, comprising a casting mould according to the invention,

- Fig. 2 shows the casting mould as shown in Figure 1 in perspective
- Fig. 3 shows the flexing of a casting mould of known type and of a casting mould according to the present invention,
- 5 Fig. 4 shows one semi-part of the casting mould as shown in Figure 1 having a coolant jacket affixed thereto,
- Fig. 5 shows a cut A-A through the casting mould as shown in Figure 4,
- Fig. 6 shows the flexure of a mould according to the present invention, at two different casting speeds (v).

10 Figure 1 shows a rectangular casting mould 1 with two wide faces 2, 3, and two narrow faces 4, 5. The wide faces 2, 3 are at their middle regions attached to drag beams 6, 7 arranged in parallel with the wide faces of the mould and forming parts of a flexing mechanism 43. The drag beams 6, 7 are of a greater extension than the outer measures of the casting mould 1, and are at their ends attached to pull-/push bars 14, 15, 16, 17 by
15 means of friction grip or clamping devices 10, 11, 12, 13. The pull-/push bars are arranged in parallel with the narrow sides of the mould and is adapted for axial movement by means of slide bearings (left side of the figure) 18, 19, 20, 21 together with an actuating mechanism 22.

The actuating mechanism 22 comprises link arms 23, 24, 25, 26 arranged between the
20 pull-/push bars 14, 15, 16, 17 and swingable force transmitting plates 27, 28 that may be swung by means of an actuator 29 affixed to a stationary frame part (not shown). In the example shown the force transmitting plates 27 and 28 are provided with respective swing axis 30 and 31. The axis are affixed to a stationary frame part (not shown). The force transmitting plate 27 is directly connected with the actuator 29 by means of a link
25 connection 35, while the force transmitting plate 28 is swung by means of a force transmitting rod 32. The rod 32 is provided with link connections 33, 34 at its ends that further are connected with the force transmitting plates 27 and 28.

The transmission ratio of the actuating mechanism is defined by the arms of lever
30 between the various link connections and the bearing axis of the force transmitting plates 27 and 28.

The actuator may suitable be a hydraulic piston/cylinder actuator with an internal position sensor. By means of a PLC programme and a servo valve (or proportional valve) the movement of the piston rod may be controlled according to a pre-defined pattern (not

further shown). This features make it possible to display a curve representing the flexure (both programmed and real values) on a digital screen forming part of an operator panel.

By controlling the movements of the piston rod it is possible to control the flexing of the 5 mould faces within a narrow interval of tolerances, thus obtaining casted strands of little deviations with respect to nominal geometrical measures. The piston rod may be positioned with a degree of accuracy corresponding to $\pm 0,2$ mm and when having a transmission ratio corresponding to 4:1 in the actuating mechanism this will correspond to $\pm 0,05$ mm of the mould width.

10

Figure 2 shows a casting mould 1 in perspective. The mould may be manufactured out of an aluminium profile that is bent and joined by a weld. Succeeding this operation, the mould may possibly pass through a heat treatment. The profile is T-shaped and the stiffening part is partly removed before bending, but a limited part 36 in the middle region 15 of the wide faces 2, 3 that will serve to stiffen these regions, is maintained. In addition, the stiffening parts in the regions forming the narrow faces 4, 5 of the mould after the bending operation is fulfilled, is maintained too.

Suitable, the stiffening parts 46 of the narrow faces 4,5 are formed in a manner that they 20 pass through the corners of the mould and possibly they protrude a little into the wide faces of the mould. Thus, these parts of the mould will also be provided with stiffening parts 47, 48. This will result in a limitation of the deformation of the wide faces at their ends as they will behave as rigid affixed at their ends. This is advantageous with respect to the desired deformation of the casting mould, together with a sealed adaptation of a 25 cooling system as described in connection with Figure 4 and 5. The extension of the stiffening part 36 will depend on the ratio between the width and the thickness of the casting mould. This will be further described in connection with the description of Figure 3.

30 The narrow faces of the casting mould are restricted against movement as they are affixed by bolts to a surrounding, stationary frame (not shown). The wide faces 2, 3 of the mould are affixed to the drag beams 6, 7, by means of the stiffening parts 36. Affixing the wide faces to the drag beams in this manner makes it possible to omit the use of affixing bolts in the mould wall. Further, this affixment serves to give a reduction

in the angular deviation of the mould wall versus the casting direction when the wide faces are flexed. This is achieved as the stiffening parts 36 are affixed to the drag beams by bolts having their length axis in parallel with the direction of casting, thereby obtaining a connection that sustains a high torsional stiffness.

5

The actuator as described in the present embodiment is of a hydraulic type, but alternatively pneumatic or electro-mechanical actuators may be used as well. The reading of the position may alternatively be carried out by a position sensor arranged in connection with one of the force transmitting plates or arranged at another adequate
10 place.

Figure 3 shows the flexure of an upper and a lower casting mould, where the upper represents a known type as for instance the one described in US 4,030,536, and the lower corresponds to the mould according to the present invention.

15 As seen in the Figure, the wide faces of the last mentioned mould will be planar in the regions of the stiffened middle parts 36 together with their ends, while the mould of known type will sustain an even deformation all over its wide faces.

Concerning casting moulds having a width/thickness ratio greater than 1,5, it is by
20 computations and experiments established a formula that may be applied in the determination of the distance between the narrow sides and the stiffened part 36 of the wide faces;

$$25 \quad a = B \left[\frac{1,33}{\frac{B}{T}} - \frac{1,27}{\left(\frac{B}{T}\right)^3} - \frac{0,2}{\left(\frac{B}{T}\right)^4} \right]$$

where a corresponds to the distance from the narrow faces to the point where the stiffening part begins, B corresponds to the width of the strand and T corresponds to the thickness of the strand.

The length l of the stiffening part is given by the expression;
30

$$l = B - 2a \quad \text{or,}$$

$$l = B \left[1 - \frac{2,66}{\frac{B}{T}} - \frac{2,54}{\left(\frac{B}{T}\right)^3} - \frac{0,4}{\left(\frac{B}{T}\right)^4} \right]$$

The optimum value of α appears to be mainly independent versus casting parameters and type of alloy.

5 The affixment of the flexing means together with the deformation of the mould walls according to the invention, make possible the adaptation of a simplified and improved cooling system, as shown in Figure 4 and 5.

Figure 4 shows a semi-part of the casting mould 1 as shown in Figure 1, where the
10 mould has attached a coolant jacket 39 thereto. Figure 5 shows a cut A-A through the casting mould 1 as shown in Figure 4. The coolant jacket 39 as shown in the Figures is made out of a profile of a material having little resistance against bending, such as for instance plastics or aluminium, and is attached to the mould wall 42 by means of bolts 37 and clamps 38. The fact that the casting mould is made out of a T-shaped profile as
15 mentioned above, render possible the attachment of the coolant jacket below the stiffening parts 36, 46, 47 of the mould, and further that the jacket is well adapted to follow the deformations of the mould.

The coolant jacket has a channel 44 for the transport of water at the outside of the
20 mould. The channel 44 may in a reasonable manner be connected with a supply of coolant water (not shown). From the channel 44 coolant water is led through a plurality of small openings to a second channel 45 that is limited by the coolant jacket 39 and the mould wall 42, and that serves as a primary cooling of the mould wall. Coolant water is led from the channel 45 through bores 41 drilled through the mould wall 42 in such a
25 manner that water is sprayed onto the strand casted (not shown) at an angle of approximately 20 degrees.

Figure 6 shows the flexure at two different casting speeds, as the alloy casted were quite identical. In this case it was applied a casting mould having a width of 1,56 meters and a
30 thickness of 0,6 meters. The horizontal axis represents the time after the bottom of the casting mould (casting shoe) starts to move, while the vertical axis represents the flexure of one mould face in millimetres. The dotted curve represents a casting speed of 75 mm/minute, while the fully drawn curve represents a speed of 55 mm/minute. As will be seen in the Figure, the final flexure (the stationary flexure) is largest for the case involving the highest casting speed.

The PLC programme controlling the flexure may be run on the basis of theoretical/empirical values that are established for the different types of alloys, width-/thickness ratio of casting moulds and casting speeds.

5

Experiments that were carried out with a casting equipment according to the present invention, involving casting strands of different alloys at different casting conditions and flexures, have shown that it is now possible to obtain substantial reductions of the parts rejected, together with the fact that the flexure of the mould now may easily be adjusted 10 in accordance with the casting speeds required for the different alloys.

15

20

25

30

26625-241

9

CLAIMS:

1. An apparatus for continuous casting of strands of metal, comprising:

5 a casting mould having a first pair of side faces restrained against movement and a second pair of side faces adapted for flexing by a flexing mechanism, each of said second pair of side faces including a middle region having a specified shape; and

10 each of said second pair of side faces including a stiffening part in said middle region, wherein said stiffening part sustains rigidity of each of said second pair of side faces during flexing such that said specified shape of said middle region is maintained substantially constant.

15 2. The apparatus of claim 1, wherein said stiffening part of each of said second pair of side faces has a length l , said second pair of side faces has a length β , and said first pair of side faces has a length T , wherein when said casting mould has a ratio of length β to length T greater than 1.5, the length l of each of said stiffening parts of
20 each of said second pair of side faces can be determined according to the following formula:

$$l = B \left[1 - \frac{2.66}{\frac{B}{T}} - \frac{2.54}{\left(\frac{B}{T}\right)^3} - \frac{0.4}{\left(\frac{B}{T}\right)^4} \right]$$

3. The apparatus of claim 2, wherein each of said
25 first pair of side faces includes a stiffening part and

26625-241

10

adjacent corners, said stiffening part of each of said first pair of side faces passing lengthwise along each of said first pair of side faces.

4. The apparatus of claim 2, wherein said casting
5 mould has a T-shaped profile, said casting mould being formed by bending and welding said profile, said T-shaped profile being modified such that a stiffening part remains only in said middle region of each of said second pair of side faces and along each of said first pair of side faces.
- 10 5. The apparatus of claim 2, further comprising drag beams intended to form part of the flexing mechanism, each of said second pair of side faces being affixed by said stiffening part of each of said second pair of side faces to said drag beams.
- 15 6. The apparatus of claim 2, further comprising mould walls of said casting mould and a cooling system including a coolant jacket ached to an exterior portion of said mould walls.
- 20 7. The apparatus of claim 1, wherein said casting mould has a T-shaped profile, said casting mould being formed by bending and welding said profile, said T-shaped profile being modified such that a stiffening part remains only in said middle region of each of said second pair of side faces and along each of said first pair of side faces.
- 25 8. The apparatus of claim 7, further comprising drag beams intended to form part of the flexing mechanism, each of said second pair of side faces being affixed by said stiffening part of each of said second pair of side faces to said drag beams.

26625-241

11

9. The apparatus of claim 7, further comprising mould walls of said casting mould and a cooling system including a coolant jacket attached to an exterior portion of said mould walls.

5 10. The apparatus of claim 1, further comprising drag beams intended to form part of the flexing mechanism, each of said second pair of side faces being affixed by said stiffening part of each of said second pair of side faces to said drag beams.

10 11. The apparatus of claim 10, further comprising mould walls of said casting mould and a cooling system including a coolant jacket attached to an exterior portion of said mould walls.

12. The apparatus of claim 10, further comprising
15 push/pull bars attached to said drag beams, and an actuating mechanism for moving said push/pull bars axially.

13. The apparatus of claim 12, further comprising
mould walls of said casting mould and a cooling system
including a coolant jacket attached to an exterior portion
20 of said mould walls.

14. The apparatus of claim 12, further comprising an actuator, said actuating mechanism including swingable force transmitting plates connected to said push/pull bars by link arms and capable of being swung by said actuator.

25 15. The apparatus of claim 14, further comprising mould walls of said casting mould and a cooling system including a coolant jacket attached to an exterior portion of said mould walls.

26625-241

12

16. The apparatus of claim 14, wherein said actuator includes a position sensor and a PLC program for controlling said actuator according to a pre-defined scheme for flexure of said second pair of side faces.

5 17. The apparatus of claim 16, wherein said actuator is hydraulic and controlled by a servo valve.

18. The apparatus of claim 16, further comprising mould walls of said casting mould and a cooling system including a coolant jacket attached to an exterior portion
10 of said mould walls.

19. The apparatus of claim 1, further comprising mould walls of said casting mould and a cooling system including a coolant jacket attached to an exterior portion of said mould walls.

15 20. The apparatus of claim 19, wherein said coolant jacket is formed of a material having minimal resistance to bending.

21. The apparatus of claim 20, wherein said material is selected from the group consisting of plastic and
20 aluminum.

22. The apparatus of claim 19, wherein said coolant jacket includes a first channel for transportation and distribution of coolant around said casting mould, and a second channel defined by said coolant jacket and said mould
25 walls, said second channel communicating with said first

26625-241

13

channel through a plurality of openings such that coolant is led from said first channel to said second channel and from said second channel to a by bores arranged in said mould walls.

5 23. The apparatus of claim 1, wherein each of said first pair of side faces includes a stiffening part and adjacent comers, said stiffening part of each of said first pair of side faces passing lengthwise along each of said first pair of side faces.

10 24. The apparatus of claim 23, further comprising mould walls of said casting mould and a cooling system including a coolant jacket attached to an exterior portion of said mould walls.

15 25. The apparatus of claim 23, further comprising drag beams intended to form part of the flexing mechanism, each of said second pair of side faces being affixed by said stiffening part of each of said second pair of side faces to said drag beams.

20 26. The apparatus of claim 23, wherein said casting mould has a T-shaped profile, said casting mould being formed by bending and welding said profile, said T-shaped profile being modified such that a stiffening part remains only in said middle region of each of said second pair of side faces and along each of said first pair of side faces.

27. The apparatus of claim 23, wherein said stiffening part of each of said first pair of side faces further passes around each of said adjacent corners.

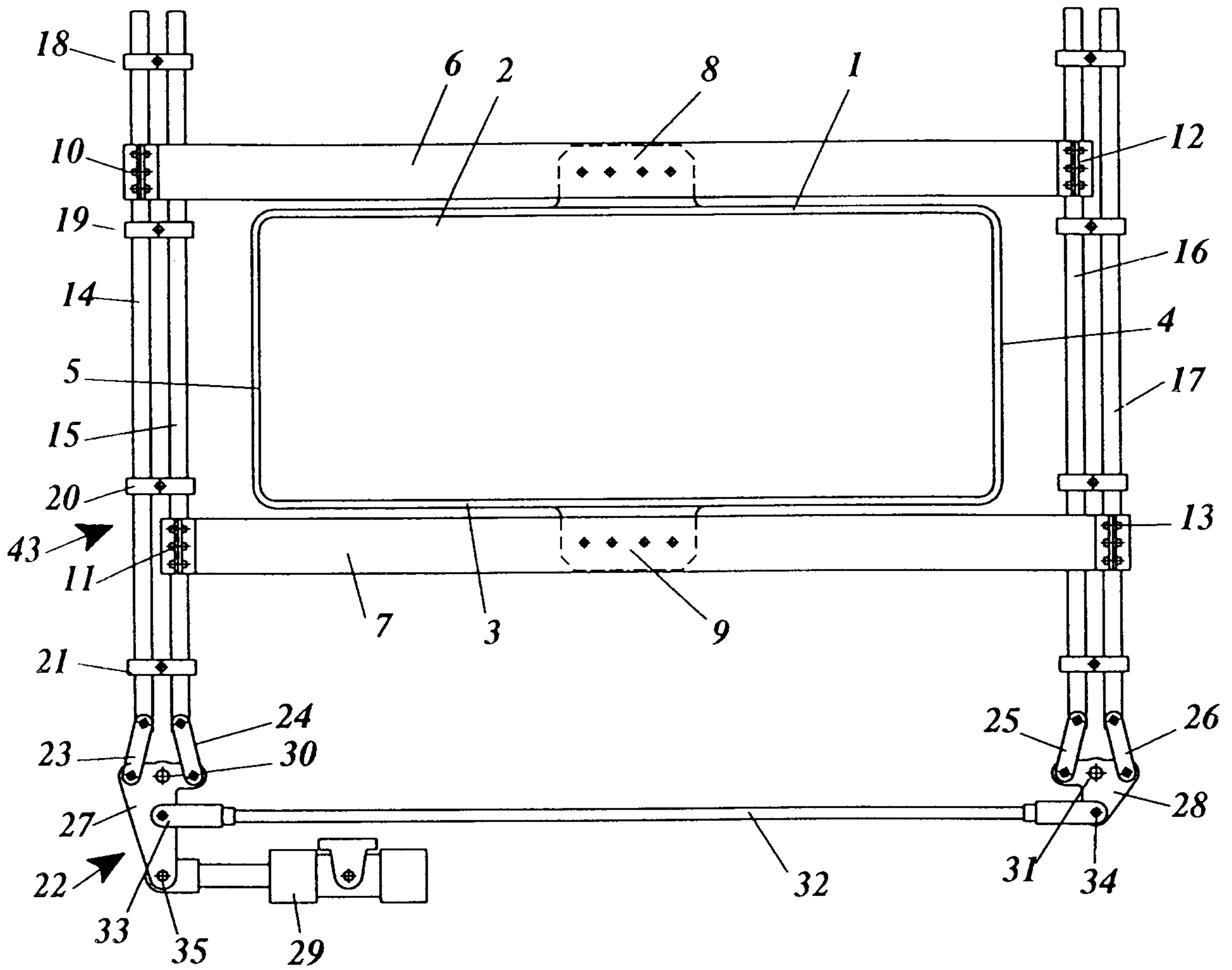

Fig. 1

Patent Agents
Fetherstonhaugh & Co.

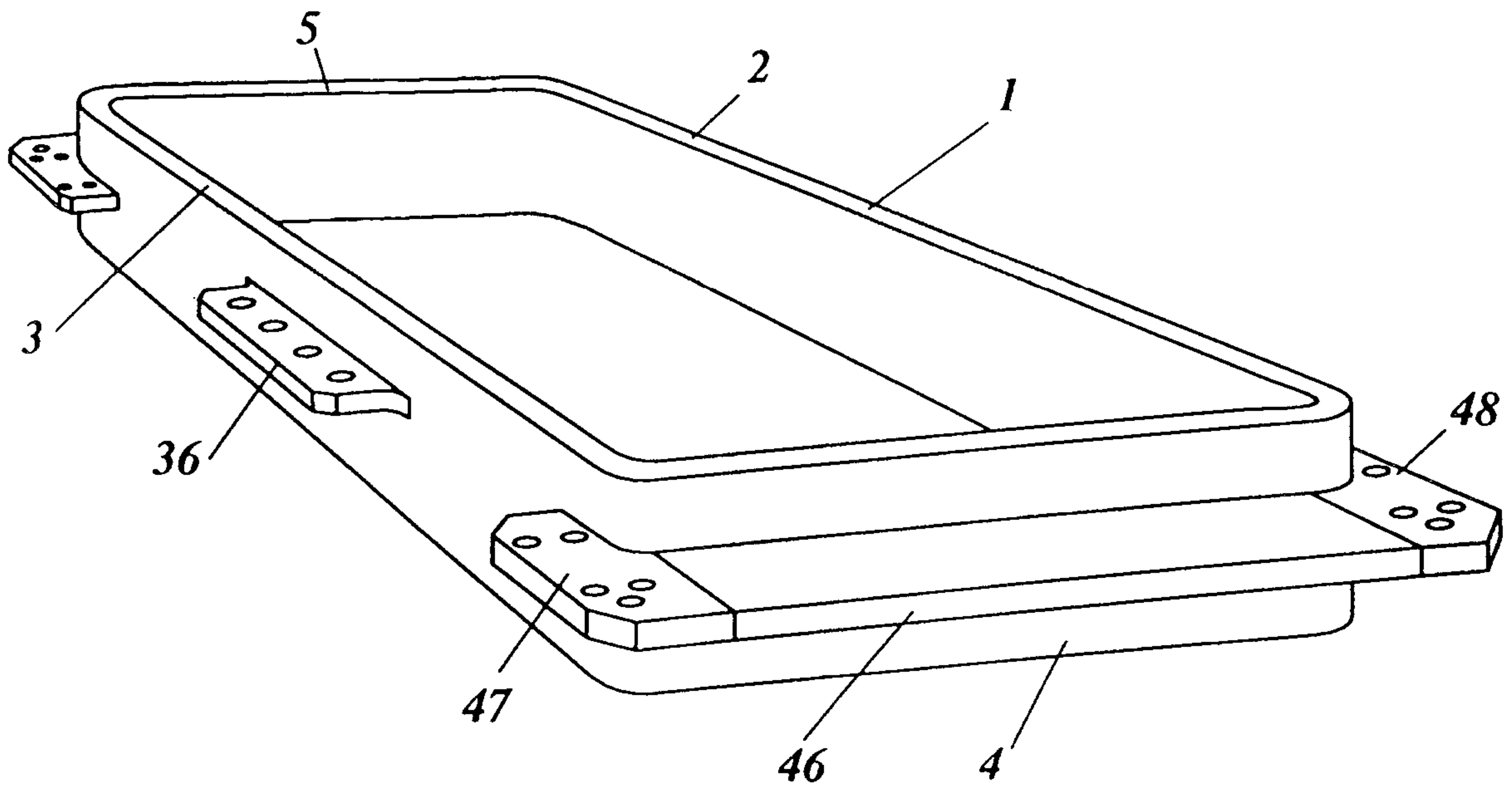

Fig. 2

Patent Agents
Fetherstonhaugh & Co.

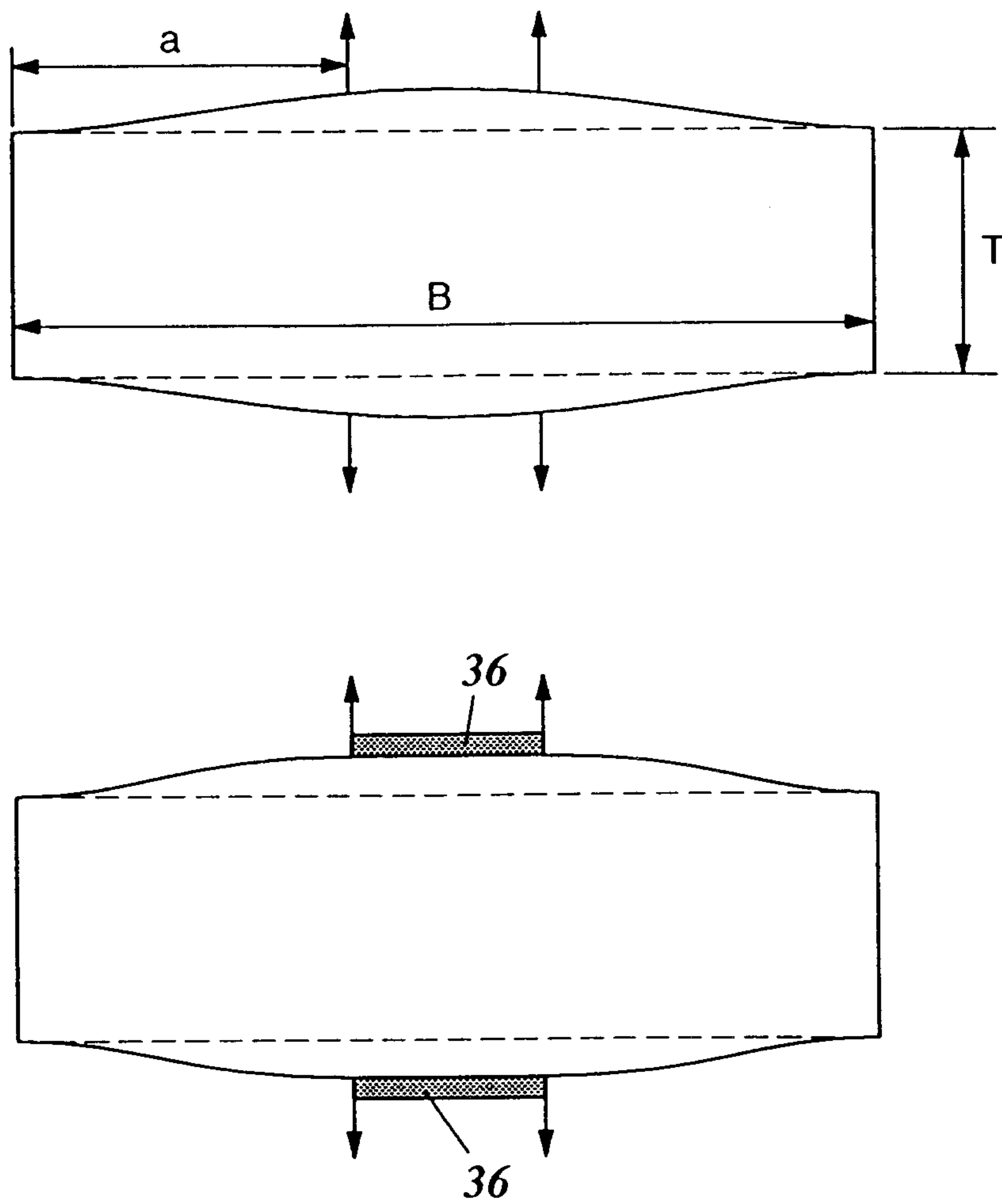

Fig. 3

Patent Agents
Fetherstonhaugh & Co.

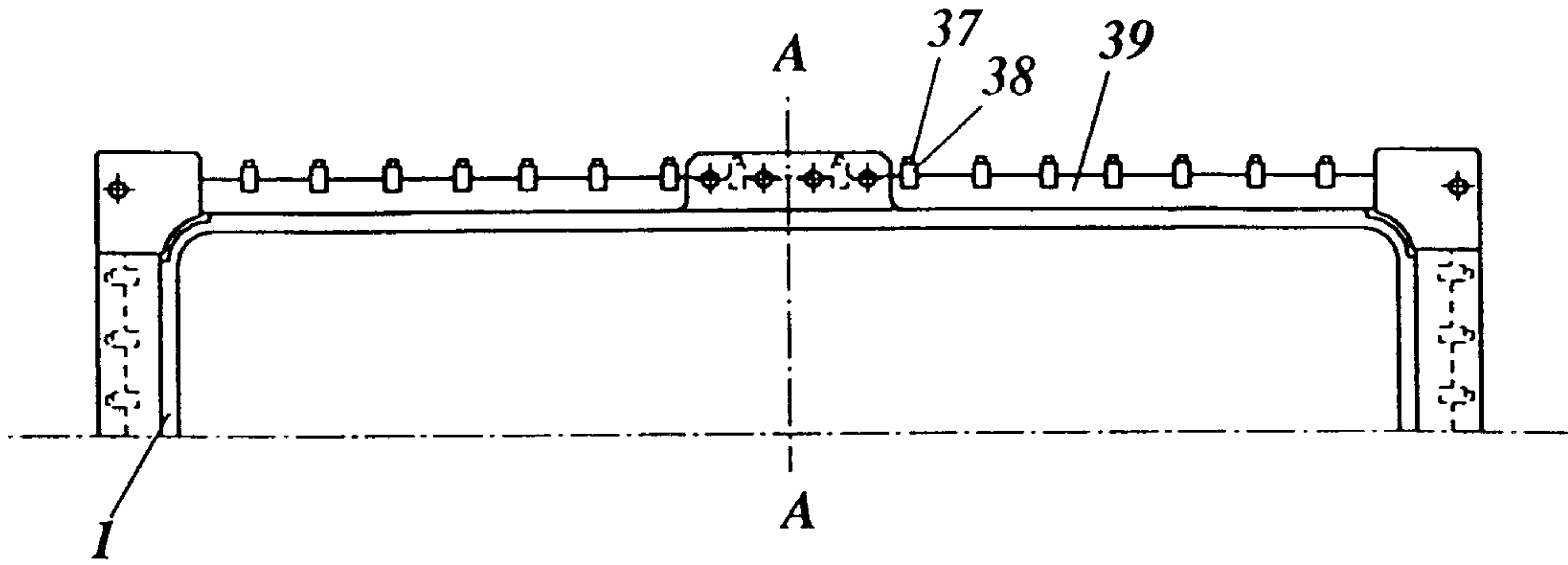

Fig. 4

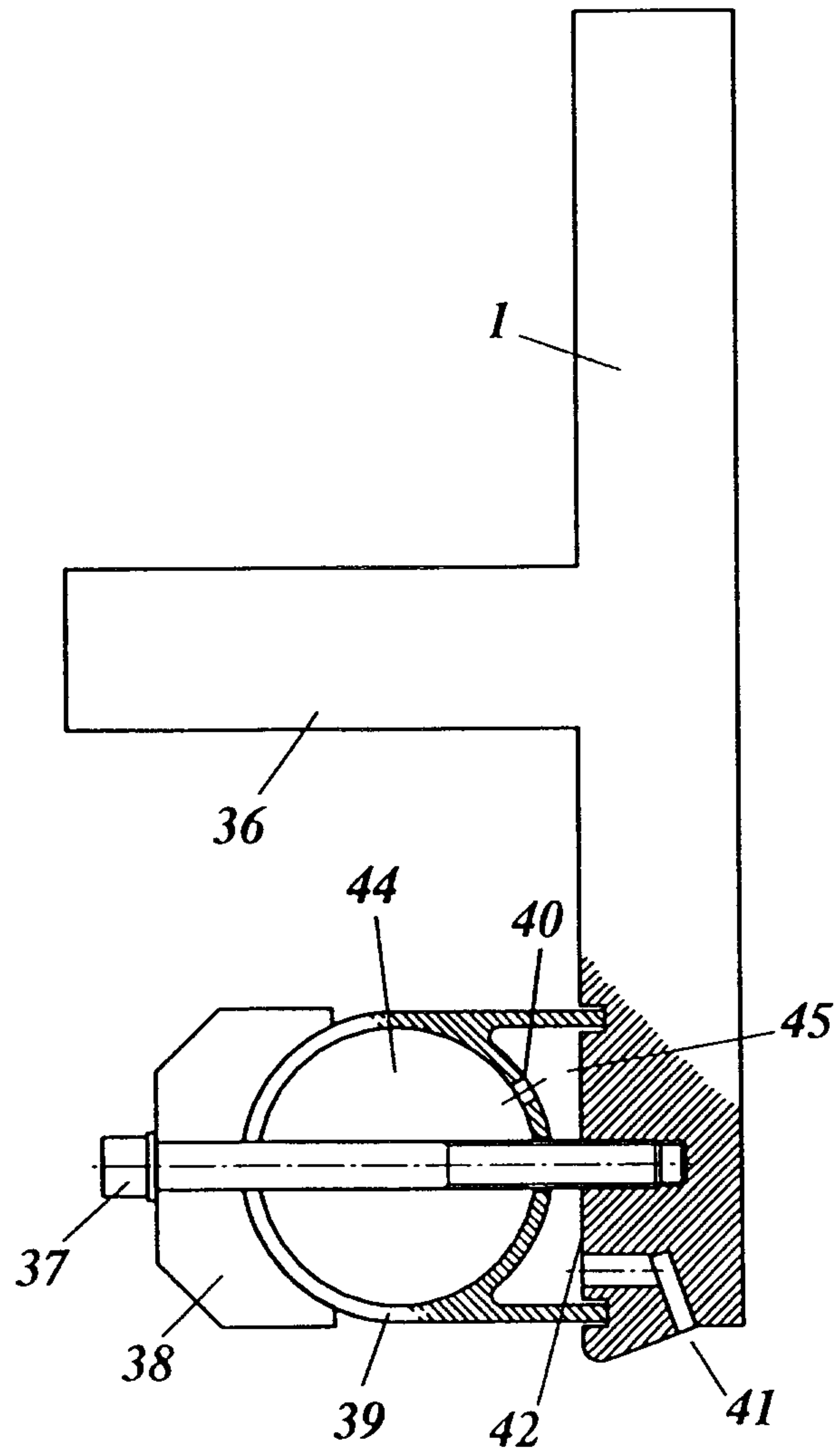
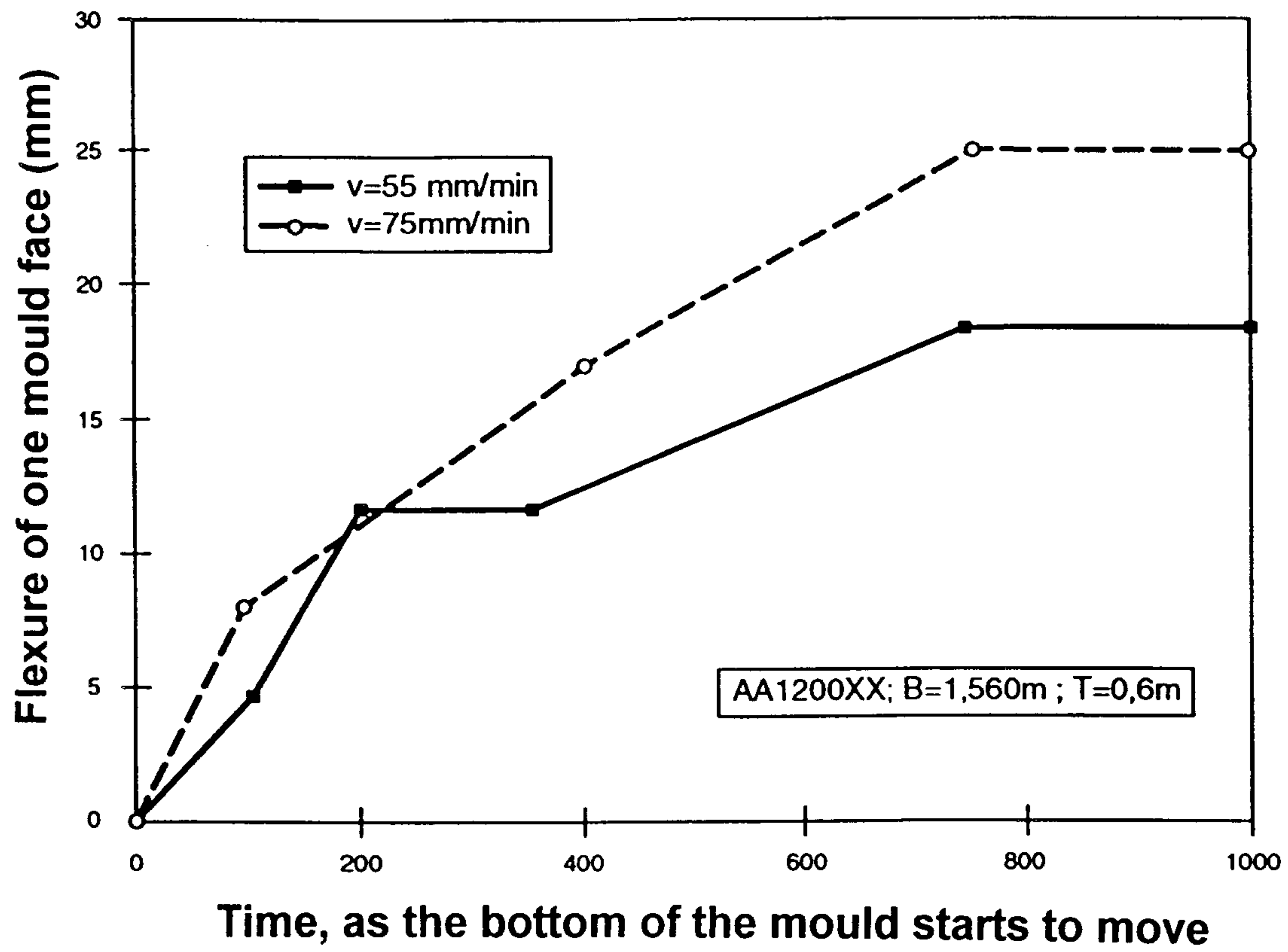

Fig. 5

Patent Agents
Fetherstonhaugh & Co.

*Fig. 6*

