



US 20160061773A1

(19) **United States**

(12) **Patent Application Publication**
BALL et al.

(10) **Pub. No.: US 2016/0061773 A1**

(43) **Pub. Date: Mar. 3, 2016**

(54) **METHOD FOR TREATING A SEMICONDUCTOR DEVICE**

Publication Classification

(71) Applicant: **LIFE TECHNOLOGIES CORPORATION**, Carlsbad, CA (US)

(51) **Int. Cl.**
G01N 27/414 (2006.01)
C11D 7/50 (2006.01)
C11D 7/34 (2006.01)
B08B 3/08 (2006.01)

(72) Inventors: **James A. BALL**, Ledyard, CT (US);
Brian REED, Guilford, CT (US)

(52) **U.S. Cl.**
CPC **G01N 27/4145** (2013.01); **B08B 3/08** (2013.01); **C11D 7/5013** (2013.01); **C11D 7/5022** (2013.01); **C11D 7/34** (2013.01)

(21) Appl. No.: **14/779,517**

(22) PCT Filed: **Mar. 28, 2014**

(86) PCT No.: **PCT/US14/32214**

(57) **ABSTRACT**

§ 371 (c)(1),

(2) Date: **Sep. 23, 2015**

Related U.S. Application Data

(60) Provisional application No. 61/806,603, filed on Mar. 29, 2013, provisional application No. 61/817,805, filed on Apr. 30, 2013.

A sensor array includes a plurality of sensors. A sensor of the plurality of sensors has a sensor pad exposed at a surface of the sensor array. A method of treating the sensor array includes exposing at least the sensor pad to a wash solution including sulfonic acid and an organic solvent and rinsing the wash solution from the sensor pad.

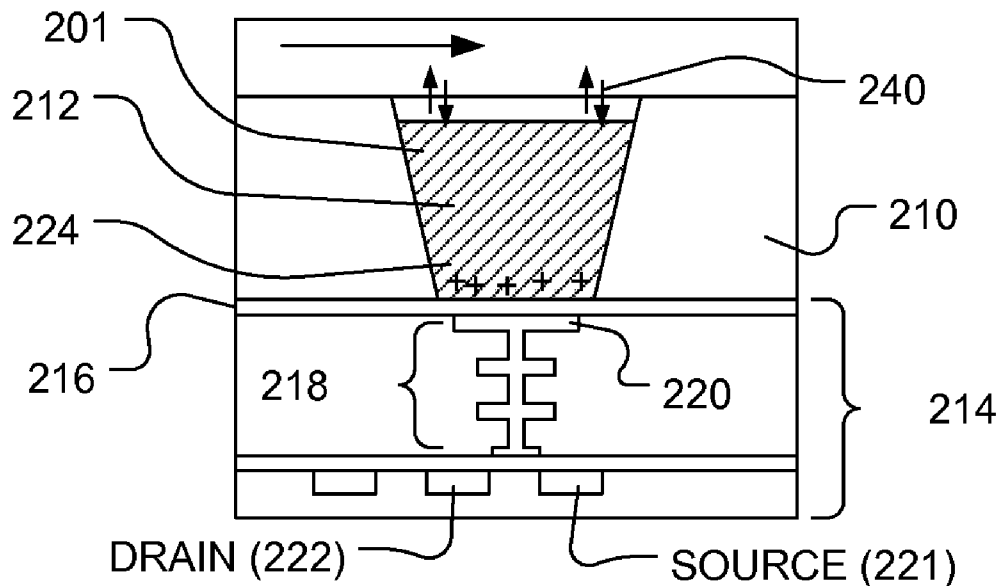

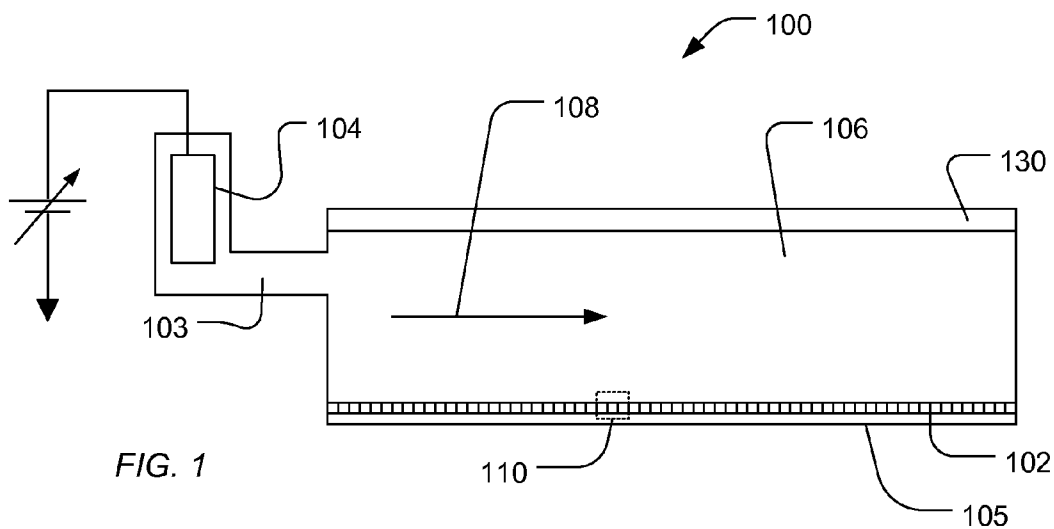

FIG. 1

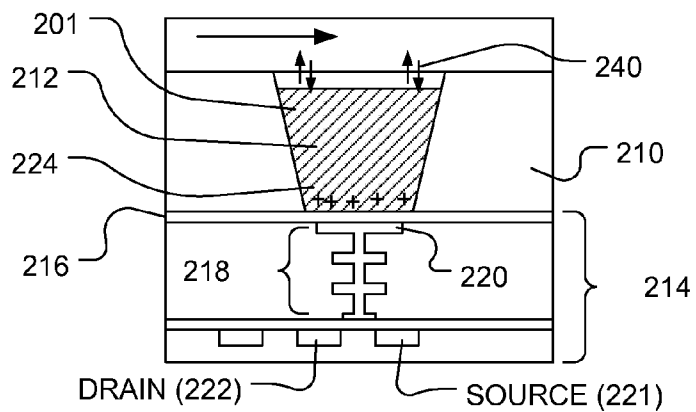

FIG. 2

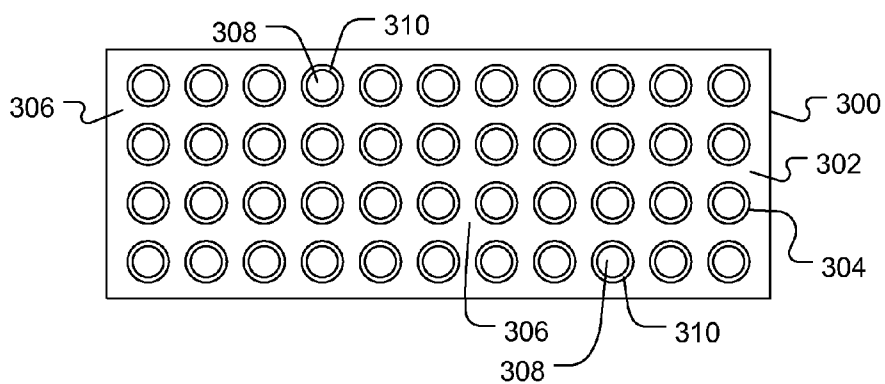

FIG. 3

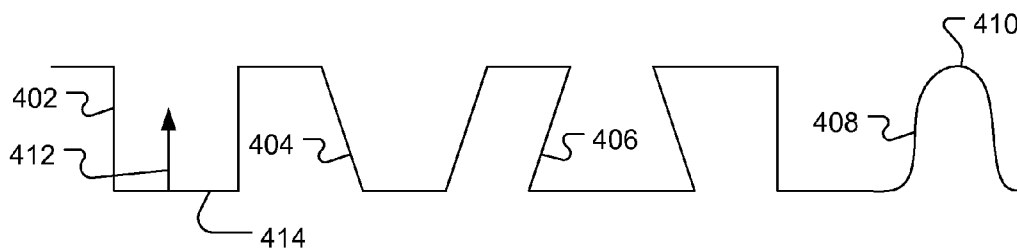

FIG. 4

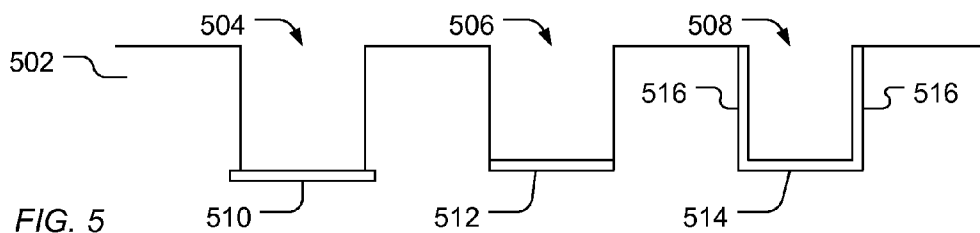

FIG. 5

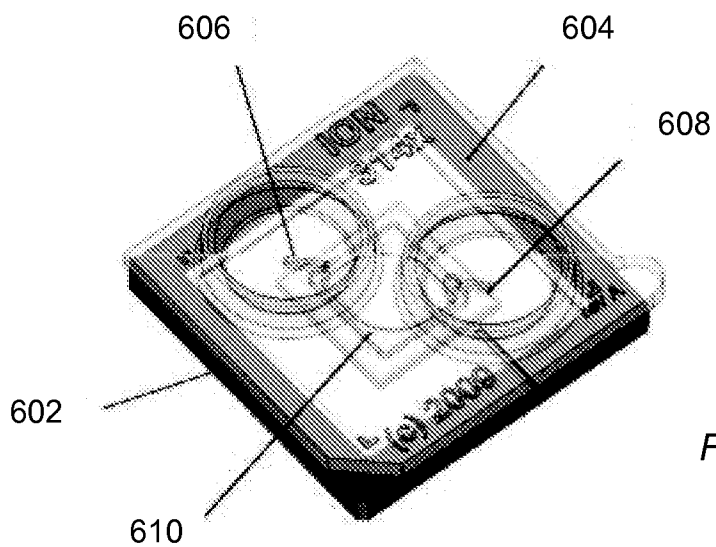

FIG. 6

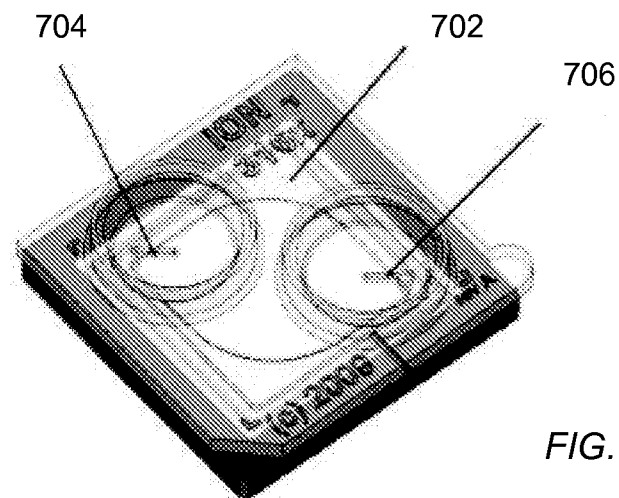

FIG. 7

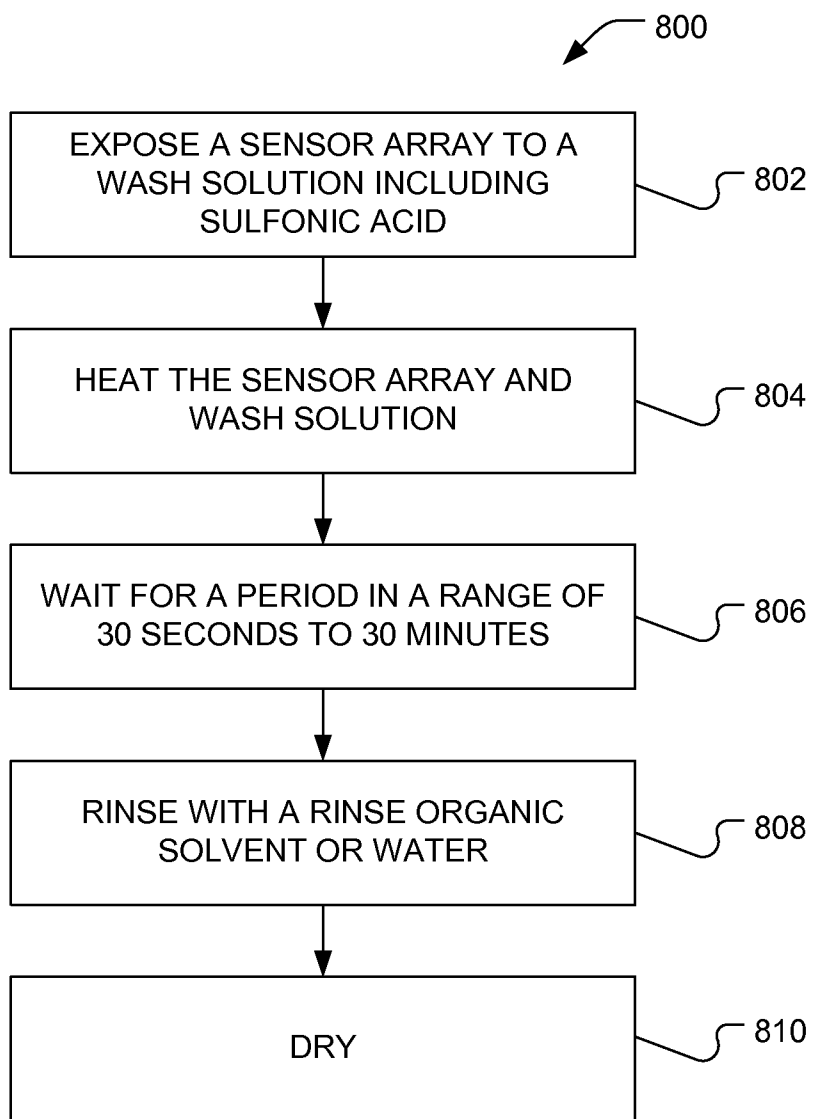

FIG. 8

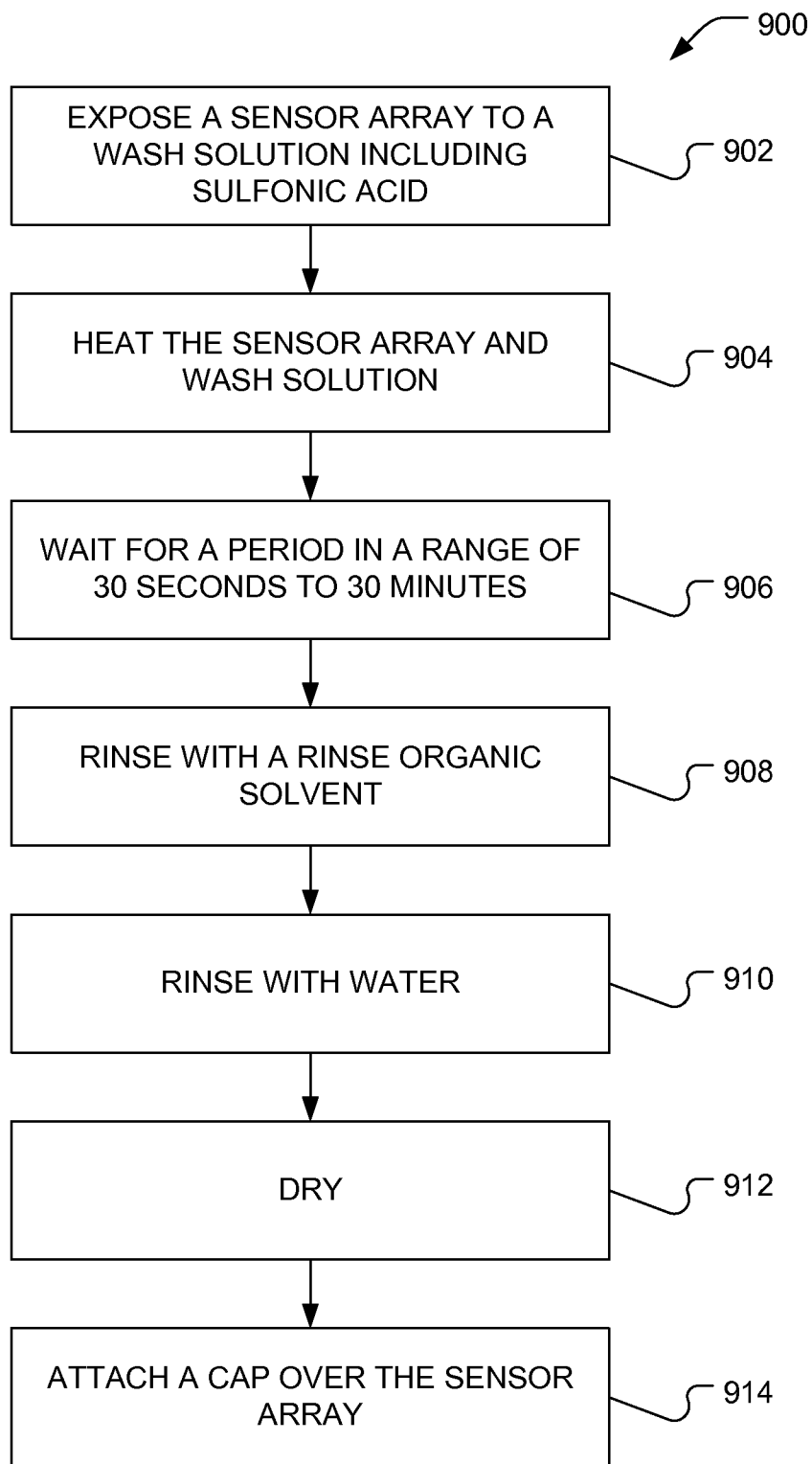

FIG. 9

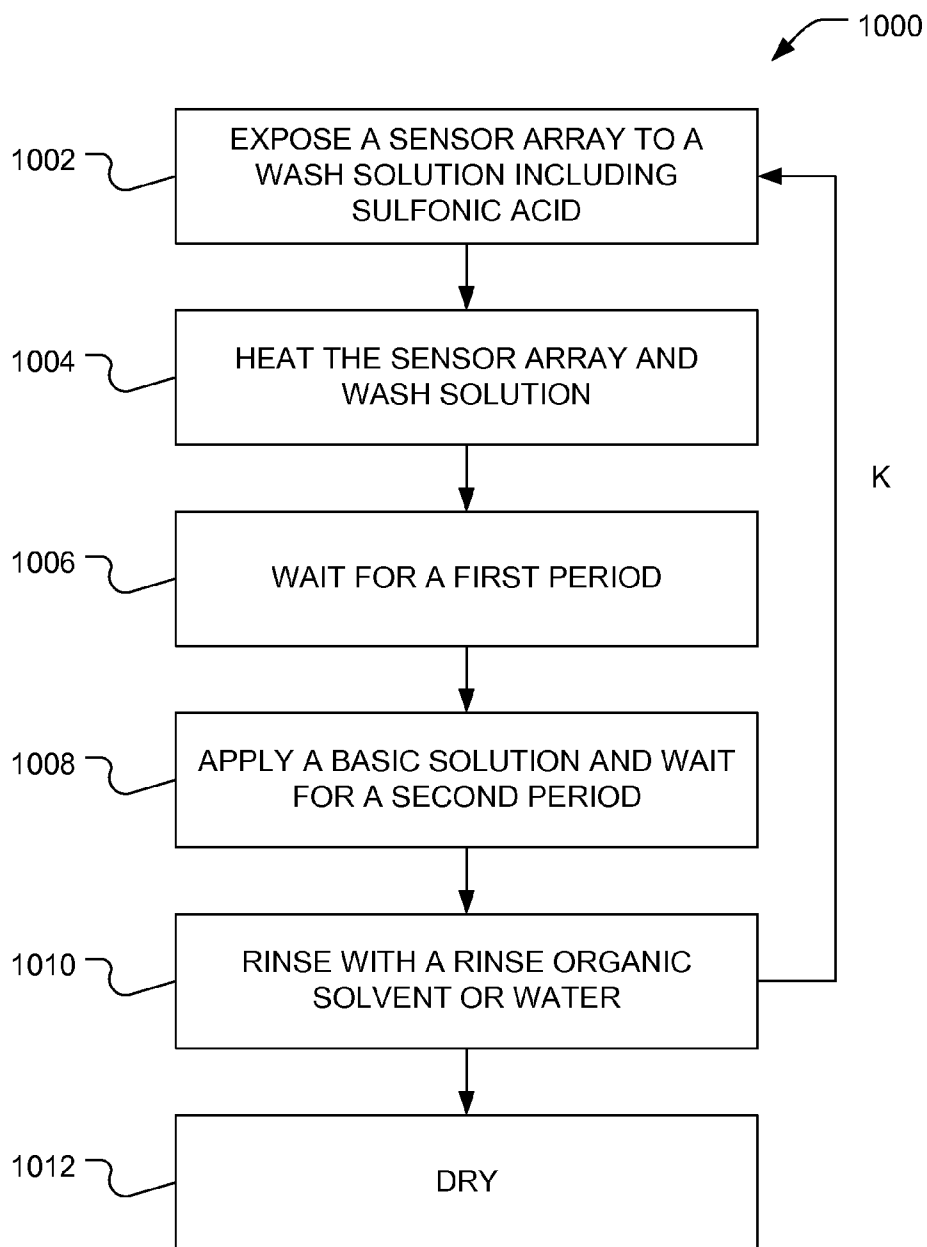

FIG. 10

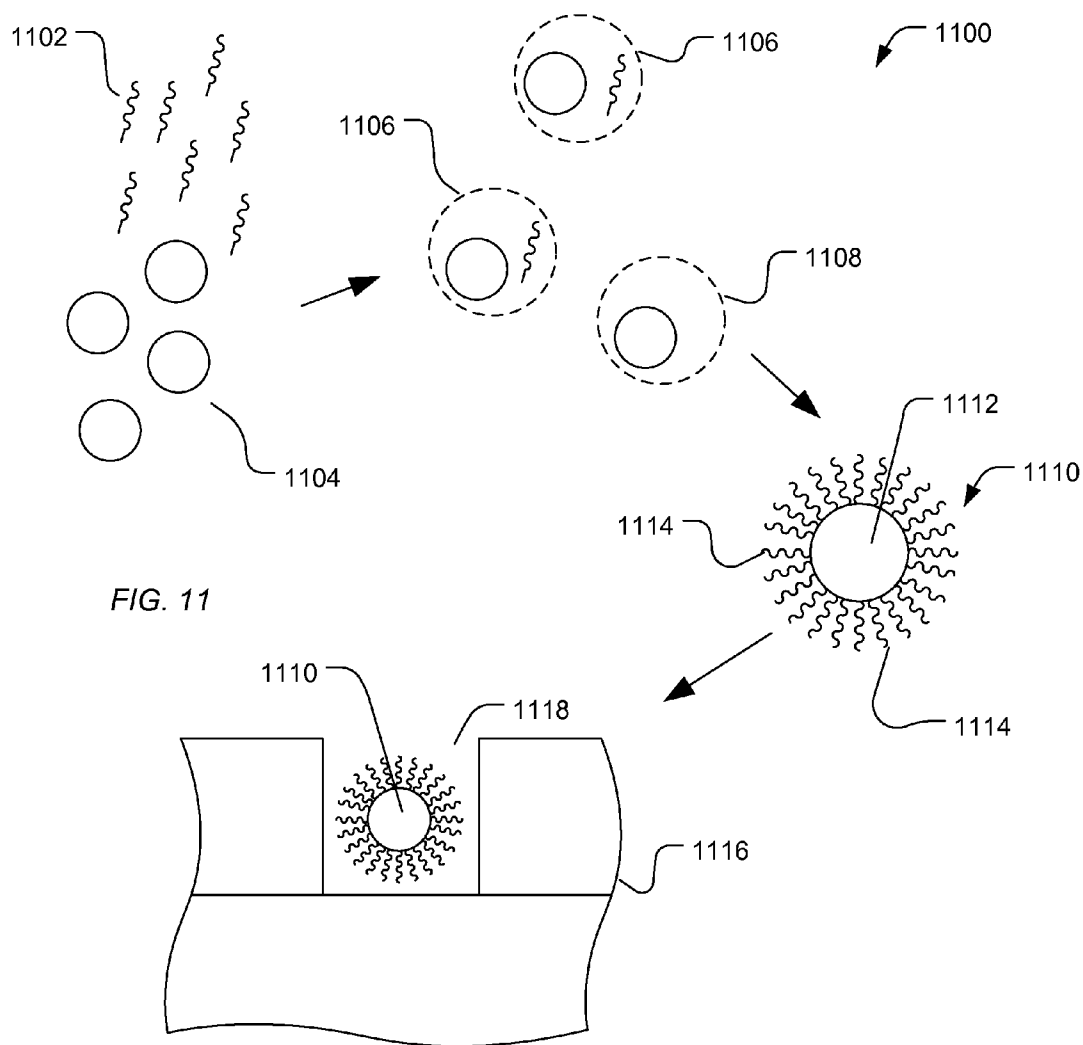

FIG. 11

METHOD FOR TREATING A SEMICONDUCTOR DEVICE

CROSS-REFERENCE TO RELATED APPLICATION(S)

[0001] This application claims benefit of U.S. Provisional Application No. 61/806,603, filed Mar. 29, 2013, which is incorporated herein by reference in its entirety.

[0002] This application claims benefit of U.S. Provisional Application No. 61/817,805, filed Apr. 30, 2013, which is incorporated herein by reference in its entirety.

FIELD OF THE DISCLOSURE

[0003] This disclosure, in general, relates to methods for treating sensor arrays, sensor arrays formed by such methods, and solutions for use in such methods.

BACKGROUND

[0004] Arrays of sensors formed in semiconductor substrates are increasingly being used in fields such as analytical chemistry and molecular biology. For example, when analytes are captured on or near sensor pads of a sensor array, the analytes or byproducts of reactions associated with the analytes can be detected and used to elucidate information regarding the analyte. In particular, such sensor arrays have found use in genetic analysis, such as genetic sequencing or quantitative amplification.

[0005] During manufacture, various semiconductor processing techniques can alter the nature of the surface of sensor array and the surface of well structures around the sensor array. Such processing can also leave residues on the surface. Altered surface chemistry or residues can prevent or limit the capture of analytes proximate to the sensors. As such, the effectiveness of such sensor arrays is reduced and signals resulting from such sensor arrays may include erroneous data or no data.

SUMMARY

[0006] In an aspect, a sensor device including a sensor array and optionally a well array corresponding to the sensor array or a cap attached over the sensor array can be treated with a wash solution. The wash solution can include an organic solvent and an acid, such as a sulfonic acid, e.g., alkyl benzene sulfonic acid. The sensor device can be further treated with a basic solution, such as a NaOH solution, or can be rinsed with a low boiling organic solvent or water. Optionally, the sensor device can be dried.

BRIEF DESCRIPTION OF THE DRAWINGS

[0007] The present disclosure may be better understood, and its numerous features and advantages made apparent to those skilled in the art by referencing the accompanying drawings.

[0008] FIG. 1 includes an illustration of an exemplary measurement system.

[0009] FIG. 2 includes an illustration of an exemplary measurement component.

[0010] FIG. 3 includes an illustration of exemplary array of measurement components.

[0011] FIG. 4 includes an illustration of exemplary well configurations.

[0012] FIG. 5 includes an illustration of exemplary well and sensor configurations.

[0013] FIG. 6 and FIG. 7 include illustrations of exemplary sensor devices.

[0014] FIG. 8, FIG. 9, and FIG. 10 include flow diagrams illustrating exemplary methods.

[0015] FIG. 11 includes an illustration of exemplary methods for preparing a sequencing device.

[0016] The use of the same reference symbols in different drawings indicates similar or identical items.

DETAILED DESCRIPTION

[0017] In an exemplary embodiment, a method of treating a sensor array includes applying a wash solution to the sensor array and rinsing the wash solution from the sensor array. In particular, the wash solution includes an organic solvent and an acid, such as a sulfonic acid. The sulfonic acid can include an alkyl or alkyl aryl sulfonic acid. In an example, the alkyl or alkyl aryl sulfonic acid can have an alkyl group having between 9 and 18 carbons. For example, the sulfonic acid can include dodecyl benzene sulfonic. The organic solvent can be a non-polar solvent or an aprotic polar solvent. In an example, the organic solvent can have a normal boiling point a range of 65° C. to 275° C. In an example, the organic solvent includes heptane. In another example, the organic solvent includes undecane. In an additional example, the organic solvent includes dimethylformamide, acetonitrile, dimethyl sulfoxide, or combinations thereof. Following treatment with the wash solution, the sensor array can be rinsed with a rinse solution. In an example, the rinse solution includes a low boiling organic solvent such as alcohol, for example, ethanol or isopropanol. In another example, the rinse solution can include water. The method may further include applying a basic solution or a weak acid solution following application of the wash solution and before rinsing. The basic solution can have a pH of at least 7, such as at least 8, and can include a strong base, such as sodium hydroxide. In an example, the wash solution and the basic solution can be applied repeatedly, such as 2 or more times, 3 or more times or even 4 or more times, but generally not greater than 10 times.

[0018] In a particular embodiment, a wash solution is applied to at least a sensor pad of the sensor array. The sensor array can include a plurality of sensors. A sensor of the sensor array can include a sensor pad. Optionally, a well structure can be defined over the sensor array and include a plurality of wells correspond with sensor pads of the sensor array. A well of the well array can expose a sensor pad of a sensor. Optionally, a cap including at least one fluid port can be disposed or attached over the sensor array and the well structure. A space for fluid can be defined between the cap and the well structure or sensor array and can be in fluid communication with the fluid port of the cap. The wash solution can be applied through the fluid port and into the space between the cap and the well structure. Optionally, a basic solution can be applied through the fluid port to the space between the cap and the well structure following application of the wash solution. Application of the wash solution followed by the basic solution can be repeated, such as at least twice or even at least 3 times. A rinse solution can be applied through the fluid port, for example, including alcohol or water. Optionally, the system can be dried.

[0019] In another exemplary embodiment, a sensor array includes a plurality of sensors. A sensor of the plurality of sensors includes a sensor pad. A well structure is disposed

over the sensor array and includes a well array that operatively corresponds with the sensor array. A well of the well array exposes a sensor pad of a sensor. The wash solution including an acid, such as a sulfonic acid, and an organic solvent can be applied to the sensor array for a period between 30 seconds and 30 min. The sensor array can be rinsed with a rinse solution. In an example, the rinse solution can include a low boiling organic solvent such as an alcohol. The sensor array can be rinsed one or more times with the low boiling organic solvent. In another example or in addition, the sensor array can be rinsed with water, such as deionized water. The sensor array can be dried and a cap can be attached over the well structure and the sensor array. The cap can include at least one fluid port. A space is defined between the cap and the sensor array or the well structure and is in fluid communication with the fluid port.

[0020] In a particular embodiment, a sensor system includes a flow cell in which a sensory array is disposed, includes communication circuitry in electronic communication with the sensory array, and includes containers and fluid controls in fluidic communication with the flow cell. In an example, FIG. 1 illustrates an expanded and cross-sectional view of a flow cell **100** and illustrates a portion of a flow chamber **106**. A reagent flow **108** flows across a surface of a well array **102**, in which the reagent flow **108** flows over the open ends of wells of the well array **102**. The well array **102** and a sensor array **105** together can form an integrated unit forming a lower wall (or floor) of flow cell **100**. A reference electrode **104** can be fluidically coupled to flow chamber **106**. Further, a flow cell cover **130** encapsulates flow chamber **106** to contain reagent flow **108** within a confined region.

[0021] FIG. 2 illustrates an expanded view of a well **201** and a sensor **214**, as illustrated at **110** of FIG. 1. The volume, shape, aspect ratio (such as base width-to-well depth ratio), and other dimensional characteristics of the wells can be selected based on the nature of the reaction taking place, as well as the reagents, byproducts, or labeling techniques (if any) that are employed. The sensor **214** can be a chemical field-effect transistor (chemFET), more specifically an ion-sensitive FET (ISFET), with a floating gate **218** having a sensor plate **220** optionally separated from the well interior by a material layer **216**. In addition, a conductive layer (not illustrated) can be disposed over the sensor plate **220**. In an example, the material layer **216** includes an ion sensitive material layer. The material layer **216** can be a ceramic layer, such as an oxide of zirconium, hafnium, tantalum, aluminum, or titanium, among others, or a nitride of titanium. In an example, the material layer **216** can have a thickness in a range of 5 nm to 100 nm, such as a range of 10 nm to 70 nm, a range of 15 nm to 65 nm, or even a range of 20 nm to 50 nm. Together, the sensor plate **220** and the material layer **216** form a sensor pad.

[0022] While the material layer **216** is illustrated as extending beyond the bounds of the illustrated FET component, the material layer **216** can extend along the bottom of the well **201** and optionally along the walls of the well **201**. The sensor **214** can be responsive to (and generate an output signal related to) the amount of a charge **224** present on material layer **216** opposite the sensor plate **220**. Changes in the charge **224** can cause changes in a current between a source **221** and a drain **222** of the chemFET. In turn, the chemFET can be used directly to provide a current-based output signal or indirectly with additional circuitry to provide a voltage-based output

signal. Reactants, wash solutions, and other reagents can move in and out of the wells by a diffusion mechanism **240**.

[0023] In an embodiment, reactions carried out in the well **201** can be analytical reactions to identify or determine characteristics or properties of an analyte of interest. Such reactions can generate directly or indirectly byproducts that affect the amount of charge adjacent to the sensor plate **220**. If such byproducts are produced in small amounts or rapidly decay or react with other constituents, multiple copies of the same analyte can be analyzed in the well **201** at the same time in order to increase the output signal generated. In an embodiment, multiple copies of an analyte can be attached to a solid phase support **212**, either before or after deposition into the well **201**. In an example, the solid phase support **212** can be a particle, such as a polymeric particle or an inorganic particle. In another example, the solid phase support **212** can be a polymer matrix, such as a hydrophilic polymer matrix, for example, a hydrogel matrix or the like.

[0024] The well **201** can be defined by a wall structure, which can be formed of one or more layers of material. In an example, the wall structure can have a thickness extending from the lower surface to the upper surface of the well in a range of 0.01 micrometers to 10 micrometers, such as a range of 0.05 micrometers to 10 micrometers, a range of 0.1 micrometers to 10 micrometers, a range of 0.3 micrometers to 10 micrometers, or a range of 0.5 micrometers to 6 micrometers. In particular, the thickness can be in a range of 0.01 micrometers to 1 micrometer, such as a range of 0.05 micrometers to 0.5 micrometers, or a range of 0.05 micrometers to 0.3 micrometers. The wells **201** can have a characteristic diameter, defined as the square root of 4 times the cross-sectional area (A) divided by Pi (e.g., $\sqrt{4A/\pi}$), of not greater than 5 micrometers, such as not greater than 3.5 micrometers, not greater than 2.0 micrometers, not greater than 1.6 micrometers, not greater than 1.0 micrometers, not greater than 0.8 micrometers or even not greater than 0.6 micrometers. In an example, the wells **201** can have a characteristic diameter of at least 0.01 micrometers.

[0025] While FIG. 2 illustrates a single-layer wall structure and a single-layer material layer **216**, the system can include one or more wall structure layers, one or more conductive layers or one or more material layers. For example, the wall structure can be formed of one or more layers, including an oxide of silicon or TEOS or including a nitride of silicon.

[0026] In a particular example illustrated in FIG. 3, a system **300** includes a well wall structure **302** defining an array of wells **304** disposed over or operatively coupled to sensor pads of a sensor array. The well wall structure **302** defines an upper surface **306**. A lower surface **308** associated with the well is disposed over a sensor pad of the sensor array. The well wall structure **302** defines a sidewall **310** between the upper surface **306** and the lower surface **308**. As described above, a material layer in contact with sensor pads of the sensor array can extend along the lower surface **308** of a well of the array of wells **304** or along at least a portion of the wall **310** defined by the well wall structure **302**. The upper surface **306** can be free of the material layer. In particular, a polymer matrix can be disposed in the wells of the array of wells **304**. The upper surface **306** can be substantially free of the polymer matrix. For example, the upper surface **306** can include an area that is free of the polymer matrix, such as at least 70% of the total area, at least 80% of the total area, at least 90% of the total area or approximately 100% of the total area.

[0027] While the wall surface of FIG. 2 is illustrated as extending substantially vertically and outwardly, the wall surface can extend in various directions and have various shapes. Substantially vertically denotes extending in a direction having a component that is normal to the surface defined by the sensor pad. For example, as illustrated in FIG. 4, a well wall 402 can extend vertically, being parallel to a normal component 412 of a surface defined by a sensor pad. In another example, the wall surface 404 extends substantially vertically, in an outward direction away from the sensor pad, providing a larger opening to the well than the area of the lower surface of the well. As illustrated in FIG. 4, the wall surface 404 extends in a direction having a vertical component parallel to the normal component 412 of the surface 414. In an alternative example, a wall surface 406 extends substantially vertically in an inward direction, providing an opening area that is smaller than an area of the lower surface of the well. The wall surface 406 extends in a direction having a component parallel to the normal component 412 of the surface 414.

[0028] While the surfaces 402, 404, or 406 are illustrated by straight lines, some semiconductor or CMOS manufacturing processes can result in structures having nonlinear shapes. In particular, wall surfaces, such as wall surface 408 and upper surfaces, such as upper surface 410, can be arcuate in shape or take various nonlinear forms. While the structures and devices illustrated herewith are depicted as having linear layers, surfaces, or shapes, actual layers, surfaces, or shapes resulting from semiconductor processing can differ to some degree, possibly including nonlinear and arcuate variations of the illustrated embodiment.

[0029] FIG. 5 includes an illustration of exemplary wells including ion sensitive material layers. For example, a well structure 502 can define an array of wells, such as exemplary wells 504, 506, or 508. The wells (504, 506, or 508) can be operatively coupled to an underlying sensor (not illustrated) or linked to such an underlying sensor. Exemplary well 504 includes an ion sensitive material layer 510 defining the bottom of the well 504 and extending into the structure 502. While not illustrated in FIG. 5, a conductive layer, such as a gate, for example, a floating gate of ion sensitive field effect transistor can reside below the ion sensitive material layer 510.

[0030] In another example, as illustrated by well 506, an ion sensitive material layer 512 can define the bottom of the well 506 without extending into the structure 502. In a further example, a well 508 can include an ion sensitive layer 514 that extends along at least a portion of a sidewall 516 of the well 508 defined by the structure 502. As above, the ion sensitive material layers 512 or 514 can reside over conductive layers or gates of underlying electronic devices.

[0031] As illustrated in FIG. 6, the sensor device can include a sensor array 602 formed within a semiconductor substrate. A well structure is defined over the sensor array. A cap 604 is attached to the well structure or the sensor array 602. For example, the cap 604 can be adhered to the sensor array or well structure 602 using an adhesive. The cap 604 includes fluid ports 606 or 608, which are in fluid communication with a flow cell 610 defined between the cap 604 and the sensor array and well array 602. Fluid applied to one of the fluid ports 606 or 608 can flow through the flow cell 610 and optionally out the other port 608 or 606. In another example illustrated in FIG. 7, a cap 702 can include fluid ports 704 and

706 and can define a larger flow space. The cap can be adhered over a well array or sensor array, for example, using an adhesive.

[0032] As illustrated in the method 800 of FIG. 8, a sensor array can be exposed to a wash solution including an acid, such as sulfonic acid, phosphonic acid, or a combination thereof, as illustrated 802. The wash solution can further include an organic solvent.

[0033] An exemplary sulfonic acid includes an alkyl sulfonic acid, an alkyl aryl sulfonic acid, or a combination thereof. An exemplary alkyl sulfonic acid includes an alkyl group having 1 to 18 carbons, such as 1 to 14 carbons, 1 to 10 carbons, or 1 to 5 carbons. In another example, the alkyl group of the alkyl sulfonic acid has 10 to 14 carbons. For example, an alkyl sulfonic acid can include methanesulfonic acid, ethanesulfonic acid, propane sulfonic acid, butane sulfonic acid, or combinations thereof. In another example, the alkyl group can be functionalized, for example, with a terminal functional group opposite the sulfonic acid functional group. An exemplary functionalized alkyl sulfonic acid includes an alkyl sulfonic acid functionalized with a terminal amine group, such as taurine. In a further example, the alkyl groups of the sulfonic acid can be halogenated, such as fluorinated.

[0034] In a further example, the sulfonic acid includes an alkyl aryl sulfonic acid. The alkyl aryl sulfonic acid, for example, alkyl benzene sulfonic acid, can include an alkyl group having between 1 and 20 carbons. For example, the alkyl group can have between 9 and 18 carbons, such as between 10 and 14 carbons. In a particular example, the alkyl aryl sulfonic acid includes dodecyl benzene sulfonic acid. The dodecyl benzene sulfonic acid can be a purified form of dodecyl benzene sulfonic acid having at least 90%, such as at least 95% of alkyl aryl sulfonic acid having an alkyl group with 12 carbons. Alternatively, the dodecyl benzene sulfonic acid can include a blend of alkyl benzene sulfonic acid having alkyl groups with an average of 12 carbons. The alkyl aryl sulfonic acid can be alkylated at a blend of positions along the alkyl chain. In another example, the alkyl group can have between 1 and 6 carbons. For example, the alkyl aryl sulfonic acid can include toluene sulfonic acid.

[0035] The wash solution can have a concentration between 10 mM and 500 mM acid, such as sulfonic acid. For example, the wash solution can have a concentration between 50 mM and 250 mM acid. In another example, the wash solution includes between 0.5 wt % and 25 wt % of the acid, such as sulfonic acid. For example, the wash solution can include between 1 wt % and 10 wt % of the acid, such as sulfonic acid, such as between 2.5 wt % and 5 wt % of the acid, such as sulfonic acid.

[0036] The organic solvent within the wash solution is a non-aqueous solvent providing solubility for the acid (e.g., sulfonic acid) to at least the concentrations above. In an example, the organic solvent can be aprotic. The organic solvent can be a non-polar organic solvent. In another example, the organic solvent can be a polar aprotic solvent. In an example, the organic solvent can have a normal boiling point in a range of 36° C. to 345° C. For example, the normal boiling point can be in a range of 65° C. to 275° C. In another example, the normal boiling point can be in a range of 65° C. to 150° C. Alternatively, the normal boiling point is in a range of 150° C. to 220° C.

[0037] In a particular example, the non-polar organic solvent includes an alkane solvent, an aromatic solvent, or a combination thereof. An alkane solvent can have between 6

and 20 carbons. For example, the alkane can have between 6 and 14 carbons, such as between 6 and 9 carbons. Alternatively, the alkane can have between 10 and 14 carbons. In a particular example, the alkane is a linear alkane. For example, the alkane solvent can include pentane, hexane, heptane, octane, decane, undecane, dodecane, or combinations thereof. In another example, the alkane is halogenated. An exemplary branched alkane can include hydrogenated dimers of C11 or C12 alpha olefins.

[0038] In a further example, the organic solvent can include a polar aprotic solvent. For example, the polar aprotic solvent can include tetrahydrofuran, ethylacetate, acetone, dimethylformamide, acetonitrile, dimethyl sulfoxide, N-methyl pyrrolidone (NMP), or combinations thereof. In another example, the organic solvent may be free of ether solvents and, for example, may include dimethylformamide, acetonitrile, dimethyl sulfoxide, or combinations thereof.

[0039] As illustrated at **804**, the wash solution and sensor device can be heated while the sensor pad is exposed to wash solution. In an example, the wash solution and the sensor device can be heated at a temperature in a range of 35° C. to 60° C. For example, the temperature can be in a range of 40° C. to 50° C.

[0040] As illustrated **806**, the sensor array can be exposed to the wash solution and optionally heated for a period in a range of 30 seconds to 30 min. For example, the period can be in a range of 30 seconds to 10 min., such as a range of 30 seconds to 5 min., or even a range of 1 min. to 2 min.

[0041] An organic solvent or water can be used to rinse the sensor array, as illustrated **808**, following exposure to the wash solution. The organic solvent can be a low boiling organic solvent. An exemplary low boiling organic solvent can have a normal boiling point range of 25° C. to 100° C., such as a normal boiling point in a range of 50° C. to 100° C. In an example, the low boiling organic solvent includes an alcohol, such as ethanol or propanol. Alternatively, the organic solvent can be N-methyl pyrrolidone (NMP). Alternatively or in addition, the sensor array can be rinsed with water, such as deionized water. In a particular example, the organic solvent is at least partially miscible with water and the organic solvent of the acid/solvent mixture.

[0042] As illustrated at **810**, the sensor array can be dried. In an example, the sensor array can be dried under an inert atmosphere, such as using dry nitrogen or helium. In another example, the sensor can be heated under a dry atmosphere. In a further example, the sensor array can be dried under vacuum.

[0043] In a further example illustrated in FIG. 9, a method **900** includes exposing a sensor array to a wash solution including an acid as described above, for example, sulfonic acid, as illustrated **902**. A sensor device can include the sensor array and optionally a well structure defining a well array operatively corresponding to the sensor array. A well of the well array can expose a sensor pad of a sensor of the sensor array. The wash solution can have the composition described above. Optionally, the sensor array and the wash solution can be heated as illustrated **904**. For example, the sensor array and the wash solution can be heated to temperatures described above.

[0044] In a further example, the sensor array can be exposed to the wash solution and optionally heated for a period in a range of 30 seconds to 30 min., as illustrated **906**.

Alternatively, the sensor array can be exposed to a wash solution and optionally heated for the time periods described above.

[0045] Following exposure to the wash solution, the sensor array can be rinsed with a solvent, e.g., a low boiling solvent, as illustrated **908**. Exemplary low boiling solvents are described above. Alternatively, the solvent can be N-methyl pyrrolidone (NMP). The sensor array can be rinsed with the low boiling solvent one time or more than one time.

[0046] Following rinsing with the low boiling organic solvent, the sensor array can be rinsed with water, such as deionized water, as illustrated at **910**. Following rinsing with water, the sensor array can be dried as illustrated **912**. For example, the sensor array can be exposed to dry nitrogen gas.

[0047] Once dried, a cap can be applied over the sensor array, as illustrated **914**. For example, the cap can be attached to the sensor array or an intervening well structure using an adhesive. In particular, the cap includes fluid ports in fluid communication with a space defined between the cap and a well structure over the sensor array. Optionally, the method can be applied to a wafer prior to separating the wafer into arrays and capping individual arrays.

[0048] In a further exemplary embodiment illustrated in FIG. 10, a method **1000** includes exposing a sensor array to a wash solution that includes acid as described above, for example, sulfonic acid, as illustrated at **1002**. The wash solution can further include an organic solvent. In particular, the sensor array can include a well structure defining an array of wells operatively corresponding to the array of sensors. A sensor pad of a sensor is exposed by a well of the well array. A cap can be attached over the sensor array or the well array. The cap includes fluid ports in communication with a space defined between the cap and the well array or sensor array. The wash solution can be applied through the fluid port into the space. The composition of a wash solution can be as described above.

[0049] Optionally, as illustrated at **1004**, the wash solution and the sensor array can be heated. For example, the wash solution and the sensor array can be heated at the temperatures described above.

[0050] The sensor array can be exposed to the wash solution and optionally heated for a first period, as illustrated at **1006**. The first period can have a range of 30 seconds to 30 min., such as the ranges of times periods described above.

[0051] In addition, a basic solution can be applied to the sensor array for a second period, as illustrated at **1008**. For example, the basic solution can be applied through a fluid port of a cap and into the space defined between the cap and the well structure or sensor array. The basic solution has a pH greater than 7, such as a pH greater than 8, or even a pH greater than 9. The basic solution includes a strong base, such as sodium or potassium hydroxide or a tetraalkyl ammonium hydroxide, such as tetramethyl ammonium hydroxide or tetraethyl ammonium hydroxide. The base is in a concentration between 0.05M and 1.5M. For example, the base can be in a concentration between 0.05M and 1.0M, such as between 0.05M and 0.5M. The sensor array can be exposed to the basic solution for a period of between 20 seconds and 15 min., such as a period of between 20 seconds and 5 min. or a period of between 30 seconds and 2 min. Alternatively, a weak acid solution can be substituted for the basic solution.

[0052] The sensor array can be exposed to the wash solution followed by exposure to the basic solution or the weak

acid repeatedly, such as k times. For example, k can be 1, 2, or 3, but generally is not greater than 10.

[0053] Following exposure to the wash solution and the basic solution, the sensor array can be rinsed with the organic solvent or water, as illustrated at 1010. Exemplary low boiling organic solvents include those described above. Alternatively, the organic solvent can be N-methyl pyrrolidone (NMP). The sensor array can be rinsed with low boiling organic solvents one or more times followed by a rinse with water. Optionally, the sensor array can be dried, such as with exposure to dry nitrogen, as illustrated at 1012.

[0054] The method of FIG. 10 can alternatively be applied to a wafer including multiple arrays. The wafer can be separated into individual arrays and caps applied to the individual arrays following drying the wafer.

[0055] Such treatment of sensor arrays has been shown to improve loading of polymeric beads that incorporating an analyte and secure the analyte in proximity to sensor pads of the sensor array. In particular, such treatment improves loading of polymeric beads that include polynucleotide analytes amplified thereon. For example, such treatment methods improve the performance of sequence sequencing devices. Such treatment of sensor arrays has been shown to improve sensor signal and signal-to-noise ratio (SNR), particularly in FET-based sensor arrays.

[0056] For example, FIG. 11 illustrates an exemplary sequencing system enhanced by the above described treatment methods. In a particular example illustrated in FIG. 11, polymeric particles can be used as a support for polynucleotides during sequencing techniques. For example, such hydrophilic particles can immobilize a polynucleotide for sequencing using fluorescent sequencing techniques. In another example, the hydrophilic particles can immobilize a plurality of copies of a polynucleotide for sequencing using ion-sensing techniques. Alternatively, the above described treatments can improve polymer matrix bonding to a surface of a sensor array. The polymer matrices can capture analytes, such as polynucleotides for sequencing.

[0057] In general, the polymeric particle can be treated to include a biomolecule, including nucleosides, nucleotides, nucleic acids (oligonucleotides and polynucleotides), polypeptides, saccharides, polysaccharides, lipids, or derivatives or analogs thereof. For example, a polymeric particle can bind or attach to a biomolecule. A terminal end or any internal portion of a biomolecule can bind or attach to a polymeric particle. A polymeric particle can bind or attach to a biomolecule using linking chemistries. A linking chemistry includes covalent or non-covalent bonds, including an ionic bond, hydrogen bond, affinity bond, dipole-dipole bond, van der Waals bond, and hydrophobic bond. A linking chemistry includes affinity between binding partners, for example between: an avidin moiety and a biotin moiety; an antigenic epitope and an antibody or immunologically reactive fragment thereof; an antibody and a hapten; a digoxigen moiety and an anti-digoxigen antibody; a fluorescein moiety and an anti-fluorescein antibody; an operator and a repressor; a nuclease and a nucleotide; a lectin and a polysaccharide; a steroid and a steroid-binding protein; an active compound and an active compound receptor; a hormone and a hormone receptor; an enzyme and a substrate; an immunoglobulin and protein A; or an oligonucleotide or polynucleotide and its corresponding complement.

[0058] As illustrated in FIG. 11, a plurality of polymeric particles 1104 can be placed in a solution along with a plu-

rality of polynucleotides 1102. The plurality of particles 1104 can be activated or otherwise prepared to bind with the polynucleotides 1102. For example, the particles 1104 can include an oligonucleotide complementary to a portion of a polynucleotide of the plurality of polynucleotides 1102. In another example, the polymeric particles 1104 can be modified with target polynucleotides 1104 using techniques such as biotin-streptavidin binding.

[0059] In a particular embodiment, the hydrophilic particles and polynucleotides are subjected to polymerase chain reaction (PCR) amplification or recombinase polymerase amplification (RPA). For example, dispersed phase droplets 1106 or 1108 are formed as part of an emulsion and can include a hydrophilic particle or a polynucleotide. In an example, the polynucleotides 1102 and the hydrophilic particles 1104 are provided in low concentrations and ratios relative to each other such that a single polynucleotide 1102 is likely to reside within the same dispersed phase droplets as a single hydrophilic particle 1104. Other droplets, such as a droplet 1108, can include a single hydrophilic particle and no polynucleotide. Each droplet 1106 or 1108 can include enzymes, nucleotides, salts or other components sufficient to facilitate duplication of the polynucleotide.

[0060] In a particular embodiment, an enzyme such as a polymerase is present, bound to, or is in close proximity to the hydrophilic particle or hydrogel particle of the dispersed phase droplet. In an example, a polymerase is present in the dispersed phase droplet to facilitate duplication of the polynucleotide. A variety of nucleic acid polymerase may be used in the methods described herein. In an exemplary embodiment, the polymerase can include an enzyme, fragment or subunit thereof, which can catalyze duplication of the polynucleotide. In another embodiment, the polymerase can be a naturally-occurring polymerase, recombinant polymerase, mutant polymerase, variant polymerase, fusion or otherwise engineered polymerase, chemically modified polymerase, synthetic molecules, or analog, derivative or fragment thereof.

[0061] Following PCR or RPA, particles are formed, such as particle 1110, which can include the hydrophilic particle 1112 and a plurality of copies 1114 of the polynucleotide. While the polynucleotides 1114 are illustrated as being on a surface of the particle 1110, the polynucleotides can extend within the particle 1110. Hydrogel and hydrophilic particles having a low concentration of polymer relative to water can include polynucleotide segments on the interior of and throughout the particle 1110 or polynucleotides can reside in pores and other openings. In particular, the particle 1110 can permit diffusion of enzymes, nucleotides, primers and reaction products used to monitor the reaction. A high number of polynucleotides per particle produces a better signal.

[0062] In embodiments, polymeric particles from an emulsion-breaking procedure can be collected and washed in preparation for sequencing. Collection can be conducted by contacting biotin moieties (e.g., linked to amplified polynucleotide templates which are attached to the polymeric particles) with avidin moieties, and separation away from polymeric particles lacking biotinylated templates. Collected polymeric particles that carry double-stranded template polynucleotides can be denatured to yield single-stranded template polynucleotides for sequencing. Denaturation steps can include treatment with base (e.g., NaOH), formamide, or pyrrolidone.

[0063] In an exemplary embodiment, the particle 1110 can be utilized in a sequencing device. For example, a sequencing device 1116 can include an array of wells 1118. The sequencing device 1116 can be treated with a wash solution including sulfonic acid, as described above. A particle 1110 can be placed within a well 1118.

[0064] In an example, a primer can be added to the wells 1118 or the particle 1110 can be pre-exposed to the primer prior to placement in the well 1118. In particular, the particle 1110 can include bound primer. The primer and polynucleotide form a nucleic acid duplex including the polynucleotide (e.g., a template nucleic acid) hybridized to the primer. The nucleic acid duplex is an at least partially double-stranded polynucleotide. Enzymes and nucleotides can be provided to the well 1118 to facilitate detectible reactions, such as nucleotide incorporation.

[0065] Sequencing can be performed by detecting nucleotide addition. Nucleotide addition can be detected using methods such as fluorescent emission methods or ion detection methods. For example, a set of fluorescently labeled nucleotides can be provided to the system 1116 and can migrate to the well 1118. Excitation energy can be also provided to the well 1118. When a nucleotide is captured by a polymerase and added to the end of an extending primer, a label of the nucleotide can fluoresce, indicating which type of nucleotide is added.

[0066] In an alternative example, solutions including a single type of nucleotide can be fed sequentially. In response to nucleotide addition, the pH within the local environment of the well 1118 can change. Such a change in pH can be detected by ion sensitive field effect transistors (ISFET). As such, a change in pH can be used to generate a signal indicating the order of nucleotides complementary to the polynucleotide of the particle 1110.

[0067] In particular, a sequencing system can include a well, or a plurality of wells, disposed over a sensor pad of an ionic sensor, such as a field effect transistor (FET). In embodiments, a system includes one or more polymeric particles loaded into a well which is disposed over a sensor pad of an ionic sensor (e.g., FET), or one or more polymeric particles loaded into a plurality of wells which are disposed over sensor pads of ionic sensors (e.g., FET). In embodiments, an FET can be a chemFET or an ISFET. A "chemFET" or chemical field-effect transistor, includes a type of field effect transistor that acts as a chemical sensor. The chemFET has the structural analog of a MOSFET transistor, where the charge on the gate electrode is applied by a chemical process. An "ISFET" or ion-sensitive field-effect transistor, can be used for measuring ion concentrations in solution; when the ion concentration (such as H⁺) changes, the current through the transistor changes accordingly.

[0068] In embodiments, the FET may be a FET array. As used herein, an "array" is a planar arrangement of elements such as sensors or wells. The array may be one or two dimensional. A one dimensional array can be an array having one column (or row) of elements in the first dimension and a plurality of columns (or rows) in the second dimension. The number of columns (or rows) in the first and second dimensions may or may not be the same. The FET or array can comprise 10², 10³, 10⁴, 10⁵, 10⁶, 10⁷ or more FETs.

[0069] In embodiments, one or more microfluidic structures can be fabricated above the FET sensor array to provide for containment or confinement of a biological or chemical reaction. For example, in one implementation, the microfluidic

structure(s) can be configured as one or more wells (or microwells, or reaction chambers, or reaction wells, as the terms are used interchangeably herein) disposed above one or more sensors of the array, such that the one or more sensors over which a given well is disposed detect and measure analyte presence, level, or concentration in the given well. In embodiments, there can be a 1:1 correspondence of FET sensors and reaction wells.

[0070] Returning to FIG. 11, in another example, a well 1118 of the array of wells can be operatively connected to measuring devices. For example, for fluorescent emission methods, a well 1118 can be operatively coupled to a light detection device. In the case of ionic detection, the lower surface of the well 1118 may be disposed over a sensor pad of an ionic sensor, such as a field effect transistor.

[0071] One exemplary system involving sequencing via detection of ionic byproducts of nucleotide incorporation is the Ion Torrent PGM™ or Proton™ sequencer (Life Technologies), which is an ion-based sequencing system that sequences nucleic acid templates by detecting hydrogen ions produced as a byproduct of nucleotide incorporation. Typically, hydrogen ions are released as byproducts of nucleotide incorporations occurring during template-dependent nucleic acid synthesis by a polymerase. The Ion Torrent PGM™ or Proton™ sequencer detects the nucleotide incorporations by detecting the hydrogen ion byproducts of the nucleotide incorporations. The Ion Torrent PGM™ or Proton™ sequencer can include a plurality of template polynucleotides to be sequenced, each template disposed within a respective sequencing reaction well in an array. The wells of the array can each be coupled to at least one ion sensor that can detect the release of H⁺ ions or changes in solution pH produced as a byproduct of nucleotide incorporation. The ion sensor comprises a field effect transistor (FET) coupled to an ion-sensitive detection layer that can sense the presence of H⁺ ions or changes in solution pH. The ion sensor can provide output signals indicative of nucleotide incorporation which can be represented as voltage changes whose magnitude correlates with the H⁺ ion concentration in a respective well or reaction chamber. Different nucleotide types can be flowed serially into the reaction chamber, and can be incorporated by the polymerase into an extending primer (or polymerization site) in an order determined by the sequence of the template. Each nucleotide incorporation can be accompanied by the release of H⁺ ions in the reaction well, along with a concomitant change in the localized pH. The release of H⁺ ions can be registered by the FET of the sensor, which produces signals indicating the occurrence of the nucleotide incorporation. Nucleotides that are not incorporated during a particular nucleotide flow may not produce signals. The amplitude of the signals from the FET can also be correlated with the number of nucleotides of a particular type incorporated into the extending nucleic acid molecule thereby permitting homopolymer regions to be resolved. Thus, during a run of the sequencer multiple nucleotide flows into the reaction chamber along with incorporation monitoring across a multiplicity of wells or reaction chambers can permit the instrument to resolve the sequence of many nucleic acid templates simultaneously.

[0072] In a first aspect, a sensor array includes a plurality of sensors. A sensor of the plurality of sensors has a sensor pad exposed at a surface of the sensor array. A method of treating the sensor array includes exposing at least the sensor pad to a

wash solution including acid and an organic solvent and rinsing the wash solution from the sensor pad.

[0073] In a second aspect, a sensor array includes a plurality of sensors. A sensor of the plurality of the sensors includes a sensor pad. A well structure defines a well array corresponding with the sensor array. A well of the well array exposes the sensor pad. A cap is attached over the sensor array and the well structure and includes a fluid port. A space is defined between the cap and the well structure. A method of treating the sensor array includes applying a wash solution through the fluid port into the space and waiting for a first period between 30 seconds and 30 minutes. The wash solution includes acid and an organic solvent. The method further includes applying a basic solution through the fluid port into the space and waiting for a second period between 20 seconds and 15 minutes and applying a rinse solution through the fluid port. In an example of the second aspect, the method further includes repeating applying the wash solution and applying the basic solution.

[0074] In a third aspect, a sensor array includes a plurality of sensors. A sensor of the plurality of sensors includes a sensor pad. A well structure defines a well array corresponding with the sensor array. A well of the well array exposes the sensor pad. A method of treating the sensor array includes applying a wash solution to at least the sensor pad and waiting for a first period between 30 seconds and 30 minutes. The wash solution includes acid and an organic solvent. The method further includes rinsing at least the sensor pad with a low boiling organic solvent and drying the sensor array. In an example of the third aspect, the method further includes rinsing with water following rinsing with the low boiling organic solvent and prior to drying. In another example of the third aspect and the above examples, the method further includes attaching a cap over the sensor array and the well array, the cap including a fluid port, a space defined between the cap and the well array in fluid communication with the fluid port.

[0075] In an example of the first, second, and third aspects and the above examples, the acid includes a sulfonic acid. The sulfonic acid can include an alkyl sulfonic acid, alkyl aryl sulfonic acid, or a combination thereof. In an example, the alkyl aryl sulfonic acid includes an alkyl group having between 1 and 20 carbons. For example, the alkyl group has between 9 and 18 carbons, such as between 10 and 14 carbons. In another example, the alkyl group has between 1 and 6 carbons.

[0076] In another example of the first, second, and third aspects and the above examples, the sulfonic acid includes dodecyl benzene sulfonic acid. In a further example of the first, second, and third aspects and the above examples, the sulfonic acid includes methanesulfonic acid, ethanesulfonic acid, propane sulfonic acid, butane sulfonic acid, or combinations thereof. In an additional example of the first, second, and third aspects and the above examples, the sulfonic acid includes para toluene sulfonic acid.

[0077] In a further example of the first, second, and third aspects and the above examples, the wash solution includes between 10 mM and 500 mM of the acid. For example, the wash solution includes between 50 mM and 250 mM of the acid.

[0078] In an additional example of the first, second, and third aspects and the above examples, the wash solution includes between 0.5 wt % and 25 wt % of the acid. For

example, the wash solution includes between 1 wt % and 10 wt % of the acid, such as between 2.5 wt % and 5 wt % of the acid.

[0079] In another example of the first, second, and third aspects and the above examples, the organic solvent is non-polar.

[0080] In a further example of the first, second, and third aspects and the above examples, the organic solvent has a normal boiling point in a range of 36° C. to 345° C. For example, the normal boiling point is in a range of 65° C. to 275° C. In an example, the normal boiling point is in a range of 65° C. to 150° C. In an alternative example, the normal boiling point is in a range of 150° C. to 220° C.

[0081] In an additional example of the first, second, and third aspects and the above examples, the organic solvent is an alkane having between 6 and 24 carbons. For example, the alkane has between 6 and 14 carbons, such as between 6 and 9 carbons or alternatively, between 10 and 14 carbons.

[0082] In a further example of the first, second, and third aspects and the above examples, the organic solvent is an aprotic polar solvent. For example, the polar aprotic solvent includes tetrahydrofuran, ethylacetate, acetone, dimethylformamide, acetonitrile, dimethyl sulfoxide, N-methyl pyrrolidone (NMP), or combinations thereof.

[0083] In another example of the first, second, and third aspects and the above examples, the method further includes heating the sensor pad and the wash solution while exposing the sensor pad to the wash solution. For example, heating includes heating at a temperature in a range of 35° C. to 70° C. For example, the temperature is in a range of 40° C. to 55° C.

[0084] In a further example of the first, second, and third aspects and the above examples, exposing includes exposing for a period in a range of 30 seconds to 30 minutes. For example, the period is in a range of 30 seconds to 10 minutes, such as in a range of 30 seconds to 5 minutes or in a range of 1 minute to 3 minutes.

[0085] In an additional example of the first, second, and third aspects and the above examples, the method further includes exposing at least the sensor pad to a basic solution. For example, the basic solution includes between 0.005M and 1.5M sodium hydroxide, such as between 0.01M and 1.0M sodium hydroxide or between 0.01M and 0.5M sodium hydroxide. In an additional example, exposing at least the sensor pad to the basic solution occurs following exposing the sensor pad to the wash solution. The method can further include repeating exposing at least the sensor pad to the wash solution and exposing at least the sensor pad to the basic solution.

[0086] In another example of the first, second, and third aspects and the above examples, rinsing includes rinsing with a low boiling organic solvent having a normal boiling point in a range of 25° C. to 100° C. For example, the low boiling organic solvent has a normal boiling point in a range of 50° C. to 100° C. In a particular example, the low boiling organic solvent includes alcohol. For example, the alcohol includes ethanol or isopropanol.

[0087] In a further example of the first, second, and third aspects and the above examples, rinsing includes rinsing with water.

[0088] In a fourth aspect, a system includes a sensor device treated by the method of any one of the above aspects and examples.

[0089] In a fifth aspect, a solution includes 2.5 wt % to 5 wt % sulfonic acid and a non-polar linear alkane having between 6 and 18 carbons.

[0090] In a sixth aspect, a kit includes a nucleotide solution including at least one nucleotide type, polymeric particles, and a wash solution including 0.5 wt % to 20 wt % sulfonic acid and an organic solvent having a normal boiling point in a range of 65° C. to 275° C.

[0091] Note that not all of the activities described above in the general description or the examples are required, that a portion of a specific activity may not be required, and that one or more further activities may be performed in addition to those described. Still further, the order in which activities are listed are not necessarily the order in which they are performed.

[0092] Particular salts of above described acids or bases can have activity, and may be useful in the above described methods. Salts include alkali or alkali earth metal salts, or tetraalkylammonium salts of the above acids or bases.

[0093] In the foregoing specification, the concepts have been described with reference to specific embodiments. However, one of ordinary skill in the art appreciates that various modifications and changes can be made without departing from the scope of the invention as set forth in the claims below. Accordingly, the specification and figures are to be regarded in an illustrative rather than a restrictive sense, and all such modifications are intended to be included within the scope of invention.

[0094] As used herein, the terms “comprises,” “comprising,” “includes,” “including,” “has,” “having” or any other variation thereof, are intended to cover a non-exclusive inclusion. For example, a process, method, article, or apparatus that comprises a list of features is not necessarily limited only to those features but may include other features not expressly listed or inherent to such process, method, article, or apparatus. Further, unless expressly stated to the contrary, “or” refers to an inclusive-or and not to an exclusive-or. For example, a condition A or B is satisfied by any one of the following: A is true (or present) and B is false (or not present), A is false (or not present) and B is true (or present), and both A and B are true (or present).

[0095] Also, the use of “a” or “an” are employed to describe elements and components described herein. This is done merely for convenience and to give a general sense of the scope of the invention. This description should be read to include one or at least one and the singular also includes the plural unless it is obvious that it is meant otherwise.

[0096] Benefits, other advantages, and solutions to problems have been described above with regard to specific embodiments. However, the benefits, advantages, solutions to problems, and any feature(s) that may cause any benefit, advantage, or solution to occur or become more pronounced are not to be construed as a critical, required, or essential feature of any or all the claims.

[0097] After reading the specification, skilled artisans will appreciate that certain features are, for clarity, described herein in the context of separate embodiments, may also be provided in combination in a single embodiment. Conversely, various features that are, for brevity, described in the context of a single embodiment, may also be provided separately or in any subcombination. Further, references to values stated in ranges include each and every value within that range.

1.-53. (canceled)

54. A method of treating a sensor array, the sensor array including a plurality of sensors, a sensor of the plurality of sensors having a sensor pad exposed at a surface of the sensor array, the method comprising:

exposing at least the sensor pad to a wash solution including acid and an organic solvent; and

rinsing the wash solution from the sensor pad.

55. The method of claim **54**, wherein the acid includes sulfonic acid.

56. The method of claim **55**, wherein the sulfonic acid includes alkyl sulfonic acid, alkyl aryl sulfonic acid, or a combination thereof.

57. The method of claim **56**, wherein the alkyl aryl sulfonic acid includes an alkyl group having between 1 and 20 carbons.

58. The method of claim **55**, wherein the sulfonic acid includes dodecyl benzene sulfonic acid.

59. The method of claim **54**, wherein the wash solution includes between 10 mM and 500 mM of the acid.

60. The method of claim **54**, wherein the wash solution includes between 0.5 wt % and 25 wt % of the acid.

61. The method of claim **54**, wherein the organic solvent is non-polar.

62. The method of claim **54**, wherein the organic solvent has a normal boiling point in a range of 36° C. to 345° C.

63. The method of claim **54**, wherein the organic solvent is an alkane having between 6 and 24 carbons.

64. The method of claim **54**, wherein the organic solvent is a polar aprotic solvent.

65. The method of claim **64**, wherein the polar aprotic solvent includes tetrahydrofuran, ethylacetate, acetone, dimethylformamide, acetonitrile, dimethyl sulfoxide, N-methyl pyrrolidone, or combinations thereof.

66. The method of claim **54**, further comprising heating the sensor pad and the wash solution while exposing the sensor pad to the wash solution at a temperature in a range of 35° C. to 70° C.

67. The method of claim **54**, wherein exposing includes exposing for a period in a range of 30 seconds to 30 minutes.

68. The method of claim **54**, further comprising exposing at least the sensor pad to a basic solution following exposing the sensor pad to the wash solution.

69. The method of claim **68**, wherein the basic solution includes between 0.005M and 1.5M sodium hydroxide.

70. The method of claim **54**, wherein rinsing includes rinsing with a rinse organic solvent miscible with water and the organic solvent.

71. The method of claim **70**, wherein the low boiling organic solvent includes alcohol.

72. A method of treating a sensor array, the sensor array including a plurality of sensors, a sensor of the plurality of sensors including a sensor pad, a well structure defining a well array corresponding with the sensor array, a well of the well array exposing the sensor pad, a cap attached over the sensor array and the well structure and including a fluid port, a space defined between the cap and the well structure, the method comprising:

applying a wash solution through the fluid port into the space and waiting for a first period between 30 seconds and 30 minutes, the wash solution including acid and an organic solvent;

applying a basic solution through the fluid port into the space and waiting for a second period between 20 seconds and 15 minutes; and

applying a rinse solution through the fluid port.

73. The method of claim 72, further comprising repeating applying the wash solution, applying the basic solution, and applying the rinse solution.

* * * * *