



EUROPEAN PATENT APPLICATION

 Application number: 85850354.3



 Int. Cl.⁴: E05C 1/14

 Date of filing: 05.11.85



 Priority: 07.11.84 SE 8405570

 Applicant: BRÄCKE MEKAN AB
 Box 122
 S-840 60 Bräcke(SE)



 Date of publication of application:
 21.05.86 Bulletin 86/21



 Inventor: LÖÖK, Torsten
 Tolvmansvägen 7
 S-834 00 Brunsflo(SE)

 Designated Contracting States:
 AT BE CH DE FR GB IT LI LU NL

 Representative: Lenz, Franz et al
 AWAPATENT AB Box 5117
 S-200 71 Malmö(SE)

Device for locking the sideboards of a vehicle platform and sideboard profile therefor.

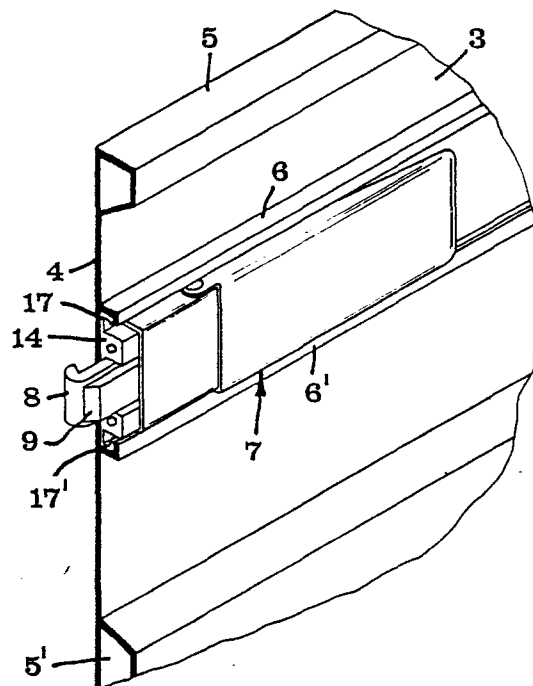
 A device (7) for locking the sideboards of a vehicle platform comprises at least one locking bolt (8, 9) which is movable by means of an operating mechanism having a handle portion (10) connected to the locking bolt by at least one articulated link adapted to convert a pivotal movement of the handle portion into a movement of displacement of the locking bolt. The movable components of the locking device are maintained relative to a frame or base member (14) by at least two male-type projections which engage with female-type guide means and are movable back and forth therein. The guide means are in the form of internal grooves in rails (17, 17') which project from opposite sides of the locking device and are insertible and stationarily mountable in channel-shaped brackets (6, 6') associated with the sideboard (3) of the vehicle platform.



EP 0 181 848 A2

DEVICE FOR LOCKING THE SIDEBOARDS OF A VEHICLE PLATFORM AND SIDEBOARD PROFILE THEREFOR

The present invention relates to a device for locking the sideboards of a vehicle platform, comprising at least one locking bolt which is movable by means of an operating mechanism having a handle portion connected to said bolt by at least one articulated link adapted to convert a pivotal movement of the handle portion into a movement of displacement of the locking bolt, the movable components of the locking device being maintained relative to a frame or base member by at least two male-type projections which engage with female-type guide means and are movable back and forth therein.

State of the art

A device for locking the sideboards of a vehicle platform of the above-mentioned type is previously known from SE published application 8306445-1. In this locking device, said two projections consist of two sheet-metal flaps or feet which are part of an auxiliary locking bolt and engage underneath L-shaped guide rails mounted on the inner side of the side walls of a trough accommodating the locking device and positively forming the frame of the locking device. The trough is mounted in a recess in the sideboard of a vehicle platform, the sideboard being preferably made up of a number of aluminium profiles. In practice, the trough is mounted by riveting. Analogously, the two L-shaped guide rails are also secured to the side walls of the trough by riveting. The use of rivets (like equivalent fixing methods, such as welding) however requires a number of time-consuming operations substantially increasing the costs for the finally mounted locking device.

Brief description of the inventive concept

The object of the present invention is to overcome the problems encountered in the mounting of locking devices for platform sideboards and to provide a locking device which not only is inexpensive to manufacture but also allows rapid and uncomplicated mounting. According to the invention, this and other objects are achieved more specifically in that the guide means are in the form of internal grooves in rails which project from opposite sides of the locking device and are insertible and stationarily mountable in channel-shaped brackets associated with the contemplated sideboard.

Brief description of accompanying drawings

In the drawings, Figs. 1 and 2 are partial perspective views showing part of the sideboard of a vehicle platform, with a locking device according to the invention mounted thereon, Fig. 3 is a part sectional top plan view of the locking device according to Fig. 1, Fig. 4 is a side view of the same locking device, Fig. 5 is an end view according to V-V in Fig. 4, and Figs. 6-8 are similar views showing an alternative embodiment of the invention.

Detailed description of preferred embodiments of the invention

In Fig. 1, 1 generally designates the pivotable sideboard of a vehicle platform, composed of a number of planar aluminium profiles which are held together by a common post 2 in the form of a U-profile. In the drawing, only the uppermost of the sideboard forming aluminium profiles is visible. The profile 3 is a special profile which, in addition to a planar plate 4 and two edge portions 5, 5' in

the form of box sections, comprises two L-shaped longitudinal portions 6, 6' forming brackets for the locking device according to the invention generally designated 7. It should be noted that the free flanges of the L-shaped portions 6, 6' are directed towards each other.

Reference is now also made to Figs. 3-5 illustrating the construction of the locking device 7 in greater detail. It is previously known per se in all essential aspects from said SE published application 8306445-1. Thus, the locking device 7 comprises a main bolt 8, an auxiliary bolt 9 and a handle portion 10 connected to the main bolt 8 by two articulated, pivotable links 11. Further, the handle portion 10 is hingedly connected at its forward end at 12 to a profile 13 of U-shaped cross-section which is part of or otherwise rigidly connected to the auxiliary bolt 9. The U-profile 13 is maintained, although axially displaceable in relation to a base member or frame 14 by means of footlike projections 15, 15' which engage in female-type guide means 16, 16'.

As described so far, the locking device 7 proper is substantially already known from SE published application 8306445-1.

According to the principle of the invention, the guide means 16, 16' consist of internal grooves in rails 17, 17' which project from opposite sides of the locking device and which in turn are insertible and stationarily mountable in the above-mentioned brackets 6, 6'. Thus, the base member 14 can be manufactured in a very simple way by compression moulding or injection moulding of plastic, the resulting plastic member being provided with one or two screw or rivet holes 18, 18'.

The locking device according to the invention is extremely easy to mount. The two rails 17, 17' are inserted in the two L-shaped brackets 6, 6'. After mounting of the U-profile 2, the locking device is anchored relative to the brackets 6, 6' by applying screws or rivets 19, 19' in said holes 18, 18'. Instead of such screws or rivets, it is also possible to apply a simple fixing means, such as a screw, through the profile wall 4 and into the base member 14.

According to a special feature of the invention, said brackets 6, 6' may advantageously also be used for receiving tapes or plates with advertising text or the like in the space beside the locking device 7.

In Figs. 6-8, it is illustrated how the locking device 7 according to the invention can also be readily mounted in a trough mounted in the sideboard of a vehicle platform that has no special profile 3 as illustrated in Figs. 1-2. In this case, the locking device is inserted in a relatively short profile member 20, e.g. of aluminium, at one end of which there is mounted a transverse end piece 21 which, together with two side walls 22, 22' and a bottom 23, defines a relatively shallow, wide space, yielding a simple and inexpensive trough. The walls 22, 22' are formed with recessed portions 24, 24' constituting brackets for receiving the mounting rails 17, 17' of the locking device. In addition to the locking device described above and illustrated in the drawings, the invention also relates to the special sideboard profile shown in Figs. 1-2.

Possible modifications of the invention

Naturally, the invention is not restricted only to the embodiments described above and illustrated in the drawings. Thus, it is conceivable to apply the invention also in connection with locking devices for platform sideboards other than precisely the locking device disclosed in SE published application 8306445-1.

Claims

1. A device for locking the sideboards of a vehicle platform, comprising at least one locking bolt (8, 9) which is movable by means of an operating mechanism having a handle portion (10) connected to said bolt by at least one articulated link (11) adapted to convert a pivotal movement of the handle portion into a movement of displacement of the locking bolt, the movable components (8, 9, 10, 11) of the locking device being maintained relative to a frame or base member (14) by at least two male-type projections (15, 15') which engage with female-type guide means and are movable back and forth therein, **characterised** in that said guide means are in the form of internal grooves (16, 16') in rails (17, 17') which project from opposite sides of the locking device and are insertible and stationarily mountable in channel-shaped brackets (6, 6'; 24, 24') associated with the contemplated sideboard (1).
2. Device as claimed in claim 1, **characterised** in that the brackets (6, 6') constitute portions of a profile (3) which alone or together with other profiles makes up the contemplated sideboard (1).
3. Device as claimed in claim 2, **characterised** in that the bracket-forming portions (6, 6') are of L-shaped cross-section.
4. Device as claimed in claim 1, **characterised** in that the brackets (24, 24') constitute portions of a profile (20) which together with an end piece (21) forms a trough which in turn is mountable in the sideboard.
5. Sideboard profile for receiving a locking device as claimed in claim 1, **characterised** in that it has two elongate portions (6, 6') of L-shaped cross-section which form brackets for receiving the rails (17, 17') projecting from opposite sides of the locking device (7).
6. Profile as claimed in claim 5, **characterised** in that said bracket-forming portions (6, 6') of the profile are disposed between two hollow, reinforcing box sections (5, 5') between which there extends a planar wall (4) which is common not only to the box sections but also to said bracket-forming portions (6, 6').
7. Profile as claimed in claim 5 or 6, **characterised** in that the bracket-forming portions (6, 6') are essentially longer than the locking device (7) per se, the space beside the locking device being usable for receiving carriers of advertising text or the like.

5
10
15
20
25
30
35
40
45
50
55
60
65

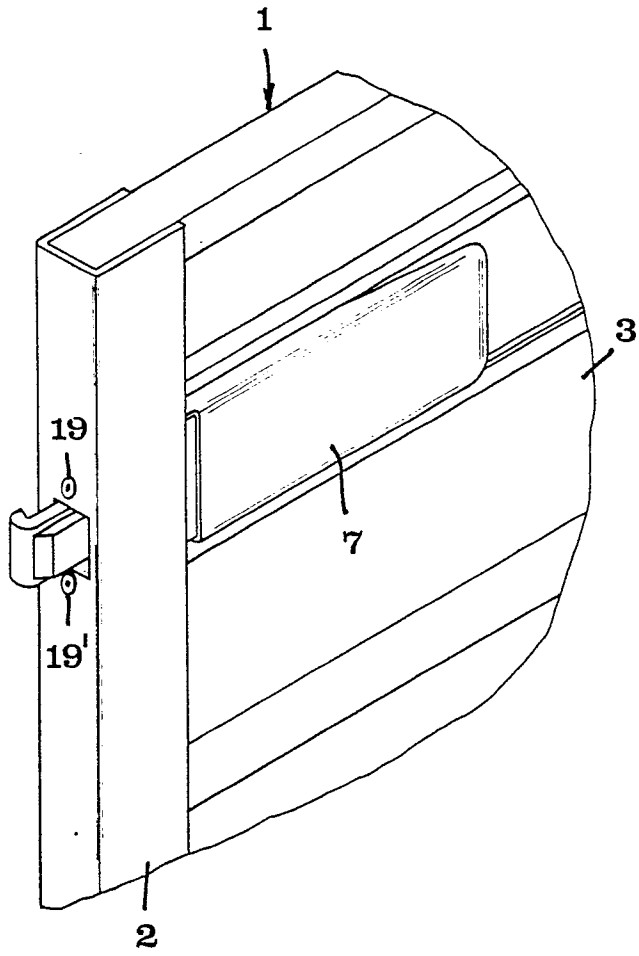

FIG 1

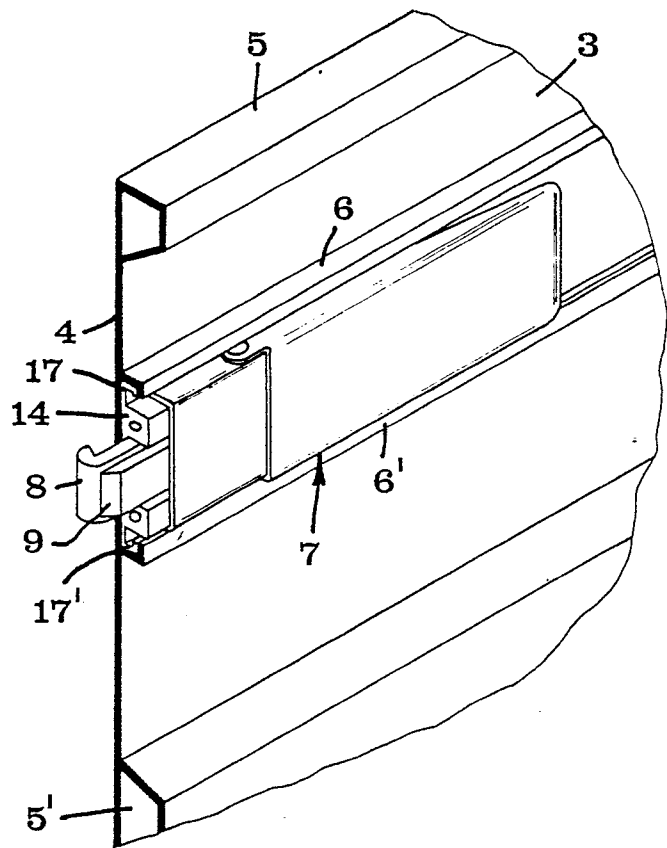

FIG 2

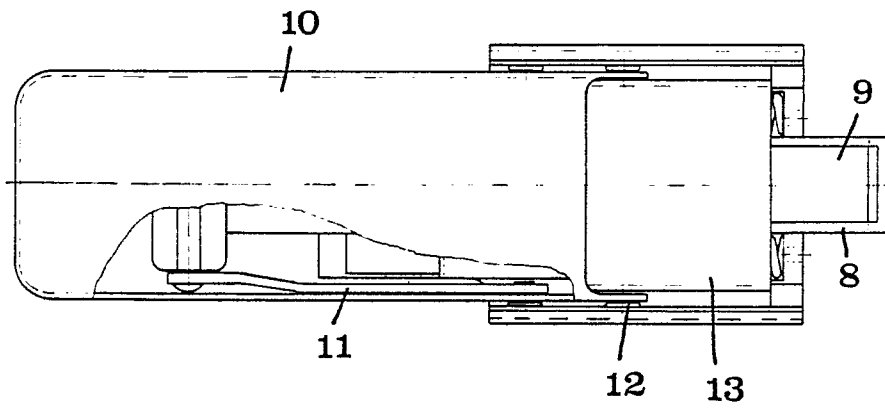

Fig 3

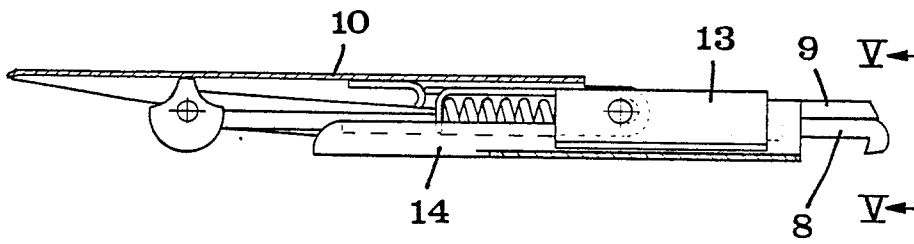

Fig 4

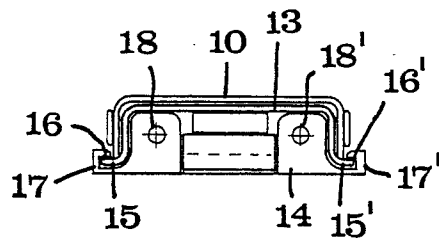

Fig 5

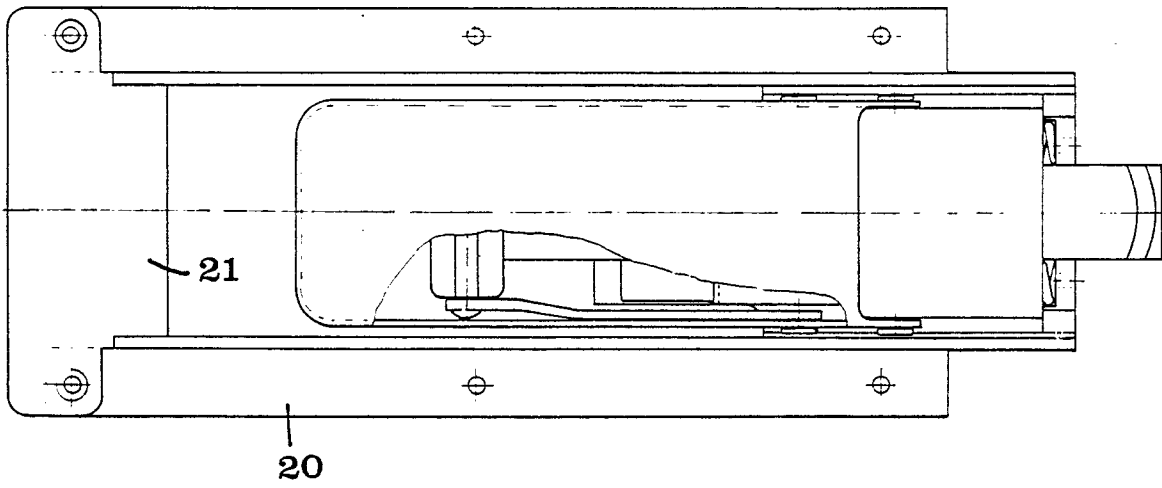

Fig 6

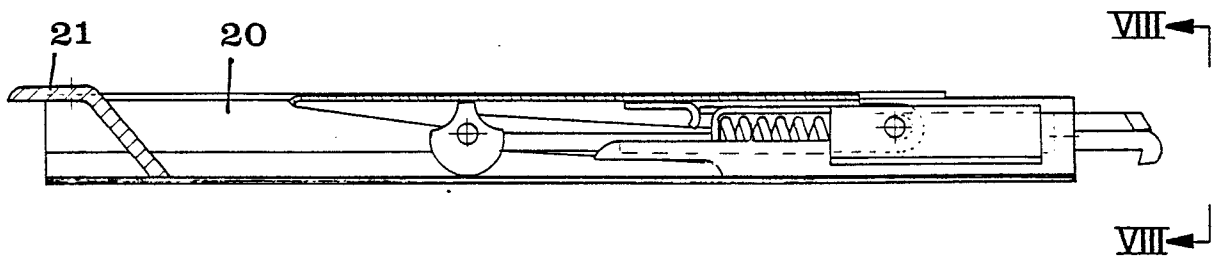

Fig 7

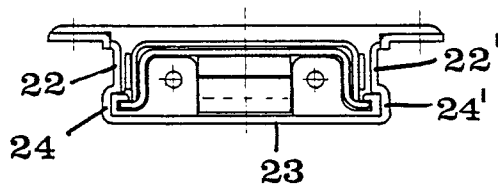

Fig 8