

(No Model.)

J. P. SMITH.
ICE ELEVATOR PLANE.

No. 523,714.

Patented July 31, 1894.

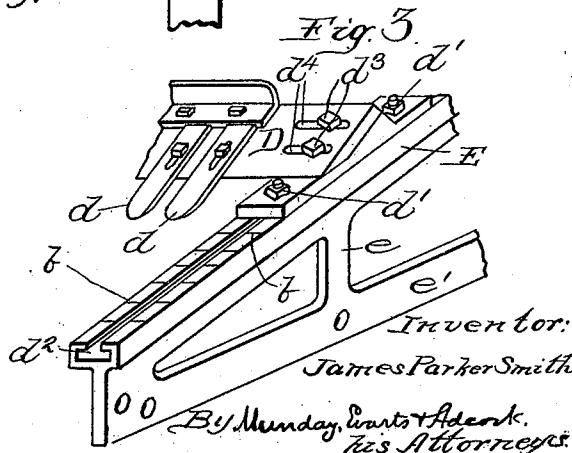
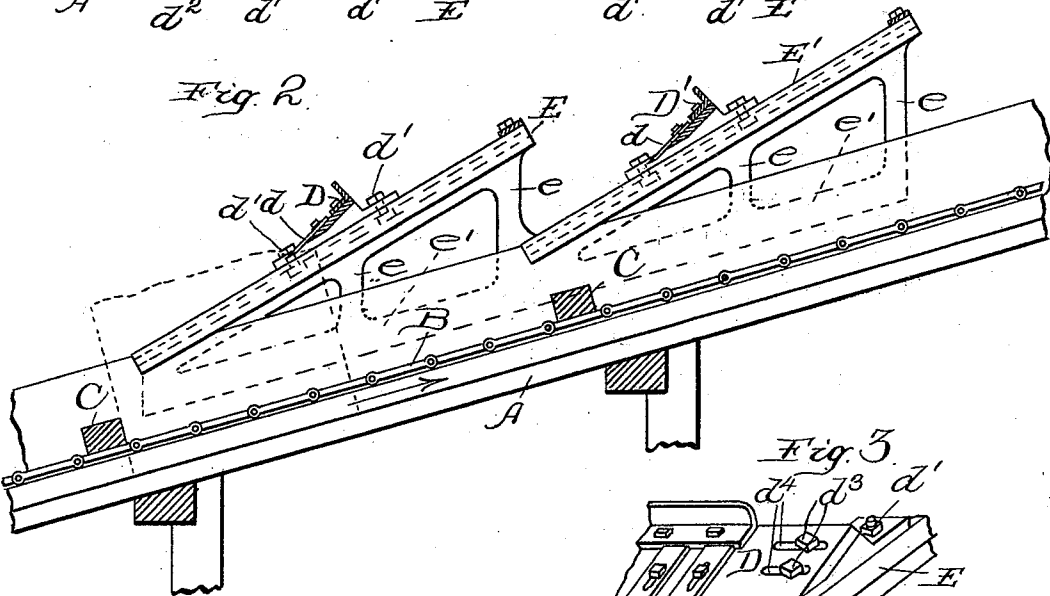
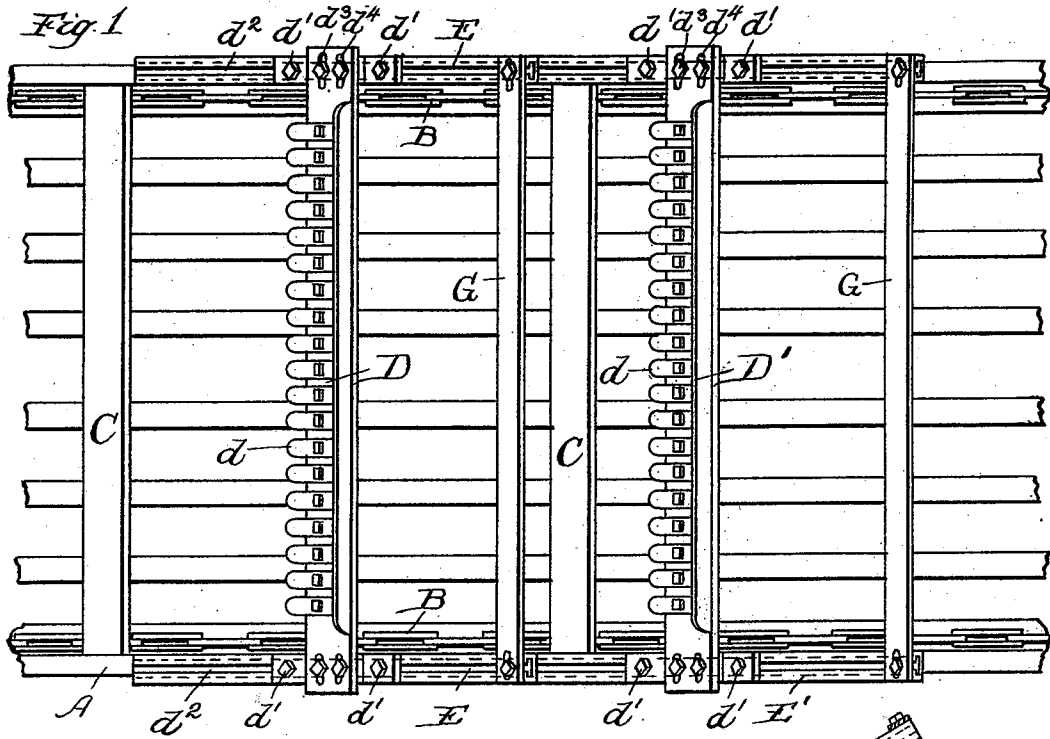

Witnesses:
Sew. C. Curtis
Emma Hawk

Inventor:
James Parker Smith

By Munday, Smart & Adcock,
his Attorneys.

UNITED STATES PATENT OFFICE.

JAMES PARKER SMITH, OF CHICAGO, ILLINOIS, ASSIGNOR OF ONE-THIRD TO
ALEXANDER D. JOSLIN, OF SAME PLACE.

ICE-ELEVATOR PLANE.

SPECIFICATION forming part of Letters Patent No. 523,714, dated July 31, 1894.

Application filed December 18, 1893. Serial No. 493,966. (No model.)

To all whom it may concern:

Be known that I, JAMES PARKER SMITH, a citizen of the United States, residing in Chicago, in the county of Cook and State of Illinois, have invented a new and useful Improvement in Ice-Elevator Planes, of which the following is a specification.

This invention relates to an improvement in the construction of planing devices for ice elevators.

When the ice is cut from the pond preparatory to storing it, it is found desirable to plane or cut off the upper surface of the same, which is apt to contain impurities and dirt or imperfect ice formed by the melting of the snow which falls on the upper surface of the pond. For this purpose it has been sometimes customary to provide the inclined way or elevator which raises the ice from the pond to the store house, with a planing or cutting device, arranged to plane off the upper surface of the ice to the desired depth, and which planing device is usually made adjustable up and down to accommodate different thicknesses of ice, so that the same may be adjusted to suit the ice which is being stored.

The present invention relates to a novel mounting of such planer device whereby the same may be adjusted to and from the bed on the conveyer to suit different conditions of the ice, and at the same time be exceedingly strong and simple in construction.

The invention further relates to providing the ice elevator with two of the planing devices so constructed in order that the amount of cutting may be divided between the two planers whereby the ice is more easily operated on and prevented from tilting in the act of cutting.

In the accompanying drawings which form a part of this specification, Figure 1 represents a plan view of a portion of an ice elevator provided with my invention. Fig. 2 is a sectional elevation of the same, and Fig. 3 is a detail view of a portion of the planer arrangement shown in perspective.

In said drawings A represents the inclined frame work of the ice elevator.

B B are the hoisting chains and C C are cross pieces which engage the ice contained in the inclined chute and cause the same to

slide upward along the slatted floor of the chute.

D is an ice planer, which in the instance illustrated consists of the usual series of grooving chisels *d* secured to a packing piece as shown. Particular description of this device is unnecessary as it is well known to those skilled in the art.

E is an inclined way suitably grooved to receive the planer head, and one of these inclined ways is fitted to each side of the ice chute, the same being supported from the standards *e e* and the base *e'* the latter being secured by suitable bolts to the side frame pieces of the ice chute. It will be noticed that the inclination of the way E is at a greater angle than the inclination of the ice chute, so that when the knife head of the planer is adjusted at different positions on the inclined ways E, it is thereby raised or lowered from the ice chute. Bolts *d'* serve to secure the planer head in position upon the inclined ways E, the heads of said bolts setting into the grooves *d²* in said ways E.

The wedge shaped or inclined supports E offer a very strong and secure method of attaching the planer heads adjustably, as the thrust of the ice in its elevation against the planer head is somewhat in line with the supports of said head.

The base piece *e'* in the construction illustrated in the drawings is extended and the inclined ways E duplicated in the incline E', so that a second knife D' may be secured adjustably to the inclined rear supports E', the same as the knife D is secured to the supports E. The purpose of thus duplicating the knife heads is in order that the ice may be planed in two cuts instead of one. Whether the amount to be cut from the surface of the ice is great or small, I find that there is an advantage in taking two cuts instead of one as the ice is thereby less apt to tip or break in the operation. When the ice is engaged by both the cutter heads for instance, it cannot tip. And the depth of the cut of either of the cutter heads in such case is of course less and the tendency to tip, break or become displaced, or for the elevator to clog, or the knives to break is much lessened.

The knife heads are connected as shown to

the inclined ways or supports by means of bolts d^3 passing through slots d^4 into a shoe which latter in turn is connected by the bolts d' with the ways or inclined supports. Cross bars G at the upper ends of the inclined ways or supports are shown as extending from one side to the other and are connected to said supports by slots and bolts. These bars G are not essential however to the structure, being simply an extra precaution, as the knife heads themselves afford sufficient bracing and strength ordinarily. It will be noticed that the connection of the knife heads to the supports or incline ways, being slotted, enables the apparatus to be applied easily to elevators already erected and of varying widths which is a great convenience in the manufacture and sale of the device.

In order to afford a means of setting the

knife head at any desired height with respect to the ice, I mark the face of each of the inclined ways or supports with a scale, as shown in Fig. 3 at b . This enables the knife head to be set true and square in adjusting it to different heights and enables the proper height to be easily determined.

I claim—

The combination with the ice elevator framework of the planer supports E set at an acute vertical angle to said frame-work, the planer head and means for adjustably securing said head to the supports, substantially as specified.

JAMES PARKER SMITH.

Witnesses:

H. M. MUNDAY,
LEW. E. CURTIS.