



US 20050066461A1

(19) **United States**

(12) **Patent Application Publication**

**Chang**

(10) **Pub. No.: US 2005/0066461 A1**

(43) **Pub. Date: Mar. 31, 2005**

(54) **EFFICIENT TRAINING TOOTH BRUSH FOR CHILDREN**

**Publication Classification**

(51) **Int. Cl.<sup>7</sup> ..... A46B 9/04**

(52) **U.S. Cl. .... 15/105**

(76) **Inventor: Ping Tzu Chang, Palos Verdes Estates, CA (US)**

(57) **ABSTRACT**

Correspondence Address:  
**Law Offices of Ira J. Nasserian & Associates  
Suite 200  
2250 E. Imperial HWY.  
El Segundo, CA 90245-3508 (US)**

A toothbrush assembly having a pressure-sensing device for activating an audible system disposed within the toothbrush. One embodiment discloses a toothbrush adapted to play music when pressure is applied longitudinally on toothbrush bristles. In another embodiment, toothbrush music playing function is activated when pressure is within a predetermined range. In another embodiment, a toothbrush comprises of a handle depicting different animals with a switch on its belly adapted to dispense toothpaste when pressure is applied to the belly.

(21) **Appl. No.: 10/675,150**

(22) **Filed: Sep. 29, 2003**

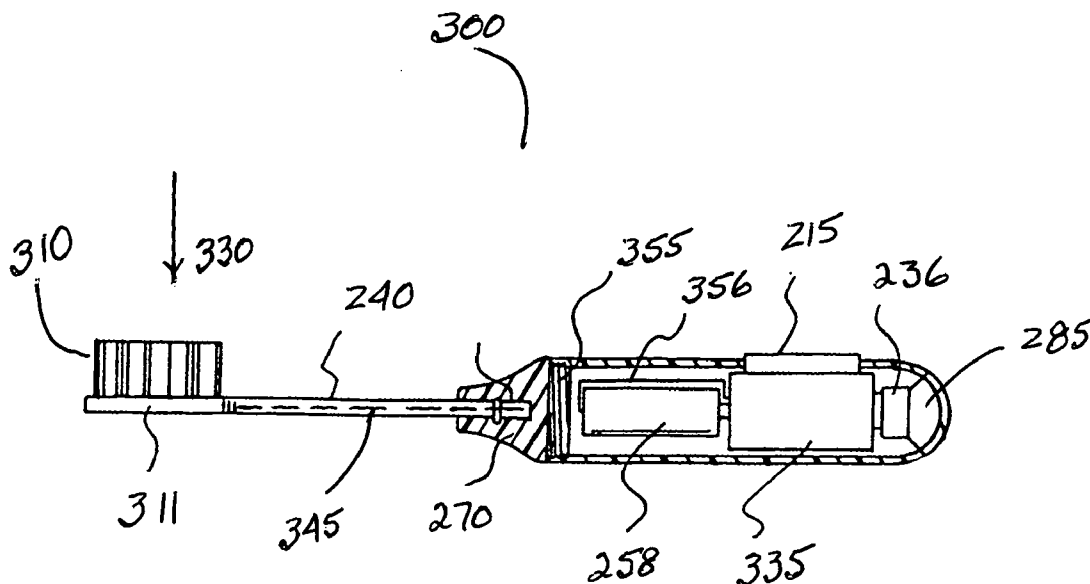

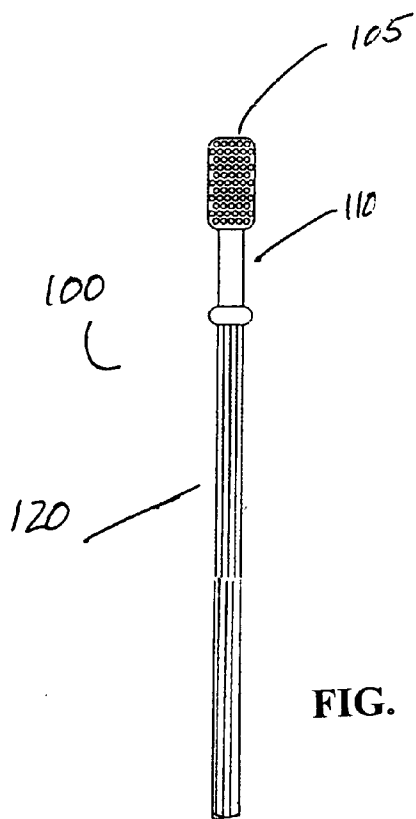

FIG. 1A

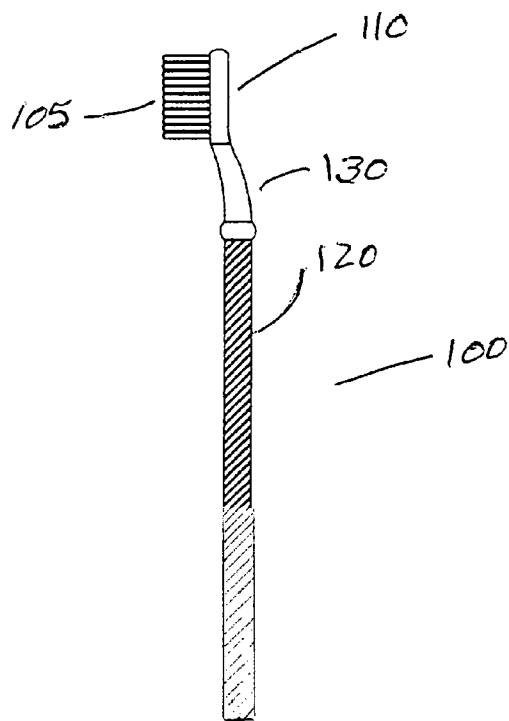

FIG. 1B

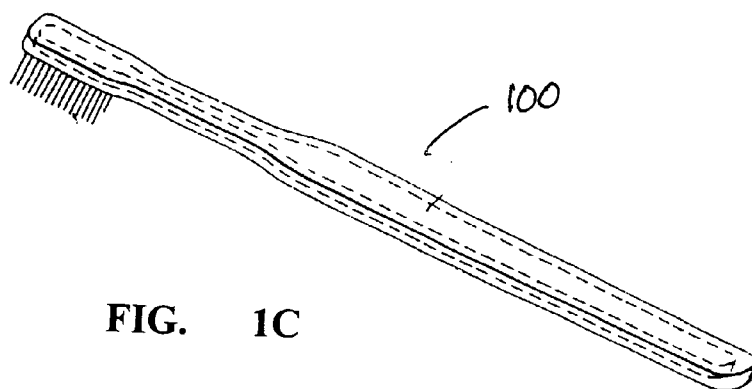

FIG. 1C

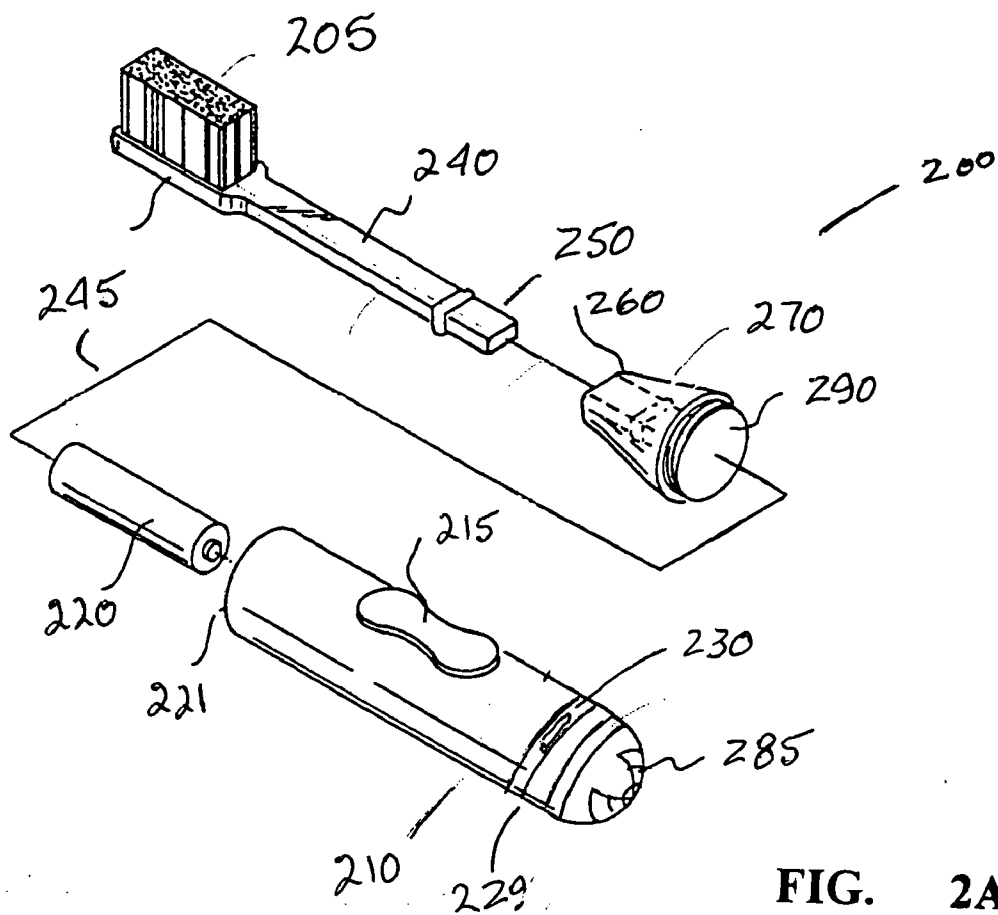

FIG. 2A

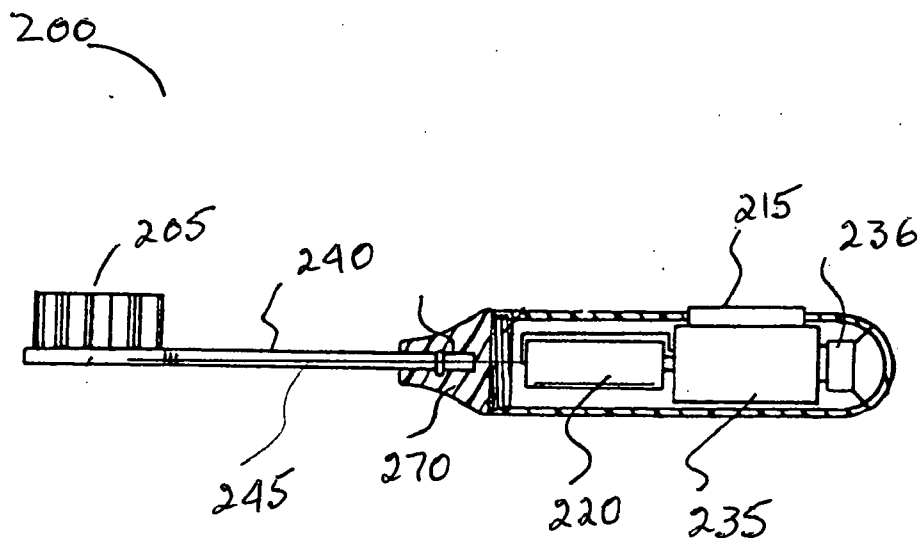
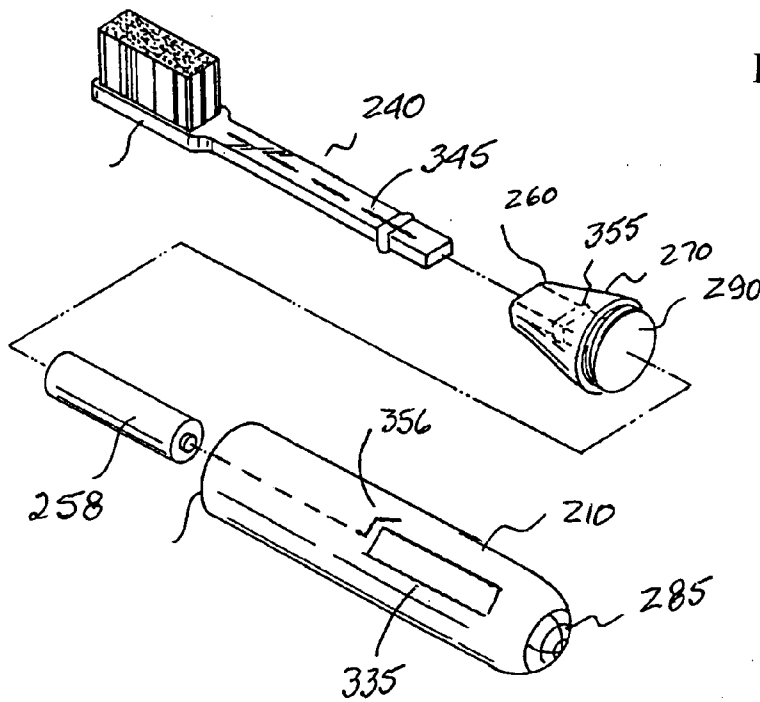
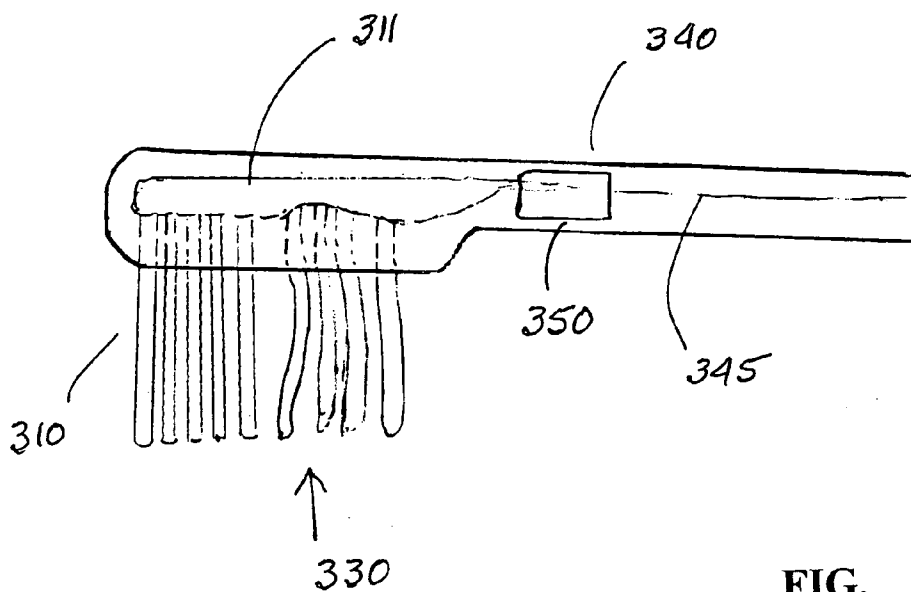

FIG. 2B



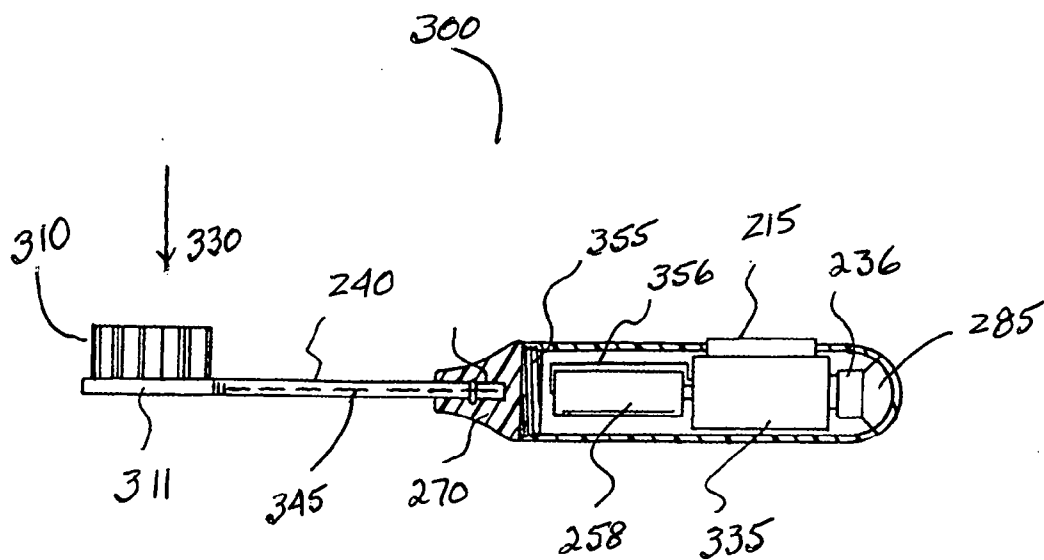

FIG. 3C

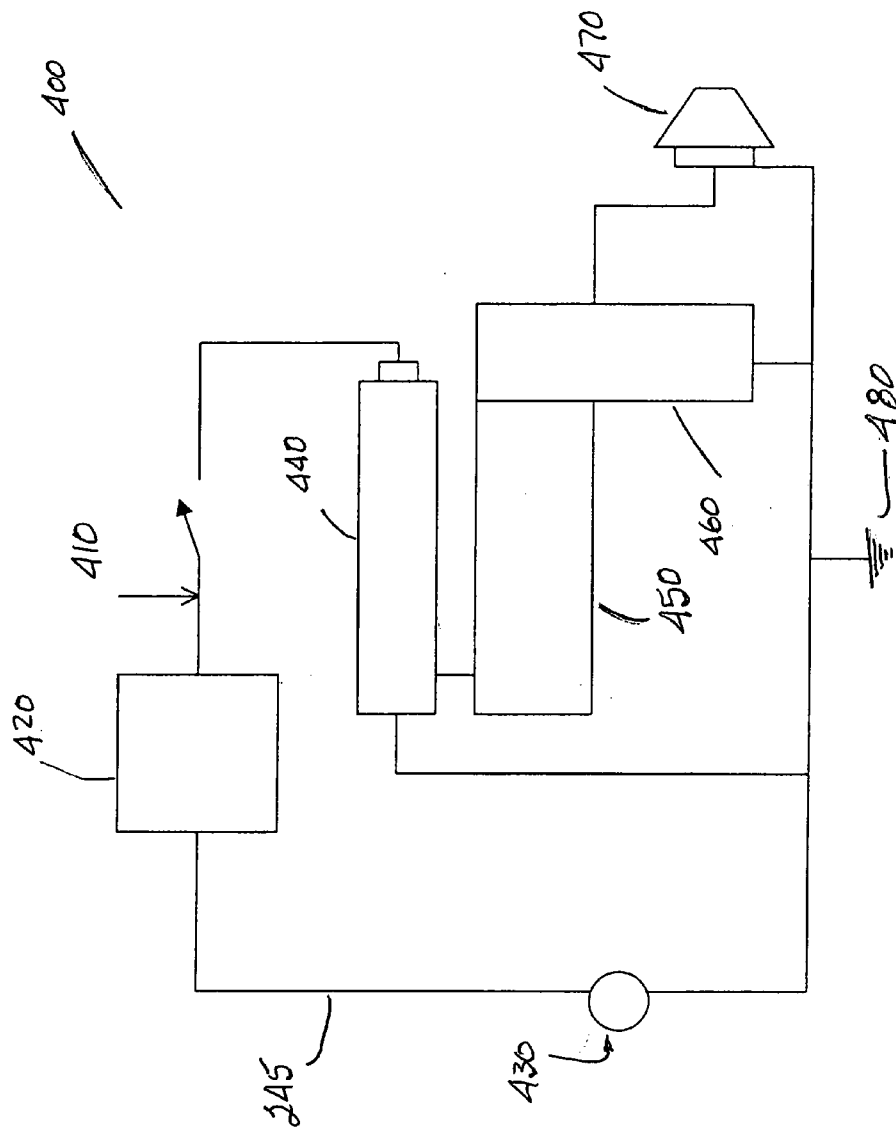

FIG. 4

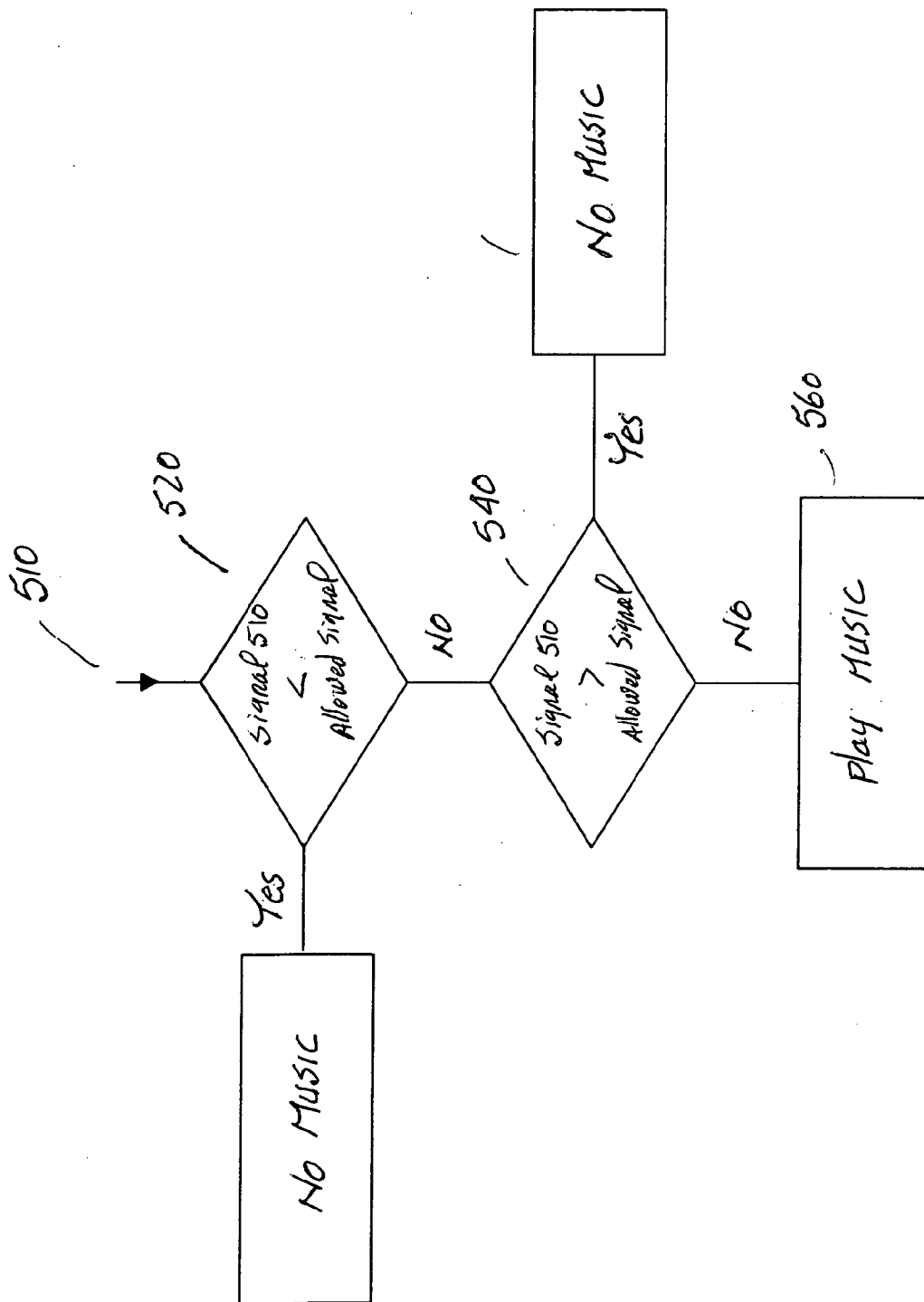

FIG. 5

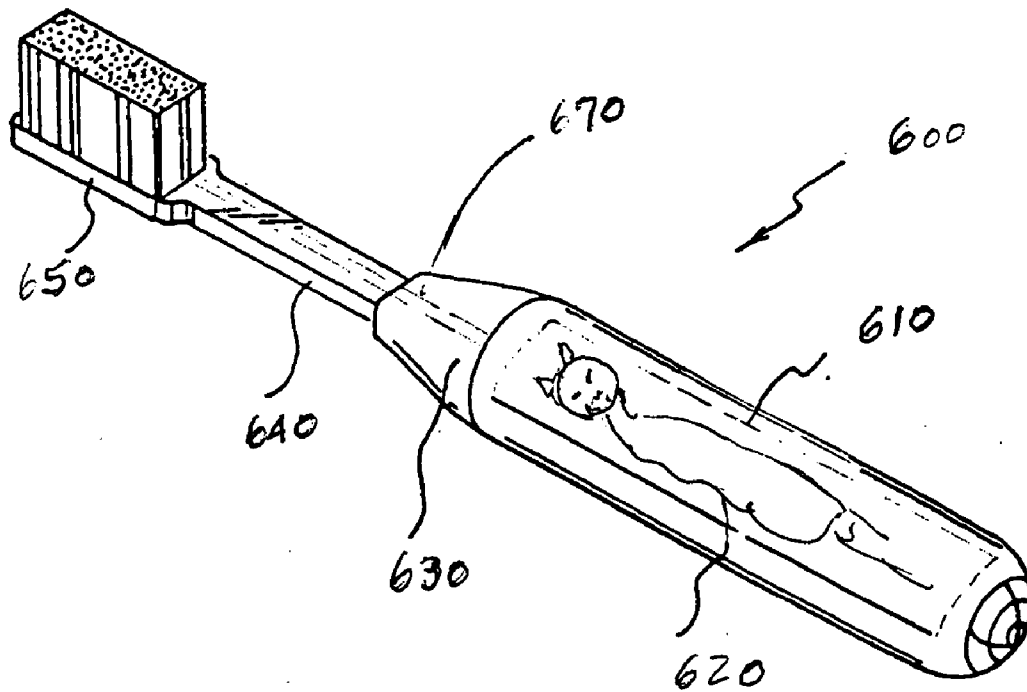

FIG. 6



## EFFICIENT TRAINING TOOTH BRUSH FOR CHILDREN

### FIELD OF THE INVENTION

[0001] The present invention relates to oral hygiene products. More specifically embodiments of the present invention relate to toothbrushes that develop habit in children to properly brush their teeth.

### BACKGROUND OF THE INVENTION

[0002] The use of toothbrush for oral hygiene is well known by the public, and is a prior art. The present state of art provides toothbrushes, which are, in general, a one-piece device consisting of a brush head and a handle. Recent innovation in the field provides detachable toothbrushes where the brush head separates from the handle, enabling the user to couple a plurality of brush heads to a brush handle to fulfill countless objectives and requirements of the users.

[0003] Recent innovations in this area have provided the public with music playing toothbrushes. A musical toothbrush generally includes sound generating components inside an enlarged handle and an ON/OFF switch that turns the music on or off. An example of music-playing toothbrush is described in U.S. Pat. No. 5,572,762 to Scheiner. This toothbrush includes a handle of standard dimensions, and a switch having a push button to turn on and off the music. An alternative toothbrush is described in U.S. Pat. No. 5,924,159 to Haitin. This toothbrush includes a motion-sensing device mounted on its handle and adapted to provide audible sound when toothbrush is in brushing use.

[0004] Some of these music-playing toothbrushes are battery powered and some are powered by employment of piezoelectric technique. A battery-powered toothbrush, generally, uses a conventional battery or a rechargeable battery. The recharging of the rechargeable battery is by means of a recharging base; the recharging base includes a cavity for receiving the toothbrush and is adapted to electrically couple with the toothbrush while receiving power to charge the rechargeable battery from conventional A/C outlets generally used by the public.

[0005] Regardless of the type of toothbrushes in the market, music playing or non-music playing toothbrush, a predominant requirement by parents with young children is to train their children to brush their teeth. Parents often have difficulty in encouraging their children to brush before bedtime or after meals. Parents with young children would appreciate a toothbrush that can help them develop tooth-brushing habit in their young children who often have tendency to evade tooth brushing.

[0006] There are also another group of children who are trained and retrained to brush their teeth but somehow they are disinclined to brush their teeth when their parents are not in attendance or when they are not being supervised. Parents have often used verities of methods to encourage their children to brush their teeth or make tooth-brushing exercise more attractive to those children who are disinclined to brush their teeth. Parents with young children would place a great value for a device, which can relieve them from continuously reminding and chasing children to brush their teeth at night or after meals. While myriad of designs have been developed and presented to market for public use to

fulfill these requirements yet parents are still in need of a means to encourage children to brush their teeth enthusiastically without reminder.

[0007] There is another problem associated with training a child how to brush their teeth and even among those adult who have gum disease. The problem is what pressure to apply on a toothbrush when brushing one's teeth. Several studies have arrived at the conclusion that excessive pressure during brushing may lead to recession on premolar, and also gingival recession, which exposes the underlying cementum, often leading to hypersensitivity, loss of aesthetics, and may be a factor in root caries and root surface abrasion.

[0008] To further encourage children to brush their teeth an easier method for applying toothpaste to toothbrush is helpful. Providing such method of applying toothpaste to a toothbrush will present a toothbrush as a toy for children who would otherwise treat a tooth brushing as a burden rather than an enjoyment.

[0009] Therefore, a need exist for an improved toothbrush that appears as a toy to the children while substantially relieving parents from continuously monitoring their children to brush their teeth. Still another need exist for a toothbrush that can warn a child or an adult with sensitive gum to apply more or less pressure on the toothbrush while they are brushing.

### SUMMARY OF THE INVENTION

[0010] Accordingly, embodiments of the present invention provide toothbrushes, which are attractive to children and help develop habit of tooth brushing in children. Another embodiment of the present invention provides a toothbrush, which appears as a toy, amuses children while they are brushing their teeth thus turning a burdensome tooth-brushing exercise into a pleasant practice. Additionally, another embodiment of this invention provides a pressure-sensing toothbrush, which discontinue the music when pressure applied to brush head is not within prescribed range. Still another embodiment of the present invention provides a method of dispensing toothpaste from a toy-like toothbrush handle assembly, which enables a young child to apply toothpaste on a toothbrush and brush his/her teeth while listening to a favorite music.

[0011] Yet in another embodiment of the present invention, a user of toothbrush subject of the present invention, applies pressure on a handle of the musical toothbrush while a plurality of bristles coupled to a toothbrush head of the musical toothbrush touch user's teeth. In response to the pressure applied by the user a pressure sensitive plate coupled to the plurality of bristles causes an optical signal. An optical to electrical converter generates an electrical signal and transmits the electrical signal to programmable controller. The controller passes the electrical signal to a music source if the strength of the electrical signal, a function of pressure applied to the toothbrush head, is within a pre-determined range. The electrical signal causes the music source positioned in the toothbrush handle to provide music.

[0012] These and other objects and advantages of the present invention will no doubt becomes obvious to those of ordinary skill in the art after having read the following

detailed description of the preferred embodiments which are illustrated in the various drawing figures.

#### BRIEF DESCRIPTION OF THE DRAWINGS

[0013] **FIG. 1A** illustrates front view of a prior art toothbrush.

[0014] **FIG. 1B** depicts side view of a prior art toothbrush.

[0015] **FIG. 1C** depicts a perspective view of a prior art toothbrush.

[0016] **FIG. 2A** illustrates a prior art musical toothbrush with detachable head and an ON/OFF switch to turn on or off the music.

[0017] **FIG. 2B** depicts a music playing toothbrush assembly comprising battery, music chip and a coupling component to receive A/C power from a rechargeable device (not shown).

[0018] **FIG. 3A** is an embodiment of the present invention with a pressure sensing plate adapted to receive pressure from a plurality of toothbrush bristles.

[0019] **FIG. 3B** depicts another embodiment of the present invention where a programmable controller controls transmission of electrical signal generated by an optical to electrical converter

[0020] **FIG. 3C** depicts the embodiment of the present invention in its assembled form.

[0021] **FIG. 4** is a block diagram of a circuit incorporated in an embodiment of the present invention that monitors pressure applied when brushing and plays music.

[0022] **FIG. 5** is a flow chart of steps performed in an exemplary toothbrush that warn a user when pressure is out of range and plays music when pressure applied to bristles is within range.

[0023] **FIG. 6** depicts an exemplary view of a toothbrush with toothpaste-dispensing handle and toothpaste reservoir where handle depicts different animal figures.

#### DETAILED DESCRIPTION OF THE INVENTION

[0024] Reference will now be made in detail to the preferred embodiments of the present invention, a toothbrush for improving children's' tooth-brushing habits, examples of which are illustrated in the accompanying drawings. While the invention will be described in conjunction with the preferred embodiments, it will be understood that they are not intended to limit the invention to these embodiments. On the contrary, the invention is intended to cover alternatives, modifications and equivalents, which may be included within the spirit and scope of the invention as defined by the appended claims. Furthermore, in the following detailed description of the present invention, numerous specific details are set forth in order to provide a thorough understanding of the present invention. However, it will be recognized by one of ordinary skill in the art that the present invention may be practiced without these specific details.

[0025] In the following detailed description of the present invention, numerous specific details are set forth in order to provide a thorough understanding of the present invention. However, it will be recognized by one skilled in the art that

the present invention may be practiced without these specific details or with equivalents thereof. In other instances, well known methods, procedures, components, and circuits have been described in detail as not necessarily obscure aspects of the present invention.

[0026] While this invention is susceptible of embodiment in many different forms, there is shown in the drawings and will herein be described in detail specific embodiment, with the understanding that the present disclosure is to be considered as an example of the principles of the invention and not intended to limit the invention to the specific embodiment shown and described. In the description below, like reference numerals are used to describe the same, similar or corresponding parts in the several views of the drawings.

[0027] Referring now to **FIG. 1A** front view of a prior art toothbrush **100**, which is in common use, is illustrated. Toothbrush **100** is a one-piece device including a toothbrush head **110** and a toothbrush handle **120**. Toothbrush head **110** includes a plurality of bristles **105** that are used for tooth brushing. Bristles **105** are designed to bend for gentle brushing and to reach deep between teeth.

[0028] **FIG. 1B** depicts side view of a prior art toothbrush **100**. It is appreciated that toothbrush handle **120** is coupled with toothbrush **110** with a relatively flexible connecting piece **130**.

[0029] **FIG. 1C** depicts a perspective view of a prior art toothbrush **100**.

[0030] **FIG. 2A** depicts a prior art musical toothbrush **200** with detachable toothbrush head **240**, a toothbrush handle **210** that includes an On/OFF switch **215** to turn on or turn off the music. Toothbrush head **240** and toothbrush handle **210** are coupled by use of coupling **270**.

[0031] Still referring to **FIG. 2A**, toothbrush handle **210** is a hollowed body formed from a light permeable material having a first and a second end. Toothbrush handle **210** is adapted to receive power supply **220** which may be a conventional alkaline battery or a rechargeable battery through opening **221** at the first end of toothbrush handle **210**. Toothbrush handle **210** is also adapted to receive a user insertable electronic music chip **229**, insertable through a chip insertion opening **230**. Also included in the handle is a music generating circuit (not shown) adapted to retrieve sounds from the user insertable music chip **229** and generating a music output signal to speaker **280**. It is appreciated that toothbrush handle **210** is adapted to include a plurality of electrical contacts **285** on the second end that is adapted to couple to recharging devices that are available in most electronic stores.

[0032] Coupling **270** has a first end receiving opening **260** and a second end receiving opening **290**. Toothbrush head **240** has a connecting portion **250** adapted to be received by coupling component **270** through first receiving opening **260**. Second receiving opening **290** of coupling **270** is adapted to receive toothbrush handle **210** to form an assembly as depicted in **FIG. 2B**.

[0033] **FIG. 2B** depicts music playing toothbrush **200** in its assembled form. The assembly as depicted in **FIG. 2B**, comprises battery **220**, music generating component **235**, speaker **236**, On/OFF switch **215**.

[0034] It is appreciated that ON/OFF switch 215 can trigger musical generating component 235 independent of application of pressure to bristles 205.

[0035] FIG. 3A is an embodiment of the present invention including toothbrush head 340, a pressure sensing plate 311 coupled to a plurality of bristles 310 and a converter adapted to convert optical signal to electrical signal.

[0036] Pressure sensing plate 311 may be made of a sac containing piezochromic material liquid crystal cholesterol ester. When pressure is applied in direction 330 to pressure sensing plate 311 a deformation of pressure sensing material takes place and change of color will appear. Converter 350 converts optical response due to application of pressure on pressure sensing material inside pressure sensing plate 311 to electrical signal. The strength of electrical signal thus generated is a function of pressure applied in direction 330 on the plurality of bristles 310 during the tooth brushing activity and is transferred to pressure sensing plate 311. The electrical signal thus generated is transmitted through conductor 345. It is appreciated that a safe pressure to be applied to user's gum during tooth brushing is suggested by the American Dental Association.

[0037] FIG. 3B depicts another embodiment of the present invention where programmable controller 355 controls transmission of electrical signal generated by converter 350. The pre-programmed controller 355 acts as a gate and may be programmed to pass electrical signals that fall within a pre-programmed range.

[0038] Electrical signal generated by converter 350 is directly proportional to the pressure applied to the plurality of bristles 310. The pre-programmed controller 355 can be programmed to pass electrical signals that fall within a range of electrical signal that is generated by converter 350 when pressure applied to the plurality of bristles 310 is within the pressure suggested by the American Dental Association.

[0039] Electrical signal passed through controller 355 triggers switch 356 and causes power source 258 to electrically couple with music circuit 335. Musical circuit 335 powered by power source 258 delivers music to the user of toothbrush as long as the pressure applied to the plurality of bristles 310 is within the range suggested by American Dental Association.

[0040] FIG. 3C depicts the embodiment of the present invention in its assembled form. The user of the musical toothbrush 300, after application of toothpaste on the plurality of bristles 310, commences tooth brushing activity by causing contact between the plurality of bristles 310 and his/her teeth and makes back and forth or up and down movement of the tooth-brush. According to this embodiment of the present invention, when pressure on direction 330 is within the pre-programmed range, as defined, musical circuit 335 is activated and provide an assortment of desired melodies for the user.

[0041] It is appreciated that when pressure is applied to the plurality of bristles 310 pressure sensitive plate 311 generates optical signal and converter 355 converts optical signal to electrical signal. The present embodiment is adapted to trigger music circuit 335 only when pressure on the plurality of bristles 311 falls within a safe range of pressure to be applied to the user's gum recommended by the American Dental Association.

[0042] It is further appreciated that pre-programmed controller 350 may be programmed to settings for lesser pressure where the user suffers from gum disease. The pre-programmable controller 350 may also be programmed for higher pressure when the plurality of bristles 311 are softer than standard softness available in the marketplace.

[0043] FIG. 4 is a block diagram of circuit 400 that monitors pressure applied during a tooth brushing activity. Pre-programmed controller 420 receives optical signal 409 from optical to electrical converter 430 through conductor 245 of FIG. 3. Pre-programmed controller 420 examines the strength of the electrical signal. When signal strength is within a predetermined range switch 410 closes and power supply 440 delivers electrical power to music source 450. Amplifier 460 then amplifies the musical signal and delivers the musical signal to speaker 470.

[0044] FIG. 5 is a flow chart of steps performed in an exemplary musical toothbrush where an optical signal converted to electrical signal is monitored and triggers activation of music circuit.

[0045] In step 520, electrical signal 510 is received and a first test of signal 510 takes place. If signal 510 is less than a predetermined range of electrical signals allowed to pass the programmable controller 355 of FIG. 3B no electrical signal is passed to music circuit 530. Music circuit 530 will not be triggered and no musical signal is generated.

[0046] In Step 540 electrical signal 510 is again tested and if electrical signal 510 is greater than the predetermined range of electrical signals allowed to pass the programmable controller 355 of FIG. 3B no electrical signal is passed to music circuit 530. However, if electrical signal 510 is within the pre-determined value programmable controller 355 passes electrical signal 510 to music circuit 530 and a favorite music will be played while the pressure applied to toothbrush head stays within maximum and minimum range.

[0047] FIG. 6 depicts another embodiment of the present invention where toothbrush 600 is a musical toothbrush as described in FIGS. 3, 4 and 5 and further includes toothpaste reservoir 610. To make the toothbrush 600 more appealing to children one face of handle depicts an animal figure. The animal figure is not limited and may be any known animal favored by a child. The animal can be used as dispensing mechanism and a user can apply pressure on any part of the animal and cause toothpaste to be dispensed through canal 670 to the base of toothbrush head 650. A user of toothbrush 600 may view a toothbrush 6 with toothpaste-dispensing handle and toothpaste reservoir with handle depicting different animal figures. FIG. 4 depicts a cross section of an embodiment of the present invention with pressure sensing device mechanically coupled with toothbrush bristles.

[0048] In summary, the embodiments of the present invention provide a toothbrush that appeals to children because a child can select his/her favorite figure on the toothbrush handle. Furthermore a child can select from a variety of music chip that may be a birthday song or a song from his/her favorite singer. The present invention further provides a means for forming tooth-brushing habit in children who are otherwise disinclined to brush their teeth before sleep or after meals. Additionally, the present invention provides a system of constant mentoring for controlling proper pressure on gums during tooth brushing.

[0049] The foregoing description of specific embodiment of the present invention has been presented for purpose of illustration and description. They are not intended to be exhaustive or to limit the invention to the precise form disclosed, and obviously many modifications and variations are possible in light of the above teaching. The embodiments were chosen and described in order to best explain the principles of the invention and its practical application, to thereby enable others skilled in the art to best utilize the invention and various embodiments with various modifications as are suited to the particular use contemplated. It is intended that the scope of the invention be defined by the claims appended hereto and their equivalents.

What is claimed is:

- 1. A musical toothbrush assembly comprising:
  - a) a toothbrush-head assembly comprising:
    - a. a first end and a second end wherein said second end includes at least one electrical contact;
    - b. a plurality of bristles positioned on said first end;
    - c. a pressure sensing plate coupled to said plurality of bristles for generating optical signal when receiving pressure from said plurality of bristles;
    - d. means for converting optical signals to electrical signals coupled to said pressure sensing plate;
  - b) a toothbrush handle comprising:
    - a. a front end and a back end wherein said front end is adapted to receive said second end of said toothbrush-head assembly and includes at least one electrical contact for receiving said electrical signal, and wherein said back end includes a plurality of electrical contacts;
    - b. a programmable controller having an input port and an output port, said input port is adapted to receive said electrical signal from said means for converting optical signal to electrical signal and said output port provides an output signal when said electrical signal from said output port is within a pre programmed range of electrical signal;
    - c. a music source electrically coupled to said output port of said programmable controller for providing music when receiving said output signals from said programmable controller; and
  - c) a battery recharging cradle including a toothbrush handle cavity containing a plurality of charger contacts at the bottom of said numerous charger contacts are adapted to electrically couple with said back end of said toothbrush handle.

- 2. A toothbrush assembly as described in claim 1 wherein plastic molding makes said toothbrush handle.
- 3. A toothbrush assembly as described in claim 2 wherein said toothbrush handle is a hollowed body adapted to receive at least one speaker to provide audio output signal.
- 4. A toothbrush assembly as described in claim 2 wherein said toothbrush handle is a hollowed body adapted to receive at least one battery to provide electrical power.
- 5. A toothbrush assembly as described in claim 2 wherein said toothbrush handle is a hollowed body adapted to receive at least one music chip.
- 6. A toothbrush assembly as described in claim 2 wherein said toothbrush handle is molded to resemble at least one pet animal.
- 7. A toothbrush assembly as described in claim 2 wherein said toothbrush handle is a hollowed body adapted to receive at least one tooth-paste cartridge.
- 8. A toothbrush assembly as described in claim 2 wherein said toothbrush handle is a hollowed body adapted to receive at least one music chip.
- 9. A toothbrush assembly as described in claim 2 wherein said toothbrush handle is molded to resemble an animal.
- 10. A method for developing tooth brushing habits in children comprising the steps of:
  - a. applying pressure on a handle of a musical toothbrush while a plurality of bristles coupled to a toothbrush head of said musical toothbrush touch user's teeth;
  - b. in response to step a, said pressure automatically transfers to a pressure sensitive plate coupled to said plurality of bristles causing an optical signal;
  - c. responsive to said optical signal a converter generating an electrical signal;
  - d. programming a programmable controller for transmitting said electrical signal to a music source when said electrical signal is within a range set by the user; and
  - e. said electrical signal causing said music source positioned in said toothbrush handle to provide music for said user.
- 11. A method for developing tooth-brushing habits in children as described in claim 10 wherein said music source provides music when said pressure applied to said handle of said musical toothbrush is within a pre-determined range.
- 12. A method for developing tooth-brushing habits in children as described in claim 11 wherein said range is determined by American Dental Association.
- 13. A method for developing tooth-brushing habits in children as described in claim 12 wherein said electrical signal is not transmitted to said music source when said pressure is not within said range.

\* \* \* \* \*