

Feb. 26, 1929.

1,703,670

A. R. HOEFT

ADJUSTABLE ROOF SADDLE FOR STOVEPIPES

Filed Nov. 12, 1927

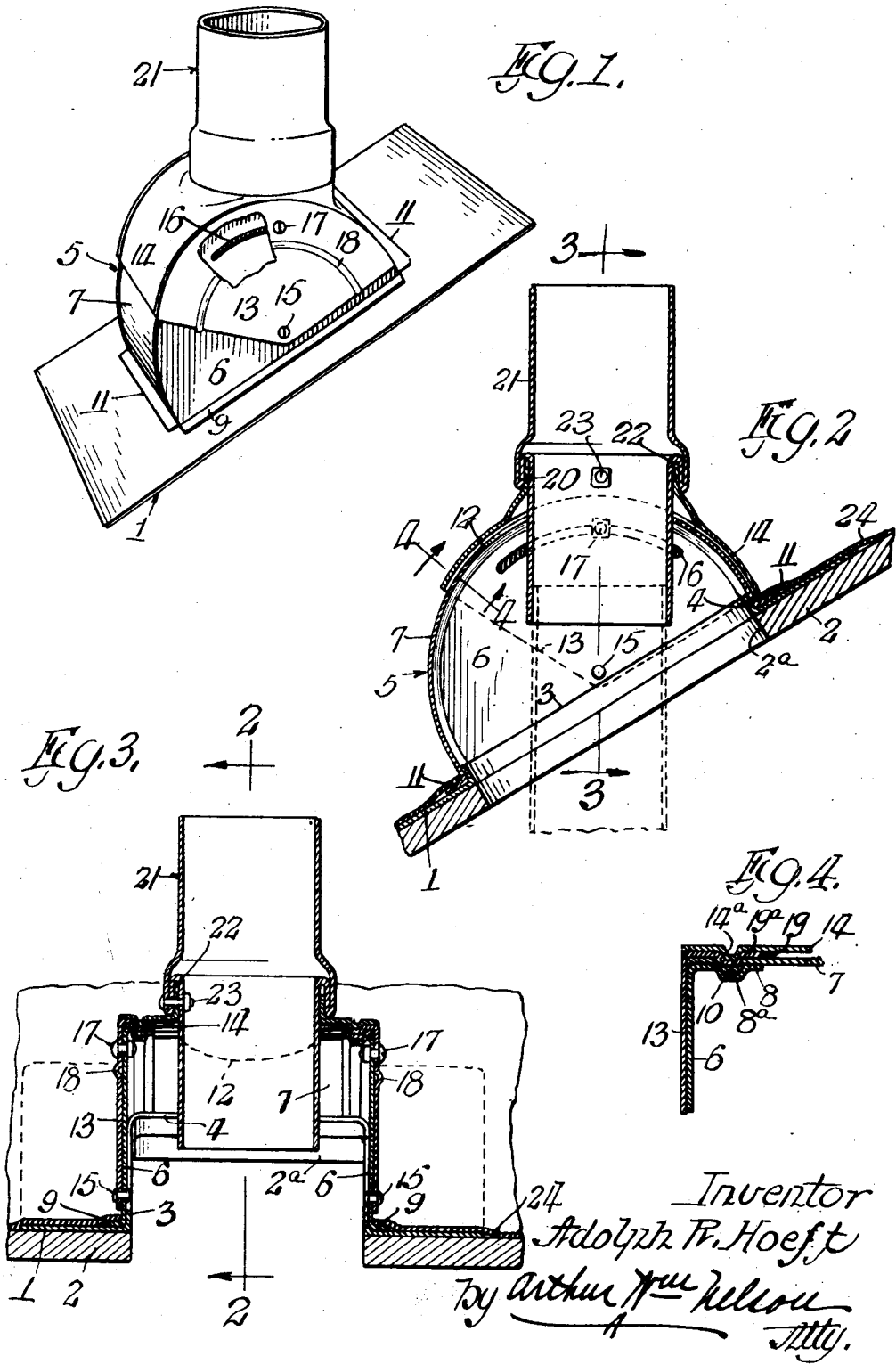

UNITED STATES PATENT OFFICE.

ADOLPH R. HOEFT, OF EVANSTON, ILLINOIS, ASSIGNOR TO HOEFT & COMPANY, INC.,
OF NORTH CHICAGO, ILLINOIS, A CORPORATION OF ILLINOIS.

ADJUSTABLE ROOF SADDLE FOR STOVEPIPES.

Application filed November 12, 1927. Serial No. 232,741.

This invention relates to improvements in adjustable roof saddles for stove pipes and it consists of the matters hereinafter described and more particularly pointed out in the appended claims.

The primary object of the invention is to provide a saddle of this kind which is readily adjustable for use with a roof of any inclination from an almost flat roof to one of a one-half pitch and which is not only wind tight but is storm and rain proof.

A further object of the invention is to provide an improved guide construction between the housing and chimney or stove pipe hood which rigidifies the entire structure and also to provide an improved weatherproof connection between the hood and stove pipe.

These objects of the invention as well as others, together with the many advantages thereof will more fully appear as I proceed with my specification.

In the drawings:

Fig. 1 is a perspective view of a roof saddle embodying therein, the preferred form of my invention.

Fig. 2 is a longitudinal vertical sectional view through the same on an enlarged scale as taken on the line 2—2 of Fig. 3.

Fig. 3 is a transverse vertical sectional view through the same as taken on the line 3—3 of Fig. 2.

Fig. 4 is an enlarged detail sectional view through a part of the saddle as taken on the line 4—4 of Fig. 2.

Referring now in detail to that embodiment of the invention illustrated in the accompanying drawings: 1 indicates as a whole the sheet metal roof plate of the saddle, which plate is rectangular in plan and is fixed to a pitched deck 2 of a roof or the like in any suitable manner. Said plate is of a greater dimension in one direction than the other and is arranged with its length parallel with the pitch of the roof deck. In said plate is provided an elongated rectangular opening defined by upwardly extending integral side and end flanges 3 and 4 respectively, said opening registering with another opening 2^a in the roof deck as best shown in Figs. 2 and 3. Associated with said opening is a semicylindrical sheet metal housing 5 comprising upright side walls 6—6 and a curved or arcuate top wall 7 connecting the similarly curved or arcuate margins of said side walls together, which margins extend through an arc ap-

proximating 180°. Along each arcuate margin of the side walls 6—6 and extending the full length thereof, is an inwardly extending flange 8 with an upwardly opening bead 8^a therein and along the straight bottom margin thereof is an outwardly extending flange 9. The lateral margins of the curved top wall 7 are each formed with a similar upwardly opening bead 10 that seats in the bead 8^a of the side wall flange 6 and said beads are spot welded together, while the ends of said top wall are bent over to there form outwardly extending flanges 11—11. By this grooved flange and bead construction the housing is indeed rigidified and a weather proof joint is had between said side walls and top wall. In said top wall between its ends is provided a substantially large opening 12, the purpose of which will later appear. The housing above described seats upon the roof plate 1 about the upturned flanges 3 and 4 thereof while the flanges 9 and 11 of the housing are secured in any suitable manner to said roof plate about said upturned flanges.

Associated with said housing is a hood 80 adapted to fit over a part thereof and said hood is so pivoted to the housing as to be swung in the plane of the side walls 6—6 into different angular positions with respect to the roof plate. Said hood comprises spaced upright, segmentally shaped side walls 13—13 and a curved top wall 14 concentric with the curved top wall of the housing. The apex or pointed ends of said side walls 13—13 of the hood are pivoted as by means of rivets to the side walls 6—6 of the housing at points 15—15 which are coincident with the axis of the curved top wall of said housing. In the housing side walls 6 are arcuate slots 16—16 concentric with said pivot points 15—15 and short bolts 17—17 carried by the side walls of the hood extend through said slots to secure the hood in the desired angular position. In said segmental side walls of the hood, concentric ribs 18 are provided to stiffen the same and the arcuate slots 16 are of such length that at no time are they exposed no matter what angular position the hood happens to be in with respect to the housing.

The arcuate top margins 19 of the side walls 13 of the hood are each provided with an inturned flange, each having an upwardly opening grooved bead 19^a therein, while the top wall of said hood has its lateral margins

complementally formed to provide grooved beads 14^a that fit within and are spot welded to the beads of the flanges on said side walls 13—13. This construction rigidifies the hood and provides interengaging tongue and groove bearing for the hood upon the housing as is most apparent from Fig. 4.

In the top wall of said hood midway between its ends is provided an integrally flanged upwardly extending collar 20 to receive a smoke or stove pipe section 21. In making up said pipe and while it is in the "flat" I provide a zig-zag fold which in the rolling of the pipe forms a downwardly facing annular groove 22 therein about midway between its ends that receives the collar 20 on the hood. A bolt 23 is passed through the pipe and collar at this point to secure them together. This arrangement prevents any possibility of the entrance of the weather elements at this point and at the same time stiffens the pipe structure. Other pipe sections may be attached to said top and bottom ends of the smoke pipe as is apparent, the opening 12 in the top wall of the housing permitting the bottom end of the pipe 21 to pass therethrough.

When in use upon a roof, the roof covering or shingles 24 cover the roof plate 1 and housing flanges 9 and 11 and portions of said roof covering may be "flashed" about the bottom end of the housing. By the arrangement described, an absolutely weather proof construction is provided, and one which may be shipped "knocked down" to save transportation space. The improved roof saddle is all readily made of sheet metal and may be quickly assembled and is strong and rigid.

While in describing my invention, I have referred in detail to the form and arrangement of the parts thereof, the same is to be considered as by way of illustration only and

not by way of limitation except as may be pointed out in the appended claims.

I claim as my invention:

1. A roof saddle embodying therein a roof plate having an upwardly directed, integral flange defining an opening therein, a housing fixed at its bottom to said plate about said flange and including side walls and an arcuate top wall, a hood having an arcuate top wall and segmental side walls pivoted to said housing on an axis concentric with said top wall of the housing, said arcuate top wall of the housing and said arcuate top wall of said hood having interengaging grooves and beads in their lateral margins, said top wall of the hood also having a flanged pipe receiving collar thereon, and interengaging means between the side walls of said housing and hood respectively for securing the hood in the desired adjusted angular position with respect to the housing.

2. A roof saddle embodying therein a roof plate having an opening therein, a housing fixed to said plate to enclose said opening and including side walls and an arcuate top wall, a hood having segmental side walls pivoted to the side walls of said housing about an axis coincident with the axis of the arcuate top wall concentric with the top wall of the housing, means on said arcuate top walls of said housing and hood respectively providing interengaging grooves and beads therebetween, there being an arcuate slot in each side wall of the housing and means carried by each segmental side wall of the hood and engaging in the slots in said side walls of the housing, for securing the hood in the desired angular position upon the housing and a pipe receiving collar on the top wall of said hood.

In testimony whereof, I have hereunto set my hand, this 5th day of November, 1927.

ADOLPH R. HOEFT.