

(No Model.)

G. S. & R. C. ANDERSON.
CUTTER CYLINDER FOR FEED CUTTERS.

No. 523,876.

Patented July 31, 1894.

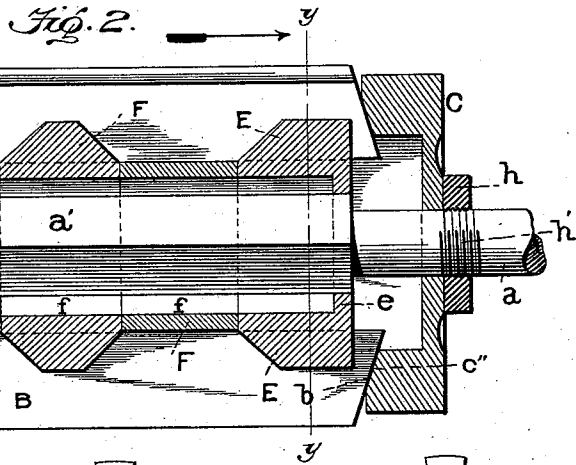
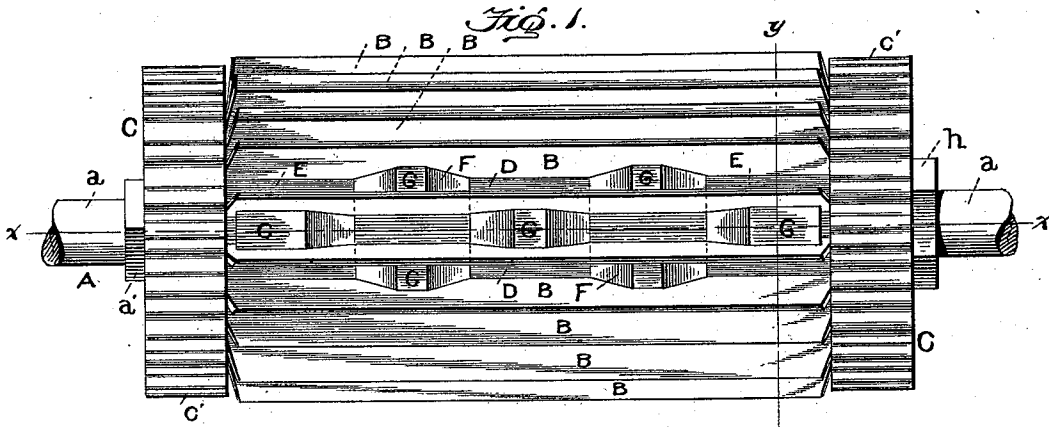

Fig. 3.

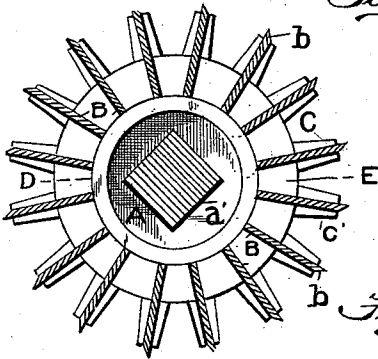

Fig. 4.

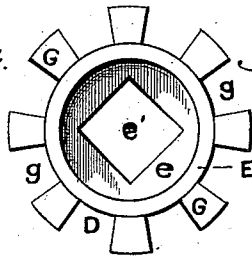

Fig. 5.

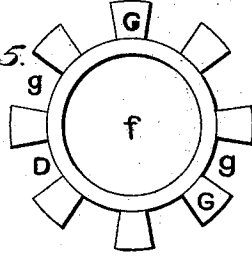

Fig. 7.

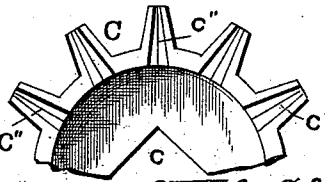
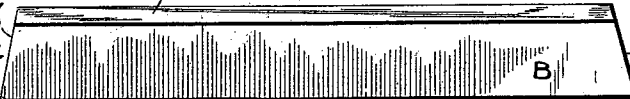

Fig. 6. George S. & Robt. C. Anderson.
Inventors.

Witnesses:

W. C. Schubert
W. J. Anderson



by
Edson Bros.
Attorneys

UNITED STATES PATENT OFFICE.

GEORGE S. ANDERSON AND ROBERT C. ANDERSON, OF JEFFERSONVILLE,
INDIANA.

CUTTER-CYLINDER FOR FEED-CUTTERS.

SPECIFICATION forming part of Letters Patent No. 523,876, dated July 31, 1894.

Application filed January 12, 1894. Serial No. 496,648. (No model.)

To all whom it may concern:

Be it known that we, GEORGE S. ANDERSON and ROBERT C. ANDERSON, citizens of the United States, residing at Jeffersonville, in the county of Clark and State of Indiana, have
5 invented certain new and useful Improvements in Cutter-Cylinders for Feed-Cutters; and we do hereby declare the following to be a full, clear, and exact description of the invention,
10 such as will enable others skilled in the art to which it appertains to make and use the same.

Our invention relates to improvements in cutter cylinders, and more especially to cutters of that class which are employed in machines for cutting feed and fibrous materials, and the object of the invention is to provide
15 a simple, cheap and compact construction by which the blades or knives are securely clamped in position and which can be readily taken apart for the purposes of sharpening or replacing the knives.

With these ends in view, our invention consists of the construction and combination of parts which will be hereinafter fully described
20 and claimed.

We have illustrated the preferred embodiment of our improved cutter cylinder in the accompanying drawings, forming a part of
25 this specification, and in which—

Figure 1 is a plan view. Fig. 2 is a longitudinal sectional view through the cutter cylinder on the plane indicated by the dotted line *xx* of Fig. 1. Fig. 3 is a vertical transverse sectional view on the plane indicated
30 by the dotted line *yy* of Figs. 1 and 2. Fig. 4 is a detail view of the end section of the cutter roll or cylinder, and Fig. 5 is a like view of one of the intermediate sections of said roll or cylinder. Fig. 6 is a detail view of one of the knives or blades. Fig. 7 is a detail view
35 of one of the gears, looking at the inner face thereof, to show the radial grooves or channels in which the ends of the knives or blades are designed to be fitted.

Like letters of reference denote corresponding parts in all the figures of the drawings, referring to which—

A designates the shaft of the cutter cylinder, which shaft has the cylindrical journals
40 *a* at the ends thereof and which has the square,

polygonal or other angular part, *a'*, between said cylindrical journals, said shaft being forged or otherwise wrought from a single
45 piece of metal.

B designate the blades or knives, *C* the heads or gears, and *D* is the roll or cylinder which is constructed of end and intermediate sections to hold the blades or knives, the latter being clamped between said sections of the
50 roll and the heads or gears in a manner to securely hold them in place without the use of fastenings and to permit the parts to be readily taken apart for sharpening the knives or for renewing any of the parts in case of
55 breakage or damage thereto.

The sections of the cutter roll or cylinder are indicated at *E*, *F*, on the drawings, the former denoting the two end sections or members and the latter the intermediate members
60 or sections which are disposed between the end sections, *E*. Each section or member of the roll is cast in a single piece of metal, and each member is provided on its periphery with a number of lugs, *G*, which are spaced
65 at suitable intervals to provide a number of seats, *g*, between said lugs; and each of the lugs has its sides beveled or inclined toward the peripheral face of the section, so that the lugs have a dovetailed form in cross section.
70 The end sections or members, *E*, of the roll are each cast with a head, *e*, in which is formed an angular or polygonal opening, *e'*, which conforms to the cross sectional form of the shaft, but the intermediate sections *F* of
75 the roll are made or formed with circular openings, *f*, which are of greater diameter than the shaft, see Fig. 5.

By reference to Fig. 4 of the drawings, it will be noted that the end sections, *E*, of the
80 roll are provided with circular holes for a portion of their length, and that the head *e* with the angular opening is only at one end of the section, whereby the end sections are adapted to fit upon the angular part of the
85 shaft *A* at their ends while they do not contact with the shaft for the remaining portion of their length. The intermediate sections, *F*, of the roller do not contact with or bear upon angular part of the shaft, but they are
90 clamped and held between the end sections, *E*, *E*. The object of making these interme-

diate sections E with enlarged central openings and to have them free from contact with the shaft is to enable said sections to adjust themselves to the knives in case the shaft employed is not straight. If a shaft was employed which was deflected—bent or curved—out of a straight line, and the intermediate sections E constructed to fit snugly upon said shaft, the knives would be projected at the middle portion and hence the cutter cylinder would ride or bear at the center thereof instead of touching on the ends, and to overcome these defects in the practical use of our cutter cylinder, we employ the intermediate sections E with holes of such diameter that the inner walls of said sections do not contact with the shaft but are clamped between the end sections, whereby the intermediate sections are free to accommodate themselves to a shaft whether the latter be a straight bar of metal or whether it is curved or bent slightly out of a straight line. Another advantage of this construction is that we are able to make the roll somewhat lighter without sacrificing strength and stability of the structure.

The heads or disks C are each made or cast in a single piece of metal with an angular, square or polygonal opening *c* at the center thereof, and these disks or heads are provided on their peripheries with the gear teeth, *c'*. Each disk is further provided on its inner face, or on that side thereof next to the ends of the blades or knives B, with the radial grooves or channels which are extended or formed on the inner sides of the teeth, *c'*, and these channels or grooves gradually increase in depth from the outer extremities of the teeth, *c'*, toward the axis of the disks, to accommodate the beveled ends of the blades or knives. These knives B are each made of a single piece of metal, preferably knife metal, suitably tempered, and the outer longitudinal edge of each blade is beveled to a cutting edge, *b*, while the ends of the blade are beveled from the inner edge which rests upon the seats of the sections, E, F, to the outer sharpened edge, *b*, as indicated at *b'*, in Figs. 2 and 6.

One of the gears C is fitted against a fixed collar, *h*, on the shaft which is preferably held thereon by means of screw-threads formed in an opening therein and fitted to engage with similar threads, *h'*, formed on the shaft, see Fig. 2. After the sections of the roll D having the knives between its dovetailed lugs has been fitted on the shaft, the other head C is slipped on the shaft to bear against one end of the blades, and the parts are securely held together by means of a key or pin, I, which is passed through a transverse opening, *i*, in the shaft, as shown by Fig. 2. The beveled ends, *b'*, of the knives or blades project beyond the end sections, E, E, of the roll, and these beveled ends are fitted in the radial grooves or channels, *c''*, on the inner faces of

the gears, C, C, and as the gears are held between the collar *h* and the key I, they press and bear against the ends of the blades and against the end sections E, E, of the roll to clamp the parts in place and hold the blades against endwise movement on the shaft.

The blades are fitted on the seats, *g*, of the roll sections and between the dovetailed lugs G on said roll-sections. The sections are arranged so as to alternate with each other, that is to say, the lug G on one section or member is in line with the space between two adjacent lugs G on the contiguous section or sections, as indicated clearly by Figs. 1 and 2 of the drawings, and the blade is held against the opposite beveled faces of the lugs so as to be clamped by and between the same against lateral displacement. The squared or polygonal part *a'* serves to hold the end sections E, E of the roll or cylinder against rotation on the said shaft, and these end sections E, E, are firmly clamped upon the intermediate sections F of the roll by the pressure of the disks or gears C, C, which are forced against the end sections E, E and against the ends of the knives or blades B by the wedging action of the key I and nuts *h* as indicated in Fig. 2 of the drawings.

It will be seen from the foregoing description taken in connection with the drawings that our improved cutter cylinder consists of a number of parts which, when properly assembled, operate to clamp and hold the blades against both lateral and endwise displacement, and without the use of transverse or other fastenings through the blades, whereby the parts can be readily separated to permit the knives to be detached for the purpose of sharpening the same, or for replacing any of the parts when broken or damaged.

The parts, except the blades and the shaft, are all of cast metal, which enables us to produce a cutter cylinder at a low cost and which at the same time is simple and durable in construction.

The blades or knives of the cutter cylinder are arranged in line with the gear teeth on the parts, C, C, and the beveled or sharpened edges, *b*, of said knives extend or project beyond the outer ends of said gear teeth to enable the knives to properly act upon the material as it passes between the rollers of the cutting box.

Although we have designed our improved cutting cylinder for use in a cutting box for feed or other fibrous materials yet we do not strictly confine ourselves to the use of the improved cylinder in this class of machinery, as the cylinder may be advantageously used in other machines in which a cylinder is provided with radial blades.

It is evident that a skilled mechanic can modify and change the construction herein shown and described as an embodiment of our invention in minor details and in the form and proportion of parts without departing

from the spirit or sacrificing the advantages of the invention, and we therefore hold ourselves at liberty to make such alterations as fairly fall within the scope of our invention.

5 One of the principal advantages due to our construction is that the knives or blades are held firmly in position and prevented from crushing down when the cutter is in action. In the common style of wooden roller having knives seated thereon, the blades are crushed
10 down and deflected from position, which is a serious objection to the use of wooden rollers; but in our invention, the blades have firm bearings on the roller and they are clamped
15 both transversely and longitudinally by the bearings G, and the gears or disks so that said blades cannot become displaced on the roller or cylinder.

Having thus fully described our invention, 20 what we claim as new, and desire to secure by Letters Patent, is—

1. In a cutter cylinder, the roll divided transversely into a series of sections E, F, each provided with a series of radial lugs G and
25 said sections arranged to have the lugs alternately disposed on adjacent sections, in combination with a shaft extending through said sectional roll, heads or gears fixed to the shaft and clamping the sectional roll between them-
30 selves, and longitudinal blades seated on the peripheries of the roll-sections, between the lugs thereof to be clamped laterally thereby, and held between said heads against longitudinal displacement, substantially as and
35 for the purposes described.

2. In a cutter cylinder, the roll divided transversely into a series of sections each provided with a series of radial lugs G of dovetailed form and spaced to provide the peripheral seats and said sections arranged in relation to each other to alternately dispose the
40 lugs on adjacent sections, in combination with the blades or knives seated on the peripheral seats of said roll sections and clamped laterally by the dovetailed lugs, a shaft, and heads or gears which hold the roll sections and blades together, substantially as and for the
45 purposes described.

3. In a cutter cylinder, the combination
50 with a central shaft, of a knife-bearing roll made up of a series of sections of which the end sections are supported directly on the shaft and the intermediate sections are of such internal diameter as to be clamped between
55 the end sections without having contact with the shaft, and each section provided with the radial spaced lugs and the peripheral seats, knives fitted on said seats of the roll-sections and clamped laterally between the lugs, and
60 heads or gears fixed on the shaft to clamp the

sectional roll and the knife, substantially as and for the purposes described.

4. In a cutter cylinder, the combination with a polygonal shaft, of the knife-bearing roll composed of the end sections E having
65 the polygonal openings to receive the shaft and the intermediate sections F having the enlarged openings and fitted between the end sections, and each section provided with the peripheral seats and the radial lugs G between
70 said seats, the blades seated between said lugs and having the beveled ends extending beyond the end sections E, and the heads or gears fixed on the shaft and provided with the radial grooves to receive the beveled ends
75 of the blades, substantially as described.

5. A cutter cylinder comprising the shaft, the knife-bearing roll divided transversely into a series of sections E, F of which the end sections are held on the shaft and the inter-
80 mediate sections clamped by and between the end sections, and said sections provided with the radial, spaced, dovetailed lugs G disposed alternately in relation to each other, the blades seated on the roll sections and clamped
85 between the lugs, the heads or gears fitted on the shaft and bearing against the sectional roll and the knives, the nut *h* against which one head or gear bears, and the key I fastened to the shaft to bear against the other head or
90 gear, substantially as described.

6. In a cutter cylinder, the combination with a shaft, of a roll divided transversely into a series of sections which are fitted around
95 the shaft without contact with the same and constructed on their outer surfaces with projections adapted to bear laterally against the sides of blades or knives, the blades or knives fitted between said clamping projections of
100 the roll sections, and means to clamp the roll sections laterally upon one another and to hold the blades against endwise displacement, substantially as described.

7. In a cutter cylinder, the combination
105 with a central shaft, of a divided roll having its end sections fitted on the shaft and its intermediate sections clamped between the said end sections and free from contact with the shaft, the blades seated upon the roll, and disks or gears which bear against the end sections of the roll and retain said blades in place,
110 substantially as described.

In testimony whereof we affix our signatures in presence of two witnesses.

GEORGE S. ANDERSON.
ROBERT C. ANDERSON.

Witnesses:

WILLIAM H. LANG,
CHARLES ANDERSON.