

April 2, 1963

A. W. BROWN ET AL

3,083,377

EXHAUST ATTACHMENT FOR TOILET BOWLS

Filed July 24, 1961

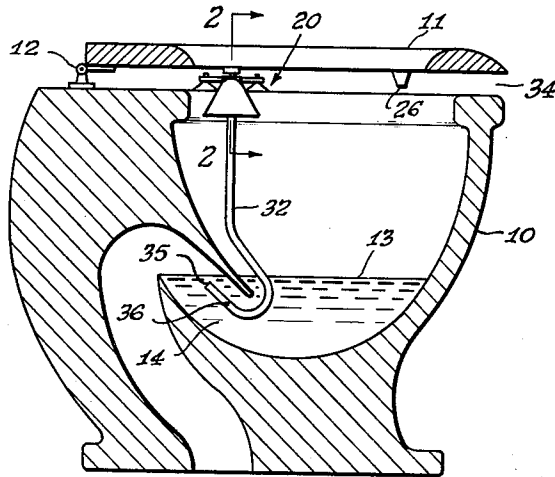

FIG. 1

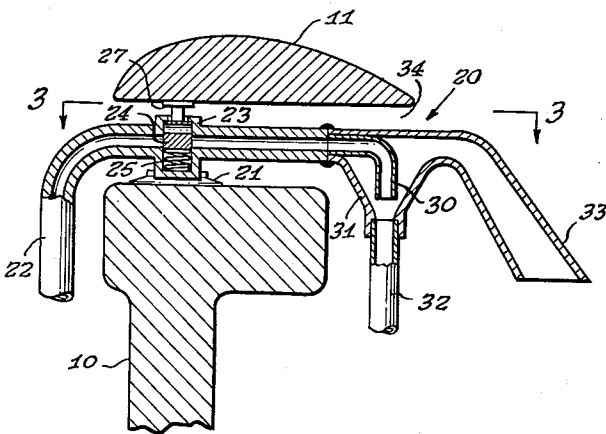

FIG. 2

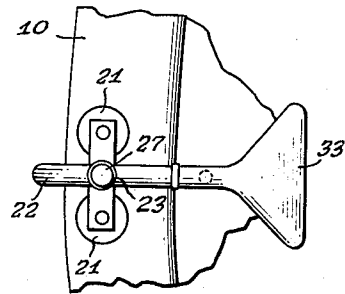

FIG. 3

Inventors
Arthur W. Brown
Kenneth E. Pope

By Edward L. Amoretta
Agent

1

3,083,377

EXHAUST ATTACHMENT FOR TOILET BOWLS
 Arthur W. Brown, 4019 Martin Road SW., and Kenneth
 E. Pope, 2720 Alvarado Drive NE., both of Albuquerque,
 N. Mex.

Filed July 24, 1961, Ser. No. 126,071
 5 Claims. (Cl. 4-215)

Our invention relates generally to toilets, and more particularly to an attachment for exhausting objectionable odors from the air space over the water in the toilet bowl.

Bathroom ventilation has long been a problem, since the odors normally associated with toilets are objectionable and should be removed from the vicinity as rapidly as possible. Ventilating systems now in common use usually are mounted in the ceiling of the bathroom and attempt to exhaust the air from the bathroom in order to remove the objectionable odors. In order to do the job efficiently, however, the exhaust unit must have a considerably higher capacity than is economically feasible. The result is that low capacity fans are used with mediocre results. Also, the arrangement of the fan in the ceiling of the bathroom does the toilet user little good, since the odors emanating from the toilet are drawn past the user before they can be exhausted from the room along with the rest of the room air.

It is a general object of our invention to provide a toilet exhaust attachment which removes odors from the toilet bowl and discharges them on the outlet side of the water trap in a sewer system without the odors ever having been released to the air within the bathroom.

Briefly, our invention accomplishes this object by means of an exhaust system which may be mounted on the rim of the toilet bowl. The system exhausts the air from the bowl above the water and discharges it on the outlet side of a water trap which may be associated with the bowl. In a preferred embodiment to be later described, the air is exhausted by means of a water jet operating through a venturi, the outlet of which extends through the water in the bowl to the outlet side of the bowl trap. Since a relatively small volume is exhausted, the exhausting means may be small and comparatively economical to build.

A better understanding of our invention may be had by reading the more detailed description to follow in conjunction with the claims and the attached drawing in which:

FIG. 1 is a sectional view of a toilet bowl showing our invention installed therein;

FIG. 2 is a sectional view of the preferred embodiment of our invention, taken along the lines 2-2 of FIG. 1; and

FIG. 3 is a top view of the installation taken along the lines 3-3 of FIG. 2.

Referring now to the drawing, toilet bowl 10 has the usual seat 11 attached thereto by hinge 12. Water 13 is contained in the lower portion of the bowl, including S-shaped trap 14 which is necessary to prevent sewer gas from rising into the toilet from the remainder of the sewer system. The outlet side of the trap is that portion within which an object lighter than water will, if released, progress toward the sewer rather than into the toilet bowl. Water jet air pump 20 is mounted on the rim of the toilet bowl by means of suction cups 21. Water line 22 extends to the pump from a suitable connection in a pressurized water system. It may be convenient to connect the line to the faucet or valve usually located behind the toilet in the water line to the toilet tank. Valve 23 includes a plunger 24 normally held by spring 25 in a position to block water line 22. This posi-

2

tion is coincident with seat 11 either being in a raised position or unoccupied as shown.

When a person sits on seat 11 the added weight forces the lid downward slightly until button 26 rests against the bowl rim. This movement of the seat against member 27 depresses plunger 24, compressing spring 25 and opening water line 22 so that water flows therefrom into nozzle 30. The nozzle is located within a venturi formed in conjunction with housing 31 of the pump. By venturi action, water forced out nozzle 30 into discharge tube 32 forms a partial vacuum within the venturi, drawing air from the toilet bowl through downwardly extending intake 33. This in turn creates a partial vacuum within bowl 10 so that room air enters the bowl through the aperture 34 between the seat and the bowl rim.

The evacuated air is mixed with water within the pump and is discharged through tube 32 at the outlet side of trap 14 at location 35, preferably under water. The air, together with the objectionable odors, either remains mixed with the water and flows downstream in the sewer system, or leaves the water and is vented to the atmosphere through the vent (not shown) associated with the toilet. Discharge tube 32 more or less follows the curvature of trap 14, so that water remaining in the tube after pump operation acts as a trap for sewer gas, apart from the water in trap 14. However, if the pressure in water line 22 is high no water will remain in the tube after pump operation. For safety, then, it is best to install the tube with its outlet end 35 below the surface of the water. As a second precaution a perforation 36 may be provided in discharge tube 32 some distance from end 35 within the outlet side of trap 14. This allows water from the trap to enter the tube if end 35 should protrude above the water surface, providing an underwater discharge means at all times.

Since the toilet exhaust goes into action only when operated by the weight of a person sitting on the toilet seat, or an equivalent weight, there is no wastage of water when ventilation is not required. As long as a person, or an equivalent weight, remains on the seat the odoriferous air within the toilet bowl is continuously exhausted into the sewer system without ever entering the bathroom proper.

It is conceivable that other forms of exhaust could be used, such as an electric fan mounted within the bowl, but the water-operated pump shown involves no electrical hazards, real or imaginary, and is a much more economical unit to build and to operate. Also, the pump emits a pleasant sound which masks out other less pleasant sounds normally associated with the use of toilets. The toilet exhaust is designed for easy installation by the do-it-yourselfer, since all that is required is the attaching of suction cups to the toilet bowl rim, and the connection of the water line to a suitable pressurized water source. Although the embodiment shown includes pump, intake and valve, all mounted on the toilet bowl, it is obvious that if more convenient the pump, or other air exhausting means, could be mounted separate from the toilet, the intake remaining within the bowl. Also, the discharge tube can terminate elsewhere in the sewer system at the outlet side of a trap other than the toilet trap. Valve 23 may be located elsewhere and controlled by other than seat pressure.

A preferred embodiment of our invention has been described without intent to limit patent protection thereto. The sphere and scope of the invention is outlined in the claims below.

We claim as our invention:

1. An exhaust attachment for toilet bowls, comprising: air moving means;
- air intake means associated with the air moving means for exhausting the air space of the toilet bowl;

3

- a tube extending from the air moving means to the outlet side of the toilet water trap, said tube having a perforation some distance from its discharge end within the outlet side of the toilet water trap;
- control means actuated by pressure on the toilet seat for initiating exhaust of the air space when a person sits on the seat;
- and means for mounting the attachment on the rim of the toilet bowl.
2. An exhaust attachment capable of unitary installation on the rim of a toilet bowl, comprising:
- an air pump;
- an air intake associated with the pump and extending therefrom into the air space over the water in the toilet bowl;
- means located between the toilet seat and rim responsive to the weight of a person sitting on the seat for actuating the pump;
- a discharge tube connected to the pump and extending therefrom through the toilet trap to the outlet side thereof;
- and means for holding the attachment on the rim without modification thereto.
3. An exhaust attachment for toilet bowls comprising:
- a water jet air pump mounted on the rim of a toilet bowl by a pair of suction cups;
- means extending between the seat and the rim, connecting the pump to a pressurized water supply external to the toilet;
- an air intake attached to the pump within the air space of the toilet bowl;
- discharge means mounted on the pump downstream from the jet and terminating on the outlet side of the toilet water trap;
- and a normally closed valve intermediate the water supply and the pump, opened by pressure upon the toilet seat.
4. In a toilet of the character described, an exhaust attachment comprising:

4

- a water line extending from an external source of pressurized water, intermediate the toilet seat and bowl rim, to immediately inside the bowl;
- a normally closed valve mounted in the water line intermediate the seat and the rim, opened by downward pressure on the seat;
- a water jet air pump connected to the water line inside the bowl;
- a downwardly extending air intake attached to the pump for exhausting air from the toilet bowl;
- a discharge tube attached to the pump and extending downwardly through the trap to the outlet side thereof;
- and suction cup means for mounting the attachment as a unit on the rim of the toilet bowl.
5. An exhaust attachment for mounting on the rim of a toilet bowl, comprising as a unitary structure:
- a water line for extending through a space between the toilet seat and the rim;
- a valve mounted in the water line, normally closed and arranged to be opened by pressure exerted by the act of a person's sitting on the seat;
- a water jet air pump mounted on an end of the water line immediately inside the rim;
- a downwardly extending air intake integral with the pump for exhausting the air space of the toilet bowl;
- a discharge tube integral with the pump, extending downward along the inside of the toilet bowl and terminating under water on the outlet side of the toilet water trap;
- and suction cup means for holding the attachment on the rim.

References Cited in the file of this patent

UNITED STATES PATENTS

1,632,791	Habault	June 21, 1927
1,937,305	Baither	Nov. 28, 1933
2,041,962	Robertson	May 26, 1936