



(12) **EUROPEAN PATENT APPLICATION**

(43) Date of publication:  
**16.03.2005 Bulletin 2005/11**

(51) Int Cl.7: **E03F 5/10, E03F 5/12**

(21) Application number: **04255452.7**

(22) Date of filing: **08.09.2004**

(84) Designated Contracting States:  
**AT BE BG CH CY CZ DE DK EE ES FI FR GB GR  
HU IE IT LI LU MC NL PL PT RO SE SI SK TR**  
Designated Extension States:  
**AL HR LT LV MK**

(72) Inventor: **Ellistone, James Douglas  
Inverness IV3 8PW (GB)**

(74) Representative: **McLean, Robert Andreas et al  
Dummett Copp,  
25 The Square,  
Martlesham Heath  
Ipswich, Suffolk, IP5 3SL (GB)**

(30) Priority: **10.09.2003 GB 0321161**

(71) Applicant: **Vexamus Ltd.  
Wisbech PE13 1NE (GB)**

(54) **Sewage device for filtering excess fluid flows**

(57) A device (1) for filtering excess fluid flows. The device comprises a vessel (2) and the vessel is provided with a floor (6), an inlet (8), a first outlet (10) and a second outlet (12), a solids removal means (28), a partition (14) and flow control means (20). The vessel 2 further includes two overflows (44,46). A first overflow (44) allows fluid to pass from an inlet side (16) to an outlet side (18) of the vessel. The second overflow (46) allows fluid

to pass from the outlet side (18) to the inlet side (16). The two overflows (44,46) are arranged such that, during exceptionally high fluid flows or equipment failure, fluid entering the inlet side (16) may bypass the solids removal means (28) and overflow into the outlet side (18) via the first overflow (44). Fluid in the outlet side (18) of the vessel above a predetermined level overflows to the second outlet (12) via the second overflow (46).

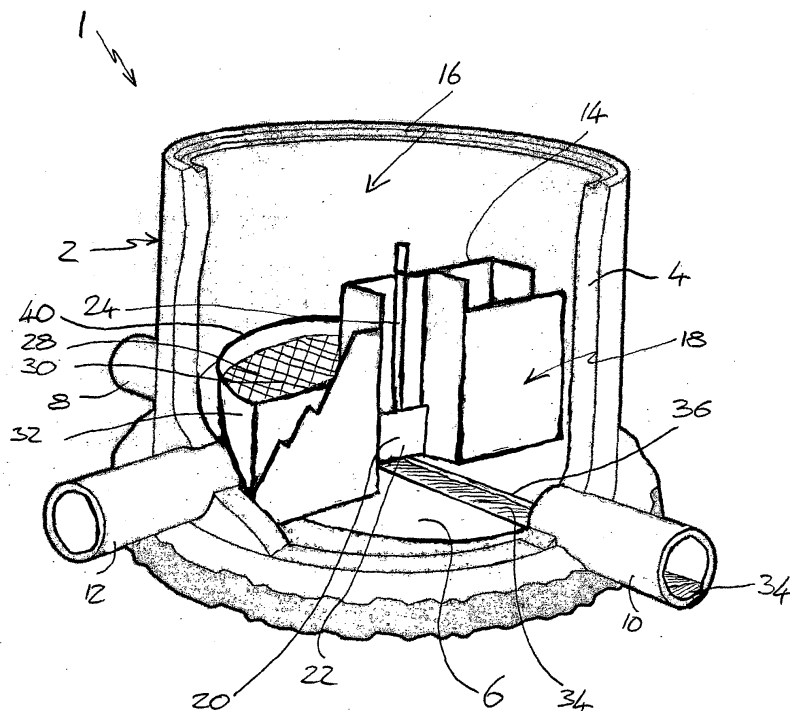

Fig. 1

## Description

**[0001]** The present invention relates to a device for filtering excess liquid flows in a waste fluid system, particularly in a sewer system.

**[0002]** Waste fluid systems such as sewers include pipes to transfer waste fluid between the waste source and a treatment plant. The waste fluids may include entrained, environmentally unfriendly, solid contaminants. In sewer systems particularly there may be times when the fluid flows far exceed the normal flows, for example during a heavy storm, and overflow devices are required to allow the sewer system to cope. Such overflow devices are required to screen out unpleasant solid contaminants before discharge of the otherwise untreated fluid to the environment can occur. This is not expected to occur during normal liquid flows and screens have been developed that include solids removal screens that are substantially self cleaning using a valve to control flow through a normal outlet. However, in the prior devices it has been found that complex control systems or complex device layouts have to be employed in case the valve control fails or the screen blinds and cannot be cleared due to excessive liquid flows. If the screen blinds and is not cleared, it is possible for high pressures to build up within the overflow device which may damage the device or screen.

**[0003]** It is an object of the present invention to provide an overflow device that addresses some of the above problems.

**[0004]** According to the invention there is provided a device for filtering excess fluid flows, the device comprising a vessel, the vessel being provided with a floor, an inlet, a first outlet and a second outlet, a solids removal means, a partition and flow control means, wherein:

- a) the partition divides the vessel into an inlet side including the inlet and the second outlet and an outlet side including the first outlet;
- b) the flow control means is arranged to control fluid flow between the inlet side and the outlet side;
- c) the solids removal means removes solids from fluid flowing from the inlet to the second outlet;
- d) the device further comprises means for accumulating a head of filtered fluid between the filter and the second outlet;

the device is arranged such that:

- 1) under normal fluid flow conditions, waste fluid enters the chamber through the inlet and leaves through the first outlet;
- 2) under expected heavy fluid flow conditions, at least some of the waste fluid entering the inlet side of the vessel is prevented from flowing to the first outlet by the flow control means and is caused to flow through the solids removal means to the sec-

ond outlet, the flow control means is actuatable to allow an increased flow of fluid from the inlet side to the outlet side to allow the head of filtered fluid to backwash through the solids removal means to substantially remove trapped solids; and the device is characterised in that the device further comprises two overflows, a first overflow from the inlet side to the outlet side located at a level above the means for accumulating a head of filtered liquid and a second overflow from the outlet side to the inlet side, the two overflows being arranged such that, during exceptionally high fluid flows or equipment failure, fluid entering the inlet side may bypass the solids removal means and overflow into the outlet side via the first overflow, while fluid in the outlet side of the vessel above a predetermined level overflows to the second outlet via the second overflow.

**[0005]** Such a device provides a single vessel that can be used in line to allow the waste fluid system to cope with increased flows by allowing filtered or screened fluid to flow through the second outlet. The device includes the safety backup of the two overflows that allow fluid entering the vessel to bypass the solids removal means to reach either the first or second outlet. This reduces the likelihood of a potentially dangerous or damaging build up of pressure in the vessel, particularly between the inlet and the solids removal means. In the event of exceptional flows or equipment failure, such as the flow control means failing to actuate to backwash the solids removal means or a blockage in the first outlet, the two overflows allow fluid entering the vessel to bypass the solids removal means and exit through either the first or second outlet. A device according to the invention is particularly applicable to a waste water or sewerage system in which storm water is passed into the sewer resulting in increased waste water flows. It should be noted that the device can be used in offline or online applications.

**[0006]** The inclusion of two overflows in the same vessel allows the device to be installed in a standard sized manhole ring. This means that large custom rings are not required and two or more vessels are not required. This facilitates installation and reduces the cost of installation as standard parts can be used.

**[0007]** The term fluid as used herein is intended to include not only waste liquids such as water, but is also slurries and other mixtures that may flow. This term specifically includes liquids which carry solids, either entrained within the liquid flow, or floating on it as may occur in waste water sewer systems.

**[0008]** Preferably the floor of the vessel directs fluid within the outlet side of the vessel to the first outlet. This may be achieved by having the floor slope downwards towards the first outlet so that fluid flows toward the first outlet under gravity. The floor may also include a channel between the inlet and first outlet such that under normal fluid flow conditions the waste fluid remains substantially within the channel. If such a channel is used

the floor of the outlet side may preferably slope towards the channel. The floor of the inlet side of the vessel preferably directs fluid towards the second outlet.

**[0009]** The partition divides the vessel into an inlet side and an outlet side. It is preferred that the partition does not extend upwards through the entire vessel and preferably extends from the floor to between 0.5 and 0.75 times the height of the vessel as this allows easier access to the interior of the vessel and reduces the material costs for fabricating the partition.

**[0010]** Preferably at least one, and preferably each of the two overflows are weir overflows such that fluid above the level of the weir can overflow from the inlet side to the outlet side or from the outlet side to the inlet side by passing over the weir. Weir overflows are simple to engineer and manufacture, require no moving parts and typically provide little flow restriction to fluid above the weir level. It is preferred that the overflows are located in an upper surface of the partition such that fluid in excess of the height of the weir has substantially no restriction to its flow such as that which may be caused by the overflow being formed as an aperture through the partition.

**[0011]** It is preferred that the flow control means comprises a gate valve arranged such that in a lowered position it substantially prevents fluid from passing through an opening in the partition. An increased fluid flow through the opening can be obtained by raising the gate valve. Raising of the gate valve may cause backwashing of the solids removal means by allowing the head of filtered fluid to flow backwards through the solids removal means thereby substantially removing any trapped solids.

**[0012]** The flow control means may be actuated manually, mechanically or electrically and actuation of the flow control means to cause backwashing of the solids removal means is preferably triggered by a sensing means detecting that the solids removal means is beginning to blind and restrict fluid flow. The sensing means may be a pressure sensor located below the solids removal means that detects a rise in pressure or it may be a level sensor to detect a fluid level in the solids removal means bypass approaching the first overflow.

**[0013]** The inlet and the first outlet are preferably at substantially the same height within the vessel and are preferably substantially opposed such that fluid entering the vessel through the inlet passes across the vessel and to the outlet substantially without deviation as this facilitates fluid flow through the vessel.

**[0014]** The inlet side of the vessel is preferably provided with a screening box into which the inlet feeds the waste fluid. The screening box preferably comprises walls on which the solids removal means is mounted substantially perpendicular to the walls and at a level above the inlet. The walls may extend above the solids removal means to accumulate the head of filtered fluid above said solids removal means by forming a weir. Fluid entering the screening box passes to the outlet side

and to the first outlet. Fluid entering the screening box that is prevented from passing to the first outlet usually passes through the solids removal means, over the walls of the screening box and passes to the second outlet which is preferably located at a level below the height of the means for creating a head of filtered liquid.

**[0015]** It is preferred that the device is arranged such that the fluid flowing into the inlet side from the second overflow is directed away from the filtered or outlet side of the solids removal means. This allows the device to handle the exceptional fluid flows or equipment malfunction without the filtered side of the solids removal means becoming contaminated with unfiltered waste fluid which results in less servicing being required to put the device back into use after the exceptional waste fluid flow has ceased.

**[0016]** The solids removal means is preferably a screen having apertures through which fluid may flow, but that substantially prevents solid material above a predetermined size from passing through. It should be understood that such a screen may be made from any suitable material and may comprise a plurality of layers each comprising apertures of the same or varying size such that the solids removal means serves to prevent solids from passing from the inlet side of the solids removal means to the outlet side of the solids removal means. During a backwash operation the head of filtered fluid passes through the solids removal means and substantially removes solids trapped against the inlet side of the solids removal means.

**[0017]** The invention will now be described, by way of example, with reference to the following figures, in which:

Figure 1 shows a cutaway perspective view of a device in normal operation in a sewer system;

Figure 2 shows a cross section of the device of Figure 1 in normal operation

Figure 3 shows a cross section of the device of Figure 1 in storm operation;

Figure 4 shows a cross section of the device of Figure 1 in backwash operation;

Figure 5 shows a perspective view of the device of Figure 1 in exceptional operation with overflow from an inlet side to an outlet side; and

Figure 6 shows the device of Figure 1 in exceptional operation with overflow from an outlet side to an inlet side.

**[0018]** Figure 1 shows a cutaway perspective view of a device 1 in normal operation in a sewer system (not shown). The device comprises a vessel 2 having walls 4 and a floor 6. The walls 4 of the vessel 2 are substan-

tially cylindrical and the vessel is provided with an inlet 8, a first outlet 10 and a second outlet 12.

[0019] The vessel 2 is further provided with a partition 14 that divides the vessel 2 into an inlet side 16, comprising the inlet 8 and the second outlet 12, and an outlet side 18 comprising the first outlet 10. The partition 14 extends from the floor 6 half way up the walls 4 of the vessel 2. The vessel 2 is also provided with flow control means 20 that are arranged to control the flow of fluid from the inlet 8 to the first outlet 10. The flow control means 20 in this case comprises a gate valve comprising a gate 22 and actuation means 24. The gate 22 substantially closes an opening 26 (not visible in this figure) through the partition 14 and the actuation means 24 is arranged to raise or lower the gate 22 to control the flow of fluid through the opening 26.

[0020] Between the inlet 8 and the second outlet there is provided a solids removal means 28 that comprises a screen 30 that allows fluid to pass through, but substantially prevents the passage of solids. The screen 30 is mounted in a screening box 32 into which the inlet 8 feeds fluid during use. The screening box 32 extends above the screen 30 to create a weir means 40 that collects a head of filtered fluid between the screen 30 and the second outlet 12.

[0021] As shown in Figure 1 the device 1 is in normal operation. Fluid 34 is passing through the inlet 8 and into the screening box 32. The fluid is then passing through the flow control means 20 and to the outlet side 18 and exiting through the first outlet 10. The fluid 34 is contained within a channel 36 in the floor 6 of the outlet side 18. The channel 36 runs along the floor 6 of the outlet side 18 and leads to the first outlet 10. In this mode of operation the device does not filter the fluid 34, but simply allows it to pass from the inlet 8 to the outlet 10.

[0022] Further features of the device 1 will be shown in subsequent figures.

[0023] Figure 2 shows a cross section view of the device 1 of Figure 1 in normal operation as in Figure 1. The fluid 34 enters the screening box 32 through the inlet 8, passes through the flow control means 20 and leaves the device 1 through the first outlet 10.

[0024] Figure 3 shows a cross section view of the device 1 of Figure 1 in storm operation. During storm operation the fluid 34 entering the screening box 32 cannot pass to the outlet side 18 as quickly as it enters the inlet side 16 due to the flow restriction caused by the flow control means 20 being in a down position. Excess fluid 38 in the inlet side flows through the solids removal means 28 and over the weir 40. Fluid that passes over the weir 40 flows out through the second outlet 12 (not shown in this figure). The floor 6 of the inlet side 16 of the vessel is sloped to direct the fluid that passes over the weir 40 to the second outlet 12. Solid material 42 remains trapped on an inlet side of the solids removal means 28. Over time this may cause the solids removal means 28 to blind and substantially prevent the passage of fluid.

[0025] Figure 4 shows a cross section view of the device 1 of Figure 1 in a backwash operation. If the solids removal means 28 begins to blind, as described above, the flow control means 20 may be actuated (in this case raised) to allow an increased fluid flow from the inlet side 16 to the outlet side 18 of the vessel 2. Such an increase in flow to the outlet side 18 usually results in the filtered liquid collected to form the head between the solids removal means 28 and the second outlet 12 backwashing through the solids removal means 28 and substantially removing any trapped solids 42. The flow control means 20 then returns to the down position and the device 1 operates as in Figure 3 until the solids removal means 28 begin to blind again.

[0026] Figure 5 shows the device of Figure 1 during an equipment failure, for example in which the solids removal means 28 has blinded and cannot be cleared.

[0027] Fluid 34 enters the screening box 32 and cannot pass through the flow control means 20 at the rate at which it is entering as in Figure 3. The solids removal means 28 has blinded and cannot be cleared, for example if the flow control means 20 cannot be actuated and a backwash operation cannot be initiated. The excess fluid cannot reach the second outlet 12 by passing through the solids removal means 28 and over the weir 40. The partition 14 includes a bypass passage 42. The bypass passage fluidly connects the screening box 32 with a first overflow 44 that is located above the weir 40. As the fluid pressure in the screening box 32 increases due to the inflow, fluid is caused to rise up the bypass and over the first overflow 44 into the outlet side 18 of the vessel 2. This permits the excess fluid to bypass the solids removal means 28 without causing damage which may otherwise occur. In the situation described above, a higher than normal flow of unfiltered fluid passes through the first outlet 10 which allows another device in a sewer system, of which the device 1 forms part, to deal with the increased fluid flow. This situation should not cause an environmental problem as the first outlet 10 typically has unfiltered fluid passing through it.

[0028] Figure 6 shows the device of Figure 1 during an exceptional situation in which solids removal means has blinded as described in Figure 5 and cannot be cleared, and in which the fluid flowing into the vessel through the inlet 8 cannot leave the vessel 2 through the first outlet 10 at the same rate as it is entering. This may occur, for example, if the first outlet 10 becomes blocked for some reason or, more usually, when the system downstream of the first outlet cannot cope with the increased fluid flow.

[0029] If the first outlet 10 is blocked and the solids removal means 28 blinded the fluid level in the outlet side 18 will rise. The device 1 is provided with a second overflow 46 that allows fluid in the outlet side 18 above the level of the second overflow 46 to overflow into the inlet side and to the second outlet 12. In this exceptional circumstance unfiltered fluid is allowed to flow from the device 1 through the second outlet 12 in order to prevent

damage to the device 1 or sewer system to which it is attached.

[0030] The second overflow 46 is a weir overflow and is at a level approximately the same as the level of the first overflow 44. The second overflow 46 and the screening box 28 are arranged such that the unfiltered fluid passing over the second overflow 46 does not come into contact with the outlet side of the solids removal means 28. This means that less time is required to re-commission the device 1 after such an exceptional event because the outlet side of the solids removal means 28 remains substantially free from solid contaminants.

### Claims

1. A device (1) for filtering excess fluid flows, the device comprising a vessel (2), the vessel being provided with a floor (6), an inlet (8), a first outlet (10) and a second outlet (12), a solids removal means (28), a partition (14) and flow control means (20), wherein:

a) the partition (14) divides the vessel (2) into an inlet side (16) including the inlet (8) and the second outlet (12) and an outlet side (18) including the first outlet (10);

b) the flow control means (20) is arranged to control fluid flow between the inlet side (16) and the outlet side (18);

c) the solids removal means (28) removes solids from fluid flowing from the inlet (8) to the second outlet (12);

d) the device (1) further comprises means (40) for accumulating a head of filtered fluid between the solids removal means (28) and the second outlet (12);

the device is arranged such that:

1) under normal fluid flow conditions, waste fluid enters the vessel (2) through the inlet (8) and leaves through the first outlet (10);

2) under expected heavy fluid flow conditions, at least some of the waste fluid entering the inlet side (16) of the vessel (2) is prevented from flowing to the first outlet (10) by the flow control means (20) and is caused to flow through the solids removal means (28) to the second outlet (12), the flow control means (20) is actuatable to allow an increased flow of fluid from the inlet side (16) to the outlet side (18) to allow the filtered fluid to backwash through the solids removal means (28) to substantially remove trapped solids; and

the device is **characterised in that** the device further comprises two over-

flows, a first overflow (44) from the inlet side (16) to the outlet side (18) located at a level above the means (40) for accumulating a head of filtered liquid and a second overflow (46) from the outlet side (18) to the inlet side (16), the two overflows being arranged such that, during exceptionally high fluid flows or equipment failure, fluid entering the inlet side may bypass the solids removal means and overflow into the outlet side via the first overflow, while fluid in the outlet side of the vessel above a predetermined level overflows to the second outlet via the second overflow.

2. A device as claimed in claim 1, in which the first overflow (44) is a weir overflow.

3. A device as claimed in claim 1 or claim 2, in which the second overflow (46) is a weir overflow.

4. A device as claimed in any preceding claim, in which the solids removal means (28) comprises at least one apertured screen (30).

5. A device as claimed in any preceding claim, in which the inlet side (16) of the device comprises a screening box (32) into which the inlet is to feed fluid, and in which the solids removal means (28) is situated.

6. A device as claimed in any preceding claim, in which the means (40) for accumulating a head of filtered fluid between the filter and the second outlet comprises a weir overflow above the solids removal means (28).

7. A device as claimed in any preceding claim, in which the flow control means (20) is a gate valve (22) that may be raised or lowered to control the flow of fluid from the inlet side to the outlet side.

8. A device as claimed in any preceding claim, in which the partition (14) extends from the floor to between 0.5 and 0.75 times the height of the vessel.

9. A device as claimed in any preceding claim, in which the floor (6) includes a channel (36) between the inlet and the first outlet.

10. A device as claimed in any preceding claim, in which the floor (6) on the outlet side (18) of the vessel is adapted to direct fluid towards the first outlet (10).

11. A device as claimed in any preceding claim, in which the inlet side (16) of the vessel is adapted to direct fluid entering the inlet side from the second

overflow (46) towards the second outlet (12).

12. A device as claimed in any preceding claim, in which fluid entering the inlet side (16) from the second overflow (46) does not contact the solids removal means (28) located between the inlet (8) and the second outlet (12). 5
13. A sewer system comprising a device for filtering excess fluid flows, the device for filtering excess fluid flows being as claimed in any preceding claim. 10

15

20

25

30

35

40

45

50

55

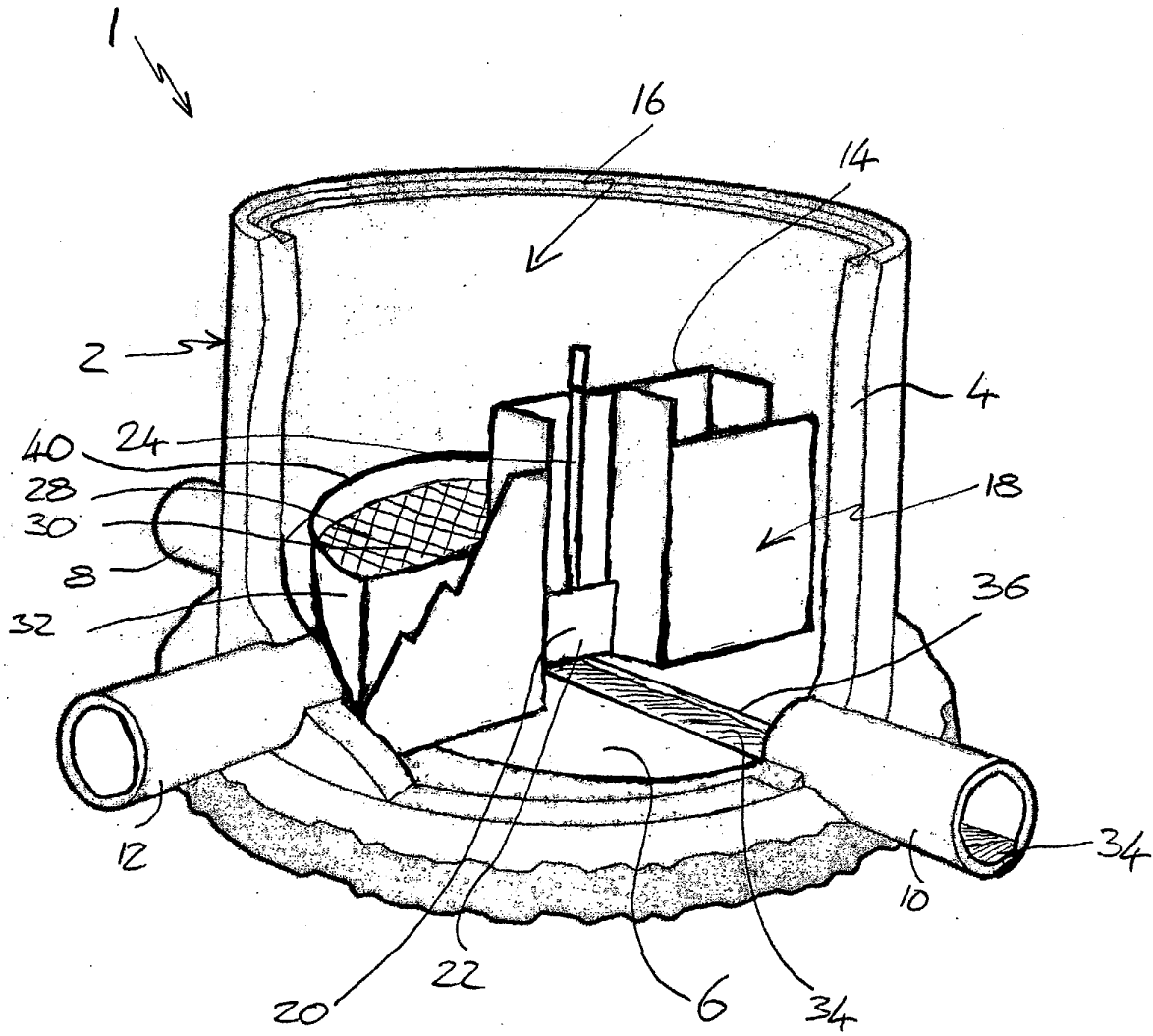

Fig. 1

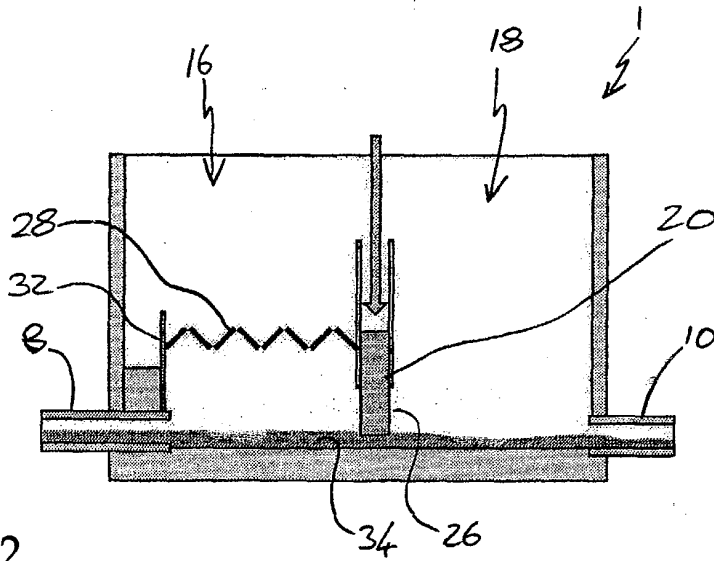

Fig. 2

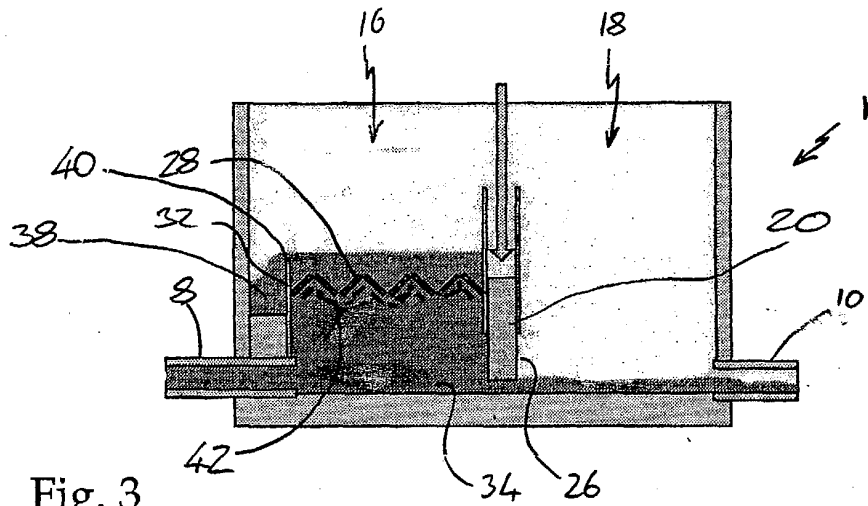

Fig. 3

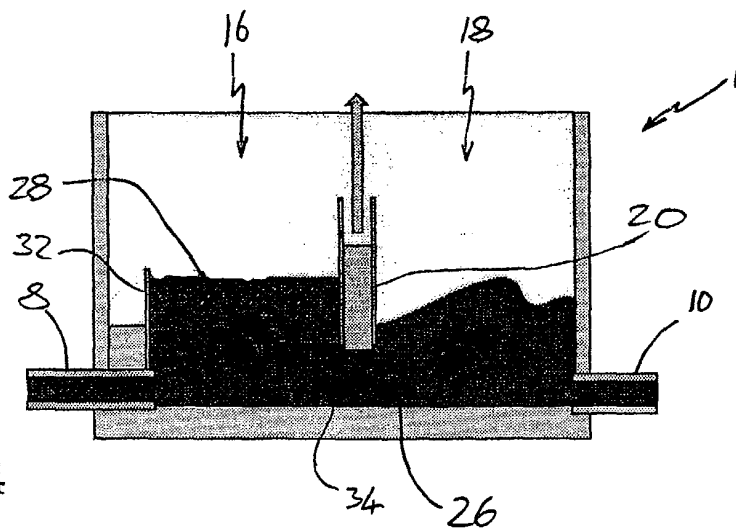

Fig. 4

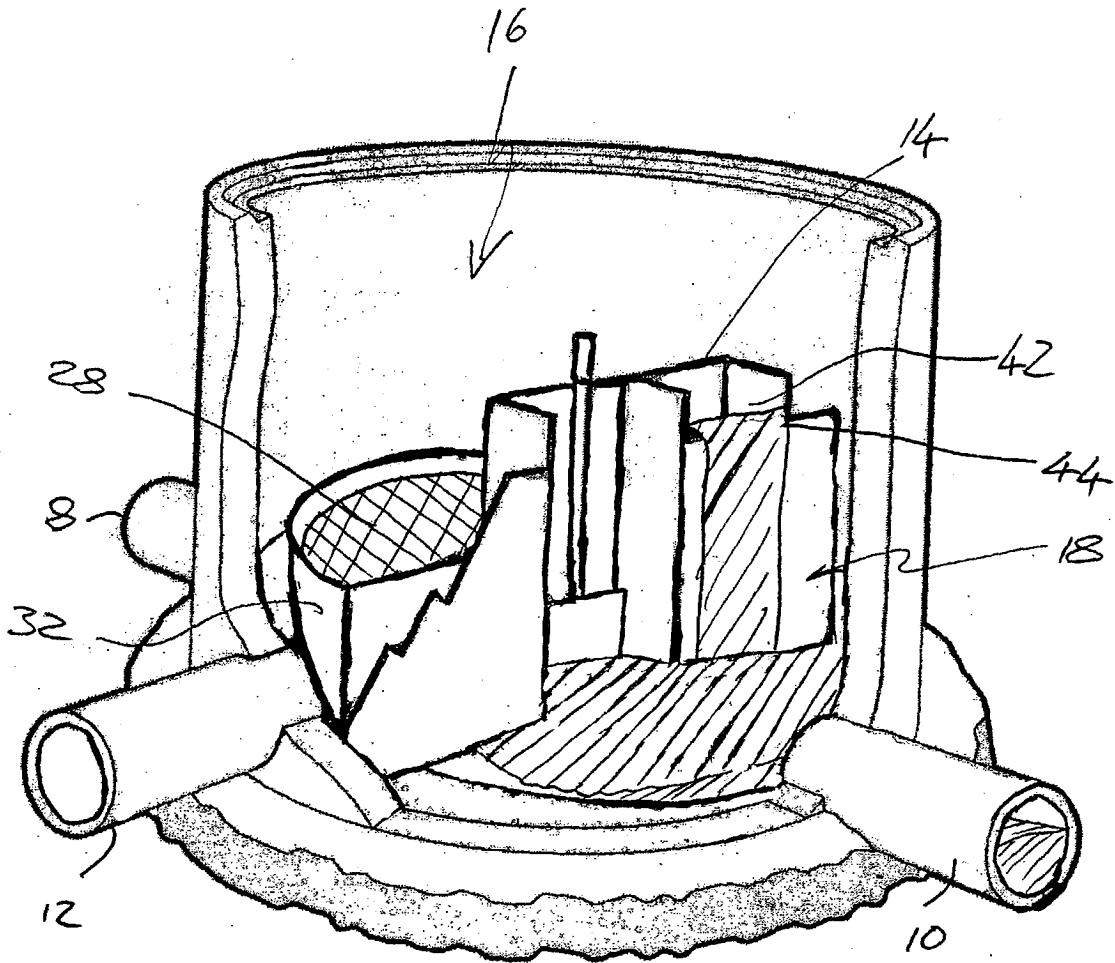

Fig. 5

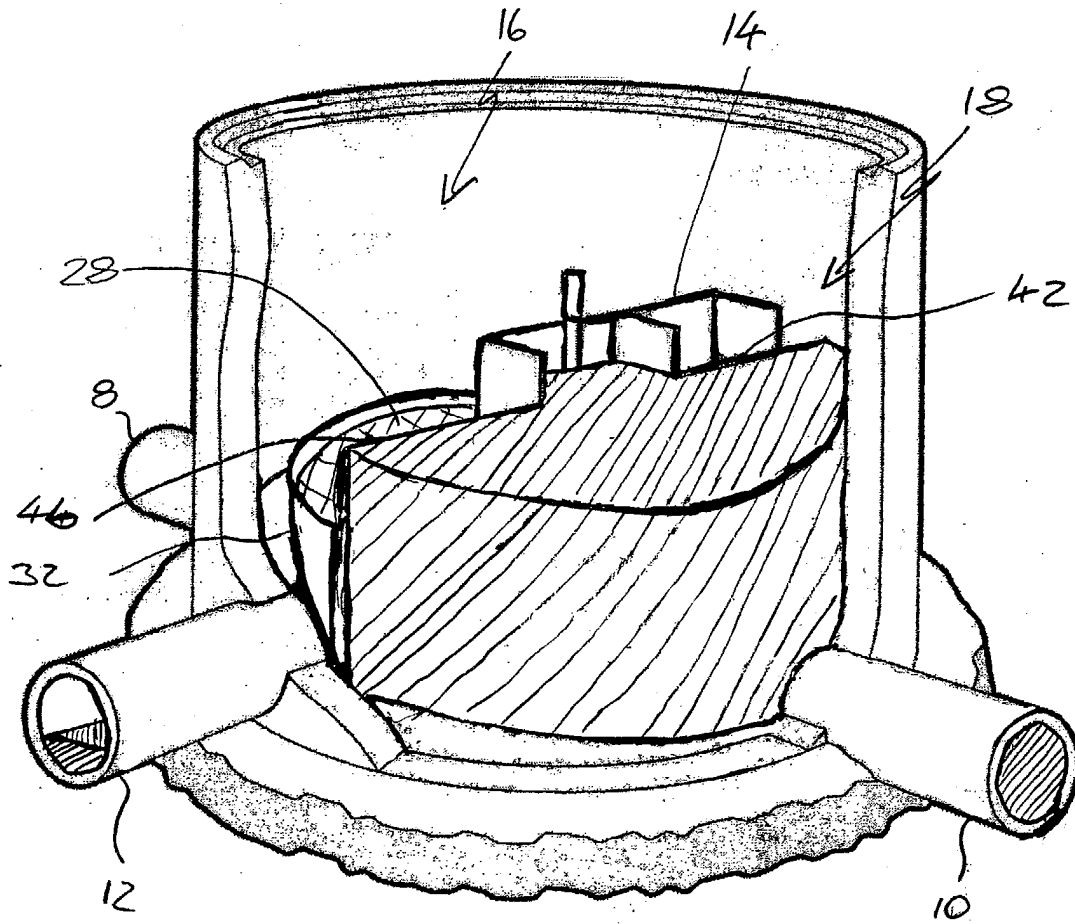

Fig. 6