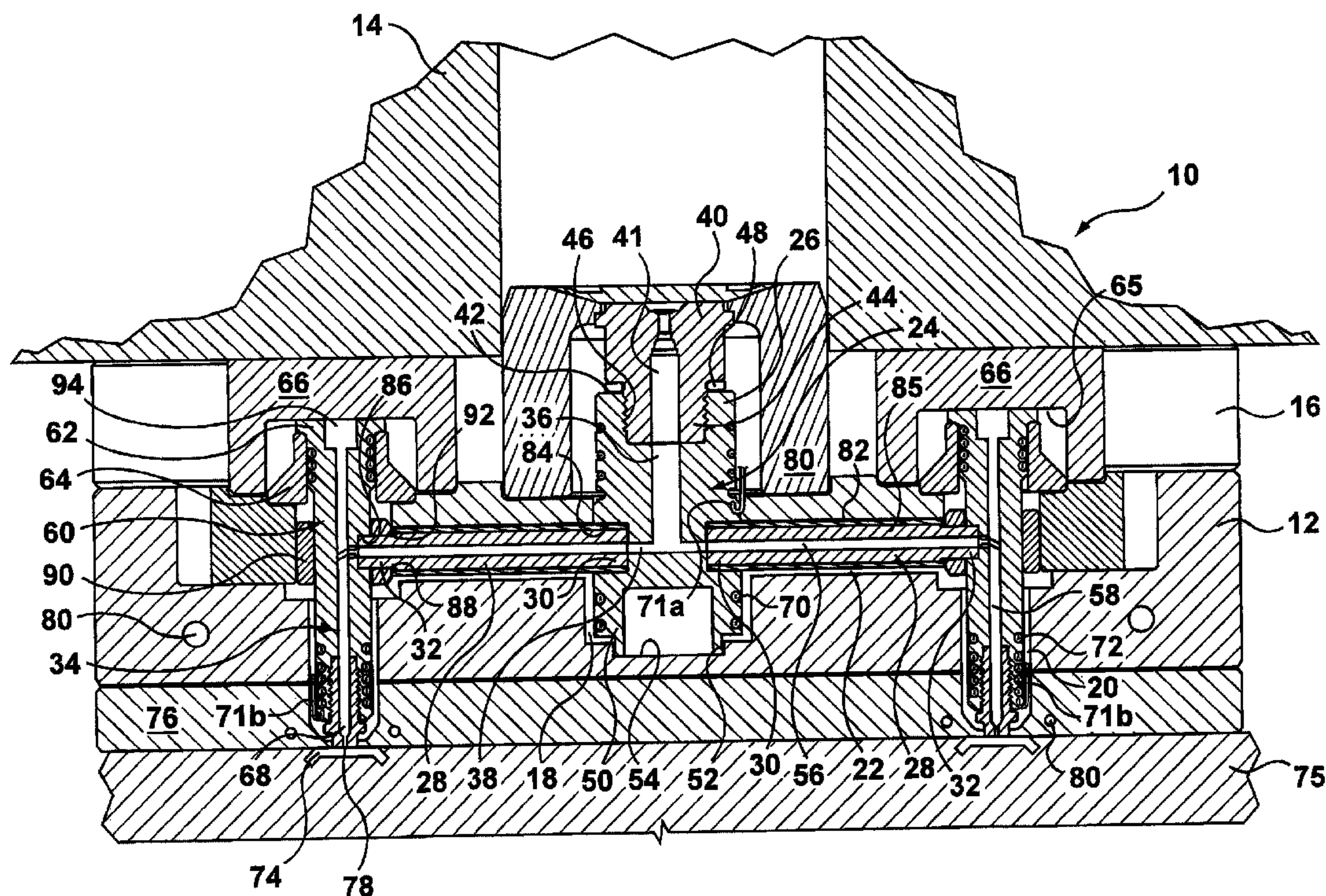




(22) Date de dépôt/Filing Date: 2006/04/07  
(41) Mise à la disp. pub./Open to Public Insp.: 2006/10/07  
(30) Priorité/Priority: 2005/04/07 (US60/668,999)

(51) Cl.Int./Int.Cl. *B29C 45/17* (2006.01),  
*B29C 45/18* (2006.01), *B29C 45/74* (2006.01)  
(71) Demandeur/Applicant:  
MOLD-MASTERS LIMITED, CA  
(72) Inventeurs/Inventors:  
FISCHER, JONATHON, CA;  
FAIRY, FABRICE, CA;  
URSU, DOUGLAS, CA;  
BABIN, DENIS, CA  
(74) Agent: RIDOUT & MAYBEE LLP

(54) Titre : **DISTRIBUTEUR CONFIGURABLE**  
(54) Title: **CONFIGURABLE MANIFOLD**



(57) **Abrégé/Abstract:**

An injection molding apparatus includes a manifold having a heated inlet body and an unheated distribution branch. A melt channel of the inlet body receives a melt stream of moldable material and delivers the melt stream to a melt channel of the distribution branch. The distribution branch has a first end, which is coupled to the inlet body, and a second end, which is coupled to a nozzle. The nozzle includes a nozzle channel for receiving the melt stream from the distribution melt channel. The distribution branch is formed of a tube surrounded by a conductive sleeve. A mold cavity communicates with the nozzle channel and receives the melt stream from the nozzle channel through a mold gate.

**CONFIGURABLE MANIFOLD****ABSTRACT OF THE DISCLOSURE**

An injection molding apparatus includes a manifold having a heated inlet body and an unheated distribution branch. A melt channel of the inlet body receives a melt stream of moldable material and delivers the melt stream to a melt channel of the distribution branch. The distribution branch has a first end, which is coupled to the inlet body, and a second end, which is coupled to a nozzle. The nozzle includes a nozzle channel for receiving the melt stream from the distribution melt channel. The distribution branch is formed of a tube surrounded by a conductive sleeve. A mold cavity communicates with the nozzle channel and receives the melt stream from the nozzle channel through a mold gate.

## CONFIGURABLE MANIFOLD

## FIELD OF THE INVENTION

**[0001]** The present invention relates generally to an injection molding apparatus and, in particular to a configurable manifold for an injection molding apparatus.

## BACKGROUND OF THE INVENTION

**[0002]** In a typical injection molding apparatus, a manifold delivers melt to a mold cavity through a hot runner nozzle. A manifold may include one, two or a plurality of outlets for delivering melt to respective hot runner nozzles. The shape, size and number of mold cavities typically determine the configuration of the manifold and hot runner nozzles for a particular injection molding application. For each different application, the manifold is typically custom made, which is a costly and time-consuming process.

**[0003]** It is therefore desirable to provide a configurable manifold that can be quickly and easily assembled and customized for an injection molding application.

## SUMMARY OF THE INVENTION

**[0004]** According to an embodiment of the present invention there is provided an injection molding hot runner apparatus with a configurable manifold. The configurable manifold includes at least one heated inlet body with a melt channel and at least one distribution branch with a melt channel. The manifold delivers melt from a source to the heated nozzles in a hot runner system. Melt from a source flows through the heated inlet body to the distribution branch where it is then transferred to at least one heated nozzle and delivered to at least one mold cavity. Each distribution branch does not require a heater but instead is surrounded by a thermally conductive layer, which conducts heat from the heated inlet body and the heated nozzle to maintain the temperature

of the melt within a predetermined range as it travels through the distribution branch.

#### BRIEF DESCRIPTION OF THE FIGURES

- [0005] Embodiments of the present invention will now be described more fully with reference to the accompanying drawings in which like reference numerals indicate similar structure.
- [0006] Figure 1 is a side sectional view of an injection molding apparatus according to an embodiment of the present invention.
- [0007] Figure 2 is an isometric view of a manifold plate of Figure 1, prior to customization and assembly.
- [0008] Figures 3 to 10 are schematic top views of various manifold configurations.
- [0009] Figure 10a is a view on 10a-10a of a central body of the 8-drop apparatus of Figure 10.
- [0010] Figure 11 is a side sectional view of an injection molding apparatus according to another embodiment of the present invention.
- [0011] Figure 12 is a side sectional view of an injection molding apparatus according to another embodiment of the present invention.
- [0012] Figure 13 is a side sectional view of an injection molding apparatus according to yet another embodiment of the present invention.
- [0013] Figure 14 is a side sectional view of an injection molding apparatus according to another embodiment of the present invention.
- [0014] Figure 15 is a side sectional view of a distribution branch according to an embodiment of the present invention. Figure 15A is a detail view of the left side of the distribution branch according to Figure 15 showing one alternative way to couple the conductive sleeve to the tube. Figure 15B is a detail view of right side of the distribution branch according to Figure 15 showing an alternative way to couple the conductive sleeve to the tube.

[0015] Figure 16 is a side sectional view of an injection molding apparatus according to another embodiment of the present invention.

[0016] Figure 17 is a side sectional view of an inlet body, distribution branch, and nozzle assembly according to an embodiment of the invention. Figure 17A is a detail view of a first end of the distribution branch coupled to the inlet body.

Figure 18 is a side sectional view of an inlet body, distribution branch, and nozzle assembly according to an embodiment of the invention. Figure 18A is a detail view of a first end of the distribution branch coupled to the inlet body.

#### DETAILED DESCRIPTION OF THE INVENTION

[0017] Referring now to Figure 1, an injection molding apparatus 10 is generally shown. Injection molding apparatus 10 includes a manifold plate 12 that is spaced from a machine platen 14 by pillars 16. Manifold plate 12 includes a central bore 18 and a pair of nozzle receiving bores 20, which are spaced from central bore 18 and located on opposite sides thereof. As shown, the central bore 18 extends part way into the manifold plate 12 and nozzle-receiving bores 20 extend through the manifold plate 12. Troughs 22 extend between the central bore 18 and each of the nozzle receiving bores 20.

[0018] A manifold 24 includes an inlet body 26, which is partially received in central bore 18 of manifold plate 12, and a pair of distribution branches 28, which extend outwardly from the inlet body 26. The distribution branches 28 are received in troughs 22 of the manifold plate 12. Nozzle assemblies 34 are coupled to the distribution branches 28 and are received in the nozzle-receiving bores 20.

[0019] The inlet body 26 includes an inlet channel 36 and a pair of outlet channels 38. A forward end 50 of the inlet body 26 includes a flange 52 that is received in a recess 54 of manifold plate 12. The flange 52 functions to locate

the inlet body 26 with respect to the manifold plate 12. Inlet body 26 is heated by a heater 70 and further includes a thermocouple 71a.

[0020] A sprue bushing 40 having a melt channel 41 is coupled to a rear end 42 of inlet body 26. The sprue bushing 40 includes a threaded projection 44 that is received in a threaded recess 46 of the inlet body 26. A washer 48 is provided between the sprue bushing 40 and the rear end 42 of the inlet body 26. A locating ring 80 surrounds the inlet body 26 and locates the sprue bushing 40 relative to the machine platen 14.

[0021] Each distribution branch 28 includes a first end 30, which is coupled to the inlet body 26, and a second end 32, which is coupled to the nozzle assembly 34. Each distribution branch 28 is generally a tube 85 that is surrounded by a conductive sleeve 82. The conductive sleeve 82 may be copper, aluminum, brass, bronze or any other suitable material that is more conductive than the tube 85 material. The tube 85 is generally made from a type of steel such as H13 or P20. Alternatively, the tube 85 may be made of any other suitable material which can handle the heat and pressure of the melt during the injection molding processes typically up to approximately 350 degrees °C and 50,000 psi. The distribution branch 28 does not include a heater. Instead, heat is transferred to the distribution branch 28 through the conductive sleeve 82 from the inlet body 26 and the nozzle assembly 34. A different conductive device could be substituted for conductive sleeve 82. For example, a conductive coating or film could be applied to tube 85 to transfer heat from inlet body 26 and nozzle assembly 34 to the melt flowing in tube 85.

[0022] First end 30 of distribution branch 28 is slidably received in a bore 84 that is provided in inlet body 26. The bore 84 is sized based on the ranges of operating temperatures in order to accommodate axial thermal expansion of the distribution branch 28 within that operating temperature range. If the bore is too deep, a dead spot may occur between the distribution branch 28 and the inlet body 26, which may trap plastic that will degrade overtime. This degraded material may then be drawn out from the dead spot during subsequent injection cycles and enter the melt stream and consequentially end

up in the molded part. Conversely, if the bore is too shallow, a force may be exerted on the inlet body 26 and the nozzle assembly 34 by the distribution branch 28, which can result in misalignment within the apparatus 10.

[0023] Second end 32 is not surrounded by conductive sleeve 82 and is received in a bore 86 that is provided in the nozzle assembly 34. A clamp 90 surrounds the nozzle assembly 34 and includes a threaded bore 92. A threaded portion 88 of the second end 32 mates with the threaded bore 92 of the clamp 90 to fix the second end 32 of the distribution branch 28 to the nozzle assembly 34. Because the second end 32 is fixed, axial thermal expansion occurs in the direction of the inlet body 26. As such, the alignment of the nozzle assembly 34 with respect to mold cavity 74 is unaffected by the thermal expansion. In addition, radial thermal expansion occurs at the first end 30 due to the conductive sleeve 82, which provides a seal between the distribution branch 28 and the inlet body 26. It will be appreciated by a person skilled in the art the first end 30 of distribution branch 28 may be fixed by any known means to the inlet body 26 while the second end 32 of the distribution branch 28 may be slidably received in bore 86 of the nozzle assembly 34, or that both ends of the distribution branch 28 may be fixed (as shown in Figures 17 and 17A) or sliding (as shown in Figures 18 and 18A).

[0024] Each nozzle assembly 34 includes a nozzle body 60 having a nozzle head 62. A collar 64 surrounds the nozzle body 60 to align the nozzle body 60 relative to the manifold plate 12. The collar 64 is sandwiched between the manifold plate 12 and an abutment surface 65 of a support 66. The collar 64 maintains nozzle head 62 in abutment with the support 66, which is clamped between machine platen 14 and manifold plate 12. Fasteners (not shown) fix the support 66 to the manifold plate 12. A nozzle tip 68 is received in a downstream end of the nozzle body 60 and is threaded thereto. Nozzle channel 58 extends through nozzle body 60 and nozzle tip 68. A plug 94 is received in an upstream end of the nozzle body 60 to seal off a portion of the pre-drilled channel 58. Nozzle assembly 34 is heated by a heater 72 and further includes a thermocouple 71b.

- [0025] Mold cavity 74 is provided between a cavity plate 76 and a mold core 75. The mold cavity 74 receives melt from nozzle channel 58 through a mold gate 78. Cooling channels 80 extend through manifold plate 12 and the cavity plate 76 to cool mold cavity 74.
- [0026] The injection molding apparatus 10 does not include a clamp plate, which is also referred to as a back plate. The clamp plate has been replaced by pillars 16, which space the machine platen 14 from the manifold plate 12. The pillars 16 are located to evenly distribute a clamping force that occurs between the machine platen 14 and the manifold plate 12. This arrangement allows for less material to be used in the apparatus 10, which generally results in lower overall cost.
- [0027] In operation, melt is injected from a machine nozzle (not shown) into inlet channel 36 of inlet body 26 through melt channel 41 of sprue bushing 40. The melt then flows through outlet channels 38 of inlet body 26 into melt channels 56 of distribution branches 28. From the distribution branches 28, the melt flows into nozzle channels 58 of nozzle assemblies 34, through mold gates 78 and into mold cavities 74. During operation, the conductive sleeve 82 transfers heat from the heated inlet body 26 and the heated nozzle assembly 34 to the melt passing through the distribution branch 28 in order to maintain the melt at a desired temperature as it passes between the inlet body 26 to the nozzle assembly 34. Once the mold cavities 74 have been filled with melt, the temperature in the nozzle assembly 34 is lowered to freeze off the plastic at the nozzle tip 68, the melt in the mold cavities 74 is cooled and the molded parts are ejected from injection molding apparatus 10.
- [0028] Referring to Figure 2, a manifold plate 12' is shown prior to final machining and assembly in the injection molding apparatus 10. The manifold plate 12' includes central bore 18 and troughs 22, which are machined therein. Fastener-receiving bores 17 for locating the pillars 16 relative to the manifold plate 12 and fastener-receiving bores 81 for the locating ring 80 are also machined. The partially machined manifold plate 12' may subsequently be



configured for use with various mold cavity dimensions by drilling nozzle receiving bores 20 at desired locations along the troughs 22.

[0029] In order to configure the manifold plate 12' and provide a customized manifold 24, the distance between the nozzle assembly 34 and the inlet body 26 is first determined based on the layout of the mold cavities 74. Once this distance is known, the distribution branches 28 are cut to an appropriate length from either a partially finished stock size or a long tube stock. Partially finished stock sizes tubes have been cut to a length close to the final lengths generally required for distribution branches 28. One end has been finished, for example threaded, while the other end is left unfinished to be trimmed to the final required length. The distribution branches 28 may alternatively be cut from long tube stock to the desired final length and then finished. The conductive sleeves 82 are then cut to length and installed onto the distribution branches 28. Conductive sleeves may be may be installed by shrink fit, hydroforming, brazing, snap-fit as shown in Figure 15A, using a threaded cap as shown in Figure 15B, or any other method known in the art. Nozzle-receiving bores 20 are drilled at proper locations along the troughs 22. The inlet body 26, distribution branches 28 and nozzle assemblies 34 are then assembled to form the manifold 24, which is dropped into the manifold plate 12. By maintaining partially machined manifold plates 12', standard length distribution branches 28, and standard nozzle assemblies 34 in stock, the length of time between receiving a custom order for a manifold for an injection molding apparatus and delivering the manifold is minimized.

[0030] Manifold plate 12' may be configured to provide a single drop apparatus, which includes one nozzle assembly delivering melt to one mold cavity, as shown in Figure 3, or a two-drop apparatus, such as the apparatuses shown in Figures 4 and 5. Stock manifold plates having alternate layouts may also be provided and may be configured to provide the two, three and four drop apparatuses shown in Figures 6 to 9. Figures 5 and 7 show examples of injection molding apparatuses in which the distribution branches 28 have been

cut to various lengths to locate the nozzle assemblies 34 at different distances from the inlet body 26 to provide customized hot runner molds.

[0031] Figure 10 shows a manifold 24a of an eight drop injection molding apparatus. A manifold plate (not shown) is configured to receive manifold 24a, as has been described previously. Manifold 24a includes a pair of primary distribution branches 128 that extend between an inlet body 26a and a pair of central bodies 106. Central bodies 106 are similar in function to inlet body 26a with the exception that they receive melt from distribution branches 128 rather than from the machine through the sprue bushing 40. Secondary distribution branches 228 extend between each central body 106 and a respective nozzle assembly 34a. Central body 106, which is shown in Figure 10a, includes an inlet channel 108 for receiving melt from a melt channel 156 of primary distribution branch 128 and four outlet channels 110 for delivering melt to melt channels 256 of secondary distribution branches 228. Operation of the eight drop apparatus is similar to operation of the injection molding apparatus of Figure 1 and therefore will not be described further here.

[0032] Referring to Figure 11, another embodiment of an injection molding apparatus 10b is shown. Injection molding apparatus 10b is similar to injection molding apparatus 10 of Figure 1, however, distribution branches 28b have been cut to an appropriate length from a stock size and then machined to provide a projection 112 and a shoulder 114 at first end 30b thereof. The projection 112 allows for sealing between the distribution branches 28b and inlet 26b over a larger window of heat expansion which as a result allows the injection molding apparatus 10b to be operational within a wider operating temperature window. A thermocouple 71c is inserted into tube 85b to monitor the temperature of tube 85b, however in a further embodiment the thermocouple 71c can also feedback to a controller to adjust the temperature of the tube 85b by adjusting the heater 70 in the inlet body 26b and/or the heater 72 in the nozzle assembly 34.

[0033] First end 30b of distribution branch 28b is slidably received in bore 83, which is provided in inlet body 26b, and projection 112 is received in outlet

channel 38b of inlet body 26b. A tapered inner wall 116 provides a smooth transition for the melt to flow between the inlet body 26b and the distribution branch 28b. Bore 83 is sized to allow for axial thermal expansion of conductive sleeve 82b of the distribution branch 28b up to a maximum operating temperature. A seal is provided between distribution branch 28b and the inlet body 26b by the projection 112, which includes a diameter that is sized to fit within the outlet channel 38b. When the distribution branch 28b is operated at a temperature that is less than the maximum operating temperature, a gap 118 occurs between an end surface 115 of bore 83 and the shoulder 114 of the distribution branch 28b. The gap 118 generally does not collect melt during operation of the injection molding apparatus 10b as a result of the seal provided between the projection 112 and the outlet channel 38b. This seal is maintained regardless of the operating temperature because the tube 85b of distribution branch 28b and the inlet body 26b are typically made of the same material, therefore no relative thermal expansion occurs. Because the seal is provided between the projection 112 and the outlet channel 38b, the tolerance on the length of the distribution branch 28b and the tolerance on the depth of bore 84 may both be slightly relaxed.

[0034] Inlet body 26b of injection molding apparatus 10b further includes a flange 52b that is received in recess 54b of manifold plate 12b to locate the inlet body 26b with respect to the manifold plate 12b. The flange 52b is made of a material that is more insulative than the material from which inlet body 26b is made in order to provide a thermal barrier between the inlet body 26b and the manifold plate 12b. The flange 52b is coupled to the inlet body 26b by brazing or any other suitable method and the flange 52b may be made of any suitable insulative material such as, titanium or ceramic, for example.

[0035] Referring to Figure 12, another embodiment of an injection molding apparatus 10c including configurable manifold 24c is shown. Injection molding apparatus 10c includes a manifold plate 12c having a central bore 18c and a trough 22c for receiving an inlet body 26c and a distribution branch 28c of manifold 24c. The manifold plate 12c further includes a nozzle-receiving

bore 20c for receiving a nozzle assembly 34c. Inlet body 26c includes an inlet channel 36c for receiving a melt stream from a machine nozzle (not shown) and an outlet channel 38c. A melt channel 56c of the distribution branch 28c receives melt from outlet channel 38c and delivers the melt to a nozzle channel 58c of nozzle assembly 34c. Inlet body 26c includes heater 70c, which is coupled to a power source (not shown) through a connector 102.

**[0036]** A valve pin 96, which is movable by an actuator 98, is slidable through nozzle channel 58c of nozzle body 60c to selectively open a mold gate 78c. A valve pin bushing 104 is provided in an upstream end of nozzle body 60c. The actuator 98 is housed in support 66c, which is sandwiched between machine platen 14c and nozzle flange 67. Nozzle flange 67 supports the nozzle body 60c and is located between the manifold plate 12c and the support 66c. The actuator 98 includes a cap 101. The support 66c is coupled to manifold plate 12c by a fastener 100 extending from cap 101, through support 66c, through nozzle flange 67, and into manifold plate 12c. The nozzle flange 67 and support 66c may be made of a material which is less thermally conductive than the nozzle body 60c material to limit thermal conduction therebetween. In addition a layer (not shown) of material more insulative than the nozzle body 60c can be provided between nozzle body 60c, nozzle flange 67, and support 66c to also limit thermal conduction therebetween.

**[0037]** Distribution branch 28c is generally a tube 85c that is surrounded by a conductive sleeve 82c. The distribution branch 28c does not include a heater. Similar to the embodiment of Figure 1, heat is transferred to the distribution branch 28c through the conductive sleeve 82c from the inlet body 26c and the nozzle assembly 34c. The distribution branch 28c includes a first end 30c, which is coupled to the inlet body 26c, and a second end 32c, which is coupled to nozzle assembly 34c. First end 30c is slidably received in a bore 84c provided in inlet body 26c. The bore 84c is sized to allow for axial thermal expansion of the distribution branch 28c. Second end 32c is not surrounded by conductive sleeve 82c and is threaded. The second end 32c is received in a threaded bore 86c that is provided in nozzle body 60c of the nozzle assembly

34c. Because the second end 32c is fixed, axial thermal expansion occurs in the direction of the inlet body 26c. As such, the alignment of the nozzle assembly 34c with respect to a mold cavity 74c is unaffected by the thermal expansion. In addition, radial thermal expansion occurs at the first end 30c due to the conductive sleeve 82c, which provides a seal between the distribution branch 28c and the inlet body 26c.

**[0038]** It will be appreciated by a person skilled in the art that the second end 32c of the distribution branch 28c may alternatively be fixed to the nozzle body 60c by brazing or any other suitable method.

**[0039]** In operation, melt is injected from a machine nozzle (not shown) into inlet channel 36c of inlet body 26c through melt channel of sprue bushing (not shown). The melt then flows through outlet channels 38c of inlet body 26c into melt channels 56c of distribution branches 28c. From the distribution branches 28c, the melt flows into nozzle channel 58c of nozzle assembly 34c, through mold gate 78c and into mold cavity 74c. During operation, the conductive sleeve 82c transfers heat from the heated inlet body 26c and the heated nozzle assembly 34c to the melt passing through the distribution branch 28c in order to maintain the melt at a desired temperature as it passes between the inlet body 26c to the nozzle assembly 34c. Once the mold cavity 74c has been filled with melt, the valve pin 96 is actuated to a forward position to close off the gate 78c in the nozzle tip 68c to prevent the melt from continuing to flow into the mold cavity 74c, the melt in the mold cavity 74c is cooled and the molded parts are ejected from injection molding apparatus 10c.

**[0040]** Referring to Figure 13, an injection molding apparatus 10d according to another embodiment is shown. The injection molding apparatus 10d is similar to the embodiment of Figure 11, however, both first end 30d and second end 32d of distribution branch 28d are slidable within bores 84d and 86d of inlet body 26d and nozzle assembly 34d, respectively. Distribution branch 28d is generally a tube 85d that is surrounded by a conductive sleeve 82d and is unheated. Heat is transferred to the distribution branch 28d via the conductive sleeve 82d from the inlet body 26d and the nozzle assembly 34d.

When the injection molding apparatus 10d is heated to an operating temperature, the distribution branch 28d is free to expand axially in both directions. In addition, the distribution branch 28d expands radially so that first end 30d and second end 32d form a seal between the inlet body 26d and nozzle body 60d, respectively.

[0041] Referring now to Figure 14, an injection molding apparatus 10e is generally shown. Injection molding apparatus 10e is generally similar to injection molding apparatus 10 of Figure 1, except that it does not include pillars 16. Instead manifold plate 12e extends to clamp plate 13e. In other respects, Figure 14 is similar to Figure 1, therefore, all of the parts will not be described again herein.

[0042] Referring to Figure 15, an exemplary distribution branch 28 is shown with alternative means to couple conductive sleeve 82 to tube 85. Figure 15A shows a snapfit arrangement, wherein a protrusion 110 in sleeve 82 is pressed into a depression 112 in tube 85. Figure 15B shows an arrangement wherein a threaded cap 114 is coupled to sleeve 82.

[0043] Referring to Figure 16, an alternative embodiment of an injection molding apparatus 10f including configurable manifold 24f is shown. Injection molding apparatus 10f includes a manifold plate 12f having a central bore 18f and a trough 22f for receiving an inlet body 26f and a distribution branch 28f of manifold 24f. The manifold plate 12f further includes a nozzle-receiving bores 20f for receiving nozzle assemblies 34f. Inlet body 26f includes an inlet channel 36f for receiving a melt stream from a machine nozzle (not shown), and outlet channels 38f. A melt channel 56f of each distribution branch 28f receives melt from a respective outlet channel 38f and delivers the melt to a nozzle channel 58f of nozzle assembly 34f. As in Figure 14, manifold plate 12f abuts clamp plate 13f such that the pillars described with respect to Figure 1 are not used. Figure 16 illustrates a more conventional valve pin arrangement, with valve pin 96f movable by an actuator 98f. Actuator 98f is separate from nozzle body 60f. Other features of

actuator 98f are generally conventional and are known to those of ordinary skill in the art.

**[0044]** Figures 17, 17A, 18, and 18A show alternative arrangements for coupling distribution branch 28 to nozzle assembly 34. Figures 17, 17A, 18, and 18A are shown in the heated configuration as conductive sleeve 82 abuts against inlet body 26 on one end and clamp 90 at another end. Figures 17 and 17A show first end 30 and second end 32 fixedly coupled to inlet body 26 and nozzle assembly 34, respectively. First end 30 is threaded and is coupled to threaded recess 84 of inlet body 26. Second end 32 includes a threaded portion 88 and is coupled to threaded bore 92 of clamp 90. Figures 18 and 18A show distribution branch 28 slidably coupled at first end 30 and second end 32 to inlet body 26 and nozzle assembly 34, respectively. In particular, first end 30 is received in recess 84 of inlet body 26. In the heated condition shown in Figures 18 and 18A, first end 30 abuts against a wall of recess 84. Similarly, second end 32 is slidably received in a bore 92 of clamp 90 and a recess of nozzle body 60.

**[0045]** The many features and advantages of the invention are apparent from the detailed specification and, thus, it is intended by the appended claims to cover all such features and advantages of the invention that fall within the true spirit and scope of the invention. Further, since numerous modifications and changes will readily occur to those skilled in the art, it is not desired to limit the invention to the exact construction and operation illustrated and described, and accordingly all suitable modifications and equivalents may be resorted to, falling within the scope of the invention.

## WHAT IS CLAIMED IS:

1. An injection molding apparatus comprising:
  - a manifold including a heated inlet body having a first melt channel and a distribution branch having a second melt channel, said first melt channel for receiving a melt stream of moldable material from a source and delivering said melt stream to said second melt channel, said distribution branch having a first end coupled to said inlet body, said first end being slidable relative to said inlet body;
  - a nozzle coupled to a second end of said distribution branch, said nozzle having a nozzle channel for receiving said melt stream from said second melt channel, said second end of said distribution branch being fixed relative to said nozzle;
  - a mold cavity in communication with said nozzle channel, said mold cavity for receiving said melt stream from said nozzle channel through a mold gate;
  - wherein said distribution branch is unheated.
2. The injection molding apparatus as claimed in claim 1, wherein said distribution branch is generally a tube surrounded by a sleeve.
3. The injection molding apparatus as claimed in claim 2, wherein said sleeve is made of a material that is more thermally conductive than a material from which said tube is made.
4. The injection molding apparatus as claimed in claim 2 or 3, wherein said sleeve is made of a material selected from the group consisting of: copper, aluminum, brass and bronze.
5. The injection molding apparatus as claimed in any one of claims 1-4, wherein said second end of said distribution branch is threaded to said nozzle.



6. The injection molding apparatus as claimed in any one of claims 1-4, wherein said second end of said distribution branch is coupled to said nozzle by a clamp, said clamp surrounding said nozzle.
7. The injection molding apparatus as claimed in claim 6, wherein said second end of said distribution branch is threaded to said clamp.
8. The injection molding apparatus as claimed in claim 3, wherein said first end of said distribution branch includes a projection received in said first melt channel of said inlet body.
9. A manifold for an injection molding apparatus, said manifold comprising:
  - a heated inlet body having an inlet channel and an outlet channel, said inlet channel for receiving a melt stream of moldable material from a source;
  - a distribution branch having a first end and a second end, said first end being coupled to said inlet body, said distribution branch being unheated;
  - a melt channel extending through said distribution branch, said melt channel for receiving melt from said outlet channel of said heated inlet body;
  - wherein said distribution branch includes a tube made of a first material surrounded by a second material that is more conductive than said first material.
10. The manifold as claimed in claim 9, wherein said second material is a conductive sleeve and is selected from the group consisting of: copper, aluminum, brass and bronze.
11. The manifold as claimed in claim 9 or 10, wherein said tube is made of steel.

12. The manifold as claimed in any one of claims 9-11, wherein said second end of said distribution branch is coupled to a nozzle.
13. The manifold as claimed in claim 12, wherein said second end of said distribution branch is slidable relative to said nozzle and said first end is fixed relative to said inlet body.
14. The manifold as claimed in claim 12, wherein said second end of said distribution branch is fixed relative to said nozzle and said first end is fixed relative to said inlet body.
15. The manifold as claimed in any one of claims 9-11, wherein said first end of said distribution branch is slidable relative to said inlet body and said second end is slidable relative to said nozzle.
16. The manifold as claimed in any one of claims 9-11, wherein said first end of said distribution branch is fixed relative to said inlet body and said second end is fixed to said nozzle.
17. The manifold as claimed in claim 9, wherein said second material is a coating.
18. The manifold as claimed in claim 9, wherein said second material is a film.
19. An injection molding apparatus comprising:  
a manifold having a manifold channel, said manifold channel receiving a melt stream of moldable material from a source, said manifold including a heated inlet body and a passively heated distribution branch, said inlet body having a melt channel and receiving a stream of moldable material from a source and delivering said melt stream to a melt channel in said distribution

- 17 -

branch, said distribution branch having a first end coupled to said inlet body, said first end being slidable relative to said inlet body;

said manifold being spaced from a machine platen by a plurality of pillars;

said distribution branch having a second end coupled to a nozzle assembly, said nozzle assembly having a nozzle channel for receiving said melt stream from said manifold channel;

a mold cavity in communication with said nozzle channel of said nozzle assembly for receiving said melt stream through a mold gate;

wherein said plurality of pillars are located to evenly distribute a clamping force between said machine platen and said manifold.

20. A method of producing a manifold comprising:

providing an inlet body having an inlet channel and an outlet channel;

providing a distribution branch having a first end, a second end and a melt channel extending therethrough;

trimming said first end of said distribution branch to provide a distribution branch having a desired length;

coupling said first end of said distribution branch to said inlet body to allow said melt channel of said distribution branch to communicate with said outlet channel of said inlet body;

coupling said second end of said distribution branch to a nozzle assembly;

wherein said distribution branch is unheated and includes tube made of a first material surrounded by a second material that is more conductive than said first material.

21. The method as claimed in claim 20, wherein said second material is a sleeve.

- 18 -

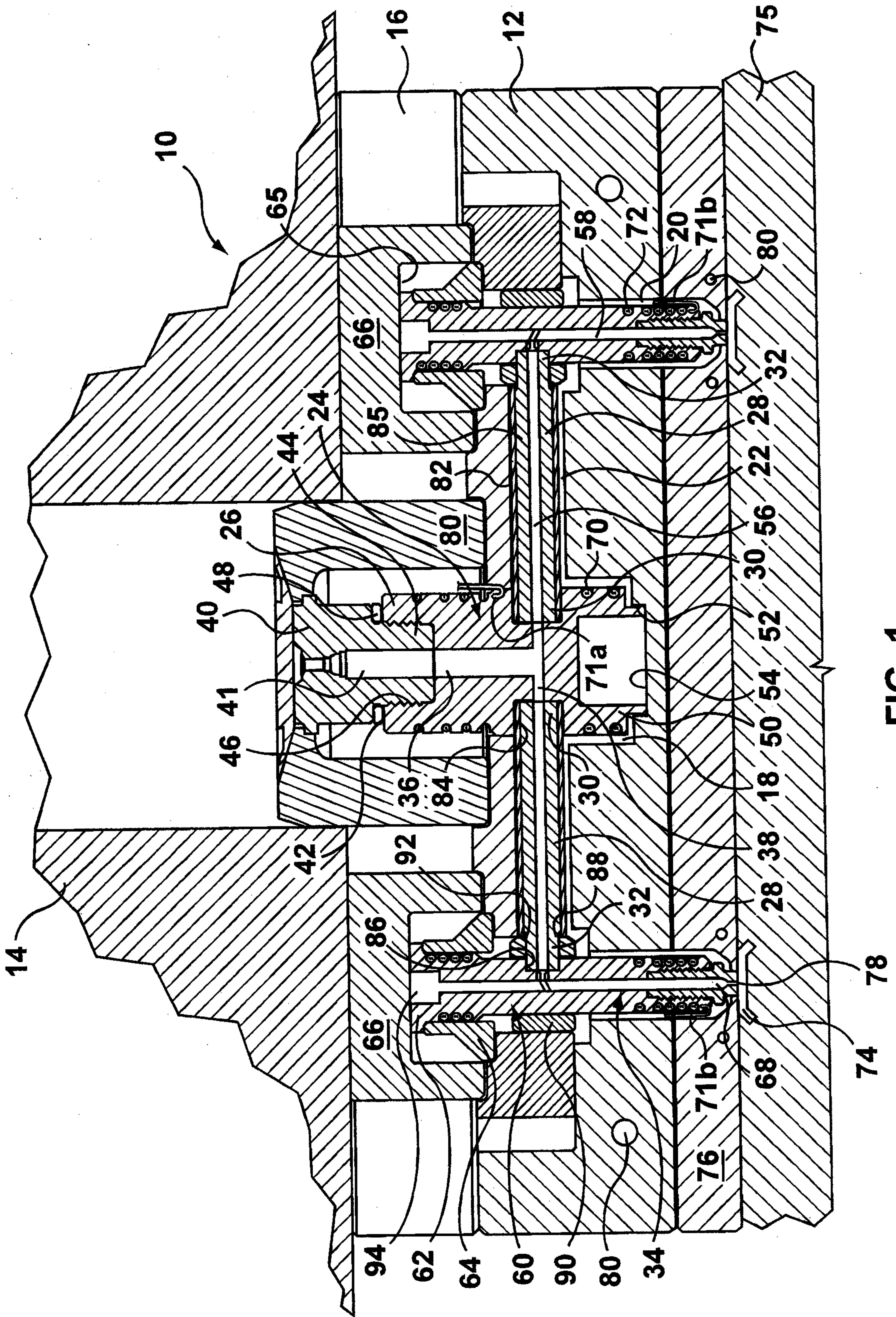
22. The method as claimed in claim 21, wherein said sleeve is made of a material selected from the group consisting of: copper, aluminum, brass and bronze.

23. The method of claim 20, wherein said second material is a coating.

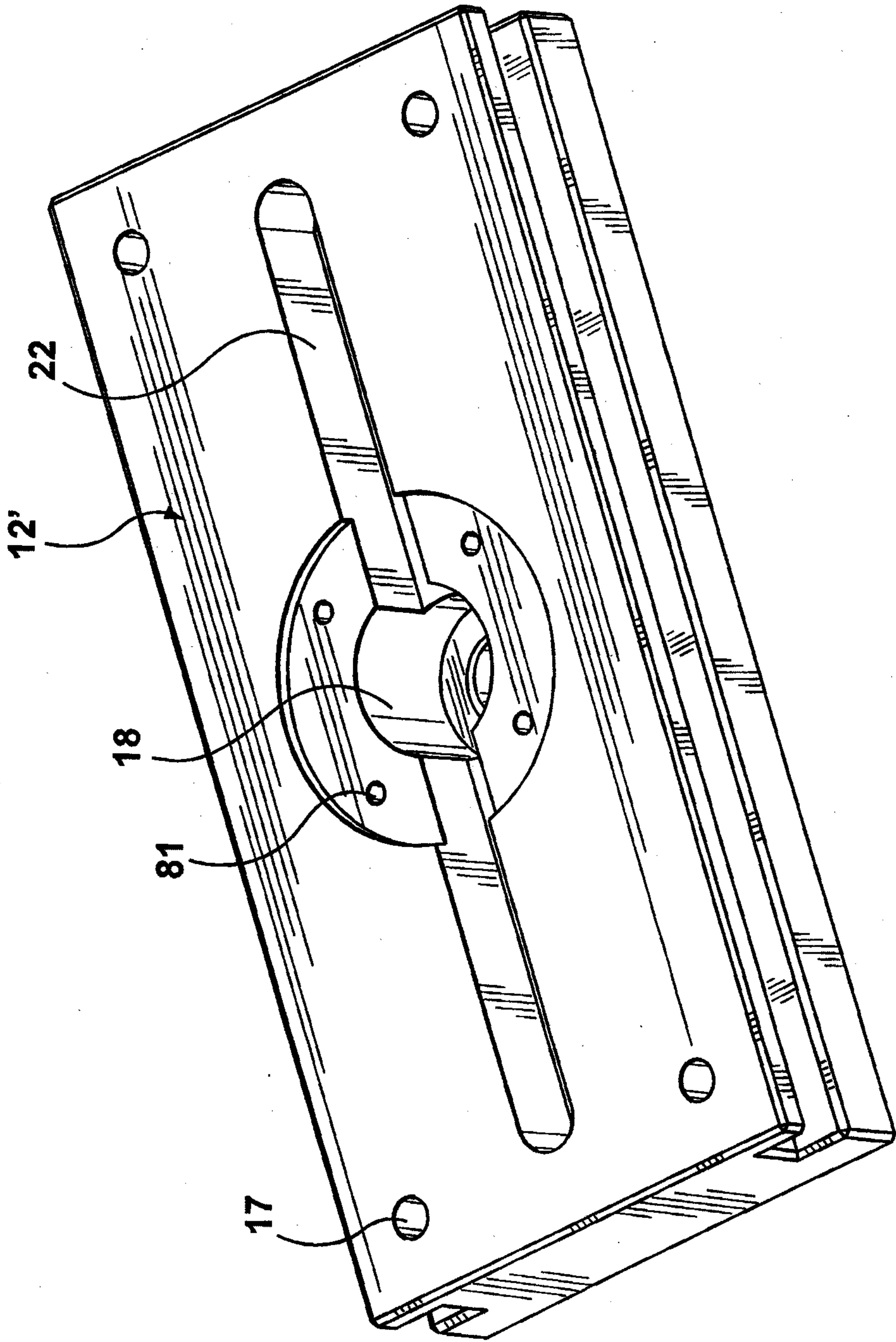
24. The method of claim 20, wherein said second material is a film.

25. The method of claim 20, wherein said first end of said distribution branch is coupled to said inlet body by inserting said first end into a bore provided in said inlet body and said second end of said distribution branch is coupled to said nozzle assembly so that axial movement relative to said nozzle assembly is restricted.

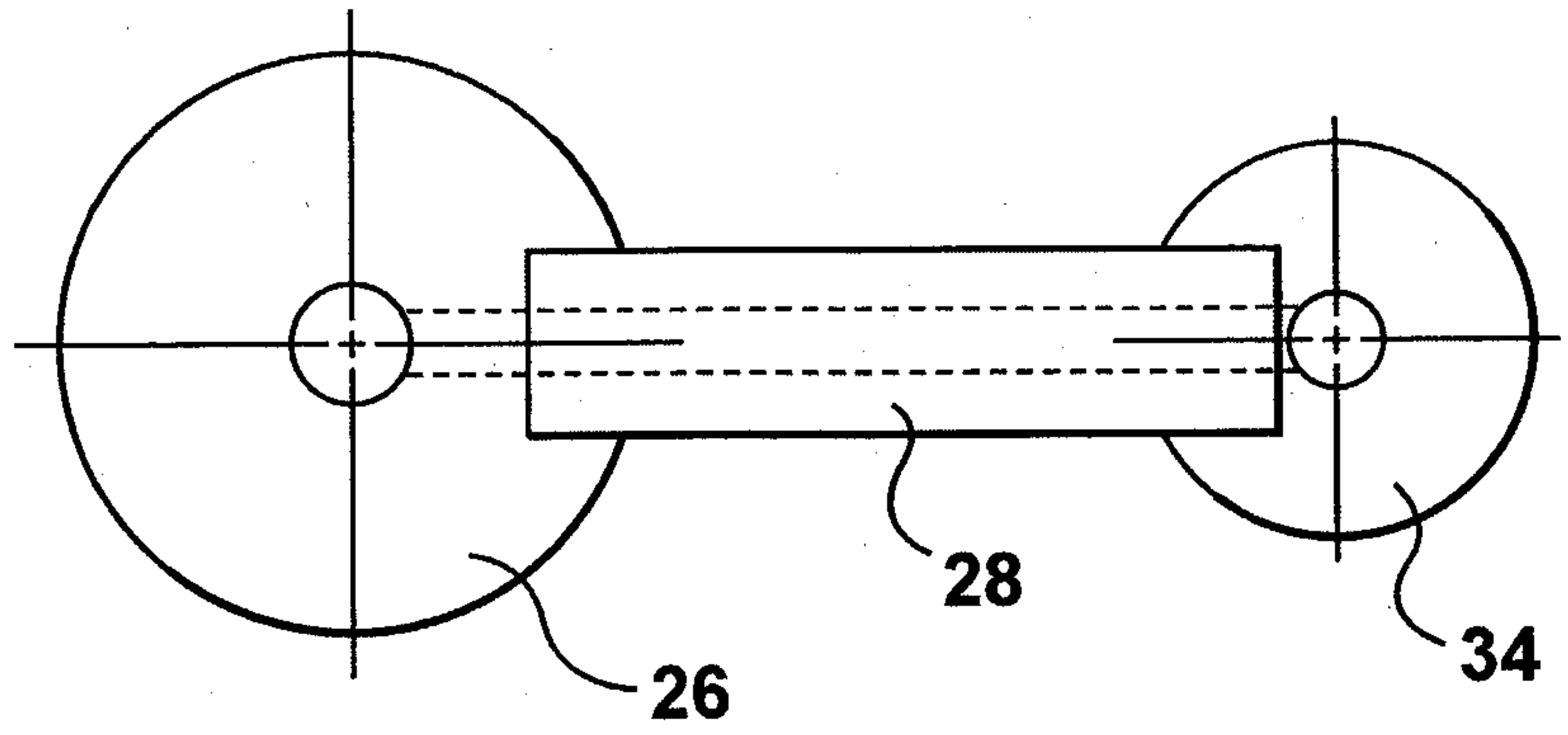
**Ridout & Maybee LLP  
Suite 2400  
One Queen Street East  
Toronto, Canada M5C 3B1  
Patent Agents of the Applicant**



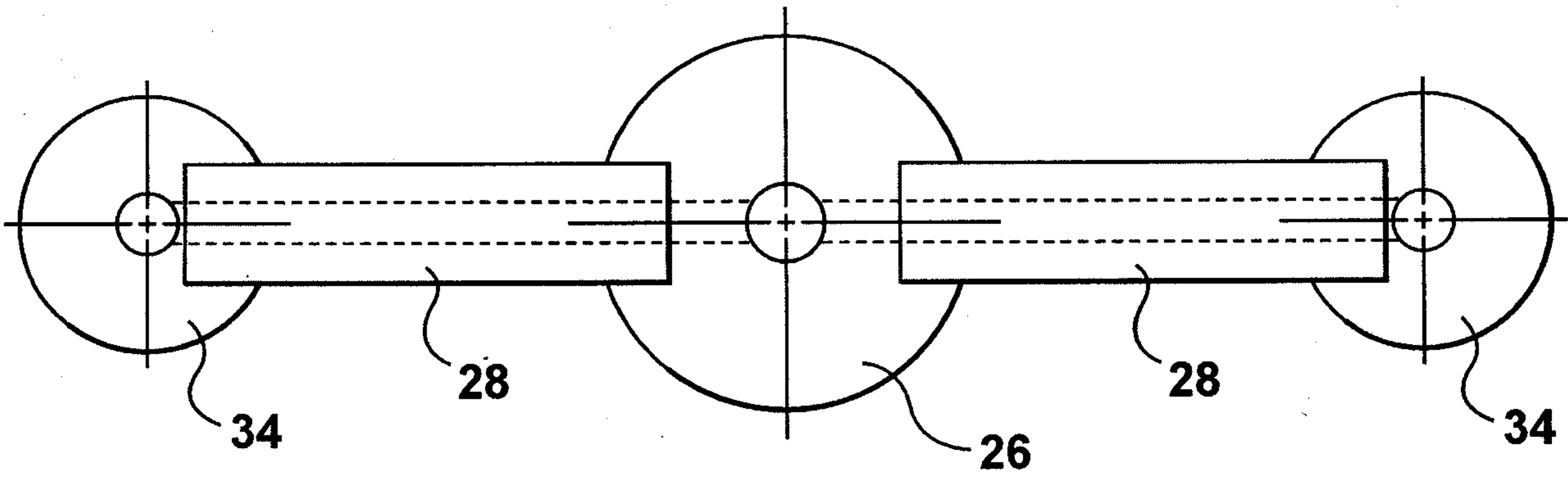
**FIG. 1**



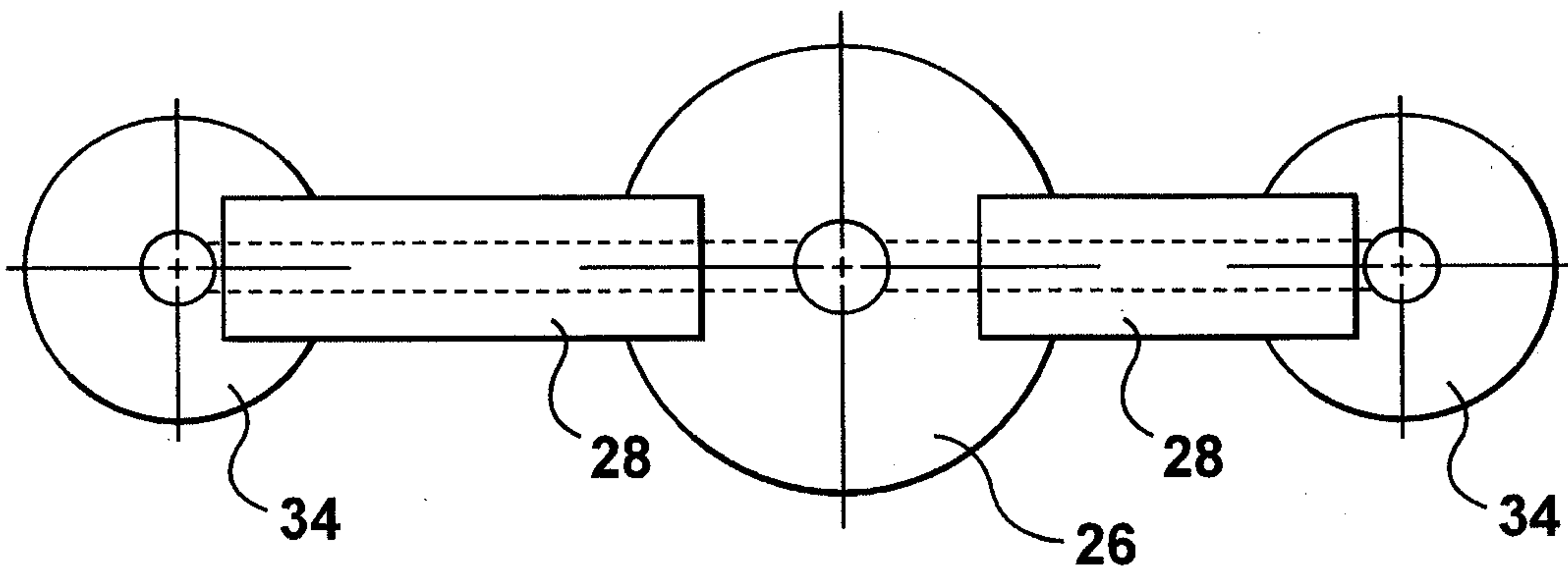
**FIG. 2**



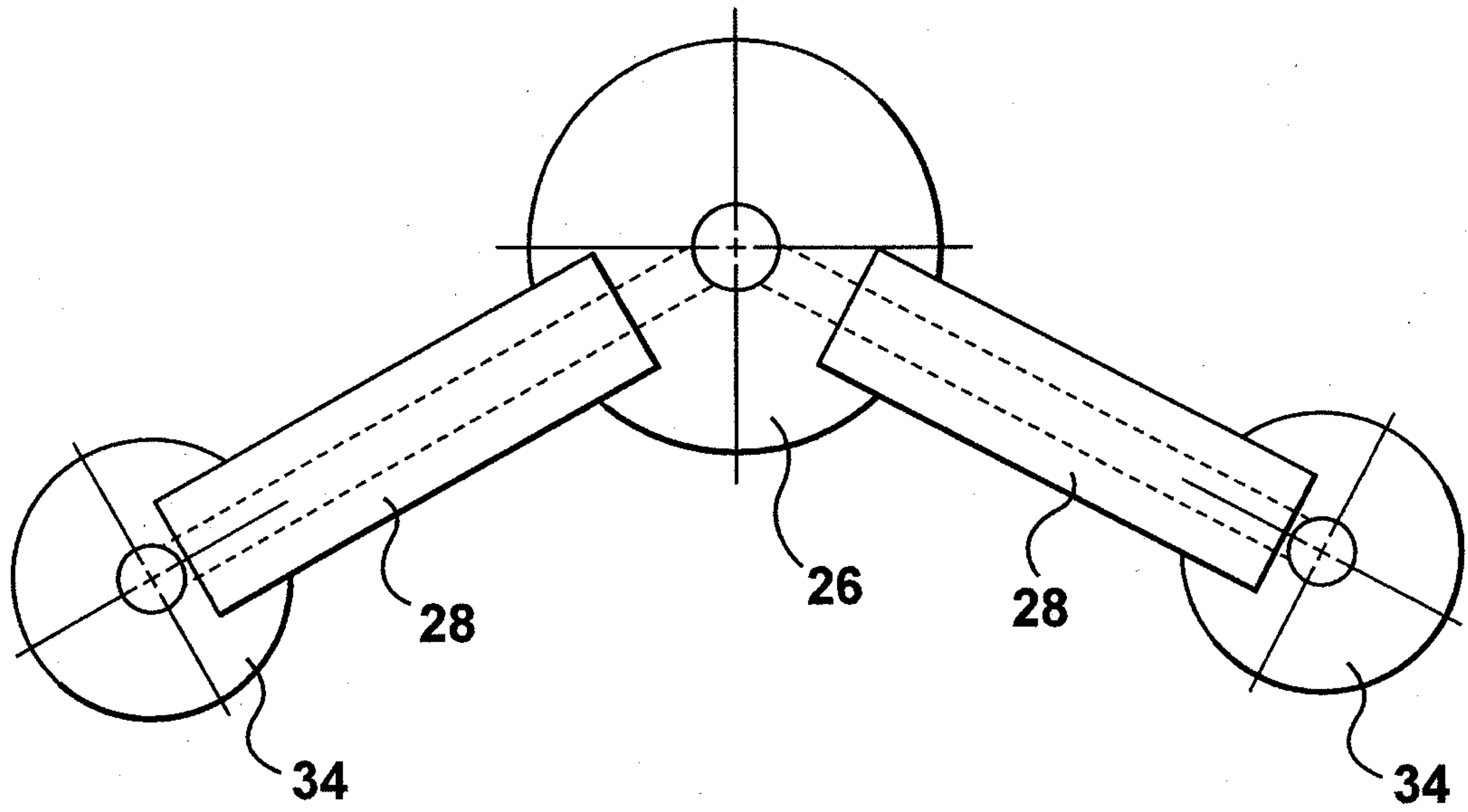
**FIG. 3**



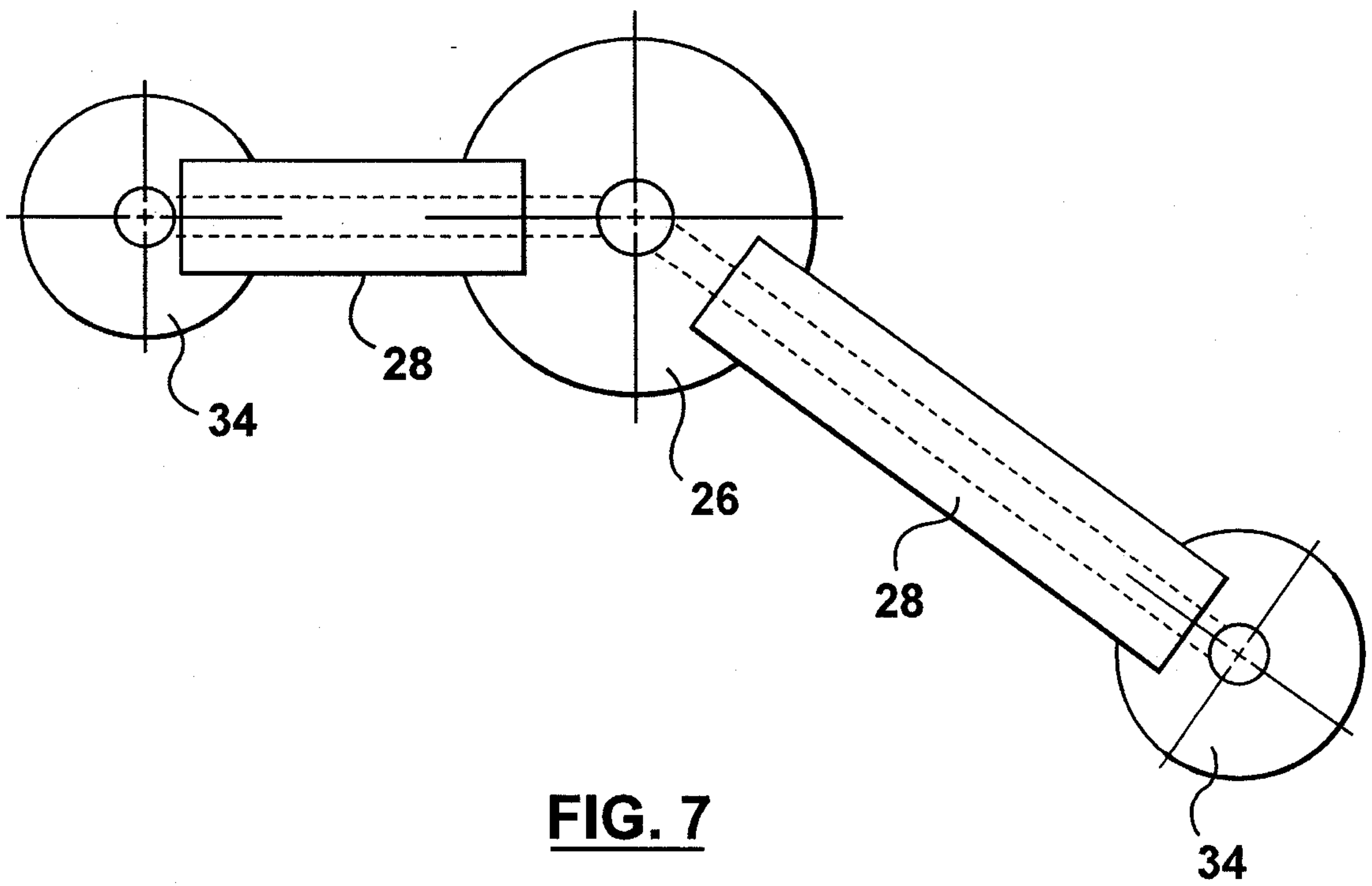
**FIG. 4**



**FIG. 5**

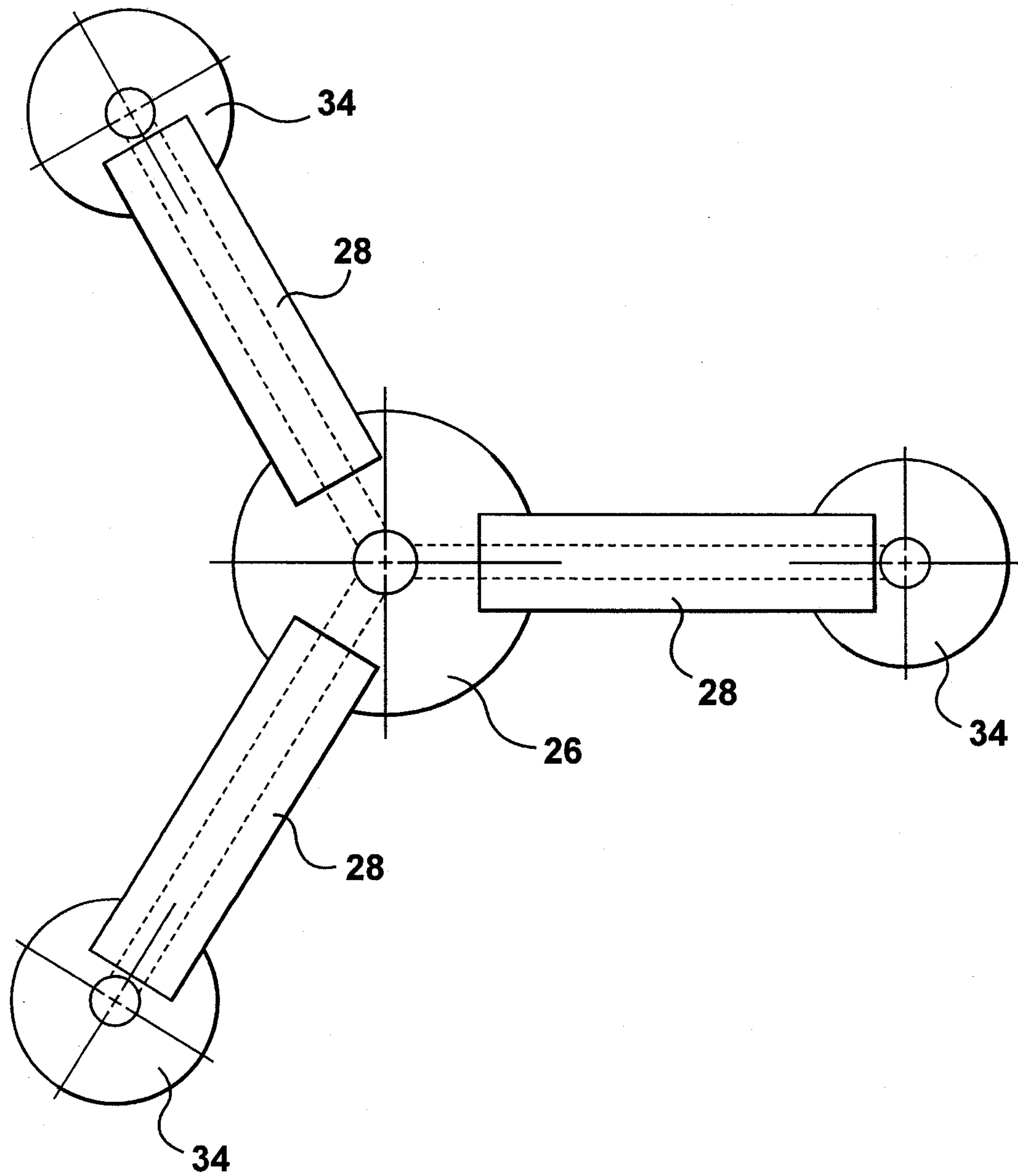


**FIG. 6**

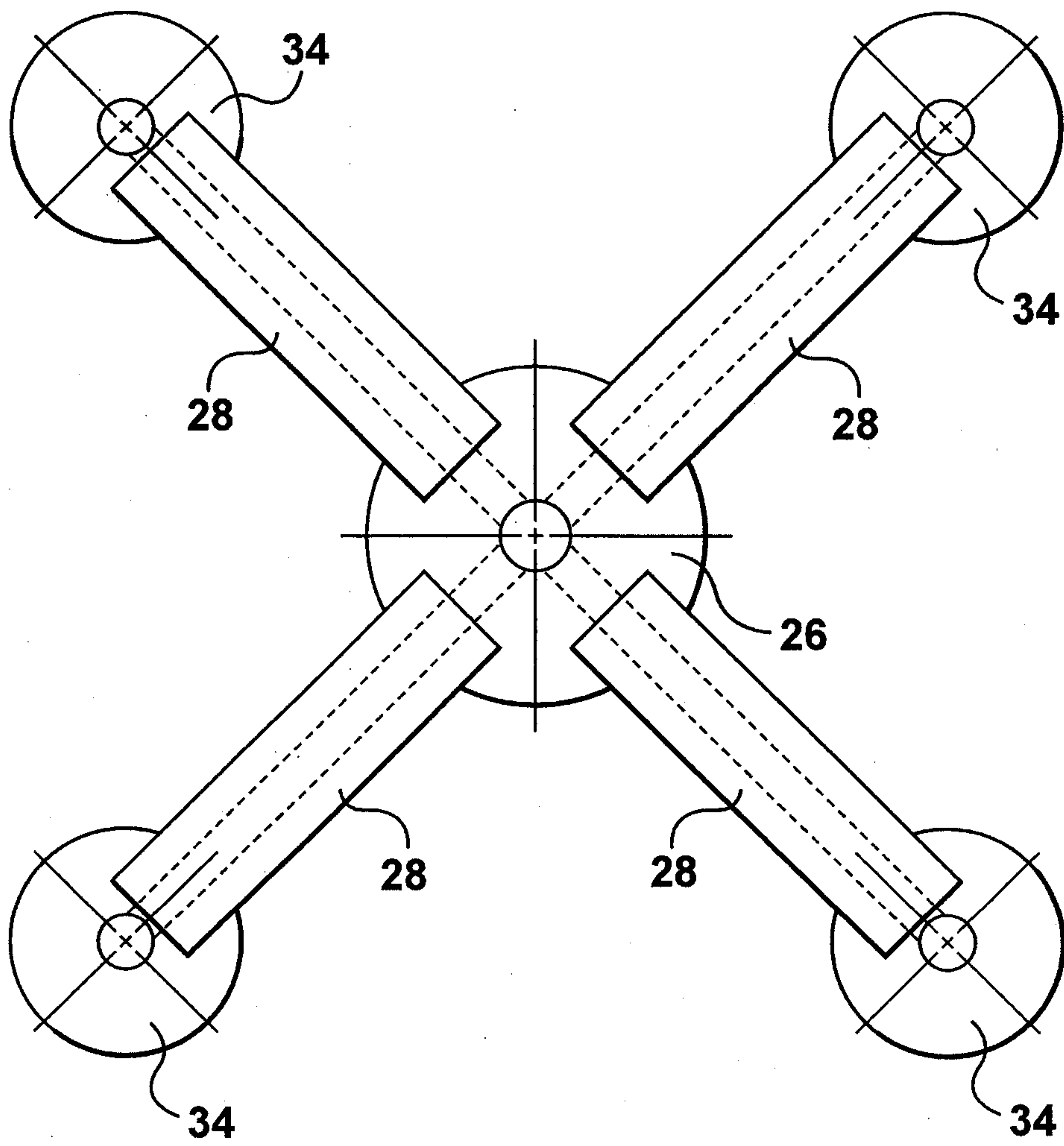


**FIG. 7**

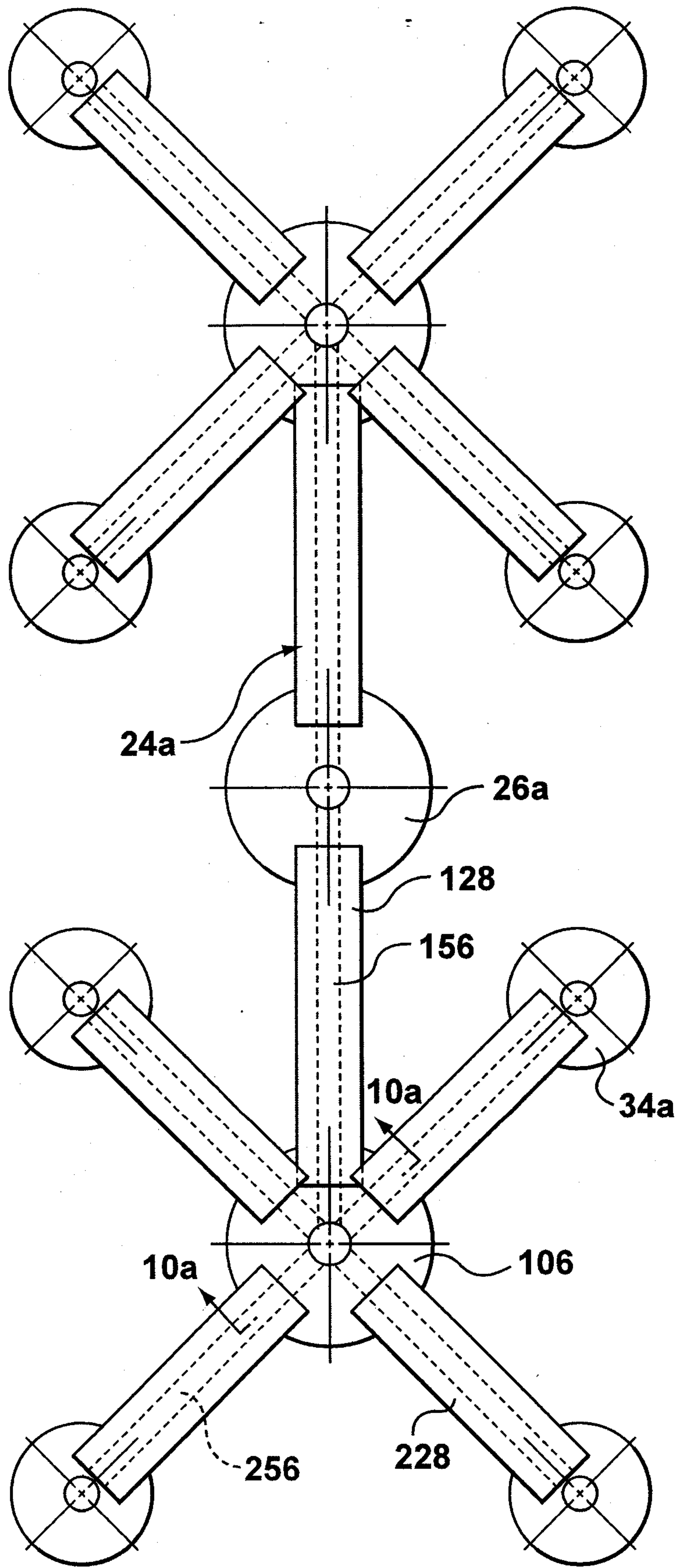




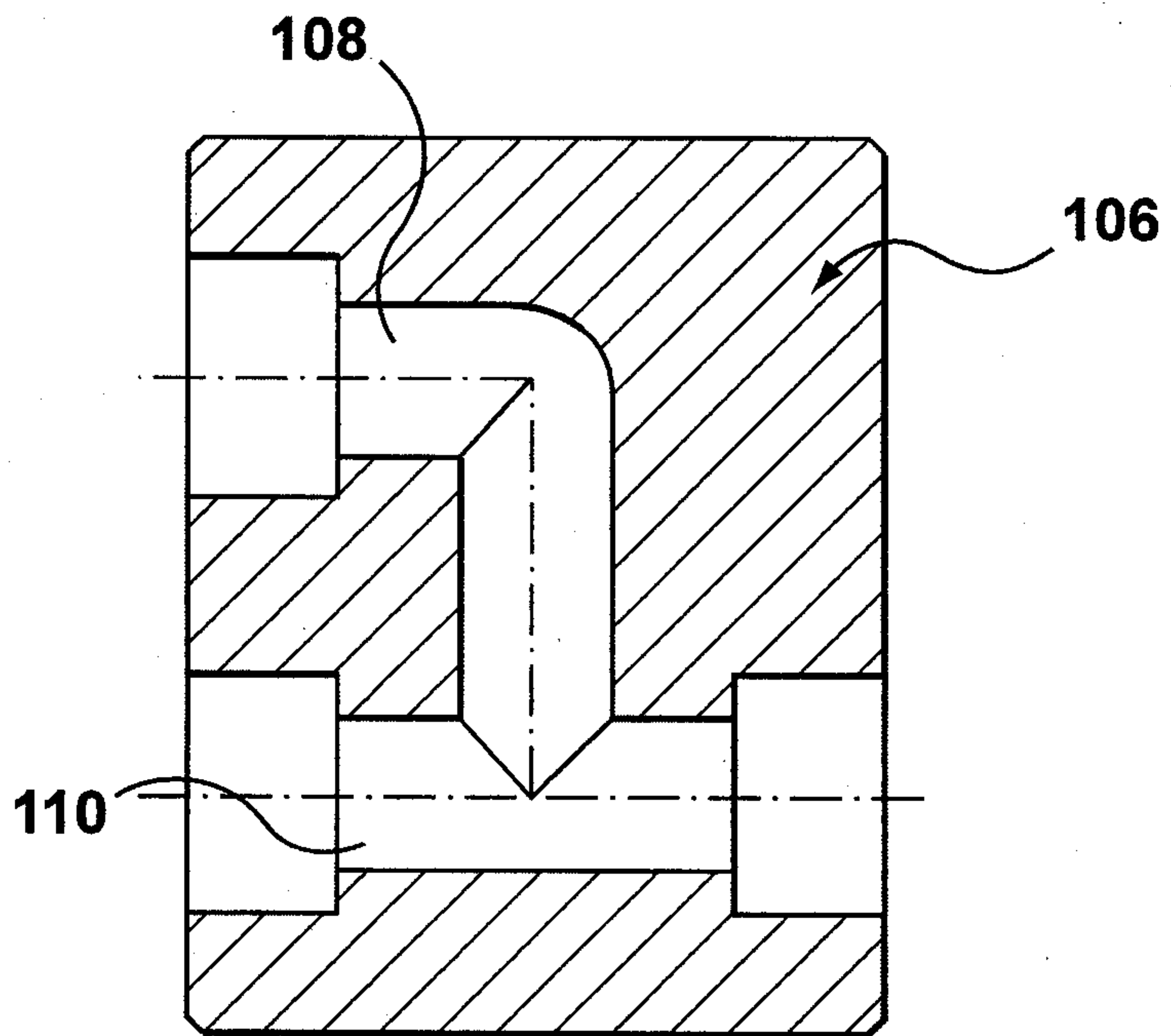
**FIG. 8**



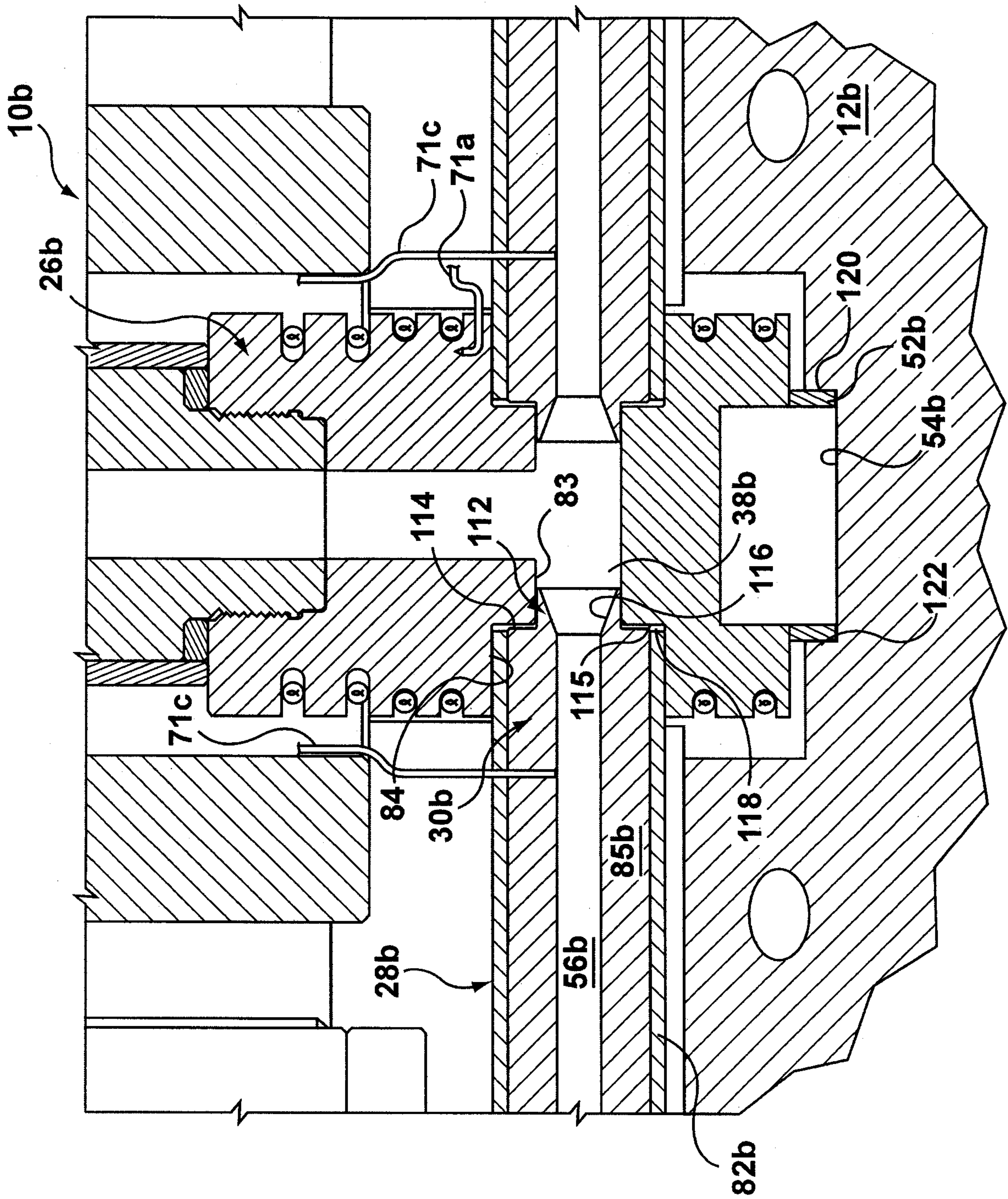
**FIG. 9**



**FIG. 10**



**FIG. 10a**



**FIG. 11**

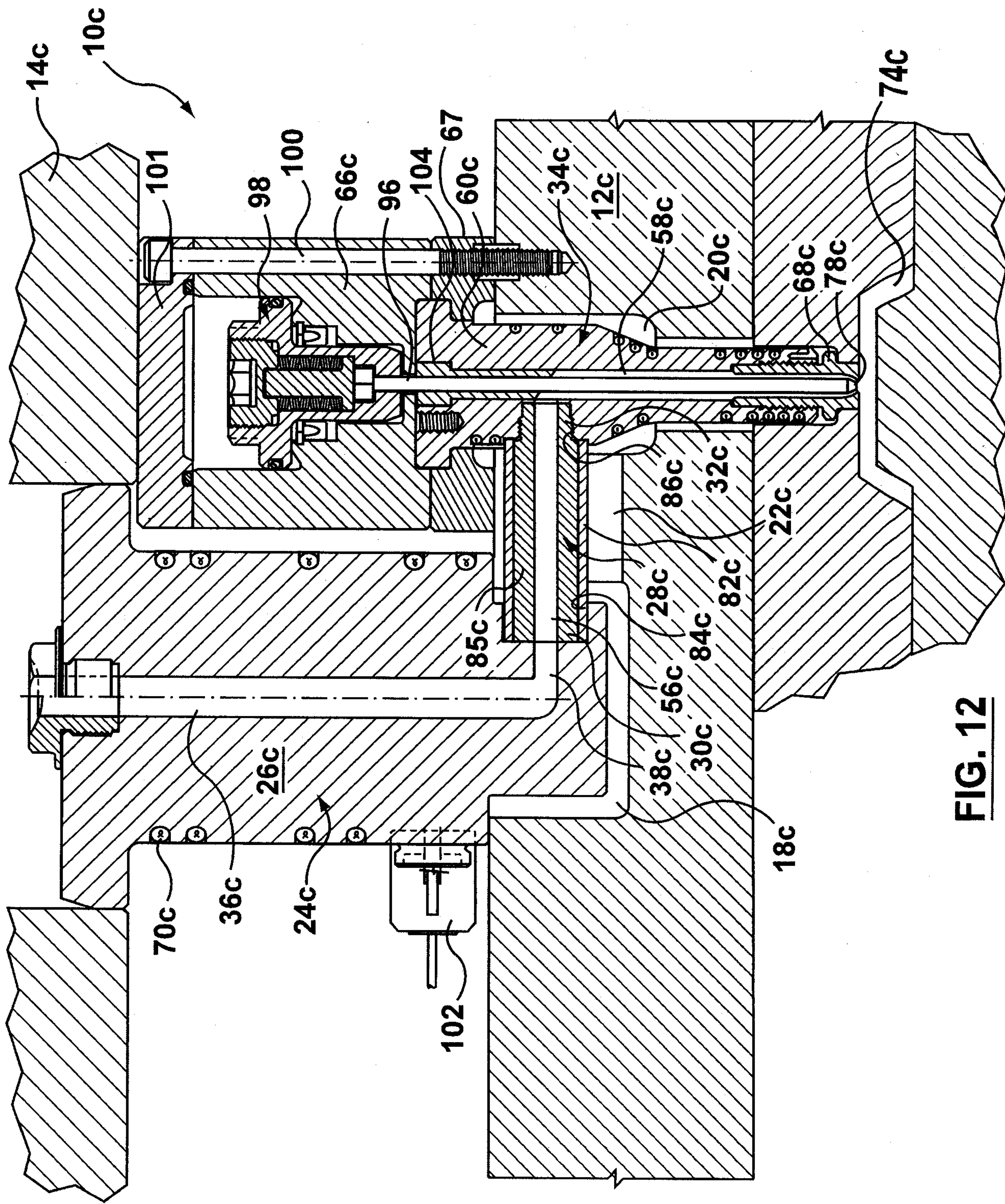
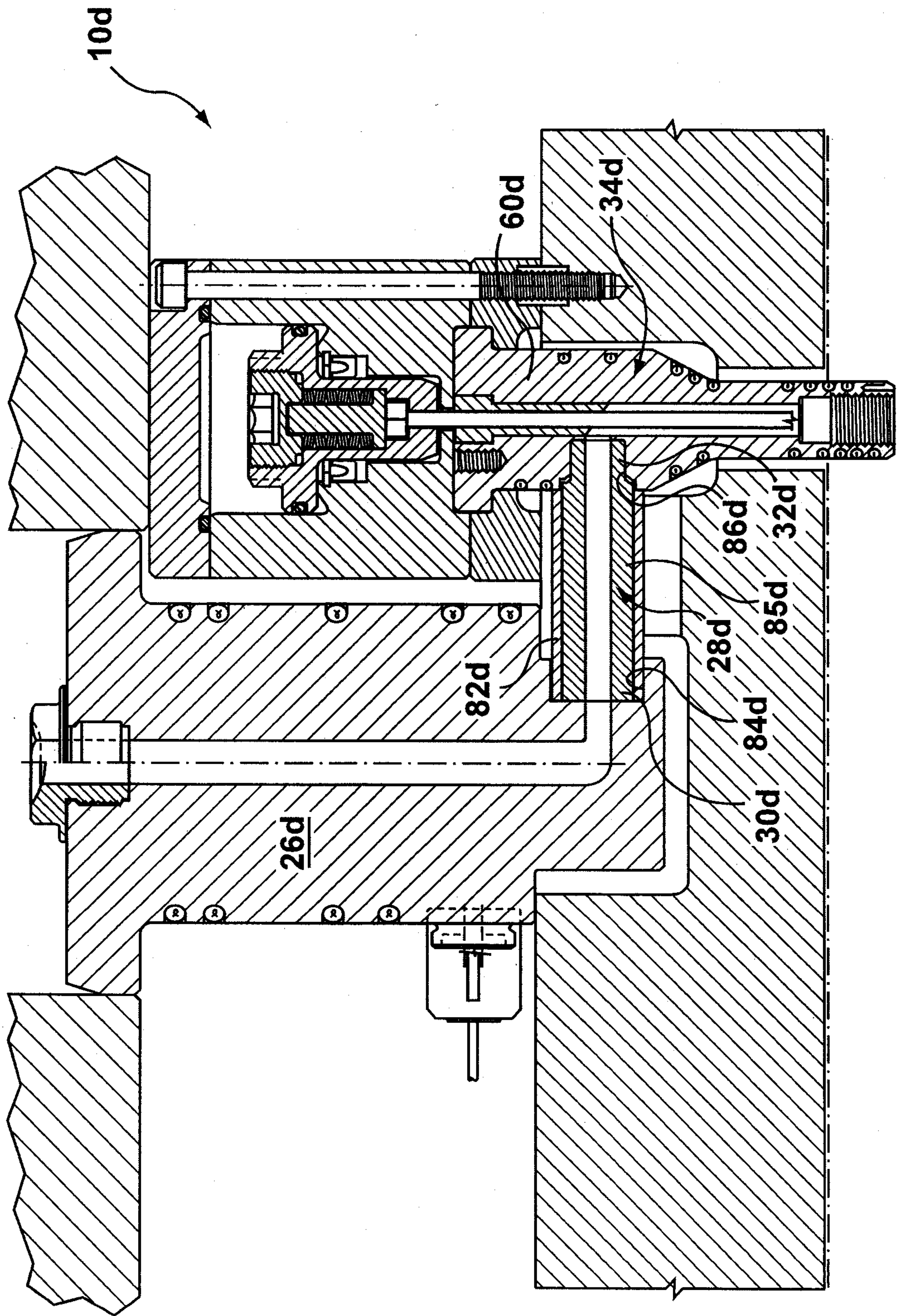
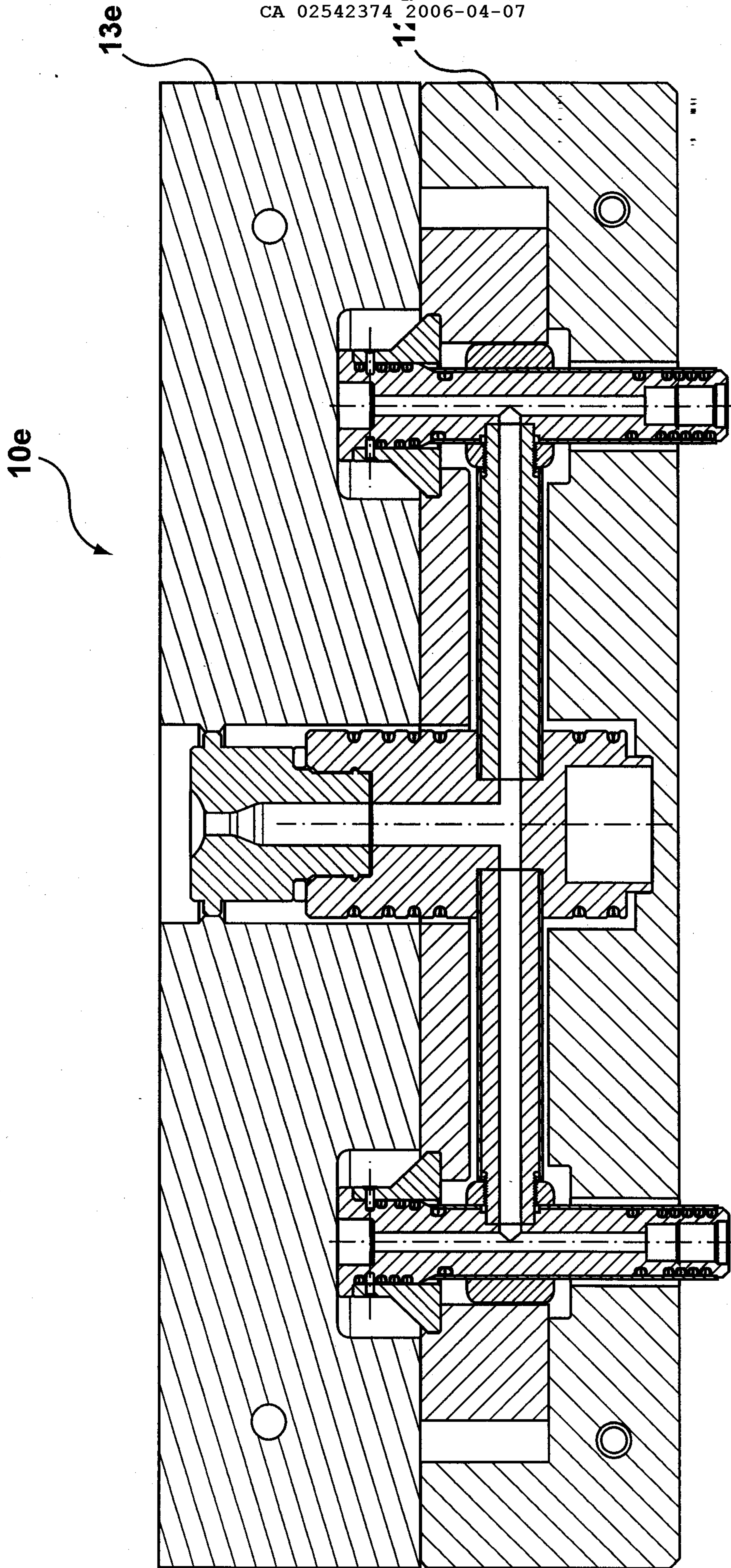


FIG. 12

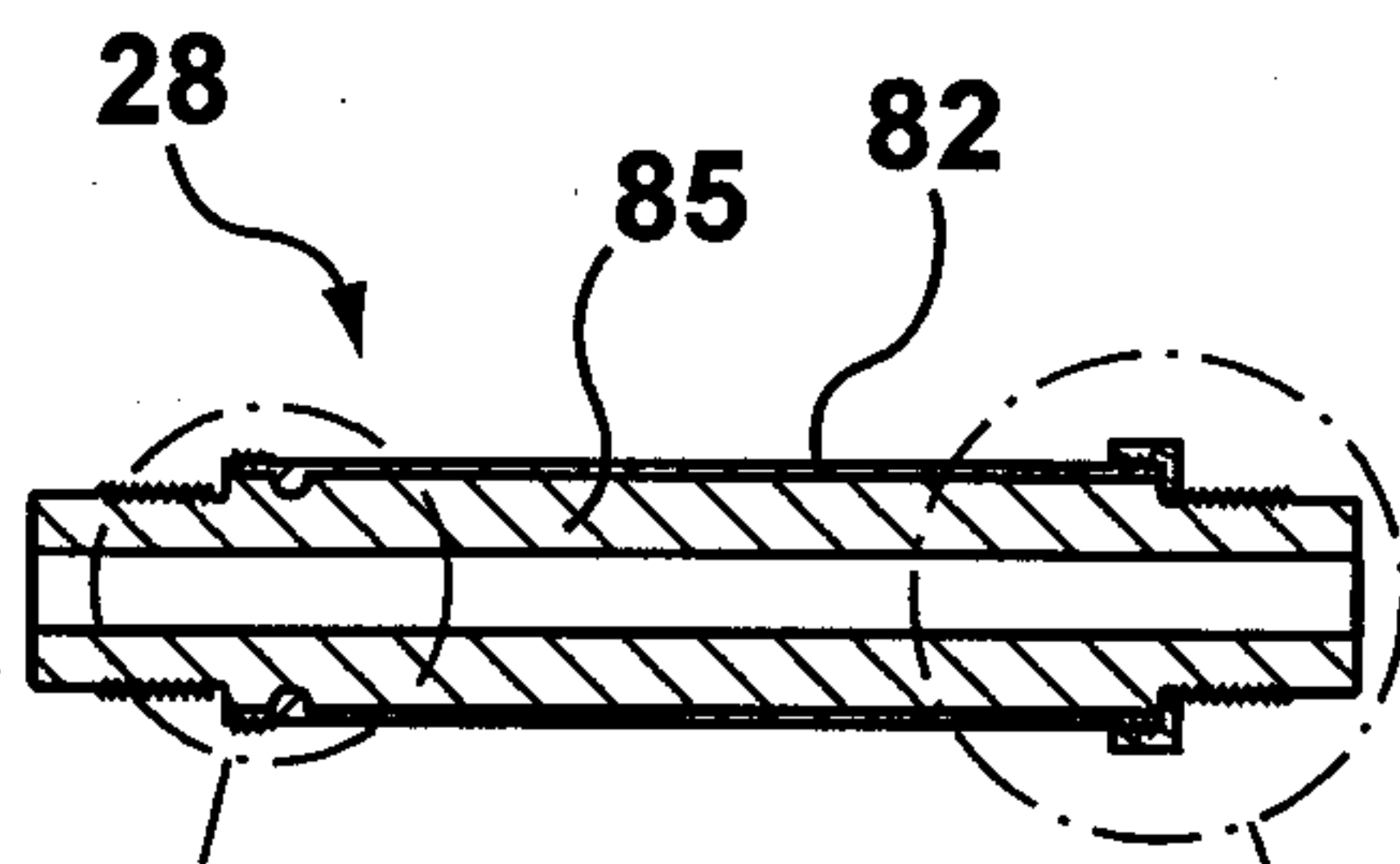


**FIG. 13**

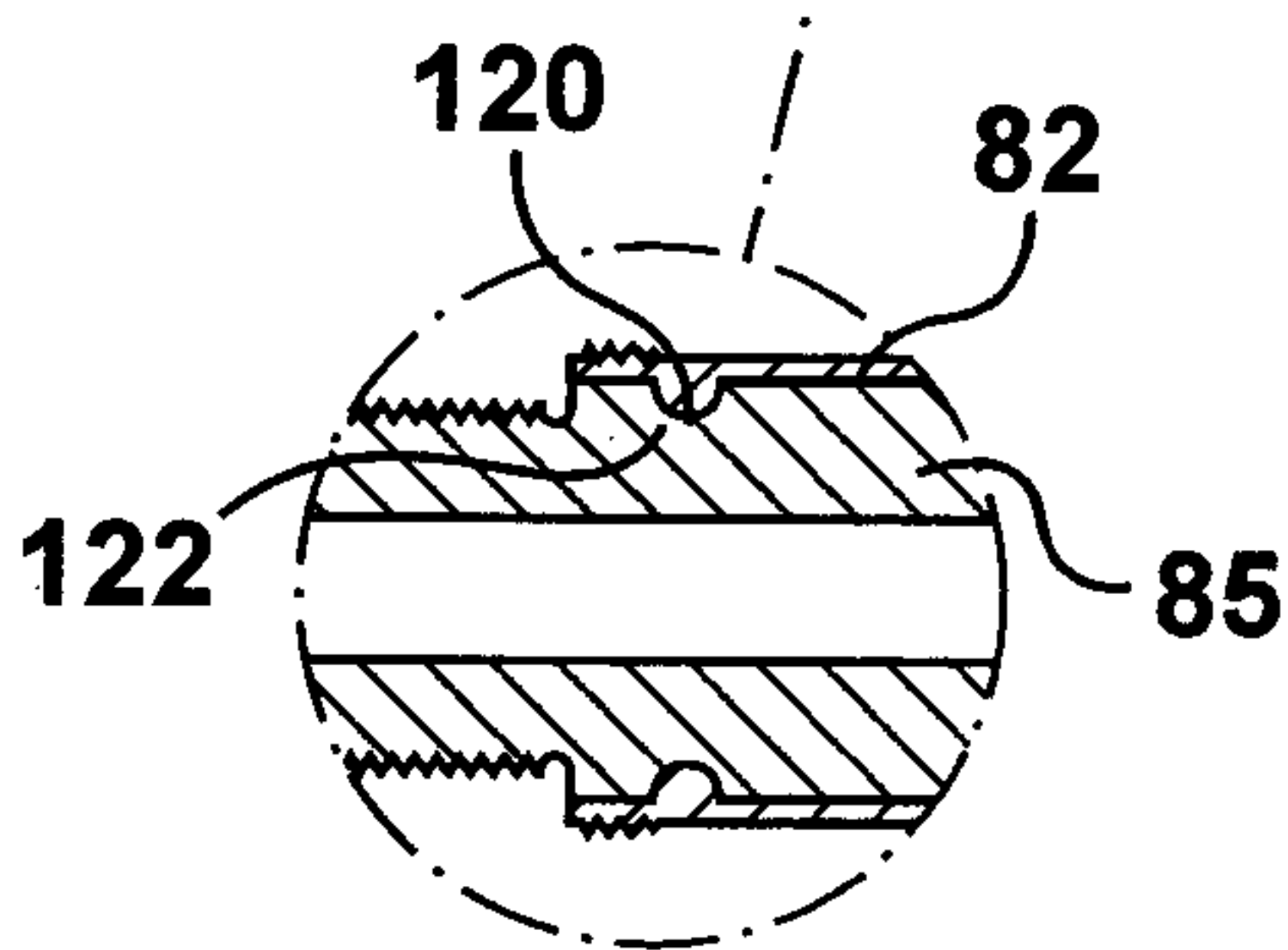


**FIG. 14**

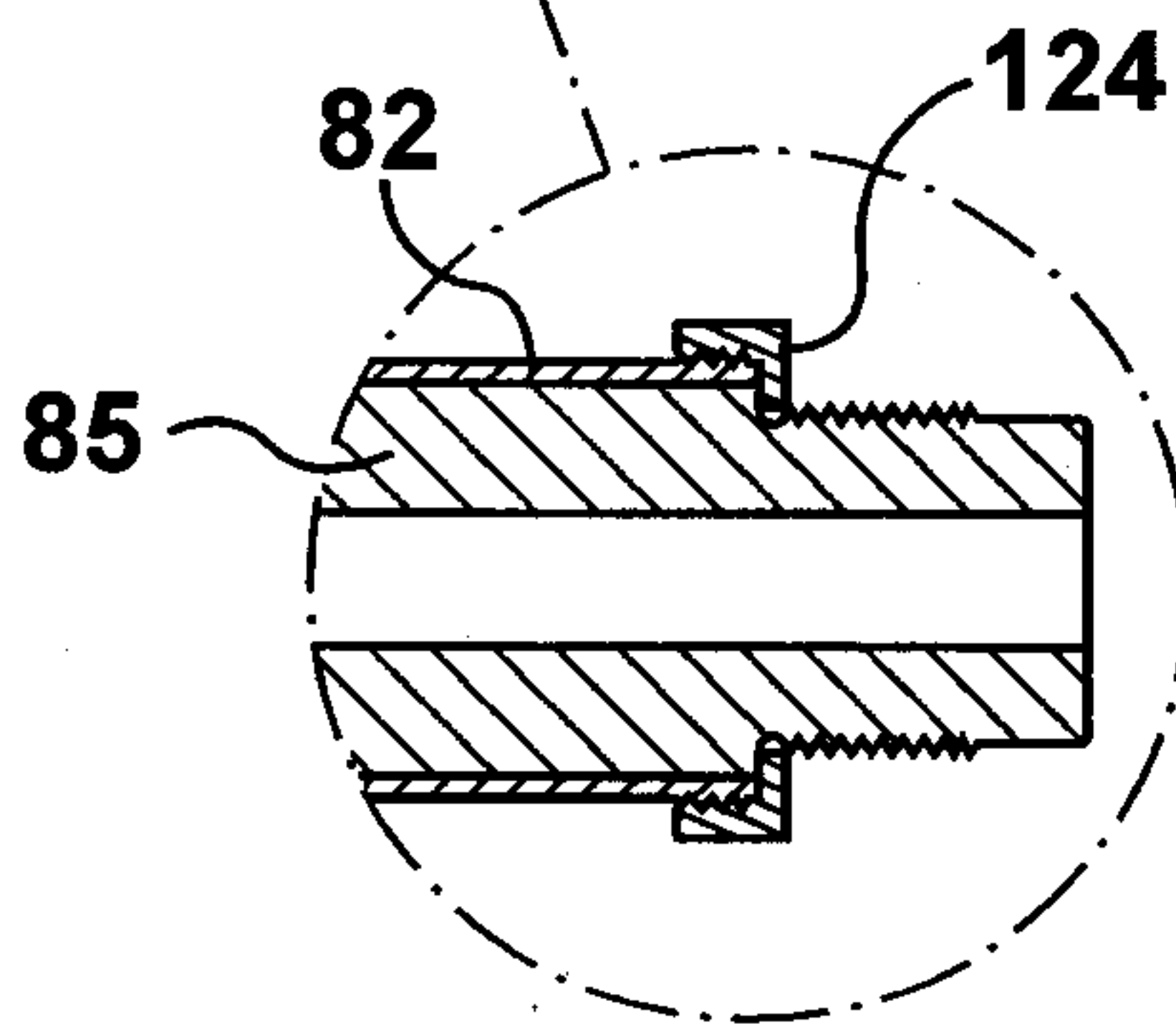




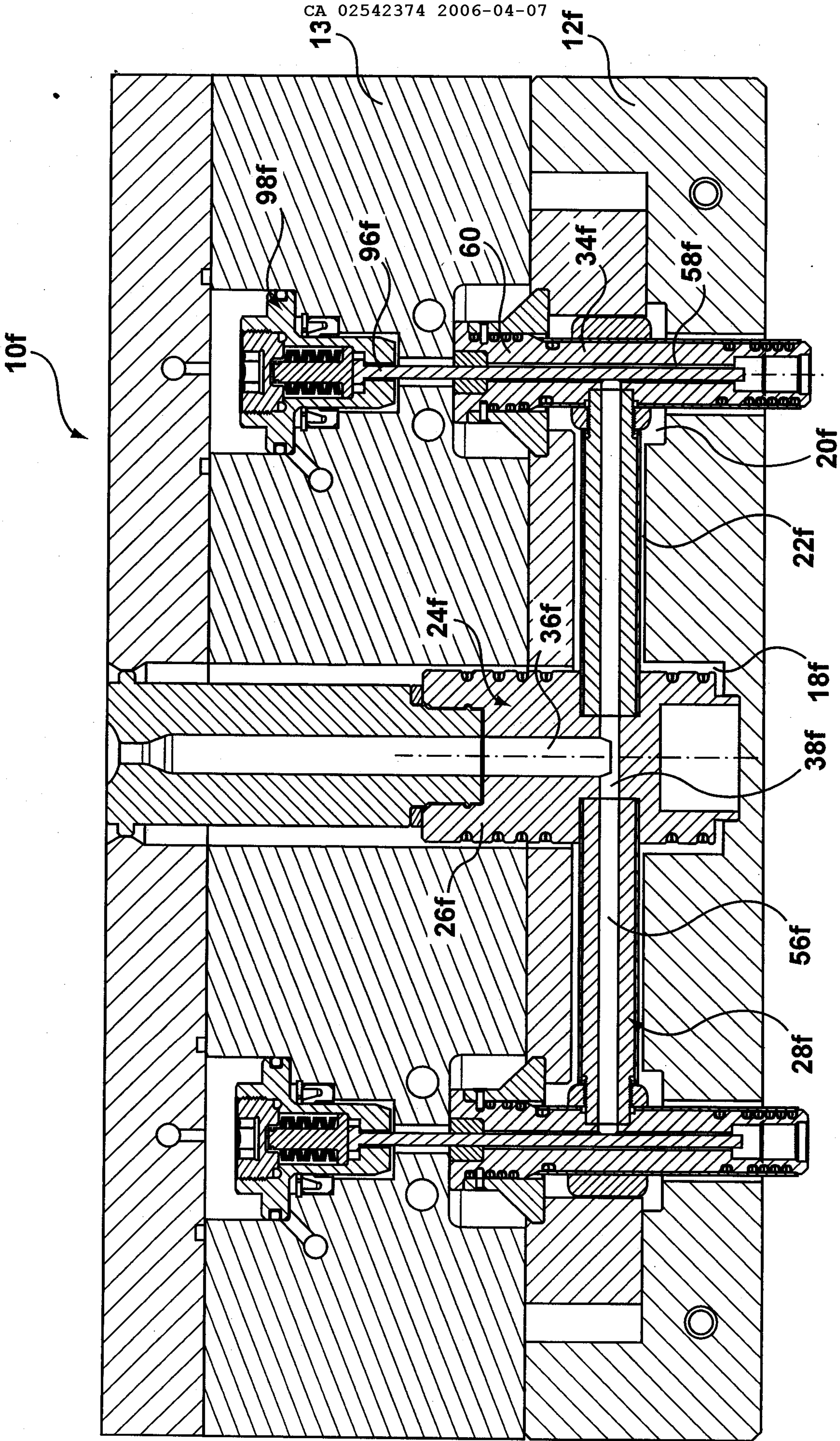
**FIG. 15**



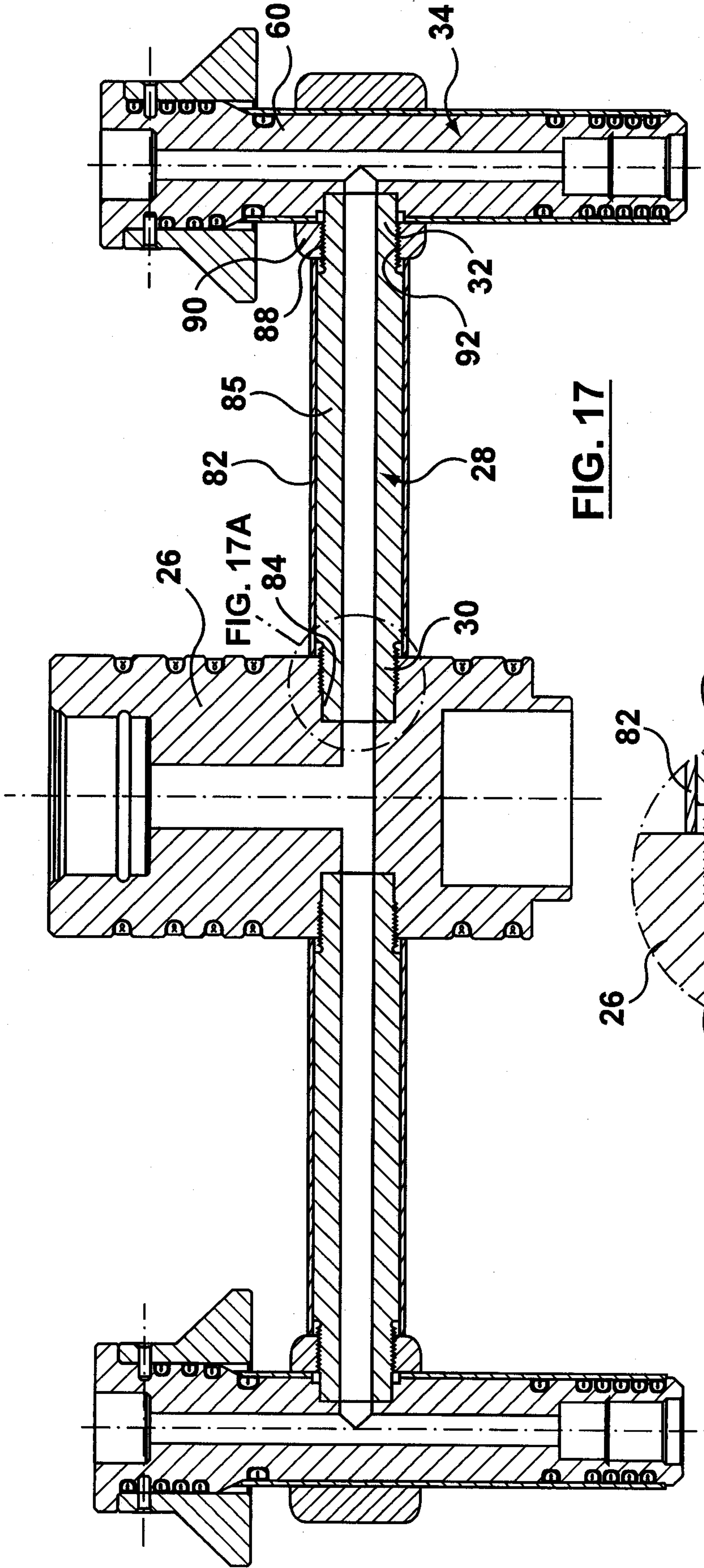
**FIG. 15A**



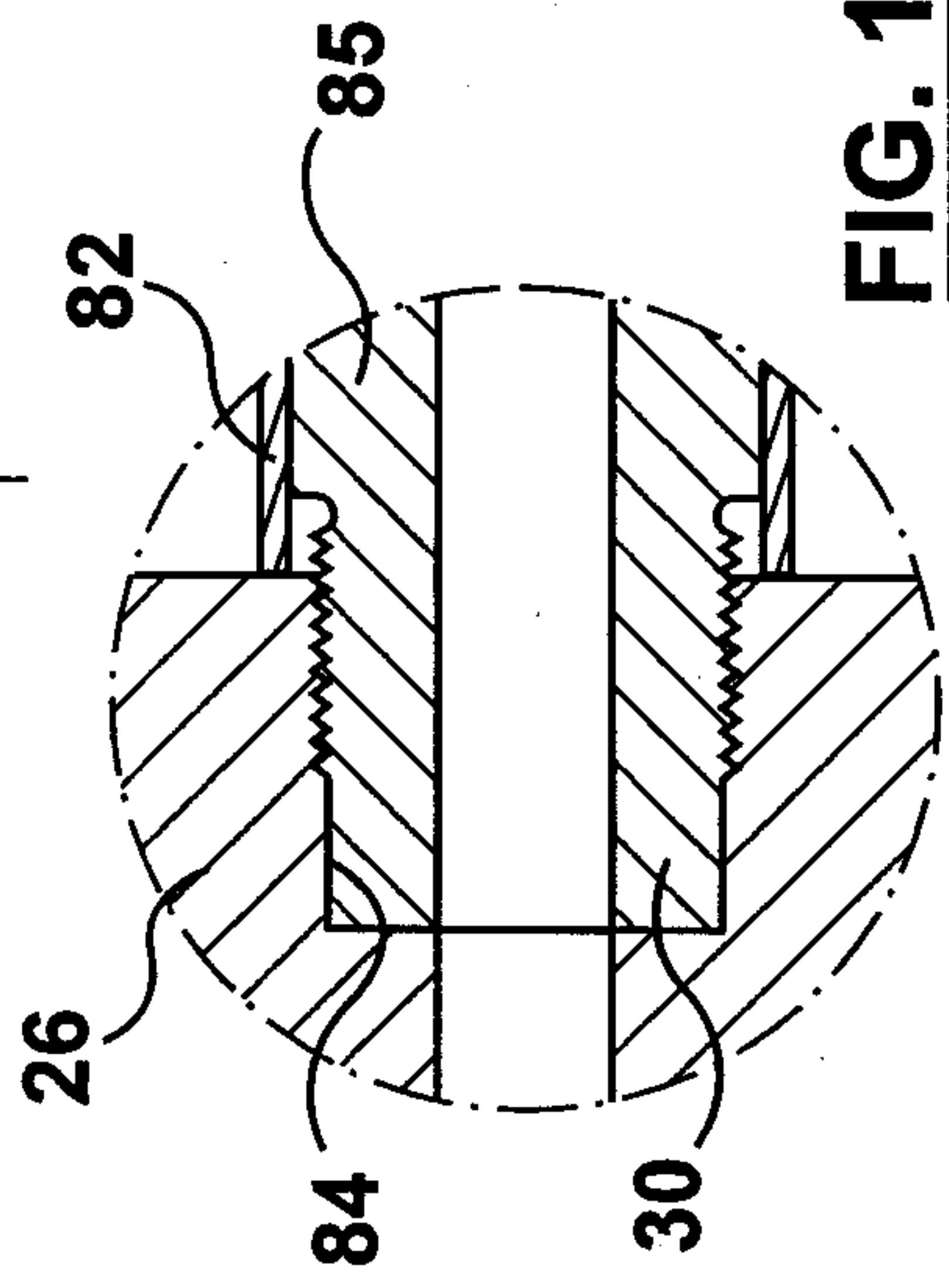
**FIG. 15B**



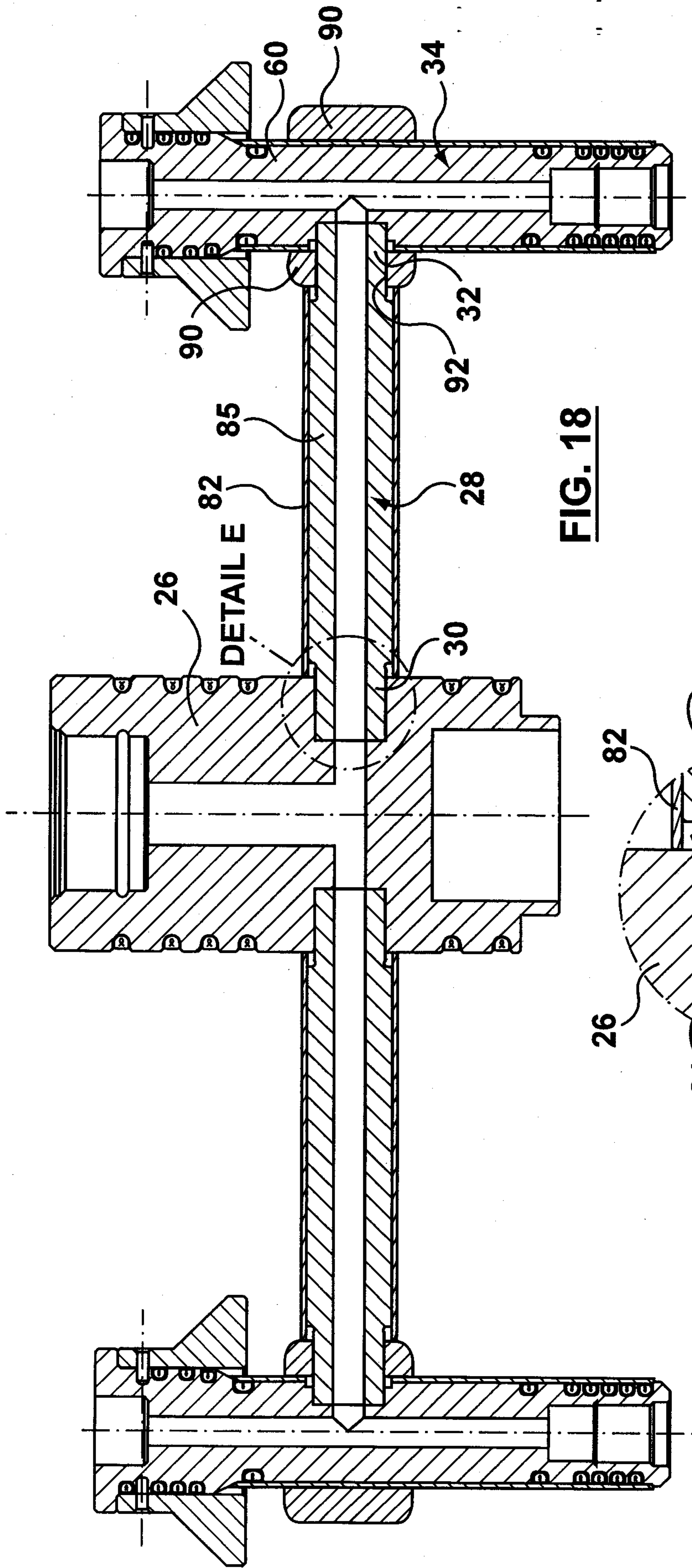
**FIG. 16**



**FIG. 17**



**FIG. 17A**



**FIG. 18**

**DETAIL E**  
**FIG. 18A**

