

(No Model.)

J. HOPE.  
GRINDING MACHINE.

No. 482,947.

Patented Sept. 20, 1892.

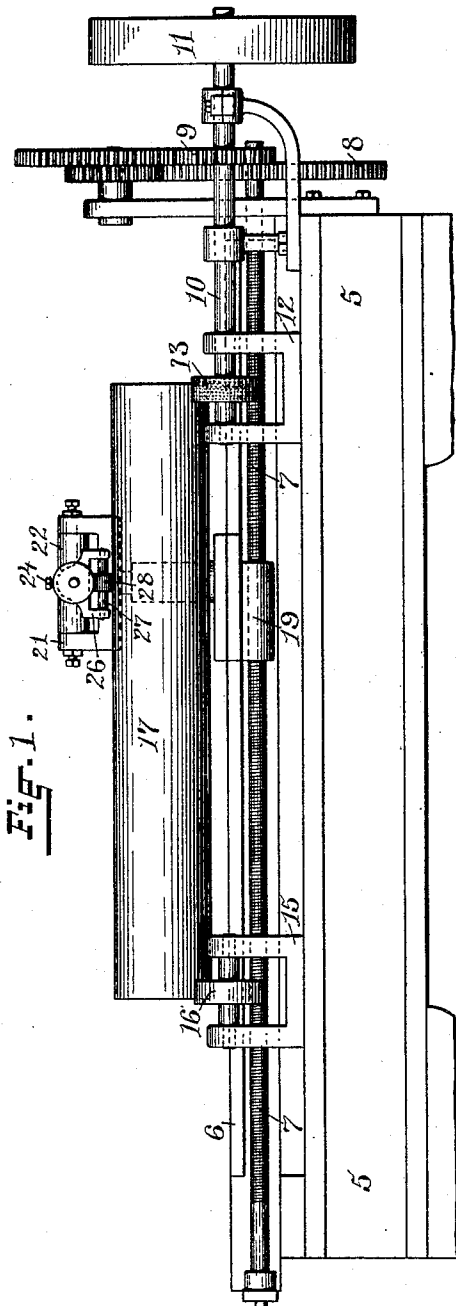

FIG. 1.

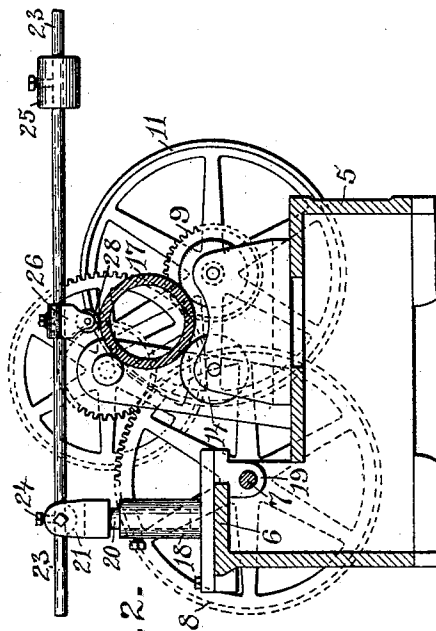

FIG. 2.

WITNESSES:

*Henry J. Miller*  
*Chas. H. Luther, Jr.*

INVENTOR:

*John Hope*  
*By Joseph A. Miller & Co.*  
*Attys.*

# UNITED STATES PATENT OFFICE.

JOHN HOPE, OF PROVIDENCE, RHODE ISLAND, ASSIGNOR TO THE JOHN HOPE & SONS ENGRAVING AND MANUFACTURING COMPANY, OF SAME PLACE.

## GROUNDING-MACHINE.

SPECIFICATION forming part of Letters Patent No. 482,947, dated September 20, 1892.

Application filed May 20, 1892. Serial No. 433,653. (No model.)

*To all whom it may concern:*

Be it known that I, JOHN HOPE, of the city of Providence, in the county of Providence and State of Rhode Island, have invented certain new and useful Improvements in Grounding-Machines; and I hereby declare that the following is a full, clear, and exact description of the same, reference being had to the accompanying drawings, forming part of this specification.

This invention has reference to improvements in devices for removing the varnish from printing-rollers in diagonal lines.

The object of the invention is to produce a machine which will automatically trace the diagonal grounding-lines through the varnish with which the surface of the printing-roll held in such machine is covered.

The further object of the invention is to produce a mechanical grounding-machine in which the printing-roll may be operated upon without truing up the bore of the same.

The invention consists in the peculiar construction of grounding mechanism and the combination therewith of novel means for driving the roll placed in the machine, as will hereinafter be more fully specified, and pointed out in the claims.

Figure 1 represents a front elevation of the improved grounding-machine and the printing-roll supported therein. Fig. 2 represents a vertical cross-sectional view of the same.

Similar numbers of reference designate corresponding parts throughout.

In the drawings, 5 indicates the bed of the machine, which is supported on suitable standards. In the rear of the bed extends longitudinally of the same a raised shelf or slideway 6, the ends of which are provided with bearings in which the worm-gear 7 is journaled, this worm-gear being rotated by the gear 8, secured thereto and engaging with a suitable train of gears intermeshing with each other and with a gear 9 on the drive-shaft 10, which is mounted in suitable bearings secured to the bed and is driven by a belt passing over the pulley 11, with which the drive-shaft 10 is journaled in the bearing-blocks 12, this portion of the shaft being provided with

a roughened disk or wheel 13, and a second disk 14 is carried on a shaft journaled between the sides of this block directly in the rear of the disk 13. At a suitable distance from the block 12 is a similar block 15, between the sides of which are journaled shafts carrying idle-disks 16, the shafts of these disks being in axial alignment with the shafts of the disks 13 and 14, the printing-roll 17 to be engraved being supported at the ends by these disks and being driven by contact with the roughened surface of the disk 13. By this means the printing-roll 17 need not be trued up at the ends and will be driven at a uniform speed.

The engraving device is supported by the standard 18, which has a base resting on the slideway 6, and is provided with a threaded clamp 19, which engages the worm-gear 7 and is driven thereby.

Secured in the standard 18 is a vertically-movable rod 20, the upper end of which is furnished with a branched member 21, in which is journaled the roll 22. This roll has a central transverse perforation through which the rod 23 is free to slide when not clamped therein by the set-screw 24. The rod 23 extends forward above and at a right angle with the length of the printing-roll 17. At its outer end this rod is supplied with a sliding weight 25, while near its center is adjustably secured the clamp 26, having downwardly-extending arms, between which are journaled the ends of a shaft 27, on which a milling-wheel 28 is carried. This shaft and its milling-wheel may be removed from the arms of the clamp and another substituted, and by this means grounds in which the spaces between the lines vary may be engraved.

Having thus described my invention, I claim as new, and desire to secure by Letters Patent—

1. In a grounding device, the combination, with two pairs of rotatable disks journaled in suitable bearings and a roll to be engraved, supported, and rotated thereby, of a traversing mechanism, a milling-tool supported thereby against the surface of the roll, and means for traversing said mechanism, as described.

2. In a ground-engraving machine, the com-

5 bination, with the disks 13 and 14, journaled in the block 12, the disks 16, journaled in the block 15, said blocks being supported on a suitable base, and means for rotating one or more of said disks, of the worm 7, journaled in suitable bearings, a traversing mechanism carrying a milling-tool and provided with a threaded clamp for engaging said worm, and means for rotating said worm, as described.

10 3. In a ground-engraving machine having a traversing engraving device operated by a worm-gear, the disks 13 and 14 and 16 16,

suitably mounted and adapted to rotate the article to be engraved, and means intermediate the disk 13 and said worm whereby they are simultaneously rotated, as and for the purpose described. 15

In witness whereof I have hereunto set my hand.

JOHN HOPE.

Witnesses:

JONATHAN BOYD,  
JOSEPH A. MILLER, Jr.