

Feb. 7, 1928.

1,658,286

L. G. DARLING

SMOKING PIPE

Filed April 22, 1925

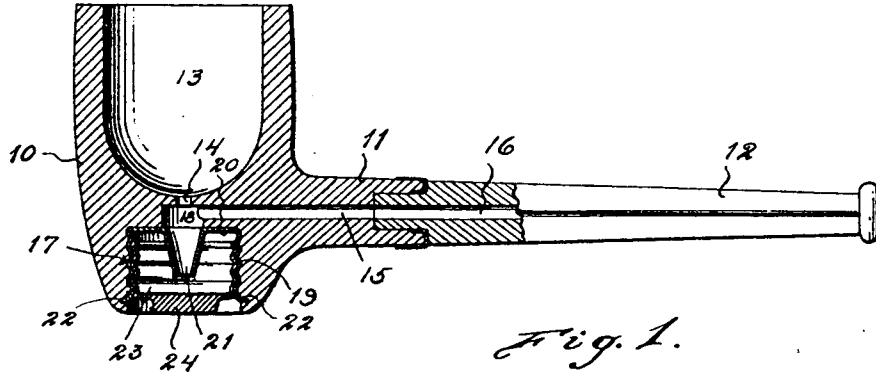

Fig. 1.

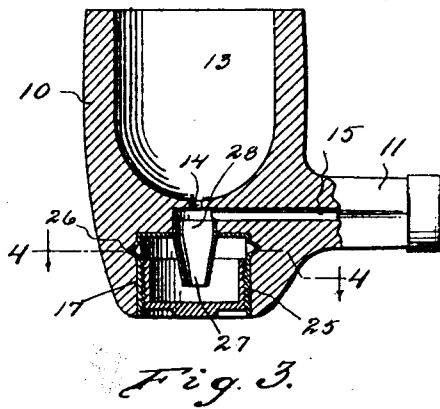

Fig. 3.

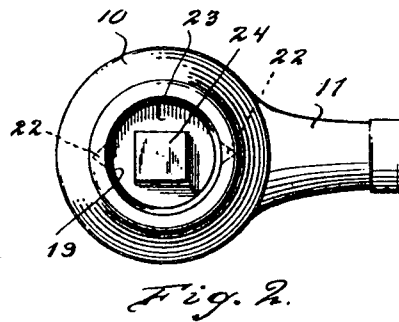

Fig. 2.

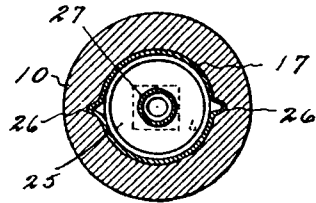

Fig. 4.

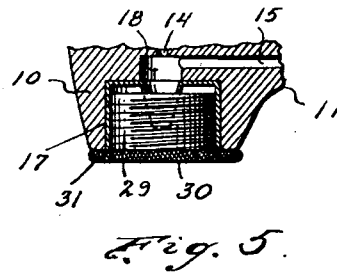

Fig. 5.

Inventor

L. G. Darling

By John Milton Jester
his Attorney

UNITED STATES PATENT OFFICE.

LEON G. DARLING, OF BOISE, IDAHO.

SMOKING PIPE.

Application filed April 22, 1925. Serial No. 24,978.

This invention relates to smoking pipes and has for its general object the provision of a pipe provided with means for receiving any accumulations of saliva and the like so
5 that the same will be prevented from wetting the tobacco or being drawn into the smoker's mouth.

An important and more specific object is the provision of a pipe provided with a removable receptacle into which the saliva or
10 other moisture may pass, the construction being such that such matter cannot possibly gain access to the tobacco regardless of the position in which the pipe may be placed,
15 the receptacle being unspillable.

Another object is the provision of a pipe which may have the same appearance as an ordinary pipe and not be clumsy as the result of the application of the receptacle and
20 its associated parts, the device being furthermore entirely enclosed so as not to be conspicuous.

Still another object is the provision of a device formed with a chamber within which
25 is secured a shell member having removably engaged therein a receiving cup or well, the shell member having a nipple extending down into the cup and so arranged that any accumulation within the cup cannot spill
30 back through the nipple regardless of the position in which the pipe may be placed or carried.

An additional object is the provision of a device of this character which will be simple and inexpensive to manufacture, positive in action, efficient and durable in service,
35 and a general improvement in the art.

With the above and other objects and advantages in view, the invention may consist
40 in the details of construction and the arrangement of parts to be hereinafter more fully described and claimed, and illustrated in the accompanying drawing in which:

Figure 1 is a longitudinal section through
45 a pipe embodying my invention,

Figure 2 is a bottom plan view thereof,

Figure 3 is a view similar to Figure 1 showing a variation in the manner of securing certain elements in place and holding
50 them together,

Figure 4 is a horizontal cross section taken on the line 4-4 of Figure 3 and looking in the direction of the arrows, and

Figure 5 is a fragmentary section showing
55 a modified form of cup.

Referring more particularly to the drawing I have shown a pipe including a body portion 10 on which is formed the usual extension 11 with which is connected the stem or bit 12, the mode of connection being an
60 immaterial detail, though in the present instance it is represented as being of the slip joint type. The body portion 10 is formed to provide a bowl 13 for holding the tobacco and at the bottom of this bowl is a passage
65 14 permitting the smoke to be drawn from the bowl and through the passages 15 and 16 in the extension 11 and stem 12 respectively.

The distinguishing feature of the invention is the provision of a chamber 17 at the lower portion of the body 10 and communicating with a smaller chamber 18 into which the passages 14 and 15 lead. These features
70 are common to all modifications of the invention.

Referring especially to Figure 1 I have shown a metallic shell 19 fitted within the chamber 17 and secured thereto in some suitable manner which might be varied as will
80 be explained. This shell is represented as having a top wall 20 fitting snugly against the top wall of the chamber 17 and formed with a central opening surrounded by a depending preferably tapered nipple 21 which
85 terminates at an intermediate point in the chamber. This nipple may be secured to or formed integrally with the shell as indicated in Figure 1 and the top surface of the wall
90 20 may be flush as shown in the same figure, though if desired the nipple could be arranged to extend upwardly into the chamber 18 to a slight distance, as shown in Figure 3, if found advisable. The shell 19 is
95 represented as threaded, the threading being accomplished by pressing or otherwise shaping the shell in a well known manner. The pressed threaded shell disclosed in Figure 1 might be replaced by one having a cut thread as indicated in Figure 5 as this
100 variation is within the scope of the invention.

While it is true that the shell 19 might be secured within its receiving chamber in different ways. I have in Figures 1 and 2 disclosed prongs, lugs or tines 22 at the lower
105 or open end thereof which are forced, by any desired means, into penetrating engagement with the body at the side wall of the chamber 17. The purpose of these elements 22 110

is not only to prevent withdrawal of the shell from the pipe but also to prevent rotation thereof.

Removably engaged within the shell 19 is a cup 23 here shown as screwed into place, the threads being formed either by pressing the metal of the shell, as indicated in Figure 1, or by cutting as shown in Figure 5. To facilitate moving the cup it is preferable that it be equipped with an angular projection 24 which may be readily grasped by the fingers so that the cup may be removed or replaced.

In the operation it will be apparent that the smoke drawn from the bowl of the pipe will pass through the passage 14 into the chamber 18 and then out to the smoker's mouth through the passages 15 and 16. Any accumulation of saliva will of course drop into and through the nipple 21 into the cup 23 where it will remain until the cup is removed and cleaned. Owing to the peculiar formation and location of the nipple it is apparent that any matter accumulating within the cup cannot possibly re-enter the nipple and gain access to the bowl regardless of the position in which the pipe may be placed. This feature will insure that the tobacco will remain dry.

In Figure 3 the shell 25 is shown as held in place within the body by means of outstruck projections 26 formed by punching the metal outwardly subsequent to the insertion of the shell within its receiving chamber. Likewise, this figure shows the nipple 27 corresponding to the above described nipple 21 as having an upward extension 28 fitting within the chamber 18. Then too the threads in this figure are illustrated as being of the cut type.

The modification illustrated in Figure 5 is substantially the same as in Figure 3 except that the cup 29 corresponding to the cup 23 has its lower end enlarged to define a base portion 30 provided with a milled or knurled edge 31 constituting a finger grip instead of the angular projection 24 shown in Figures 1 and 3.

All forms are designed along the same general lines inasmuch as each discloses a shell having the depending central nipple and containing the removable cup. Further-

more the operation will be the same in every instance, the differences existing being only such as might occur as the result of preference in manufacture.

From the foregoing description and a study of the drawing it will be apparent that I have thus provided a simply constructed, inexpensive and highly satisfactory pipe construction in which ample means is provided for taking care of the unavoidable accumulation of saliva and nicotine and conveying this matter to the removable receptacle so that the accumulation cannot either cause wetting of the tobacco or be drawn into the user's mouth along with the smoke. The device is sanitary and will make smoking less harmful and far more enjoyable. A distinct feature of importance is the location and arrangement of the saliva and nicotine receiving receptacle with respect to the smoke passage. It will be noted that the smoke never passes through the receptacle on its way to the smoker's mouth and in this way the flavor of the smoke is unimpaired as it never comes in contact with the moisture and waste matter accumulated within the cup or receptacle.

While I have shown and described a preferred embodiment of the invention, it should be understood that I reserve the right to make such changes in the form, construction and arrangement of parts as will not depart from the spirit of the invention or the scope of the subjoined claim.

Having thus described the invention, I claim:

In a smoking pipe, a body member having a bowl opening out at the top and a chamber opening out at the bottom and formed with a smoke outlet and with a passage establishing communication between the bowl and chamber, a shell member located within the chamber and having means penetratingly engaging within the body to effect anchoring, the shell member having a top with a depending nipple registering with the passage with an upstanding portion extending thereinto, and a cup removably mounted within the shell member and entirely enclosed there-within.

In testimony whereof I affix my signature.
LEON G. DARLING.