

March 12, 1935.

R. F. DIRKES ET AL  
TAPE CONTROL MECHANISM

1,994,017

Filed June 9, 1932

2 Sheets-Sheet 1

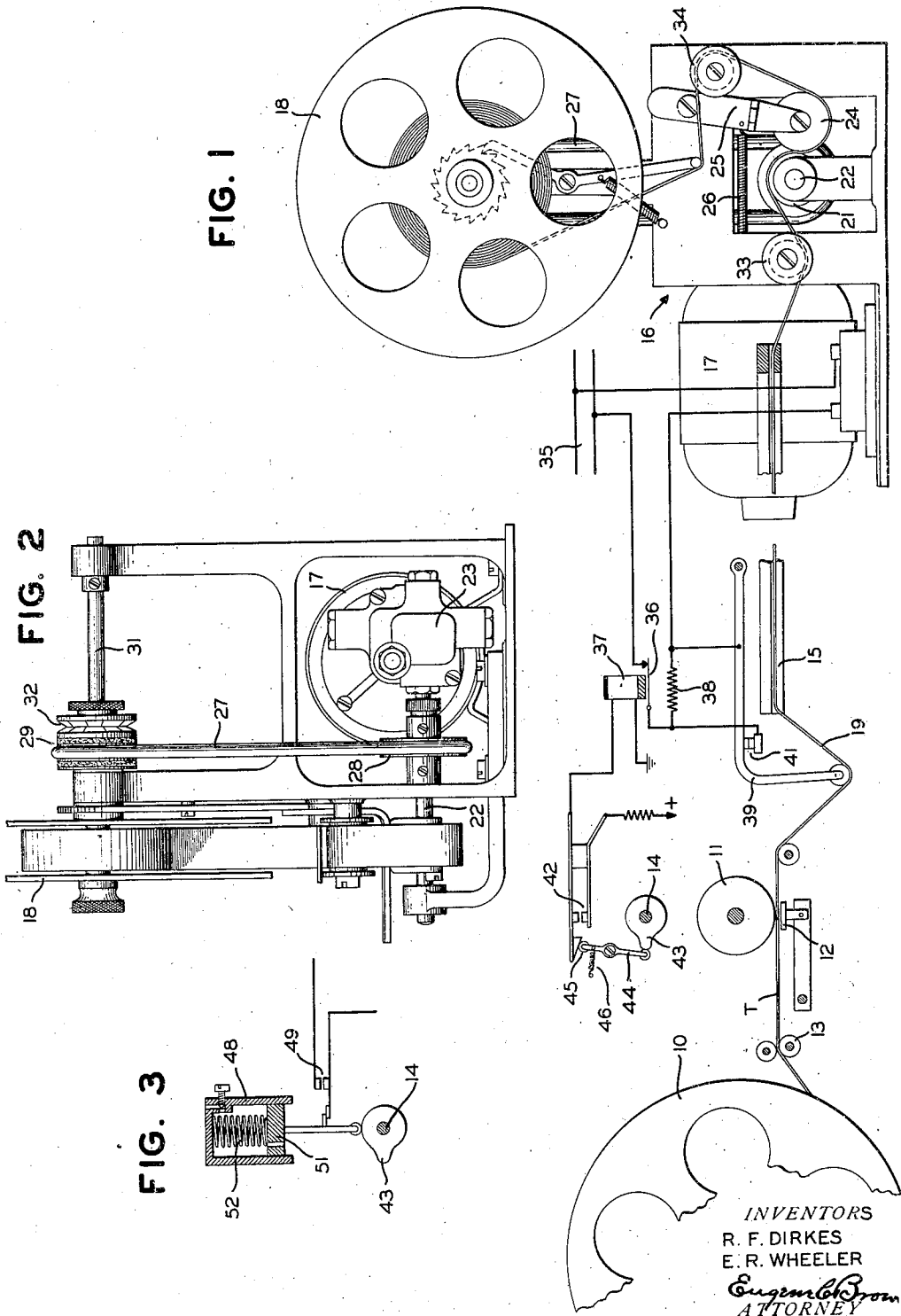

INVENTORS  
R. F. DIRKES  
E. R. WHEELER  
*Eugene C. Brown*  
ATTORNEY

March 12, 1935.

R. F. DIRKES ET AL

1,994,017

TAPE CONTROL MECHANISM

Filed June 9, 1932

2 Sheets-Sheet 2

FIG. 4

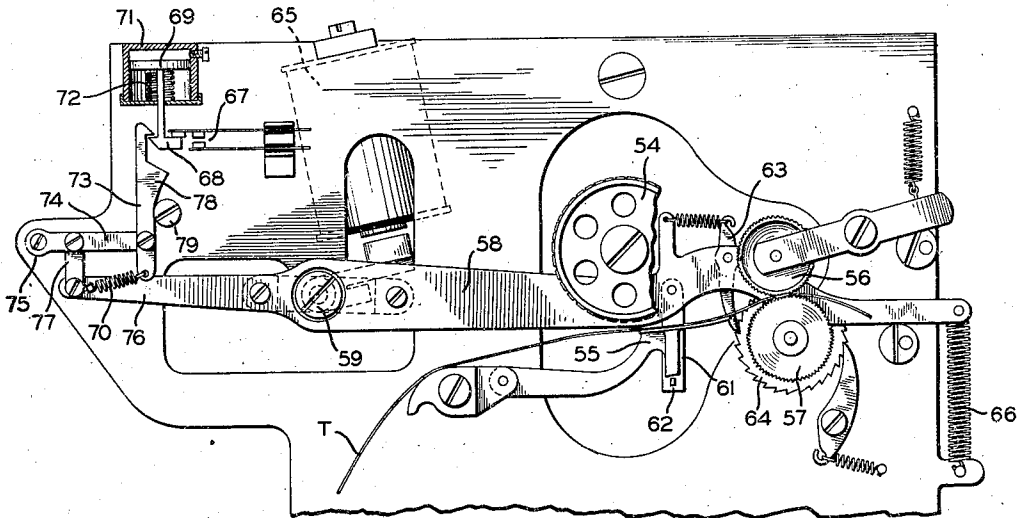
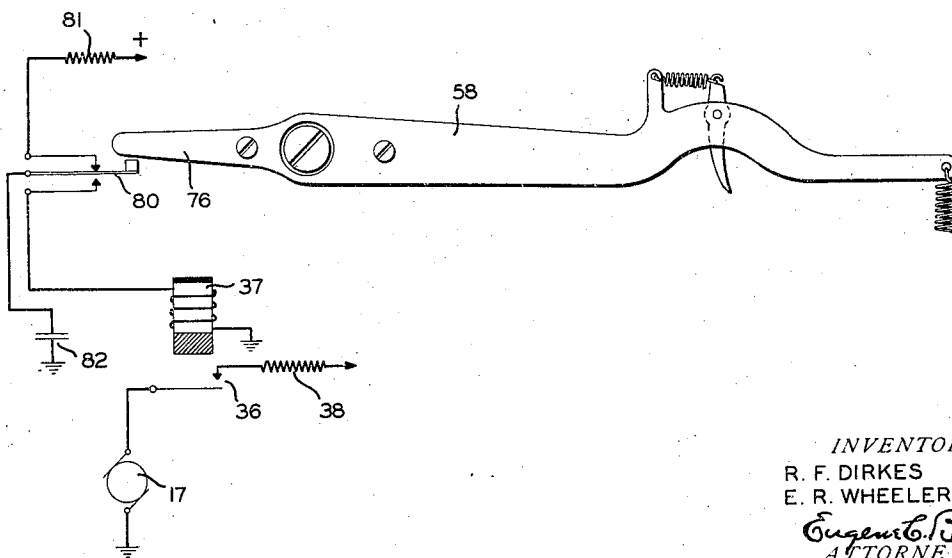

FIG. 5



INVENTORS  
R. F. DIRKES  
E. R. WHEELER  
*Eugene C. Brown*  
ATTORNEY

# UNITED STATES PATENT OFFICE

1,994,017

## TAPE CONTROL MECHANISM

Robert F. Dirkes, Jamaica, N. Y., and Evan R. Wheeler, Plainfield, N. J., assignors to The Western Union Telegraph Company, New York, N. Y., a corporation of New York

Application June 9, 1932, Serial No. 616,306

8 Claims. (Cl. 178-42)

This invention relates to telegraph printing and projecting systems in which information, such as stock quotations, printed upon a tape, is projected upon a screen for observation. More particularly the invention relates to means for controlling the feeding of the tape through the field of the projector.

In a prior patent of R. F. Dirkes, No. 1,684,309, granted September 11, 1928 and entitled "Method of and means for feeding tape and projecting it therefrom" there is shown a tape pulling mechanism in which the tape is drawn through the field of the projector by a motor started into operation whenever predetermined slack occurs in the tape between the printer and the projector, and which is stopped to arrest the movement of the tape whenever the surplus tape has been substantially eliminated. The motor circuit in the aforesaid patent is opened and closed by a contact, controlled by an auto-stop arm resting in a loop of the tape which is allowed to accumulate between the printer and the projector. This type of control is very effective since, due to the inertia of the motor armature, the starting and stopping of the motor is gradual and consequently a gradual acceleration and deceleration of the tape occurs upon each movement thereof, whereby the usual jerky movement incident to starting and stopping the tape is eliminated. Also, due to overthrow of the motor controlling contacts there is always a certain dwell between the starting and stopping of the tape, whereby several characters will be advanced into the field of the projector upon each movement of the tape, thereby eliminating the usual step-by-step movement of the characters across the screen should the printer operate at a slow rate.

The present invention is in the nature of an improvement upon the scheme proposed in said prior patent and has for one of its objects, to reduce still further the frequency of the starting and stopping of the tape in the field of the projector.

Another object is to remove the control of the starting and stopping of the motor from the tape lever and make it entirely independent thereof.

Another object of the invention is to control the period of operation of the tape puller entirely from the printer and in accordance with the periods of continuous operation thereof.

A still further object is to regulate the rate of movement of the tape through the field of the projector and correlate its speed to the speed of operation of the printer so as to effect a reduction

in the number of times the tape is started and stopped.

Other objects and advantages of the invention will appear hereinafter.

In the transmission of stock quotations, the quotations are perforated in a tape at the transmitting station and transmitted automatically over the ticker lines by means of standard forms of tape transmitters. If the market is active the perforating proceeds substantially continuously and the corresponding signals are transmitted at a uniform speed over the lines with but few interruptions. In a slow market, while there will be more frequent interruptions in the transmission, the signals would ordinarily be transmitted in groups, each group corresponding to a number of quotations. The rate of transmission of the signals of each group, however, will proceed at a uniform rate independent of the length of the group.

We take advantage of this particular character of the transmitted signals to control the operation of the tape pulling mechanism.

In accordance with our invention we start the movement of the tape when the first character of a string of quotations is received and maintain the movement thereof continuous as long as the successive characters are received without interruption. The movement of the tape ordinarily proceeds slowly at the start but if the period of transmission without interruption continues the rate of movement of the tape is increased so that an undue length of tape is never permitted to accumulate between the printer and the projector. Upon interruption of the transmission of character signals the movement of the tape is immediately arrested irrespective of the size of the loop of tape which has accumulated between the printer and the projector. However, the control of the speed of the tape is such as to prevent either the complete exhaustion of the loop or the accumulation of an unduly large loop, the loop thereby being maintained within narrow limits.

It will be obvious from the foregoing explanation that the stopping of the tape corresponds to each interruption in the transmission but as these interruptions occur between an appreciable number of quotations and since there are no interruptions in the tape movement except at such times, the actual number of times the tape is brought to rest is less than in systems heretofore employed wherein the tape puller is operated at a speed in excess of the maximum speed of the printer, thereby necessitating frequent starting

and stopping of the tape during continuous operation of the printer.

The invention will be more fully understood by reference to the accompanying drawings, in which:

Figure 1 is a front elevation of a tape pulling and control arrangement embodying the present invention as applied to a printer of the permutation code type;

Figure 2 is a side elevation of the tape pulling mechanism;

Figure 3 illustrates a modified form of motor contact controlling mechanism which may be employed;

Figure 4 illustrates the invention as applied to a ticker of the step-by-step type, and

Figure 5 shows a modification of the motor control contact operating mechanism applied to the printer shown in Figure 4.

Referring first to Figure 1, the tape T which is contained upon a reel 10 is fed through ticker or other printing telegraph apparatus, represented conveniently by the type wheel 11, platen 12 and feed rolls 13. The feed rollers serve to step the tape forward intermittently as printing of each character occurs.

Obviously any type of tape printer may be employed operated either by a uniform code such as the Baudott Code or by step-by-step signals. In the embodiment shown in Figures 1, 2 and 3 the printer is assumed to be of the start-stop type, the selecting and printing functions being controlled by a single revolution shaft 14. This printer may be of the form shown in United States Patent to Morton et al., No. 1,821,110 granted September 1, 1931.

The tape is drawn over a support 15 extending across the field of the projector, not shown, by means of a tape-puller indicated generally at 16, driven by an electric motor 17. The tape is re-wound upon a take-up reel 18.

The tape-puller is geared to operate at a maximum speed slightly greater than the maximum output of the printer and in order that the movement of the tape across the field of the projector will be smooth, a loop 19 of tape is allowed to form between the printer and the guide 15. The speed of movement of the tape across the guide is controlled by the size of the loop 19 but the starting and stopping of the tape is entirely independent of the loop, as will subsequently appear.

The tape-pulling mechanism includes a roller 21 fixed upon a shaft 22 driven through suitable reduction gearing, contained within a housing 23, by the electric motor 17. A roller 24 mounted upon a pivot arm 25 presses the tape against the feed roller 21, by means of the spiral spring 26. The take-up reel 18 is operated from the shaft 22 by a belt 27 extending round a pulley 28 fixed to the shaft 22 and a second pulley 29 loosely mounted upon shaft 31 of the reel 18. The shaft 31 is driven from the pulley 29 through a friction clutch 32. The tape passes from the guide 15 under an idler roller 33, thence between the rollers 21 and 24 and over a second idler roller 34 to the reel 18.

The circuit for the motor 17 extends from one side of the power line 35 through the contact and tongue 36 of a control relay 37 and thence through a speed regulating resistance 38 to the motor and back to the opposite side of the power line. The resistance 38 is arranged to be short-circuited through the pivoted lever 39, resting

upon the loop of tape 19 and its lower stop or contact 41.

The relay 37 is of the slow to release type and is energized during the reception of each character code signal through a pair of contacts 42 controlled by a cam 43 mounted upon the start-stop shaft 14 of the printer. In the normal rest position of the printer the cam 43, as shown in Figure 1, engages the lower end of a pivoted lever 44 thereby holding the contacts 42 open through a roller 45 carried by the upper end of the lever 44 contacting with the cam face of the upper spring of the contacts 42. Whenever a selection is received by the printer the cam 43 makes a revolution with the start-stop shaft, thereby releasing the lever 44 whereupon its upper end is pulled to the left by a spiral spring 46, allowing the contacts 42 to close and thereby completing the circuit for the slow-acting relay 37. The relay contacts 36 being thus closed, the motor circuit is completed and movement of the tape across the support 15 started.

The relay 37 is sufficiently slow acting so that it does not release between successive characters when the printer is operating at normal speed. Since the received signals are transmitted at a uniform rate and in groups of an appreciable number of characters, the motor 17 will remain in constant operation as long as the signals are being continuously received and the tape will move without interruption across the support 15. When an interruption occurs between transmission of successive groups of quotations the motor will immediately stop, arresting the movement of the tape. There are no interruptions in the tape movement, however, during the continuous reception of signals by virtue of the controlling of the motor speed through tape lever 39 in the following manner:

Assuming that loop 19 of tape to be sufficiently large, as shown, to cause the lever 39 to rest on its lower contact 41, the resistance 38 will be shunted out of the motor circuit and the motor will operate at maximum speed. As stated this speed is sufficient to draw the tape over the support slightly faster than the rate at which it is ejected by the printer, assuming the printer to be operating continuously. Consequently the loop 19 is slowly diminished until it lifts the lever 39 away from the contact 41, thereby including the resistance 38 in the motor circuit. The resistance 38 is adjusted so as to reduce the motor speed slightly below that required to keep pace with the printer. The loop 19 therefore again increases until the shunt around the resistance 38 is again closed. It will be evident, therefore, that the motor is alternately slowed down and speeded up as the printer continues to operate so as to maintain a loop of tape within substantially narrow limits but no interruptions occur in the movement of the tape except those occasioned by the actual prolonged stopping of the printer. The period of movement and rest of the tape therefore corresponds to the operating and idle periods of the printer and the speed of the tape approximates the rate of ejection thereof from the printer.

In Figure 3 we have shown the slow acting means in the form of a dash-pot 48 controlled from the cam 43. The contacts 49 in this case are directly in the motor circuit so that as the cam 43 revolves plunger 51 of the dash-pot is raised against the spring 52 thereby closing the contacts and completing the motor circuit. It will be understood that in the normal operation

of the printer the contacts 49 remain closed during successive revolutions of the cam shaft but should an interruption occur in the signals the plunger of the dash-pot will drop sufficiently to open the motor controlling contacts.

Thus it can be readily seen that dash-pot 48 in conjunction with contacts 49 acts mechanically as a slow acting relay and takes the place of the relay 37.

In Figure 4 we have shown the invention as applied to a self-winding ticker in which the type wheel 54 is stepped around into printing position by a variable number of transmitted impulses. The tape T is advanced over a platen 55 beneath the type wheel by a pair of knurled feed rollers 56 and 57. After the type wheel has been positioned, printing is effected by a lever 58 pivoted at 59 and having a downward extension 61 provided with a lug 62 adapted to engage beneath the platen 55 to raise the same against the type wheel. Upon each upward movement of the lever 58 a feed pawl 63 is advanced around the ratchet 64 and on the return stroke rotates the feed wheel 57 to advance the tape. The lever 58 is raised by a printing magnet 65 and lowered by a spiral spring 66.

In this embodiment a pair of motor control contacts 66 and 67 are mounted upon the frame of the printer and are arranged to be opened by an extension 68 of the plunger 69 of a dash-pot 71. The plunger 69 is normally urged in an upward direction by a spring 72 and is pulled downwardly by a latch 73 secured to the outer end of a lever 74 pivoted at 75. The lever 74 is connected to the extended end 76 of the printing lever 58 by a link 77. The latch 73 is held in engagement with the beveled end 68 of the plunger by means of a spring 70. It will be evident from the foregoing that upon each printing stroke of the lever 58 the plunger 69 is pulled downwardly permitting contact 67 to close.

In the operation of a ticker of this type the printing magnet 65 is energized by prolonged steady current following the stepping impulses. Under certain operating conditions, the transmission is such that this steady line current is continued for a considerable period. Therefore, during these periods the magnet 65 is continuously energized, holding the extension 76 of the lever 58 depressed. In order that the contacts 67 will not be held continuously closed during such periods so as to cause operation of the motor while the printer is idle, the latch 73 is provided with a cam surface 78 adapted to engage a pin 79 as the latch is pulled downwardly, thereby throwing the latch to the left out of engagement with the beveled extension 68 of the plunger. Consequently the plunger is free to return independently of the position of the lever 58.

In Figure 5 we have shown this same result obtained in a somewhat different manner. In this form with the printing lever 58 in its normal position, that is with the magnet 65 deenergized, the contact spring 80 rests against its upper contact completing a circuit from a source of potential through a resistance 81 to a condenser 82. When the printing impulse is received, the extension 76 of the lever 58 forces contact spring 80 to its lower contact, permitting the condenser to discharge through the slow to release relay 37, thereby maintaining the contacts 36 closed and completing the circuit to the motor 17 through the resistance 38. It is evident that regardless of how long the lever 58 may be held in operated position, only a single impulse will

flow through the relay windings 37. Therefore, if any interruptions occur in the continued operations of the printer, the relay 37 will be free to open its contacts and interrupt the motor circuit.

It will be obvious, of course, that various other ways will occur to those versed in the art for maintaining the motor in operation during active operating periods of the printer and that the invention may be applied to various other types of printers. If desired, in place of starting and stopping the motor any other form of tape control may be employed. We do not desire to be limited, therefore, to the particular details shown and described except as required by the terms of the appended claims.

What we claim is:

1. In combination, a printer adapted to eject a printed record therefrom, a cam shaft for said printer, a support, feeding means for moving said printed record across said support, means operated from said cam shaft for rendering said feeding means effective to so move the tape upon each operation of the printer and means for maintaining said feeding means continuously effective during the interval between the printing of successive characters received in substantially continuous succession.

2. In combination, a printer adapted to eject a printed record, a cam shaft therefor, a support, an electrically operated pulling device for advancing said printed record across said support, switch means for controlling the operation of said pulling device and means including said cam shaft for closing said switch means during nearly the full period of the selection and printing of each character.

3. In combination, a telegraph printer adapted to eject a printed record, a support, a pulling motor for feeding said tape over said support, an operating shaft for said printer and entirely mechanical means actuated by each revolution of said shaft for controlling the circuit of said pulling motor, said means serving to maintain said motor circuit closed between the printing of successive characters received in continuous succession.

4. In combination, a printer adapted to eject a printed record, a cam shaft for said printer, a support, a pulling mechanism for advancing said record over said support, a motor for said pulling mechanism, means responsive to the operation of said cam shaft incident to the printing of each character for closing said motor circuit, said means being slow acting whereby to maintain the motor circuit closed for a substantial period.

5. In combination, a printer adapted to eject a printed record, an operating shaft for said printer adapted to make a complete revolution for the printing of each character, a support, a pulling device for advancing said record over said support, and electrically controlled means for rendering said pulling device effective to so advance the record, a slow to release relay for completing a circuit to said electrically controlled means, and means for energizing said relay during nearly the complete revolution of said operating shaft.

6. In combination, a printer for producing a printed record, a cam shaft for the printer, a support, a pulling mechanism for advancing said record over said support, a motor for said pulling mechanism, a dash-pot controlled switch in circuit with said motor, and means including said cam shaft for mechanically actuating said

dash-pot in a circuit closing direction upon the printing of each character.

5 7. In combination, a printer adapted to produce a printed record, a support, a pulling mechanism for advancing said record over said support, electrically operated controlling means for said pulling mechanism, a slow to release relay for completing the circuit to said electrically operated controlling means, means for charging a  
10 condenser during one part of each printing cycle, and means for discharging said condenser through said relay during another part of the printing cycle, the discharge current of said condenser being the sole energizing force for said  
15 relay.

8. In combination, a printer adapted to eject tape therefrom, a cam shaft for said printer, a support, a pulling means for advancing said tape over said support, a motor for operating said pulling means, the circuit to said motor being  
5 made and broken by entirely mechanical means actuated by the cam shaft of said printer to start and stop the movement of the tape independent of any loop therein, and means for varying the  
10 speed of said motor in accordance with the rate of ejection of tape from the printer.

ROBERT F. DIRKES.  
EVAN R. WHEELER.