

(No Model.)

3 Sheets—Sheet 1.

E. A. TRAPP.  
DUMPING CAR.

No. 525,727.

Patented Sept. 11, 1894.

Fig. 1.

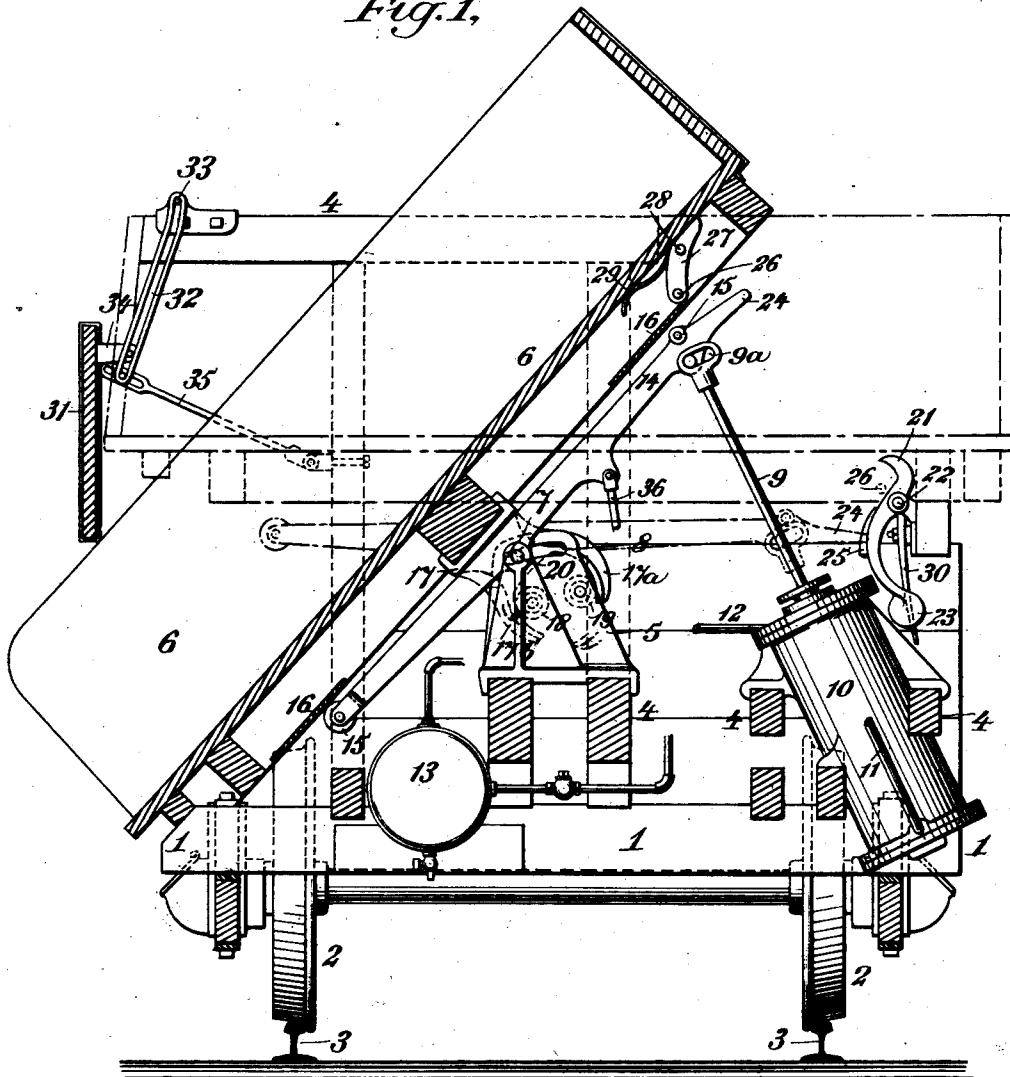

Witnesses:-

*O. N. Hayward*  
*E. E. Garhart*

Inventor:-

*Edward A. Trapp*  
*by A. Parker Smith*  
*his Atty.*

(No Model.)

3 Sheets—Sheet 2.

E. A. TRAPP.  
DUMPING CAR.

No. 525,727.

Patented Sept. 11, 1894.

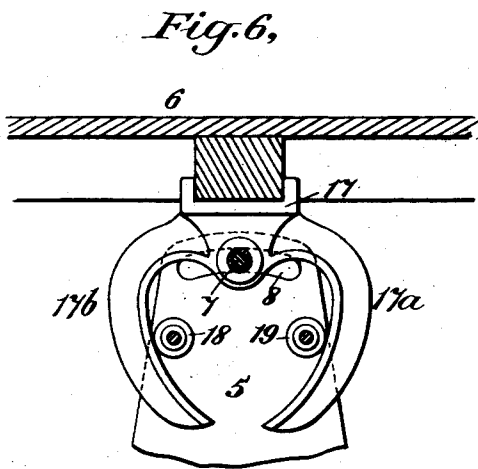
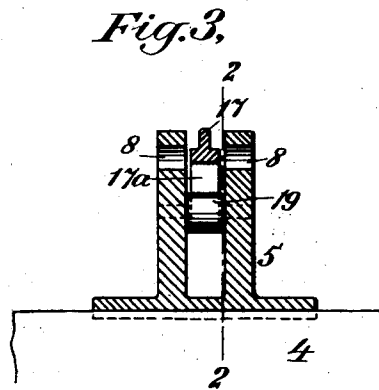
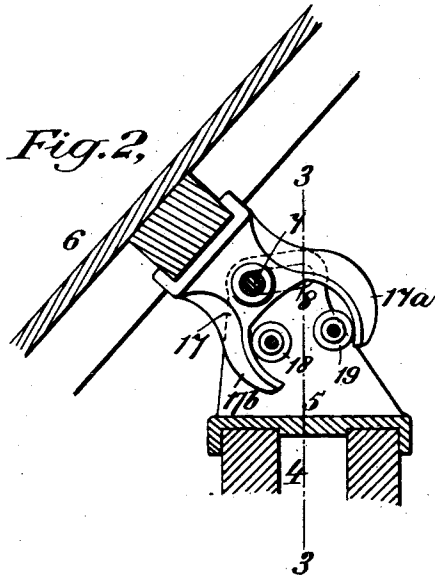

*Fig. 4,*

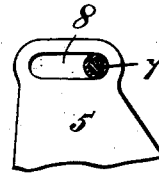

*Fig. 5,*

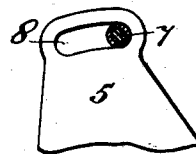

Witnesses:

*B. H. Hayward*  
*E. E. Gerhart*

*Edward A. Trapp, Inventor:*  
*by A. Parkhurst*  
*his Atty.*

(No Model.)

3 Sheets—Sheet 3.

E. A. TRAPP.  
DUMPING CAR.

No. 525,727.

Patented Sept. 11, 1894.

*Fig. 7.*

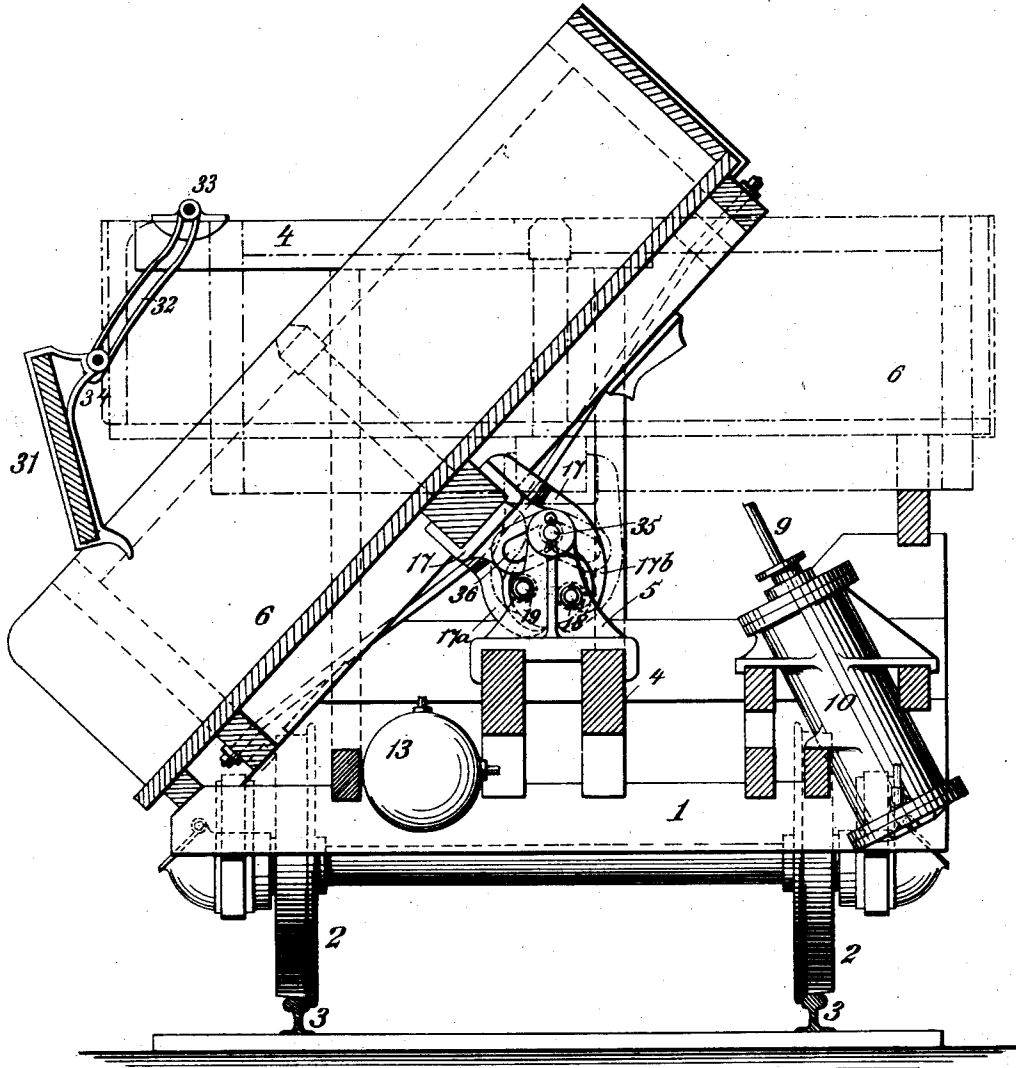

*Witnesses:-*

*O. H. Raymond*  
*E. E. Gerhart*

*Inventor:-*

*Edward A. Trapp*  
*J. P. Parkhurst*  
*Atty.*

# UNITED STATES PATENT OFFICE.

EDWARD A. TRAPP, OF NEW YORK, N. Y.

## DUMPING-CAR.

SPECIFICATION forming part of Letters Patent No. 525,727, dated September 11, 1894.

Application filed February 27, 1894. Serial No. 501,734. (No model.)

*To all whom it may concern:*

Be it known that I, EDWARD A. TRAPP, a citizen of the United States, residing at New York, in the county of New York and State of New York, have invented certain new and useful Improvements in Dumping-Cars; and I do hereby declare the following to be a full, clear, and exact description of the invention, such as will enable others skilled in the art to which it appertains to make and use the same.

My invention relates to dumping cars and is more specifically intended to be applied to cars which are dumped by the application of power either of compressed air or other agent under control of the engineer upon the locomotive pulling the train.

The invention here described is an improvement upon the construction disclosed in United States patents, No. 493,317, granted to me March 14, 1893; No. 513,446, granted to me January 23, 1894, and No. 513,447, of the same date.

In constructing dumping cars which may be depended upon to completely free themselves from their contents when dumped it is necessary to tip the car to such an angle of inclination as will cause every particle of its contents to overcome the adhesion to the car floor and slip out on to the dump. As the car body must, of course, overhang the wheels of the truck, it is necessary, where the car is swung about a pivot rigid upon the supporting frame, to build said supporting frame at a considerable height in order to obtain the necessary inclination in dumping. The building of a high frame increases the cost of construction, the length of the working parts of the tipping apparatus and renders the car of unstable equilibrium on account of the elevation of its center of gravity, while it also, in many cases, increases the labor of loading it.

To avoid the above mentioned difficulties and disadvantages and at the same time secure an acute angle of dumping which shall insure the complete emptying of the car, I have hit upon the idea of securing the swinging car body to a supporting frame by a pin and slot connection which shall allow of considerable lateral motion of the car body when being dumped. In this way the center of rotation of the car body being shifted toward

the wheels upon that side where the car is dumping the base of the right-angle triangle, of which the floor represents the hypotenuse, is considerably shortened and consequently the desired angle of inclination can be obtained without unduly increasing the length of the perpendicular of said triangle.

The preferred form of apparatus for carrying out and embodying my idea is illustrated in the accompanying two sheets of drawings, in which—

Figure 1, is an end view and partial section of a car embodying my invention, the car being shown in dumping position in full lines and in carrying position in dotted lines. Fig. 2, is a detail of the pin and slot connection, which is the essence of my invention, a section being taken on line 2, 2, of Fig. 3. Fig. 3, is another view of the slotted standard, section being taken on line 3, 3, of Fig. 2. Fig. 4, is a detail showing a horizontal slot. Fig. 5, is a detail showing a curved slot. Fig. 6, is a detail showing the form of curved jaws for a mechanism calculated to dump the car on either side. Fig. 7, illustrates a modification in which the pin is on the truck frame and the slot is in the casting attached to the car body.

Throughout the drawings like reference figures refer to like parts.

1, is the car truck resting on the wheels 2, which run upon the rails 3, in the usual manner. 4, is a supporting frame resting on said car truck and rigid therewith.

5, is a slotted standard preferably made double in form, as shown in Fig. 3, which rests upon the supporting frame approximately in the longitudinal center of the car. Of course, there are two or more of these standards 5, supporting the ends and, if desired, the intermediate points of the car body.

6, is the swinging car body which moves or oscillates upon the supporting frame by virtue of the connection afforded by the pin 7, which is rigid with the car body and the co-acting slot 8, which is formed in the standard 5. The pin 7, is set in the casting 17, which has the curved jaws 17<sup>b</sup>, and 17<sup>a</sup>.

The dumping of the car is effected through mechanism operating upon the plan described and claimed in my Patents Nos. 513,446 and 513,447 above referred to and the parts of

which shown may be briefly referred to as follows:

9, is a piston rod operated by the piston in the compressed air cylinder 10, which has connections 11, and 12, to the train pipe and the auxiliary tank 13, all in the manner well understood or described in my patents above referred to.

14, is the dumping lever which is pivoted to the supporting frame at some point as 20, intermediate of its extremities. This dumping lever has friction rollers 15, on its extremities which bear upon the friction plates 16, on the bottom of the car body and thereby effectuate the tipping of said car body when the lever is oscillated by means of the piston rod 9. The connection of said piston with the lever 14, is by means of the pin and slotted head 9<sup>a</sup>. This action is rendered possible notwithstanding the fact that the car body has a shifting pivot while the lever has a fixed fulcrum by means of the said friction rollers 15, and their co-acting plates 16.

As above mentioned the casting 17, which is rigid with the car body 6, has curved jaws 17<sup>a</sup>, and 17<sup>b</sup>, which as the car body tips move upon the friction rollers 19, and 18, respectively, which are mounted in the standard 5, and this mechanism, together with the pin and slot 7, and 8, control the character of motion of the swinging car body 6.

When the car body is in a horizontal position ready to carry the load it is held down by the dog 21, which is pivoted to the supporting frame by the pin 22, and normally held in the position shown by the weight 23, but which, when the dumping lever 14, is drawn down into the position shown in dotted lines, is forced by reason of the end 24, of said lever bearing against the raised piece 25, on said dog, into such position as causes it to overhang the pin 26, upon the car body and hold said car body in a horizontal position until the dumping lever is forced up preparatory to dumping the car. All of this mechanism, including the lever 30 for tripping the locking mechanism by hand, is fully described and claimed in my Patent No. 513,447 above mentioned; but I have found it necessary in view of the independent motions of the dumping lever 14, and car body to provide a spring latch for this locking dog which is represented by the pin 26, mounted in the oscillating piece 27, pivoted to the car body at 28, and normally forced out by the spring 29. If, therefore, for any reason the dumping lever 14, should come down and lock the dog 21, over in its engaging position before the car body had swung far enough to place the pin 26, under the dog 21, the spring latch arrangement, above described, will allow this pin 26, to slip over the end of the dog and lock.

As also described in my Patent No. 513,447, I employ a swinging door 31, for the car which by means of the pin on the lugs 34, sliding in the slotted link 32, which is pivoted to the

supporting frame 4, at 33,—is formed to travel with the car body during the initial portion of its dumping motion. As a considerable portion of the said dumping motion is a lateral motion by reason of the pin and slot connection of the car body to the supporting frame, it is evident that this lateral motion must be allowed for in the door 31, also, and to accomplish this I pivot the link 32, at the point 33, and give it a slotted connection at its lower end by means of the slotted link 35. Of course a chain or other flexible connection might be substituted for slotted link 35.

It is evident that the slot 8, in the standard 5, may either be straight or curved and these two variations are shown in Figs. 4, and 5; and it is also evident that if straight, the slot may be so disposed that its end toward the side where the car is dumping may be in a lower horizontal plane than that in which the pin rests when the car body is in a condition of rest, all as shown in Fig. 2; or, that both ends of the slot may be in the same horizontal plane as in Fig. 4.

When the car dumps only to one side the jaws 17<sup>a</sup>, and 17<sup>b</sup>, are not exactly similar but are so shaped as to economize material and give the desired characteristics to the dumping and return motions. It may be desired, however, to build a car which would dump on either side and in that case the friction rollers 18, and 19, and their co-operating jaws 17<sup>a</sup>, and 17<sup>b</sup>, would be symmetrically arranged with reference to the center line, as shown in Fig. 6, and the slot 8, would be extended on either side of said center line, as shown in said figure. The rod 36, broken off, indicates the connection for automatically operating the air valve.

In the modification shown in Fig. 7, the pin 35, is mounted in the standard 5, while the slot 36, is in the casting 17, attached to the car body. It is evident that the pin and slot 35, and 36, will co-operate as do the pin and slot 7, and 8, in the first described form of invention.

The operation of my invention, so far as has not already been described is as follows: The car body 6, being in the horizontal position shown in the dotted lines, the power is applied by compressed air or other fluid, to drive up the piston rod 9. This forces up the end 24, of the dumping lever 14, until the friction roller upon that end comes in contact with the plate 16, on the bottom of the car body. This motion is sufficient to unlock the dog 21, which drops into the position shown in Fig. 1, and thereby releases the pin 26, of the latch upon the car body. Further motion of the piston and dumping lever 16, begins to tip the car body itself. As the car body begins to tip it takes on a lateral motion, the pin 7, moving in the slot 8, as soon as the curved jaw 17<sup>b</sup>, begins to bear against the friction roller 18. The further tipping motion results in further lateral or horizontal motion at the pin and slot connection according to the character of the curves of the jaw

17<sup>b</sup>. When the piston has reached the end of its stroke the pin 7, is in the outermost end of the slot 8. The door 31, has followed the tipping and lateral or horizontal motion of the car body 6, by virtue of its flexible support in the pivoted link 32, until it has reached the lower end of said link when its further motion has ceased and the contents of the car have been discharged beneath it. A reversal of the power apparatus draws the car back to the horizontal position giving it a combined tipping and lateral or horizontal motion, determined by the curves of the jaw 17<sup>a</sup>, which now comes into play against the friction roller 19. When back in its horizontal position, the car body is locked by the dog 21, in the manner previously described.

The advantages of this invention are as above stated, that by shifting the pivotal point of the car body toward the side as it is dumped, a much greater angle of inclination is obtained than would be the case if the pivot were rigid, in view of the action of the car truck wheels in limiting the motion of the outer end of the car body. At the same time if the slot 8, is given an inclination, as shown in Figs. 1, 2, and 5, the slight vertical component of motion of the pin in said slot helps to, in a measure, relieve the power apparatus of the work of dumping. The tendency evidently is for the car body to slide down this inclined plane and, to a certain extent, dump itself. The added work of dragging the car body up the incline after dumping is of comparatively little importance because the car body is then empty and light. It is evident that by properly laying out the inclination of the slot 8, and the curves of the jaws 17<sup>a</sup>, and 17<sup>b</sup>, the work of dumping the car body could be exactly equalized, for a load of a given weight, with the work of bringing it back to its normal position, and thereby any waste of air pressure or other power employed would be avoided.

Of course various changes could be made in the construction of the slotted standard and the pin connection without departing from the spirit of my invention. Similar reversals or variations of mechanism, which will be obvious to the skilled mechanic, could be made, but all such I desire to include in my invention. It is obvious also that this invention would apply equally well to a car to be dumped by hand or by any other power than that illustrated, but the same advantages of construction and of equalization of effort in dumping and retracting the car body would obtain.

Having, therefore, described my invention, what I claim as new, and desire to protect by Letters Patent, is—

1. In a dumping car, the combination of the truck and supporting frame thereon, the swinging car body, the pin and slot connection between said supporting frame and said swinging car body, one or more pins mounted on one of the two last mentioned elements of

the combination, to wit, the supporting frame or the swinging car body, and curved jaws mounted on the other of said two last mentioned elements and embracing the above described pin or pins, said pin or pins and co-operating jaws, together with the pin and slot connection, positively controlling the motion of the car body in dumping, substantially as described.

2. In a dumping car, the combination of the truck and supporting frame thereon, the swinging car body, the pin and slot connection between said supporting frame and said swinging car body, one or more pins mounted on one of the two last mentioned elements of the combination, to wit, the supporting frame or the swinging car body, and curved jaws mounted on the other of said two last mentioned elements and embracing the above described pin or pins; said pin or pins and co-operating jaws, together with the pin and slot connection, positively controlling the motion of the car body in dumping, together with automatic means for producing the dumping of the car body, substantially as described.

3. In a dumping car the combination of the truck and supporting frame thereon, the slotted standard on said frame, the pin which is mounted in a casting rigid on said car body, which pin moves in the slot in said standard, the pins mounted in said standard, and curved jaws on said casting which engage said last mentioned pins and which in connection with the first mentioned pin and the slot in the standard control the motion of the car body as it dumps, together with means for moving said car body about these pins, substantially as described.

4. In a dumping car the combination of the truck and supporting frame thereon, the slotted standard on said frame, the pin which is mounted in a casting rigid on said car body, which pin moves in the slot in said standard, the pins mounted in said standard, and curved jaws on said casting which engage said last mentioned pins and which in connection with the first mentioned pin and the slot in the standard control the motion of the car body as it dumps, together with mechanism operated by compressed air for moving said car body about these pins, substantially as described.

5. In a dumping car the combination of the truck and supporting frame thereon, the slotted standard on said frame, the pin which is mounted in a casting rigid on said car body, which pin moves in the slot in said standard, the pins mounted in said standard, and curved jaws on said casting which engage said last mentioned pins and which in connection with the first mentioned pin and the slot in the standard control the motion of the car body as it dumps, friction rollers on the pins, together with means for moving said car body about these pins, substantially as described.

6. In a dumping car the combination of the

truck and supporting frame thereon, the swinging car body and the pin and slot connection by which said car body is pivoted to said frame and given freedom for lateral motion thereon, the door for said car, the links 5 pivoted to the supporting frame and supporting said door, and the slotted connection from the frame to the lower portion of said links whereby they are permitted to accommodate 10 themselves to the lateral motion of the car body, substantially as described.

7. In a dumping car the combination of the truck and the supporting frame thereon, the

swinging car body pivoted thereto, the dumping lever, and means for operating the same, the latch for holding the car body down to the supporting frame which latch is locked by the dumping lever, and the spring catch for said latch mounted on said car body, substantially as described.

In testimony whereof I affix my signature in presence of two witnesses.

EDWARD A. TRAPP.

Witnesses:

A. PARKER SMITH,  
W. DE VEAN TUNSTALL.