

(19) World Intellectual Property Organization
International Bureau



(43) International Publication Date
21 March 2002 (21.03.2002)

PCT

(10) International Publication Number
WO 02/22032 A1

(51) International Patent Classification⁷: **A61B 18/18**

Menlo Park, CA 94025 (US). **HUANG, Alexander, L.**; 903
Arnold Way, Menlo Park, CA 94025 (US).

(21) International Application Number: PCT/US01/28707

(74) Agents: **HESLIN, James, M.** et al.; Townsend and
Townsend and Crew LLP, Two Embarcadero Center, 8th
Floor, San Francisco, CA 94111-3834 (US).

(22) International Filing Date:
14 September 2001 (14.09.2001)

(25) Filing Language: English

(81) Designated States (*national*): AU, CA, JP, KR.

(26) Publication Language: English

(84) Designated States (*regional*): European patent (AT, BE,
CH, CY, DE, DK, ES, FI, FR, GB, GR, IE, IT, LU, MC,
NL, PT, SE, TR).

(30) Priority Data:
09/663,048 15 September 2000 (15.09.2000) US

Published:
— with international search report
— before the expiration of the time limit for amending the
claims and to be republished in the event of receipt of
amendments

(71) Applicant: **RADIOTHERAPEUTICS CORPORA-
TION** [US/US]; 1308 Borregas Avenue, Sunnyvale, CA
94089 (US).

(72) Inventors: **BEHL, Robert, S.**; 361 Tioga Court, Palo Alto,
CA 94036 (US). **GROSSER, Morton**; 1016 Lemon St.,

For two-letter codes and other abbreviations, refer to the "Guid-
ance Notes on Codes and Abbreviations" appearing at the begin-
ning of each regular issue of the PCT Gazette.

(54) Title: METHODS AND SYSTEMS FOR FOCUSED BIPOLAR TISSUE ABLATION

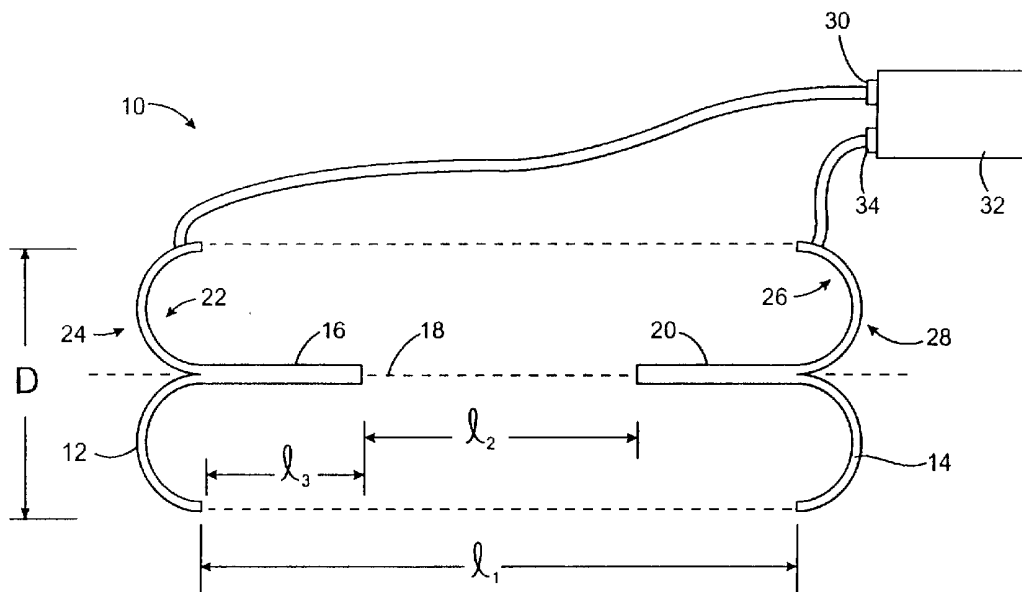

(57) Abstract: Large tissue regions are treated using pairs of electrode arrays (12, 14). The electrode arrays may be concave and disposed in tissue so that their concave portions are opposed to each other. Axial conductors (16) may be provided extending from the arrays and toward each other in order to increase the heating of tissues lying along the axis between the deployed electrode arrays. By properly spacing the electrode arrays apart and selecting the diameters of the arrays, desired volumes of tissue may be treated, typically with a bipolar, radiofrequency current.

WO 02/22032 A1

METHODS AND SYSTEMS FOR FOCUSED BIPOLAR TISSUE ABLATION

BACKGROUND OF THE INVENTION

5 1. Field of the Invention

The present invention relates generally to the structure and use of radiofrequency electrosurgical apparatus for the treatment of solid tissue. More particularly, the present invention relates to an electrosurgical system having pairs of electrode arrays which are deployed to treat large volumes of tissue, particularly for the
10 treatment of tumors in the liver and other tissues and organs.

The delivery of radiofrequency energy to treatment regions within solid tissue is known for a variety of purposes. Of particular interest to the present invention, radiofrequency energy may be delivered to diseased regions in target tissue for the purpose of causing tissue necrosis. For example, the liver is a common depository for
15 metastases of many primary cancers, such as cancers of the stomach, bowel, pancreas, kidney, and lung. Electrosurgical probes for deploying multiple electrodes have been designed for the treatment and necrosis of tumors in the liver and other solid tissues. See, for example, the LeVeen™ Needle Electrode available from RadioTherapeutics Corporation which is constructed generally in accord with published PCT application
20 WO 98/52480.

The probes described in WO 98/52480 comprise a number of independent wire electrodes which are extended into tissue from the distal end of a cannula. The wire electrodes may then be energized in a monopolar or bipolar fashion to heat and necrose tissue within a defined generally spherical volumetric region of target tissue. In order to
25 assure that the target tissue is adequately treated and to limit damage to adjacent healthy tissues, it is desirable that the array formed by the wire electrodes within the tissue be precisely and uniformly defined.

Despite the significant success that has accompanied use of the LeVeen™ Needle Electrode in treating solid tissue tumors, the ability to treat particular types of
30 tumors has been somewhat limited. For example, the ability to produce very large tissue lesions, for example lesions having volumes greater than 30-35 cm³, has been problematic. In addition, such larger tumors tend to be less spheroidal in shape than

smaller tumors. Since the LeVeen™ Needle Electrode produces generally spheroidal lesions, the ability to treat larger, non-spheroidal tumors can be limited. Additionally, the ability to treat highly vascularized tissues and/or tissue near a large blood vessel has also been limited. In the latter cases, heat being introduced by the electrode can be rapidly
5 carried away by circulating blood, making uniform heating and control of temperature in the vascularized tissues difficult. Uniform heating and temperature control of the tissue being treated is, of course, one prerequisite to obtaining homogenous lesions in and around the tumors.

The ability to provide uniform heating and the creation of homogenous
10 tissue lesions is particularly difficult with bipolar devices. The two bipolar electrodes may be placed in regions with quite different perfusion characteristics, and the heating around each pole can be quite different. That is, one pole may be located adjacent to a large blood vessel, while the other pole may be located adjacent to tissue which is less perfused. Thus, the pole located in the less perfused tissue will heat the tissue
15 immediately surrounding the electrode much more rapidly than the tissue surrounding the opposite polar electrode is heated. In such circumstances, the tissue surrounding one pole may be preferentially heated and necrosed, while the tissue surrounding the other pole will neither be heated nor necrosed sufficiently.

For all these reasons, it would be desirable to provide improved
20 electrosurgical methods and systems for treating tumors in the liver and other body organs. It would be particularly desirable if the methods and systems could produce relatively large lesions (regions of necrosed tissue) within the solid tissue, preferably being capable of producing lesions having volumes greater than $30\text{-}35\text{ cm}^3$, more preferably greater than 70 cm^3 , and even more preferably greater than 150 cm^3 , or larger.
25 In addition, it would be desirable to provide methods and systems which can uniformly produce tissue lesions in highly vascularized tissues, such as the liver, and even more particularly in tissues which are unevenly perfused, such as tissues which are near major blood vessels, in such organs. It would be still further desirable to provide methods and systems which can produce tissue lesions having a variety of geometries, such as ovoid
30 and cylindrical, rather than just spheroidal. At least some of these objectives will be met by the invention of the present application.

2. Description of the Background Art

U.S. Patent Nos. 5,827,276; 5,855,576; and 5,868,740 to LeVeen and German Patent Publication No. 2124684 to Stadelmayr describe devices for deploying pairs of axially spaced-apart electrode arrays. U.S. Patent Nos. 6,090,105; 6,071,280; 5,928,229; 5,913,855; 5,863,290; 5,672,174; and 5,672,173, describe multiple electrode devices having coaxial electrode structures including a primary antenna and at least one curved secondary antenna that deploys from the primary antenna. See, also U.S. Patent No. 5,611,803 and WO 99/32041.

SUMMARY OF THE INVENTION

The present invention provides improved methods, apparatus, and kits for performing electrosurgical treatment of tissues and in particular for performing radiofrequency tissue necrosis for the treatment of tumors and diseased tissues. The methods, apparatus, and kits are particularly useful for creating large volume tissue lesions, such as those having volumes above 30 cm³, often above 70 cm³, and sometimes above 150 cm³, or larger. In addition to being able to form relatively large volume tissue lesions, the methods, apparatus, and kits of the present invention are capable of producing highly uniform lesions where tissue necrosis is induced substantially uniformly through the entire treated region. Moreover, the present invention produces lesions having well-defined peripheries, typically ovoid or cylindrical, so that targeted tissue having different (non-spherical) geometries) may be necrosed with only minimum damage to adjacent healthy tissues.

In a first aspect of the present invention, probes for deploying electrode arrays comprise a shaft having a distal end and proximal end. A first array of electrodes is mounted on the shaft and is constructed or adapted to shift between a retracted configuration, typically within the shaft, and deployed configuration. The deployed configuration of the first electrode array will have a concave face, typically comprising a plurality of curved electrodes, more typically comprising at least three curved electrodes which evert when deployed from the shaft so that the electrodes each extend generally axially from the shaft, turn radially outward, and preferably turn around so that the tips of the electrodes are turned backwardly relative to their initial direction. In the most preferred embodiments, the electrode array will turn substantially completely, i.e., at or close to 180°, from the initial axial direction. The probe further includes a second electrode array having electrodes mounted on the shaft at a location spaced-apart

proximally from the first array of electrodes. The electrodes of the second array are also capable of shifting between a retracted configuration and a deployed, where the deployed array typically comprises a plurality of everting electrodes, generally as described above. The first and second arrays, when deployed, are arranged so that the concave faces are
5 opposed to each other on opposite sides of a treatment region.

In various preferred embodiments of the apparatus of the present invention, the probe may further include a self-penetrating tip, usually at the distal end of the shaft. The self-penetrating tip can take any conventional form, such as a sharpened tip, an electrosurgical tip (one adapted to penetrate tissue when connected to an
10 electrosurgical power supply operating in a cutting mode), and the like. Alternatively, the probes may be introduced through or by exchange with a conventional cannula and stylet assembly as described generally in U.S. Patent No. 5,827,276, the full disclosure of which is incorporated herein by reference.

The first and second electrode arrays will be mechanically coupled to the
15 shaft to permit their deployment relative to the shaft. Usually, one electrode array will be mounted to extend in a distal direction and to evert from the shaft while the second array will be mounted to advance in a proximal direction relative to the shaft and to evert therefrom. Usually, the individual electrodes of each electrode array will be received within one or more cavities or lumens within the shaft so that the electrodes may be fully
20 retracted into the shaft for introduction of the probe into tissue and removal of the probe from tissue. Operation of the two arrays may be coupled so that said arrays deploy simultaneously. More usually, however, the arrays will be separately deployable.

The first and second electrode arrays will each be connected or coupled to deployment mechanism(s) for advancing the electrodes relative to the shaft to achieve the
25 desired everted deployment. Usually, the deployment mechanisms will comprise a first rod connected to the first electrode array and slidably disposed in or on the shaft and a second rod or tube connected to the second electrode array and slidably disposed in or on the shaft. In this way, distal advancement of the first rod or tube relative to the shaft causes the first electrode array to extend distally and evert radially outwardly relative to
30 the shaft. Likewise, proximal retraction of the second rod relative to the shaft causes the second electrode array to draw proximally and evert radially outwardly from the shaft. Operation of the first and second rods or tubes may be coupled so that the user need perform only one deployment action using the probe. Usually, however, actuation of the two rods will not be coupled so that deployment of the two electrode arrays may be

effected entirely separately. In particular embodiments, the first rod may be mounted coaxially within a central lumen or passage of a second tube to provide for a more compact design.

In a first exemplary embodiment, the first and second rods are mounted
5 coaxially and threaded drive pins are mounted in a handle assembly in order to effect simultaneous advancement and retraction of the first and second rods. In a second exemplary embodiment, the first and second rods are mounted in parallel and a rack and pinion assembly is provided in a handle to effect simultaneous advancement and retraction of the rods. In a third exemplary embodiment, the distal and proximal arrays
10 may be separately advanced, with one array being initially deployed and the second array being separately deployed, usually after the first array is satisfactorily located. Optionally, the electrode deployment device embodiments which permit separate array deployment could be used with only a single array, usually but not necessarily the distal array. While the distal array will normally be deployed first, there is no reason why the
15 proximal array could not be deployed first, with or without subsequent deployment of the distal array. When only one array is deployed, the device could be used in a monopolar fashion with the deployed array being coupled to one pole of the power supply and a second, dispersive electrode (typically placed on an exterior body surface) being coupled to the other pole of the power supply. In the illustration of the third embodiment, the
20 distal array is deployed by advancing a rod which extends axially through the length of the device, typically by depressing a knob at the proximal end of the device. The proximal array, in contrast, is separately deployed by rotating a threaded sleeve in the device, typically using the same knob which is used to advance the distal array. Optionally, a marker is provided on the handle so that the deployment of the proximal
25 and/or distal array can be visually determined.

The first and second electrode arrays will typically comprise a plurality of

U.S. Patent No. 6,050,992, the full disclosure of which is incorporated herein by reference.

Once deployed, the electrode arrays will span a planar area which is disposed generally transverse to the axis of the shaft. The planar area which is spanned
5 will be generally circular, typically having an area in the range from 3 cm² to 20 cm² (when the electrodes are fully deployed), often in the range from 3 cm² to 15 cm², and preferably in the range from 6 cm² to 13 cm². The areas of the first and second electrode arrays will usually be approximately equal, though that is not necessarily the case at all times. In some instances, it may be desirable to use electrode arrays having differing
10 diameters and planar areas in order to produce lesions having different geometries. It will be appreciated that spaced-apart, axially aligned electrode arrays having circular peripheries with identical diameters will produce generally cylindrical lesions, while arrays having different diameters will produce lesions having conical sections.

Preferably, the first and second electrode arrays will be spaced-apart along
15 an axial line therebetween, usually through the shaft. Preferably, the arrays are spaced-apart by distance in the range from 2 cm to 10 cm, usually from 3 cm to 7 cm, and preferably from 4 cm to 6 cm.

The resulting volumes of necrosed tissue will generally be larger than those achievable with a single array device, such as the prior LeVein™ Needle Electrode
20 discussed above. The treatment volumes achievable with the present invention may be at least 30 cm³ or larger, often being 70 cm³ or larger, sometimes being 150 cm³ or larger, and typically being in the range from 50 cm³ to 70 cm³.

In other preferred embodiments of the apparatus of the present invention, the first and second electrode arrays will be electrically isolated from each other in order
25 to permit bipolar energization, i.e., to allow each electrode array to be separately connected as individual poles to an electrosurgical, radiofrequency, or other power supply. Such embodiments will typically include separate connectors for each of the electrode arrays in order to permit bipolar connection and operation. Of course, such separately connectable electrode arrays can also be operated individually in combination
30 with a separate dispersive electrode, either externally mounted or internally mounted, as described for example, in copending application no. 09/_____ (attorney docket no. 16807-002300), the full disclosure of which is incorporated herein by reference. In other embodiments, the first and second electrode arrays may be electrically

coupled to permit common monopolar operation, although such monopolar operation will generally be less desirable. The first and second electrode arrays may be coupled internally, i.e., within the electrode deployment device itself, or externally, e.g., in the power supply and/or in the cable(s) connecting the electrode deployment device to the power supply.

In still other preferred embodiments, at least the first electrode array will include a first axial conductor extending proximally along the shaft from the first electrode array. The first axial conductor will be electrically coupled to the first electrode array so that they will operate at the same electrical potential. Usually, the second electrode array will also include an electrically coupled axial conductor which extends distally along the probe shaft. The first and second axial conductors will thus be opposed (as are the first and second electrode arrays). A gap will remain between the termini of the axial conductors to maintain electrical isolation between the first and second electrode arrays. Usually, the gap will be in the range from 0.5 cm to 5 cm, preferably from 1 cm to 3 cm. Typically, arrays having smaller diameters will require less spacing in order to maintain isolation, thus requiring smaller gaps. At least the first axial conductor will preferably extend axially in the proximal direction beyond the tips of the electrodes of the first array. Usually, if a second axial conductor is employed, its tip will extend axially in a distal direction beyond the tips of the electrodes of the array. Thus, in an exemplary embodiment, the tips of both axial conductors will be closer to each other than the tips of the electrodes in the respective electrode arrays.

In another aspect of the present invention, methods for treating a treatment region in tissue comprise deploying a first electrode array in tissue on one side of the treatment region. A second electrode array is deployed in tissue along an axis with the first array and on the other side of the treatment region. Both the first and second electrode arrays have concave sides and convex sides, and a concave side of the first array faces a concave side of the second array when the electrodes are fully deployed. After deploying the electrodes, an electrical current, usually a bipolar radiofrequency current, is applied from the first and second electrode arrays through the intervening tissue.

Usually, deploying the first electrode array comprises introducing a first probe through tissue to a location on one side of the treatment region and advancing a first plurality of at least three electrodes from the probe in an evert pattern. The second electrode array is deployed similarly by advancing a second plurality of at least three electrodes from the probe in an evert pattern at a location on the other side

(typically opposite) of the treatment region. In the exemplary embodiments, the second electrode array is deployed from the same probe as was the first electrode array.

Alternatively, the second electrode array may be deployed from a second probe through tissue to the location on the other side of the treatment region, e.g., the side opposite to
5 the first electrode array.

The methods of the present invention are useful for treating a wide variety of tissues, particularly liver, lung, kidney, pancreas, stomach, spleen, uterus, and the like. Usually, the treatment region is a tumor or other diseased region and the treatment regions are imaged and identified using conventional techniques capable of elucidating a
10 target tissue, such as ultrasonic scanning, magnetic resonance imaging (MRI), computer-assisted tomography (CT), fluoroscopy, nuclear scanning (using radiolabeled tumor-specific probes), and the like.

Tissue necrosis is preferably achieved by applying radiofrequency current in an amount and for a time sufficient to thermally destroy the tissue. Usually, the
15 electrical current is applied at a frequency in the range from 300 kHz to 1.2 MHz. The current is applied at a power level selected to achieve the ablation, typically being in the range from 20W to 300W, usually from 50W to 200W. In the exemplary embodiments, the electrical current is supplied from a radiofrequency power supply in a bipolar manner where the first and second electrode arrays are attached to opposite poles of the power
20 supply.

The methods of the present invention will preferably employ first and second electrode arrays having the dimensions set forth above with respect to the probes of the present invention and will preferably produce lesions having the volumes defined by probes, as set forth above.

Preferably, the methods will employ a first electrode array having a first axial conductor extending at least part of the way toward the second electrode array along an axis therebetween. The first axial conductor will be electrically coupled to the first electrode array and will terminate at a point located axially beyond the termination points of the electrode wires in the first electrode array, typically by a distance in the range from
25 5 mm to 10 mm. Such extension of the first axial conductor axially beyond the first electrode array, places the conductor closer to the second electrode array and optional second axial conductor. Thus, a preferred central electrical conduction path is provided between the first and second arrays. Usually, the second electrode array will also include a second axial conductor extending part of the way to the first array, and the second axial
30

conductor will usually extend axially beyond the tips of the electrodes in the second electrode array. Thus, in a preferred embodiment, the proximal ends of the first axial conductors and the distal ends of the second axial conductors will lie closer to each other than will any of the tips of the individual electrodes in the two respective electrode arrays.

5 Such a structure will provide a preferred electrical conduction path through a gap left between the termini of the first and second axial conductors. The current path and resulting current flux between the first and the second arrays is thus concentrated initially within the center of the tissue volume being treated (i.e., along the axis between the two arrays) which would not be the case in the absence of the axial conductors.

10 It has been further found that the use of the preferred everting electrodes in the first and second arrays defines a generally ovoid lesion volume generally bounded by an outer cylindrical wall having hemispherical ends. Use of the axial conductors along the axis between those arrays helps to assure that tissue in the center of the treatment region is treated before the tissues lying at the outer cylindrical and hemispherical
15 peripheries of the treatment region is treated. After the central portions of the treatment region have been heated and necrosed to the extent that impedance to current flow increases, the individual electrodes of the electrode arrays will continue to heat and treat the outer portions. This two-step approach helps to assure that the entire volume, including both inner and outer portions of the treatment volume, is adequately necrosed.

20 Preferential heating of the center of the lesion can also reduce the effect of non-uniform blood flow at different points within the region to be treated. Destruction of the blood vessels within the center of the treatment region of tissue will tend to reduce perfusion differences in the larger, outer shell of the region. Moreover, even if the two electrode arrays experience different cooling because of such differences in blood flow,
25 the everted configuration of the two opposed electrode arrays will enhance creation of a substantially contiguous shell surrounding the preferentially heated core. This effect further reduces the non-uniformities created by differential cooling which has been a major problem in prior efforts to treat large tissue volumes with bipolar radiofrequency ablation.

30 In a further aspect of the present invention, methods for bipolar radiofrequency necrosis of the tissue comprise deploying a first array of electrodes and a second array of electrodes in tissue. The first electrode array is deployed on one side of a treatment region and includes both a transverse face and an axial conductor extending in an axial direction from the transverse face. Usually, the electrode array which is located

distally, i.e., furthest away from the entry point, will be deployed first in order to permit unimpeded imaging of the target tissue and the electrode during deployment. For that reason, the use of devices having separately deployable electrode arrays will often be preferred. Similarly, the second electrode array includes a transverse face and an axial
5 conductor extending in an axial direction opposed to the first axial conductor on the first electrode array. Bipolar radiofrequency current is then applied between the two electrode arrays to heat and necrose tissue therebetween. The first and second electrode arrays will preferably have concave surfaces and fully everted electrode tips which face each other, but the use of such concave electrode arrays is not necessary. For example, the electrode
10 arrays may be radially divergent, but not actually evert. Alternatively, the electrode arrays may be deployed by using a diverter to turn straight electrodes radially outward, as generally described in German patent application 2124684 to Stadelmayr.

The transverse faces of the first and second electrode arrays are preferably introduced from a single probe, but optionally could be introduced using two separate
15 probes, such as two separate LeVein™ Needle Electrodes as described previously. The LeVein™ Needle Electrodes would have to be modified to include the axial conductors, as described in more detail below.

The tissues to be treated and the treatment conditions will be generally the same as described above in connection with the earlier embodiments of the methods of
20 the present invention. Similarly, the electrode array dimensions will generally be the same as described above, except that the electrodes need not be concave or everting in all embodiments.

The present invention still further comprises kits including one or more probes capable of deploying at least first and second electrode arrays, generally as
25 described above. The kits will further include instructions for use for deploying the electrode arrays and applying bipolar radiofrequency current for treating a tumor or other diseased condition within a target body tissue. The method set forth in the instructions for use will generally be in accord with any of the methods described above for the present invention. Usually, the treatment probe will be packaged in a conventional
30 medical device package, such as a tray, box, tube, pouch, or the like. The instructions for use may be provided on a separate sheet of paper or may be printed in whole or in part on a portion of the packaging.

BRIEF DESCRIPTION OF THE DRAWINGS

Fig. 1 is a schematic illustration of the deployment of a first electrode array and a second electrode array in accordance with the methods of the present invention.

5 Figs. 1A-1C are schematic illustrations of the progression of tissue ablation achieved with the preferred treatment apparatus and methods of the present invention.

Fig. 2 illustrates a first exemplary electrode array deployment probe constructed in accordance with the principles of the present invention.

10 Fig. 3 is an enlarged portion of the electrode deployment array of Fig. 2 shown with portions broken away.

Fig. 4 illustrates the electrode deployment probe of Fig. 2, shown with the electrodes retracted.

Fig. 5 is an enlarged view of the distal end of the probe of Fig. 4.

15 Fig. 6 illustrates a second exemplary electrode deployment probe constructed in accordance with the principles of the present invention.

Fig. 7 is a detailed view of the distal end of the probe of Fig. 6.

Fig. 8 illustrates the use of a pair of separate electrode deployment probes for deploying electrodes in accordance with the methods of the present invention.

20 Fig. 9 illustrates a kit including an electrode deployment probe, instructions for use, and packaging in accordance with the principles of the present invention.

Fig. 10 is a perspective view of a third exemplary electrode deployment probe constructed in accordance with the principles of the present invention.

25 Figs. 11A and 11B are detailed views of the distal end of the probe of Fig. 10 illustrating a distal array deployed (Fig. 11A) and distal and proximal probes deployed (Fig. 11B).

Figs. 12A-12C illustrate the manner in which the electrode arrays are deployed from the probe of Fig. 10.

30 Fig. 13 is a detailed view of the handle of the probe of Fig. 10, with portions broken away.

DESCRIPTION OF THE SPECIFIC EMBODIMENTS

The present invention is intended to position electrode arrays, particularly bipolar arrays, relative to treatment regions within solid tissue of a patient. The treatment regions may be located anywhere in the body where hyperthermic exposure may be beneficial. Most commonly, the treatment region will comprise a solid tumor within an organ of the body, such as the liver, lung, kidney, pancreas, breast, prostate (not accessed via the urethra), uterus, and the like. The volume to be treated will depend on the size of the tumor or other lesion, but the present invention is particularly suitable for treating large treatment regions having the volumes and geometries set forth above. The peripheral dimensions of the treatment region may be regular, e.g., spherical or ellipsoidal, but will more usually be somewhat irregular. The lesion created to enclose the target tissue region utilizing this invention will usually be cylindrical or a truncated conical volume, as described in more detail below. The treatment region may be identified using conventional imaging techniques capable of elucidating a target tissue, e.g., tumor tissue, such as ultrasonic scanning, magnetic resonance imaging (MRI), computer-assisted tomography (CAT), fluoroscopy, nuclear scanning (using radiolabeled tumor-specific probes), and the like. Preferred is the use of high resolution ultrasound which can be employed to monitor the size and location of the tumor or other target tissue being treated, either intraoperatively or externally.

Apparatus according to the present invention will usually comprise at least one probe having a distal end adapted to be positioned beneath a tissue surface at or near the treatment region or regions. A first array of electrodes comprising a plurality of tissue-penetrating electrodes, typically in the form of sharpened, small cross-section metal elements are reciprocatably attached to the probe so that they penetrate into tissue as they are advanced from a first specific site (referred to hereinafter as the first target site) at or adjacent to a peripheral boundary of the treatment region, as described in more detail hereinafter. The primary requirement of such electrode elements is that they can be deployed in an array, preferably a three-dimensional array, emanating from the first treatment site within the treatment region of the tissue. Usually, the first electrode array will be deployed from a first target site on a "distal" side of the treatment region, i.e., the side which is most remote from the organ or tissue entry point. In the exemplary embodiments, the electrode elements are first introduced to the treatment region in a radially collapsed or other constrained configuration, and thereafter advanced into the tissue from a delivery cannula or other element in a divergent pattern to achieve the

desired three-dimensional array. The electrode elements will diverge radially outwardly from the delivery cannula (located at the first target site) in a uniform pattern, i.e., with the spacing between adjacent electrodes diverging in a substantially uniform and/or symmetric pattern. Preferably, adjacent electrodes will be spaced-apart from each other
5 in similar or identical, repeated patterns and will usually be symmetrically positioned about an axis of the delivery element. The electrode elements may extend or project along generally straight lines from the probe, but will more usually be shaped to curve radially outwardly and to evert proximally so that they face partially or fully in the proximal direction when fully deployed. It will be appreciated that a wide variety of
10 particular patterns can be provided to uniformly cover the region to be treated.

Apparatus according to the present invention will also comprise at least a second array of electrodes comprising a plurality of tissue-penetrating electrodes typically in the form of sharpened, small cross-section metal wires or elements. The second electrode array will usually be attached to the same probe as is the first electrode array.
15 In some instances, however, the methods of the present invention may utilize first and second electrode arrays which are deployed from separate probes and operated in a bipolar manner, as described in more detail below. The electrode wires or elements of the second array will be deployed from a second target site within the treatment region, usually on a "proximal" side thereof, i.e., the side which is closest to the organ or tissue
20 entry point. The electrodes of the second array will be introduced similarly to those of the first array, i.e., in a collapsed configuration, and subsequently deployed radially outwardly. In the exemplary embodiments, both the first and the second electrode arrays include everting electrode elements which form arrays having generally concave and convex surfaces. By facing the concave surfaces and electrode tips of the two electrode
25 arrays toward each other so that they are generally aligned along a common axis, usually defined by a shaft of the probe, radiofrequency and other high frequency currents may be applied to tissue in a manner which creates a uniform lesion, i.e., a lesion which is continuous and without significant portions of viable tissue, even when the region has portions which have different perfusion and different cooling characteristics.

30 Referring now to Fig. 1, a system 10 comprising a first electrode array 12 and a second electrode array 14 is schematically illustrated. The electrode arrays 12 and 14 are shown as fully everting arrays where individual electrode wires extend first in an axial direction, diverge radially outwardly, and turn back upon themselves until they face in an opposite direction from which they began. The first electrode array 12 further

includes an axial conductor 16 which extends along an axis line 18 toward a second axial conductor 20 which is part of the second electrode array 14. The first electrode array 12 has a concave surface 22 and a convex surface 24, and the second electrode array 14 also has a concave surface 26 and a convex surface 28. In a preferred aspect of the present invention, the concave surfaces at 22 and 26 of the electrode arrays 12 and 14 face each other along the axis line 18. The first axial conductor 16 and the second axial conductor 20 also face each other and extend toward each other, (usually beyond the inward terminations of the metal elements of the corresponding arrays 22 and 26) leaving a gap between the distal termini of each conductor 16 and 20 which is less than the distance between the inward terminations of the arrays 22 and 26. The current flow will initially be concentrated in this gap which is located in the central core of the tissue treatment region, as illustrated in Fig. 1A above. Preferably, the distance ℓ_2 between the inner termini 17 and 21 of the axial conductors 16 and 20 will be in the range from 0.25 to 0.75 of the distance ℓ_1 between the inner termini of the innermost portions of the electrode arrays 24 and 26. The treatment region will thus be heated and necrosed from the center outward, thus enhancing the ability to completely and uniformly necrose the entire tissue volume of the treatment region defined by the outward perimeters of the arrays 22 and 26, as illustrated in Fig. 1C above.

In the methods of the present invention, the first electrode array 12 and the second electrode array 14 will be disposed within tissue on opposite sides of a treatment region. The arrays will be disposed generally as shown in Fig. 1, preferably with the axial conductors 16 and 20 aligned along a common axis line, most preferably being positioned on a single probe shaft, as will be described in more detail hereinafter. The first electrode array 12 is connected to a first pole 30 of a radiofrequency power supply 32. A second electrode array 14 is connected to the other pole 34 of the power supply 32. In this way, the first electrode array and second electrode array will be powered in bipolar manner in order to effect radiofrequency current flow through the tissue volume between the arrays. Tissue destruction by the current will define the treatment region.

The geometry and volume of the treatment region within the patient tissue is determined by controlling various dimensions of the apparatus. For example, the arrays 12 and 14 will usually have outer circular diameters D in the range from 1 cm to 6 cm, usually from 2 cm to 4 cm. The diameters of each array will usually be the same, although they could differ in certain circumstances. When the diameters are the same, the

geometry of the lesion created will be generally cylindrical. When the diameters are different, the geometry could generally be a truncated cone. The distance between the electrode arrays ℓ_1 will usually be in the range from 2 cm to 10 cm, more usually in the range from 3 cm to 7 cm, and preferably in the range from 4 cm to 6 cm. The axial conductor 16 will typically have a length in the range from 0.5 cm to 2 cm, and the gap between the distal termini of the axial conductors 16 and 20 will typically have a length ℓ_2 in the range from 0.5 cm to 5 cm, usually from 1 cm to 3 cm. Usually, the inner termination 17 of the first axial conductor 16 will extend beyond the inner terminations of the individual electrodes in a first electrode array 22 by a distance ℓ_3 in the range from 0.5 cm to 2 cm, preferably from 0.7 cm to 1.3 cm. Similarly, the axial conductor 20 associated with the second electrode array 26 will terminate inwardly at 21 relative to the inward terminations of the individual electrodes, typically by a length in the ranges just set forth, more typically, having a length equal to ℓ_3 as also in the first axial conductor 16. The use of the axial conductors 16 and 20 is generally preferred since they provide a preferred current return path in bipolar operation which increases the current flux within the center of the region being treated. Such increased current flux, in turn, assures that the center of the treated region, e.g., along the axis line 18 between the tips 17 and 21 of the axial conductors 16 and 20, will be preferentially heated prior to the heating and necrosis of the outer portions of the treatment region. If the outer portions of the treatment region were treated first, it might be more difficult to assure that all portions, and in particular the inner portions, of the treatment region are adequately treated.

Referring to Figs. 1A-1C, the propagation of the tissue necrosis region achieved by the apparatus and methods of the present invention is schematically illustrated. Initially, the current flux is concentrated between the tips 17 and 21 of the axial conductors 16 and 20, resulting in a relatively small generally cylindrical or ovoid necrosis region, as shown in Fig. 1A. As the tissue become necrosed, its impedance increases, causing the current flux to move outwardly beyond the central core, creating a spheroidal region of necrosis, as shown in Fig. 1B. After the central region between arrays 22 and 26 including most or all of the volume surrounding the axial conductors becomes more fully necrosed, and the impedance increases over an even larger volume, current flow between the inner most tips of the individual conductors of the arrays 24 and 26 will increase, eventually resulting in the entire region between the arrays becoming

necrosed, as shown in Fig. 1C. Usually, the region of necrosis will extend slightly beyond the arrays themselves due to heat conduction from the tissue which is being directly heated by the electrical current flow. In addition to the impedance increase, the reduction of blood flow through the central portions of the treatment region as that tissue becomes necrosed will also contribute to the uniformity of heating and subsequent necrosis of the larger volume. That is, as the blood flow through the treatment region is decreased, the ability to uniformly heat the tissue via the passage of current is enhanced.

The RF power supply 32 may be a conventional general purpose electrosurgical power supply operating at a frequency in the range from 300 kHz to 1.2 MHz, with a conventional sinusoidal or non-sinusoidal wave form. Such power supplies are available from many commercial suppliers, such as Valleylab, Aspen, and Bovie. Most general purpose electrosurgical power supplies, however, are constant current, variable voltage devices and operate at higher voltages and powers than would normally be necessary or suitable for the methods of the present invention. Thus, such power supplies will usually be operated initially at the lower ends of their voltage and power capabilities, with voltage then being increased as necessary to maintain current flow. More suitable power supplies will be capable of supplying an ablation current at a relatively low fixed voltage, typically below 200V (peak-to-peak). Such low voltage operation permits use of a power supply that will significantly and passively reduce output in response to impedance changes in the target tissue. The output will usually be from 50W to 200W, usually having a sinusoidal wave form, but other wave forms would also be acceptable. Power supplies capable of operating within these ranges are available from commercial vendors, such as Radionics and RadioTherapeutics Corporation. A preferred power supply is model RF-2000, available from RadioTherapeutics Corporation, Mountain View, California, assignee of the present application.

The probe which contains the deployable electrode element arrays will usually comprise an elongate shaft, typically a rigid or semi-rigid, metal or plastic cannula. In some cases, the cannula will have a sharpened tip, e.g., be in the form of a needle, to facilitate introduction to the tissue treatment region. In such cases, it is desirable that the cannula or needle be sufficiently rigid, i.e., have sufficient column strength, so that it can be accurately advanced through tissue. In other cases, the cannula may be introduced using an internal stylet which is subsequently exchanged for one or more of the electrode arrays. In the latter case, the cannula can be relatively flexible since the initial column strength will be provided by the stylet. The cannula serves to constrain

the individual electrode elements of the electrode arrays in a radially collapsed configuration to facilitate their introduction to the tissue treatment region. The first electrode array can then be deployed to its desired configuration, usually a three-dimensional configuration, by extending distal ends of the electrode elements from the distal end of the cannula into the tissue. In the preferred case of the tubular cannula, this can be accomplished simply by advancing the distal ends of the electrode elements of the first electrode array distally from the tube so that they emerge and deflect (usually as a result of their own spring or shape memory) in a radially outward pattern. The electrode arrays of the second electrode array may then be proximally advanced from the tube so that they emerge and deflect (again, usually as a result of their own spring or shape memory) in a radially outward pattern which is a mirror image of the pattern formed by the first electrode array. Particular devices employing a single probe or elongate member for deploying such spaced-apart arrays will be described in more detail below.

Referring now to Figs. 2-5, a first exemplary electrode probe 50 will be described. The probe 50 has a coaxial design with a distal electrode array 52 and a proximal electrode array 54. The distal electrode array 52 is deployed by a distal conductor 56 which is attached to a slider 58 having a threaded end 60. The proximal electrode array 54 is attached to a proximal conductor 62 which, in turn, is attached to a proximal yoke 64. The proximal yoke 64 also has a threaded end 66 in a handle 68 of the probe 50. The handle 68, in turn, includes a stationary portion 70 and a rotatable portion 72. The rotatable portion 72 has a first threaded channel 74 which receives the threaded end 60 of the distal array slider 58. A second threaded channel 76 receives the threaded end 66 of the proximal yoke 64. In this way, rotation of the rotatable part 72 of handle 68 will simultaneously advance the distal slider 58 to deploy the distal electrode array 52 and retract the proximal yoke 64 which will deploy the proximal array 54, as best illustrated in Fig. 3. The proximal conductor 62 extends distally through an insulated outer sheath 80 and past a gap 82 (Fig. 4) between the sheath 80 and a proximal conductor tube 84. When the proximal array 50 is distally advanced, as shown in Figs. 4 and 5, the proximal array will be contained within a central lumen of the proximal conductor tube 84. As the array 54 is proximally advanced, by rotation of handle portion 72, the individual electrode tines advanced radially outwardly through the gap 82 and eventually extend to their fully everted configuration, as shown in Figs. 2 and 3.

While the proximal array 54 is being proximally deployed, the distal array 52 is simultaneously being deployed by advancing distally outwardly from a distal

conductor tube 86 at the distal end of the probe 50. When fully deployed, a distal electrode array 52, as shown in Figs. 2 and 3, is in electrical contact with the distal conductor 86 so that the array and conductor form an integrated electrode array of the type illustrated in Fig. 1. Similarly, the proximal electrode array 54 is in electrical contact with the proximal conductor tube 84. The two arrays and respective conductors form an integrated electrode structure similar to that shown in Fig. 1. A non-conductive gap 88 remains between the conductor tubes 86 and 84.

The probe 50 may be employed by introducing the probe into target tissue with both electrode arrays 52 and 54 completely withdrawn within their respective conductors 84 and 86. The probe 50 may be introduced directly using the sharpened distal tip 90 formed at the distal end of the distal conductor 84. Once at the desired target site, which may be determined using various imaging techniques as described above, the rotating portion 72 of handle 68 is rotated in order to advance both electrode arrays 52 and 54 into tissue. Thus, the two electrode arrays together envelope a tissue volume which becomes the treatment region when electrical power is applied. The proximal conductor 62 and distal conductor 56 are then connected to an electrosurgical power supply through connectors (not shown) on the handle 68.

Referring now to Figs. 6 and 7, a second exemplary probe 100 constructed in accordance with the principles of the present invention will be described. The probe 100 includes a distal array 102 and a proximal array 104, each of which comprise a plurality of individual evertng electrodes which may be similar in construction to those described in connection with probe 50. The distal array 102 is connected through a conductor 106 to a first rack 108. The proximal array 104 is connected to a conductor 110 which is connected to a second rack 112. The racks 108 and 112 are coupled by a pinion gear 114 so that pulling on a knob 116 in a proximal direction (arrow 118) causes the first rack 108 to move proximally and the second rack 112 to move distally. This way, the distal array 102 which is connected to rack 108 will be retracted proximally within the probe while the proximal array 104 will be retracted distally within the probe. Unlike probe 50, however, the distal array 102 and proximal array 104 are disposed in different, parallel tubular structures. The distal array 102 is disposed in a distal conductor tube 120, as best shown in Fig. 7, and the proximal array 104 is disposed in a proximal conductor tube 122. The distal conductor tube 120 and proximal conductor tube 122 are both electrically conductive so they act as axial conductors in conjunction with their respective arrays. Moreover, an insulated gap 124

exists between the electrically conductive tubes 120 and 122 to provide a gap between them, as generally described previously. Additionally, the distal tip 126 of at least the distal conductor tube 120 will be sharpened to facilitate tissue insertion. Optionally, the insulated gap region 124 at the distal end of the proximal conductor 122 may also be tapered or beveled in order to facilitate insertion.

As best seen in Fig. 7, the proximal conductor 110 and distal conductor 106 will both extend through parallel tubes which are covered by an insulating material 130. Thus, the probe 100 may be used in generally the same manner as described for prior probe 50.

Referring now to Fig. 8, the methods of the present invention may be performed using separate electrode deployment probes 160 and 170, such as the LeVein™ Needle Electrodes described previously. To use such separate probes, they should be inserted to a tissue region in generally opposite directions along coincident axes to lie side-by-side, as illustrated in Fig. 8. The electrode arrays 162 and 172 may then be deployed in a manner such that the concave faces 164 and 174 of the arrays are opposed along a generally axial line therebetween. Preferably, at least a portion of each probe 160 and 170 will be modified to provide an axial conductor. For example, a distal portion 168 of the shaft of electrode deployment probe 160 may have an insulating sheath removed so that it becomes electrically conductive. In this way, the deployed array 162 will be electrically coupled to a conductor region 168 which forms an axial conductor for use in the methods of the present invention. Similarly, a distal portion 178 of probe 170 may also have its insulation removed so that it becomes electrically active and acts as an axial conductor in combination with the electrode array 172. Once the electrode arrays 162 and 172 are deployed as shown in Fig. 8, they may be electrically powered and used to perform methods according to the present invention as described above.

Referring now to Fig. 9, a kit according to the present invention will include at least a single electrode deployment probe, such as probe 50, and instructions for use IFU. The instructions for use will set forth a method for deploying a pair of electrodes from probe 50 in tissue in accordance with any of the methods described hereinabove. The instructions for use will generally be written on a package insert or other separate piece of paper or enclosure, but could also be printed in whole or in part on other packing materials. Usually, all components of the kit will be packaged together in a conventional package 200, such as a pouch, tray, box, tube, or the like. Preferably, the

probe 50 will be sterilized within the package so that they are immediately ready for use in a sterile environment.

Referring to Figs. 10, 11A, and 11B, a fourth exemplary electrode probe 300 will be described. The electrode probe 300 has a coaxial design with a distal electrode array 302 (Fig. 11A) and a proximal electrode array 304 which may be separately deployed. As shown in Fig. 11A, the distal electrode array 302 has been deployed while the proximal array 304 remains retracted within the electrode probe 300. As shown in Fig. 11B, both the distal electrode array 302 and the proximal electrode array 304 have been deployed. While it is not illustrated, it also possible to deploy the proximal electrode array 304 without having deployed the distal electrode array 302.

The primary components of the electrode probe 300 are generally the same as those for the prior embodiments of the electrode probes of the present invention. The electrode probe 300 includes a shaft 306 having a distal end 308 and a proximal end 310. A handle structure 312 is attached to the proximal end 310 of the shaft 306 and includes a cylindrical body 314 and a deployment knob 316. A portion or region 318 of the cylindrical body 314 is transparent to permit viewing of a translatable marker ring 320, as will be described in more detail hereinafter. The shaft 306 will preferably have a sharpened or otherwise tissue-penetrating tip 322, as generally described above in connection with prior embodiments.

The distal array 302 will be electrically coupled to a portion of the shaft 324, which provides the axial conductor described in connection with prior embodiments. Similarly, the proximal electrode array 304 will be electrically coupled to a second portion 326 of the shaft, which also provides an axial conductor as described above. Thus, when fully deployed, the electrode arrays 302 and 304 together with respective axial conductors 324 and 326 will provide the electrode array configuration as shown in Fig. 1. The axial conductors 324 and 326 will be separated by an electrically non-conductive portion 328 of the shaft. The electrode probe 300 will further include a first cylindrical conductor 330 for attaching an external power supply to the proximal array 304. A second conductor 332 (Fig. 13) is provided in the knob 316 of the handle structure 312 for connecting the distal array 302 to the external power supply.

Referring now to Figs. 12A-12C, sequential deployment of the electrode arrays 302 and 304 using the electrode probe 300 will be described. As shown in Fig. 12A, the electrode probe 300 is in its initial or shelf configuration with both electrode arrays 302 and 304 being retracted within the shaft 306. The deployment knob 316 will

be positioned in its proximal-most position relative to the cylindrical body 314 of handle 312. Initially after the sharpened tip 322 of shaft 306 is introduced through solid tissue to a desired target site, either the distal array 302 or the proximal array 304 may be selectively deployed. As shown in Fig. 12B, the distal array 302 is deployed by
5 depressing the knob 326, i.e., axially translating the knob relative to the cylindrical body 312 in a distal direction so that the electrode array 302 is advanced distally from the distal end of the shaft 306. As with the prior embodiments, the distal electrode array 302 will first emerge in a distal direction and then diverge, typically to form an everted configuration as illustrated. The proximal array 306 is separately deployed by rotating
10 the handle 316 as illustrated by the arrow 340 in Fig. 12C. Such rotation causes the proximal electrode array 304 to first advance proximally relative to the shaft 306 and then to diverge radially outwardly. Again, in the preferred embodiment, the proximal array will also evert so that its tips end up pointed toward the tips of the electrodes in the distal electrode array 302, as shown in Fig. 12C. In addition to deploying the proximal
15 array 304, twisting of the handle 306 causes the marker ring 320 to axially translate in a proximal direction from the initial position, as shown in Figs. 12A and 12B, to a final position as shown in Fig. 12C. Movement of the marker 320 allows the physician to visually confirm whether or not the proximal electrode array 304 has been deployed. Determination of whether the distal electrode array 302 has been deployed can readily be
20 made based on the axial position of the knob 316. When in the proximally extended configuration of Fig. 12A, the physician knows that the distal electrode array 302 has not been deployed. When it is fully advanced in a distal direction, as shown in Figs. 12B and 12C, the physician will know that the distal array 302 has been deployed.

A wide variety of internal mechanisms can be provide for allowing the
25 separate deployment of the distal electrode array 302 and the proximal electrode array 304. A particular exemplary structure is shown in Fig. 13, where portions of the handle structure 312 are broken away to reveal the inner components thereof. The deployment knob 316 is attached to a slideable sleeve 344 which enables the knob to rotate and axially reciprocate within the body 314 of the handle, as shown in
30 Figs. 12A-12C above. In addition, the knob 316 captures rotatable terminal 344 which, in turn, is connected to a coupling shaft 360. Axial movement of the knob 316 causes both the terminal 342 and shaft 360 to reciprocate and deploy the distal array 302. Temporary retaining ring 370 and spacer 372 will be removed prior to deployment.

The knob 316 is also coupled to a rotatable core 346 which rotates with the knob. Rotation of the core 346 engages threads 348 on a shuttle 350 which axially translates in response to rotation of the knob 316. Axial translation of the shuttle, in turn, translates a shaft 352 which is connected to and deploys the proximal electrode array 304.

5 In this way, the arrays 302 and 304 may be independently and separately deployed using the knob, as generally shown above in Figs. 12A and 12C. A marker surface 320 will be present on the shuttle 350 so that the marker will move and be visible through the transparent region 318 of the handle. Electrical terminals 380 and 382 are provided for connection to a bipolar power supply, generally as shown in Fig. 1.

10 While the above is a complete description of the preferred embodiments of the invention, various alternatives, modifications, and equivalents may be used. Therefore, the above description should not be taken as limiting the scope of the invention which is defined by the appended claims.

WHAT IS CLAIMED IS:

1 1. A probe for deploying electrode arrays, said probe comprising:
2 a shaft having a distal end and a proximal end;
3 a first array of electrodes mounted on the shaft to shift between a retracted
4 configuration and a deployed configuration having a concave face; and
5 a second array of electrodes mounted on the shaft at a location spaced-
6 apart proximally from first array of electrodes, wherein the second electrode array shifts
7 between a retracted and a deployed configuration having a concave face;
8 wherein concave faces are opposed to each other when the arrays are
9 deployed.

1 2. A probe as in claim 1, wherein the first and second electrode arrays
2 each comprise a plurality of individual electrodes which initially move axially and then
3 evert as they are deployed.

1 3. A probe as in claim 1, wherein the shaft has a self-penetrating tip.

1 4. A probe as in claim 1 or 3, wherein the shaft has at least once
2 cavity for receiving the first and second electrode arrays when retracted.

1 5. A probe as in claim 1 or 3, wherein the shaft has at least one cavity
2 for receiving the first electrode array when retracted and at least a second cavity for
3 receiving the second electrode array when retracted.

1 6. A probe as in claim 1 or 3, further comprising:
2 a first rod connected to the first electrode array and slidably disposed in
3 the shaft, wherein distal advancement of the first rod relative to the shaft causes the first
4 electrode array to deploy distally;
5 a second rod connected to the second electrode array and slidably disposed
6 in the shaft, wherein proximal retraction of the second rod relative to the shaft causes the
7 second electrode array to deploy proximally.

1 7. A probe as in claim 1 or 3, wherein the first electrode array spans a
2 planar area in the range between 3 cm² to 20 cm² when deployed, the second electrode
3 array spans a planar area in the range between 3 cm² and 20 cm² when deployed, and the

4 first and second areas are spaced-apart along a line between their respective centers by a
5 distance in the range between 2 cm to 10 cm.

1 8. A probe as in claim 1 or 3, wherein the volume between the first
2 electrode array when deployed and the second electrode when deployed is in the range
3 from 30 cm³ to 150 cm³.

1 9. A probe as in claim 8, wherein the volume is in the range from
2 50 cm³ to 70 cm³.

1 10. A probe as in claim 1 or 3, wherein the first electrode array and
2 second electrode array are electrically isolated from each other, further comprising a first
3 connector for connecting the first electrode array to one pole of a power supply and a
4 second connector for connecting the second array to a second pole of a power supply.

1 11. A probe as in claim 10, further comprising a first axial conductor
2 extending proximally along the shaft from the first electrode array to a location distal to
3 the second electrode array, said first axial conductor being electrically coupled to the first
4 electrode array.

1 12. A probe as in claim 11, wherein the first axial conductor extends
2 proximally beyond the proximal terminus of the first electrode array so that the first axial
3 conductor lies closer to the second electrode array than does any portion of the first
4 electrode array.

1 13. A probe as in claim 11, further comprising a second axial
2 conductor extending distally along the shaft from the second electrode array to a location
3 proximal to the first axial conductor so that a gap exists between the first and second axial
4 conductors, said second axial conductor being electrically coupled to the second electrode
5 array.

1 14. A probe as in claim 13, wherein the second axial conductor extends
2 distally beyond the distal terminus of the second electrode array so that the second axial
3 conductor lies closer to the first electrode array than does any portion of the second
4 electrode array.

1 15. A probe as in claim 13, wherein the distance between the inner
2 termini of the first and second axial conductors is from 0.25 to 0.75 of the distance
3 between the inner termini of the innermost portions of the first and second electrode
4 arrays.

1 16. A method for treating a treatment region in tissue, said method
2 comprising:
3 deploying a first array of electrodes in tissue on one side of the treatment
4 region, wherein said first electrode array has a concave face;
5 deploying a second array of electrodes in tissue along an axis with the first
6 array on another side of the treatment region, wherein said second electrode array has a
7 concave face wherein the concave face of the first electrode array faces the concave face
8 of the second electrode array; and
9 applying electrical current between the first and second electrode arrays.

1 17. A method as in claim 16, wherein deploying the first electrode
2 array comprises introducing a first probe through tissue to a location on one side of the
3 treatment region and advancing a first plurality of at least three electrodes from the probe
4 in an everting pattern.

1 18. A method as in claim 17, wherein deploying the second electrode
2 array comprises advancing a second plurality of at least three electrodes from the probe in
3 an everting pattern at a location on the other side of the treatment region.

1 19. A method as in claim 17, wherein deploying the second electrode
2 array comprises introducing a second probe through tissue to a location on the other side
3 of the treatment region and advancing a plurality of at least three electrodes in an everting
4 pattern.

1 20. A method as in claims 16-19, wherein the tissue is selected from
2 the group consisting of liver, lung, kidney, pancreas, stomach, uterus, and spleen.

1 21. A method as in claim 20, wherein the treatment region is a tumor.

1 22. A method as in claim 16-19, wherein electrical current is applied at
2 a frequency in the range from 300 kHz to 1.2 MHz.

1 23. A method as in claim 22, wherein electrical current is applied at a
2 power in the range from 50W to 300W.

1 24. A method as in claims 16-19, wherein applying electrical current
2 comprises coupling one pole of a radiofrequency power supply to the first electrode array
3 and another pole of the radiofrequency power supply to the second electrode array and
4 energizing the power supply.

1 25. A method as in claims 16-19, wherein the first and second
2 electrode arrays each span a planar area in the range between 3 cm^2 to 20 cm^2 , and
3 wherein the first and second arrays are spaced-apart along a line between their respective
4 centers by a distance in the range between 2 cm to 10 cm.

1 26. A method as in claims 16-19, wherein the tissue volume between
2 the first electrode array and the second electrode is in the range from 30 cm^3 to 150 cm^3 .

1 27. A method as in claim 26, wherein the volume is in the range from
2 50 cm^3 to 70 cm^3 .

1 28. A method as in claims 16-19, wherein said first electrode array
2 includes a first axial conductor extending at least part of the way to the second array
3 along the axis therebetween.

1 29. A method as in claim 28, wherein the first axial conductor extends
2 proximally beyond the proximal terminus of the first electrode array so that the first axial
3 conductor lies closer to the second electrode array than does any portion of the first
4 electrode array.

1 30. A method as in claim 28, wherein said second electrode array
2 includes a second axial conductor extending part of the way to the first array along the
3 axis therebetween and wherein there is a gap between termini of the first axial conductor
4 and the second axial conductor.

1 31. A method as in claim 30, wherein the second axial conductor
2 extends distally beyond the distal terminus of the second electrode array so that the

3 second axial conductor lies closer to the first electrode array than does any portion of the
4 second electrode array.

1 32. A method as in claim 31, wherein the distance between inner
2 termini of the first and second axial conductors is from 0.25 to 0.75 of the distance
3 between the inner termini of the innermost portions of the first and second electrode
4 arrays.

1 33. A method for bipolar radiofrequency necrosis of tissue, said
2 method comprising:

3 deploying a first array of electrodes in tissue on one side of a treatment
4 region, wherein said first array has a transverse face and an axial conductor extending in
5 an axial direction from the transverse face;

6 deploying a second array of electrodes in tissue on another side of the
7 treatment region, wherein said second array has a transverse face and an axial conductor
8 extending in an axial direction opposed to the axial conductor on the first electrode array;
9 and

10 applying bipolar radiofrequency current to the tissue between the first and
11 second electrode arrays.

1 34. A method as in claim 33, wherein deploying the transverse face of
2 the first electrode array comprises introducing a first probe through tissue to a location on
3 one side of the treatment region and advancing a first plurality of at least three electrodes
4 from the probe in a radially diverging pattern.

1 35. A method as in claim 34, wherein the diverging pattern is everting.

1 36. A method as in claim 34 or 35, wherein deploying the transverse
2 second electrode array comprises advancing a second plurality of at least three electrodes
3 from the probe in a radially diverging pattern at a location on the other side of the
4 treatment region.

1 37. A method as in claim 36, wherein the diverging pattern is everting.

1 38. A method as in claim 34 or 35, wherein deploying the transverse
2 face of the second electrode array comprises introducing a second probe through tissue to

3 a location on the other side of the treatment region and advancing a plurality of at least
4 three electrodes in a radially diverging pattern.

1 39. A method as in claim 38, wherein the diverging pattern is everting.

1 40. A method as in claims 33, 34, or 35, wherein the tissue is selected
2 from the group consisting of liver, lung, kidney, pancreas, stomach, uterus, and spleen.

1 41. A method as in claim 40, wherein the treatment region comprises a
2 tumor lesion.

1 42. A method as in claims 33, 34, or 35, wherein the bipolar
2 radiofrequency current is applied at a frequency in the range from 300 kHz to 1.2 MHz.

1 43. A method as in claim 42, wherein the bipolar radiofrequency
2 current is applied at a power in the range from 50W to 300W.

1 44. A method as in claims 33, 34, or 35, wherein applying the bipolar
2 radiofrequency current comprises coupling one pole of a radiofrequency power supply to
3 the first electrode array and another pole of the radiofrequency power supply to the
4 second electrode array and energizing the power supply.

1 45. A method as in claims 33, 34, or 35, wherein the transverse face of
2 the first electrode array spans a planar area in the range between 3 cm^2 to 20 cm^2 , the
3 transverse face of the second electrode array spans a planar area in the range between
4 3 cm^2 and 20 cm^2 , and the first and second arrays are spaced-apart along an axial line
5 between their respective centers by a distance in the range between 2 cm and 10 cm.

1 46. A method as in claim 45, wherein the termini of axial conductors
2 of the first and second electrode arrays are spaced-apart in the axial direction by a
3 distance in the range between 0.5 cm and 5 cm.

1 47. A method as in claim 33, wherein the tissue volume between the
2 transverse face of the electrode array and the transverse face of the second electrode is in
3 the range from 30 cm^3 to 150 cm^3 .

1 48. A method as in claim 33, wherein the distance between the termini
2 of the first and second axial conductors is from 0.25 to 0.75 of the distance between the
3 inner termini of the innermost portions of the first and second electrode arrays.

1 49. A kit for treating a treatment region in tissue, said kit comprising:
2 a first array of electrodes which are deployable in tissue;
3 a second array of electrodes which are deployable in tissue; and
4 instructions for use setting forth a method according to claim 16 or 33.

1 50. A kit as in claim 41, further comprising a package for holding the
2 first electrode array, the second electrode array, and the instruction for use.

1 51. A probe for deploying electrode arrays, said probe comprising:
2 a shaft having a distal end and a proximal end;
3 a first array of electrodes mounted on the shaft to shift between a retracted
4 configuration and a deployed configuration; and
5 a second array of electrodes mounted on the shaft at a location spaced-
6 apart proximally from the first array of electrodes, wherein the second electrode array
7 shifts between a retracted and a deployed configuration;
8 wherein the first array is electrically isolated from the second array to
9 permit the arrays to be connected to a power supply for bipolar operation.

1 52. A probe as in claim 51, wherein the first and second electrode
2 arrays each comprise a plurality of individual electrodes which initially move axially and
3 then evert as they are deployed.

1 53. A probe as in claim 51, wherein the shaft has a self-penetrating tip.

1 54. A probe as in claim 51 or 53, wherein the shaft has at least once
2 cavity for receiving the first and second electrode arrays when retracted.

1 55. A probe as in claim 51 or 53, wherein the shaft has at least one
2 cavity for receiving the first electrode array when retracted and at least a second cavity
3 for receiving the second electrode array when retracted.

1 56. A probe as in claim 51 or 53, further comprising:

2 a first rod connected to the first electrode array and slidably disposed in
3 the shaft, wherein distal advancement of the first rod relative to the shaft causes the first
4 electrode array to deploy distally;

5 a second rod connected to the second electrode array and slidably disposed
6 in the shaft, wherein proximal retraction of the second rod relative to the shaft causes the
7 second electrode array to deploy proximally.

1 57. A probe as in claim 56, wherein the first and second rods may be
2 deployed separately.

1 58. A probe as in claim 51 or 53, wherein the first electrode array
2 spans a planar area in the range between 3 cm^2 to 20 cm^2 when deployed, the second
3 electrode array spans a planar area in the range between 3 cm^2 and 20 cm^2 when
4 deployed, and the first and second areas are spaced-apart along a line between their
5 respective centers by a distance in the range between 2 cm to 10 cm.

1 59. A probe as in claim 51 or 53, wherein the volume between the first
2 electrode array when deployed and the second electrode when deployed is in the range
3 from 30 cm^3 to 150 cm^3 .

1 60. A probe as in claim 59, wherein the volume is in the range from
2 50 cm^3 to 70 cm^3 .

1 61. A probe as in claim 51 or 53, wherein the first electrode array and
2 second electrode array are electrically isolated from each other, further comprising a first
3 connector for connecting the first electrode array to one pole of a power supply and a
4 second connector for connecting the second array to a second pole of a power supply.

1 62. A probe as in claim 61, further comprising a first axial conductor
2 extending proximally along the shaft from the first electrode array to a location distal to
3 the second electrode array, said first axial conductor being electrically coupled to the first
4 electrode array.

1 63. A probe as in claim 62, wherein the first axial conductor extends
2 proximally beyond the proximal terminus of the first electrode array so that the first axial

3 conductor lies closer to the second electrode array than does any portion of the first
4 electrode array.

1 64. A probe as in claim 62, further comprising a second axial
2 conductor extending distally along the shaft from the second electrode array to a location
3 proximal to the first axial conductor so that a gap exists between the termini of the first
4 and second axial conductors, said second axial conductor being electrically coupled to the
5 second electrode array.

1 65. A probe as in claim 64, wherein the second axial conductor extends
2 distally beyond the distal terminus of the second electrode array so that the second axial
3 conductor lies closer to the first electrode array than does any portion of the second
4 electrode array.

1 66. A probe as in claim 64, wherein the distance between the inner
2 termini of the first and second axial conductors is from 0.25 to 0.75 of the distance
3 between the inner termini of the innermost portions of the first and second electrode
4 arrays.

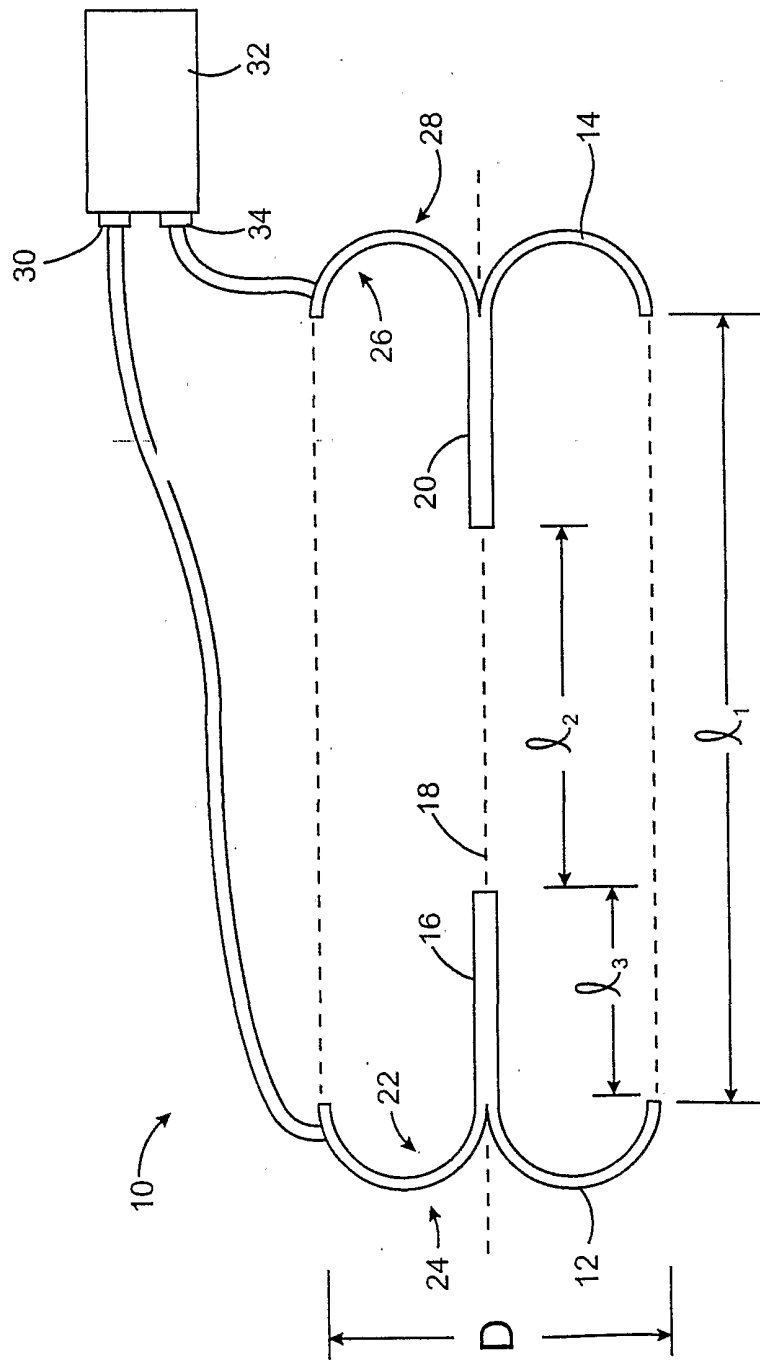

FIG. 1

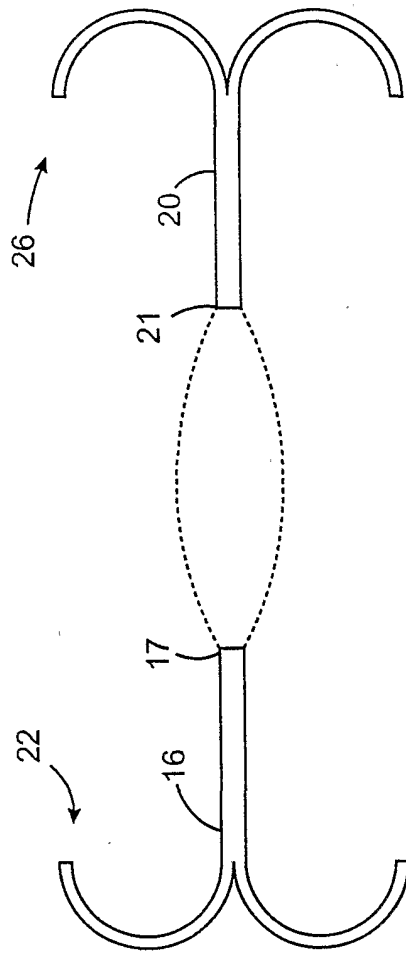

FIG. 1A

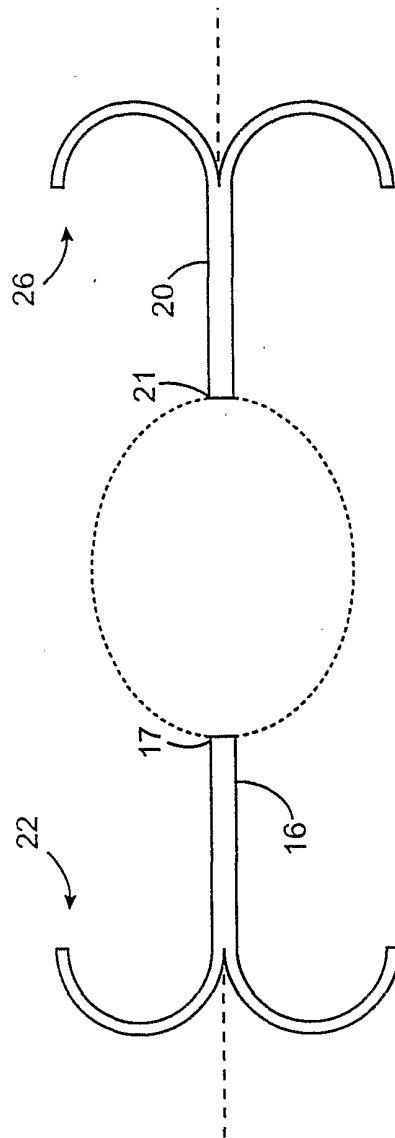

FIG. 1B

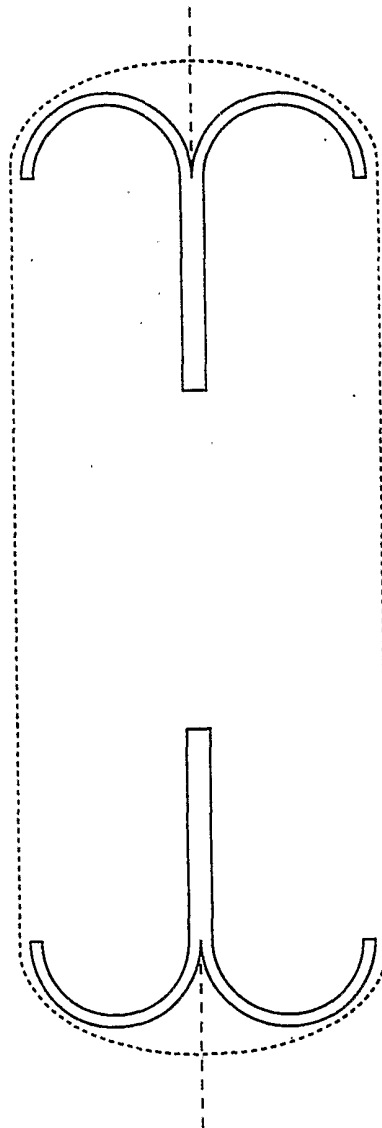
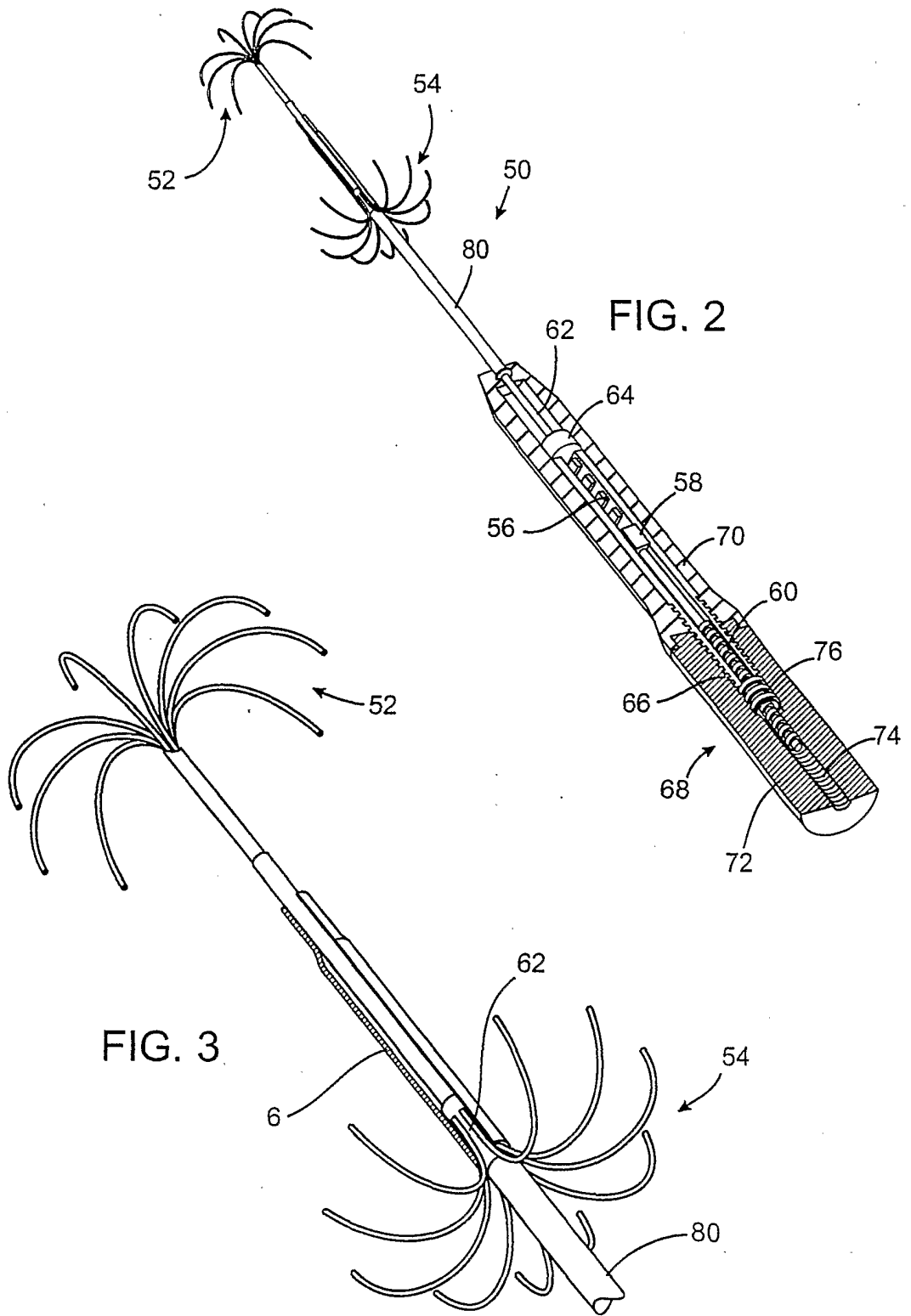

FIG. 1C



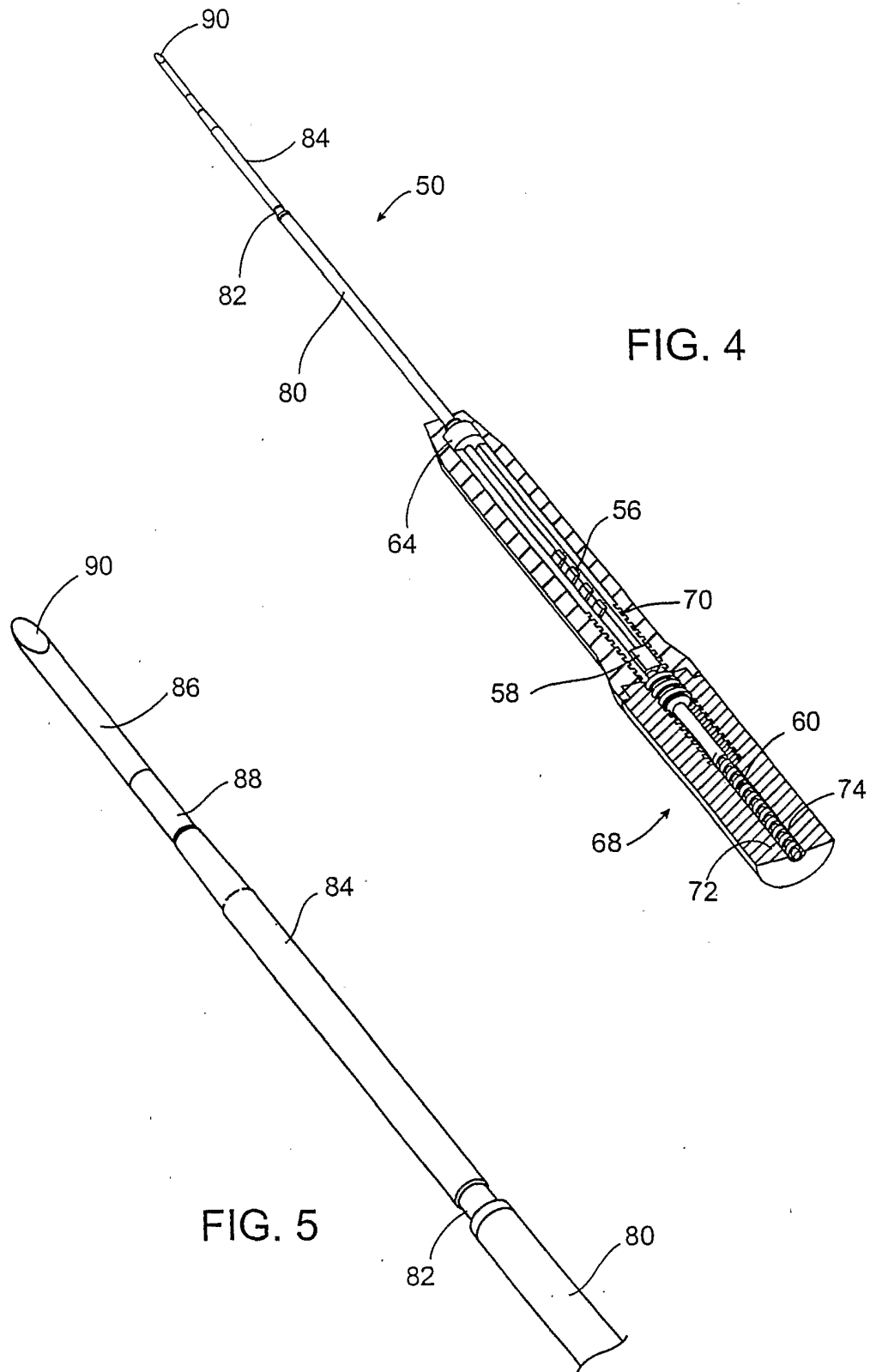

FIG. 4

FIG. 5

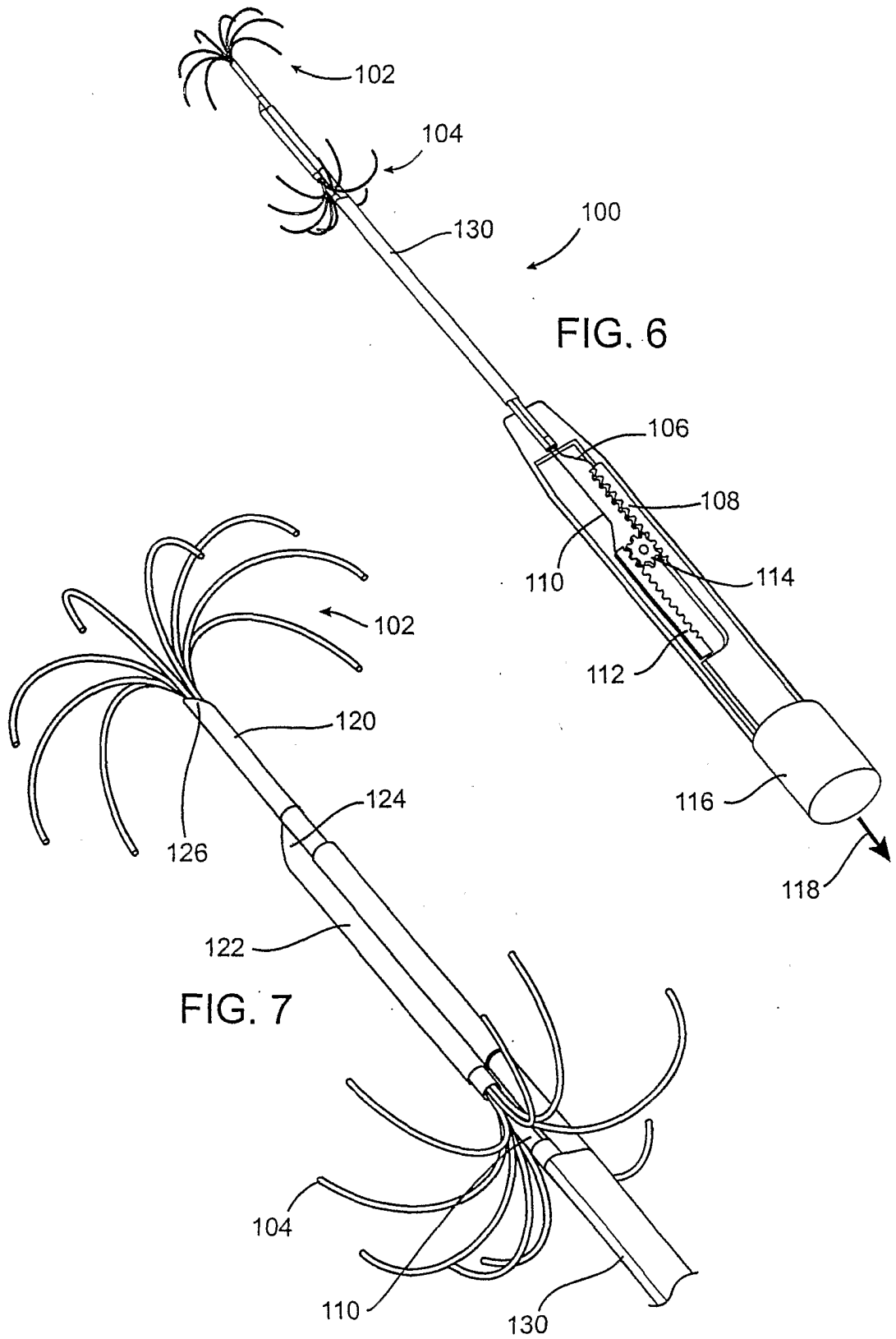
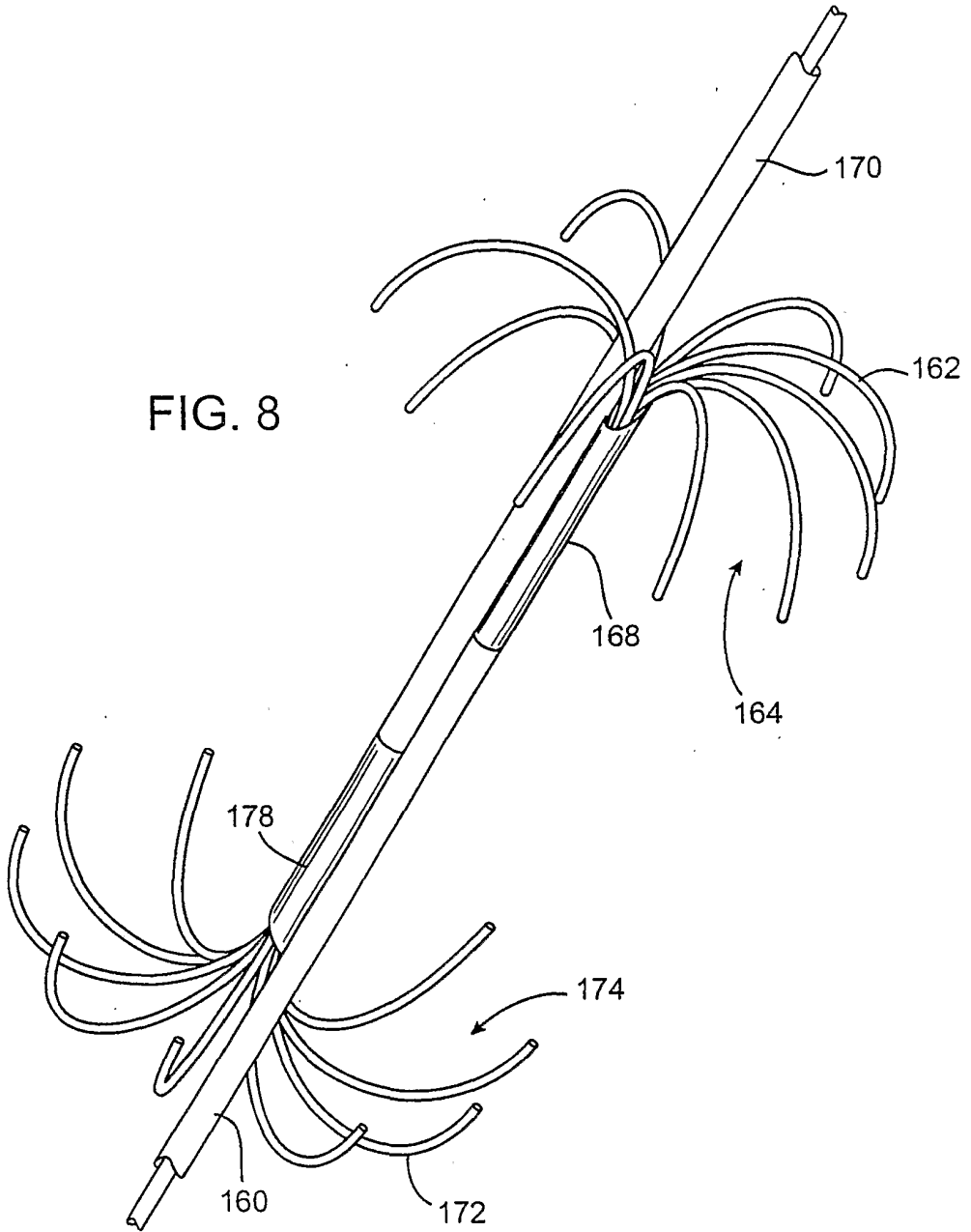

FIG. 8



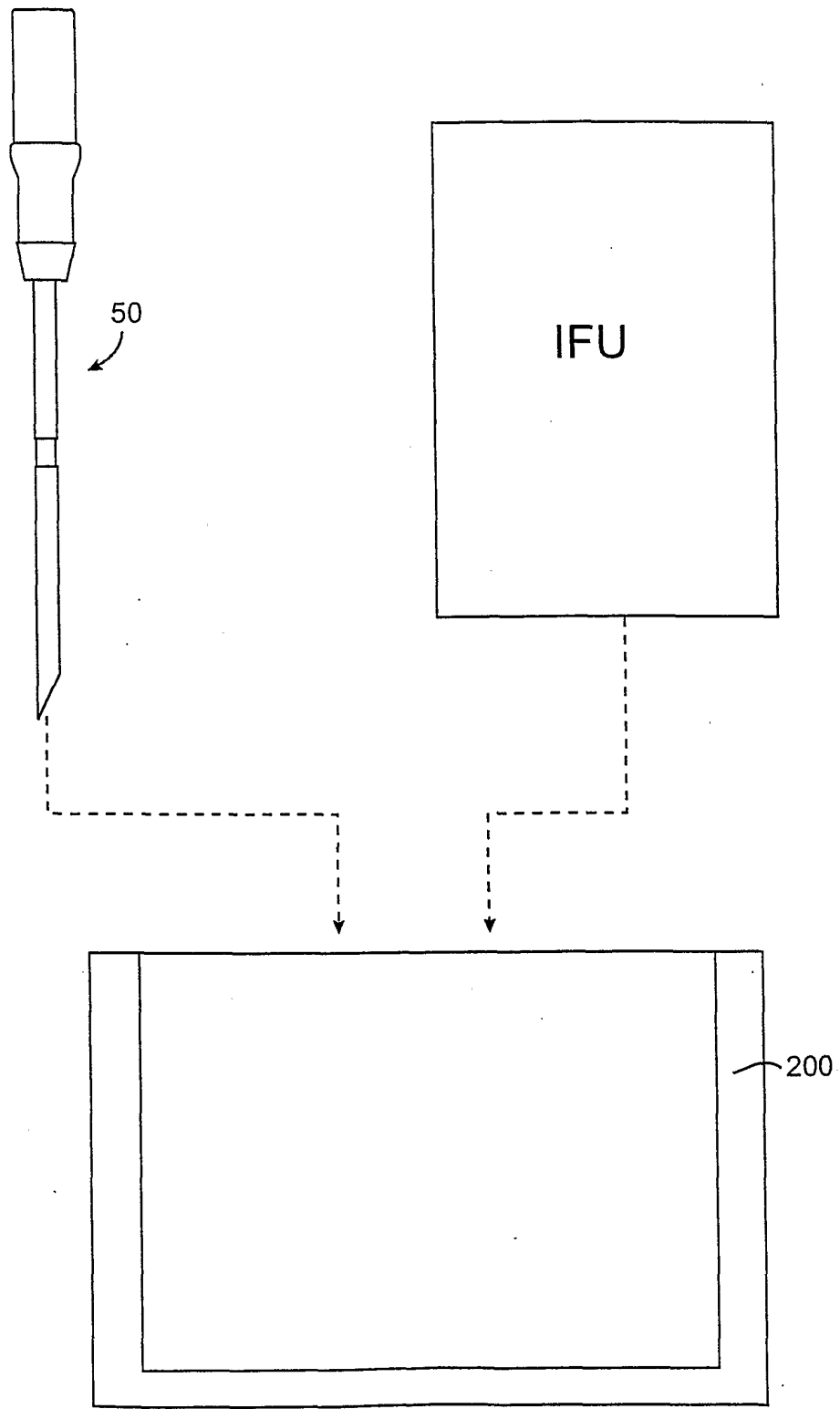

FIG. 9

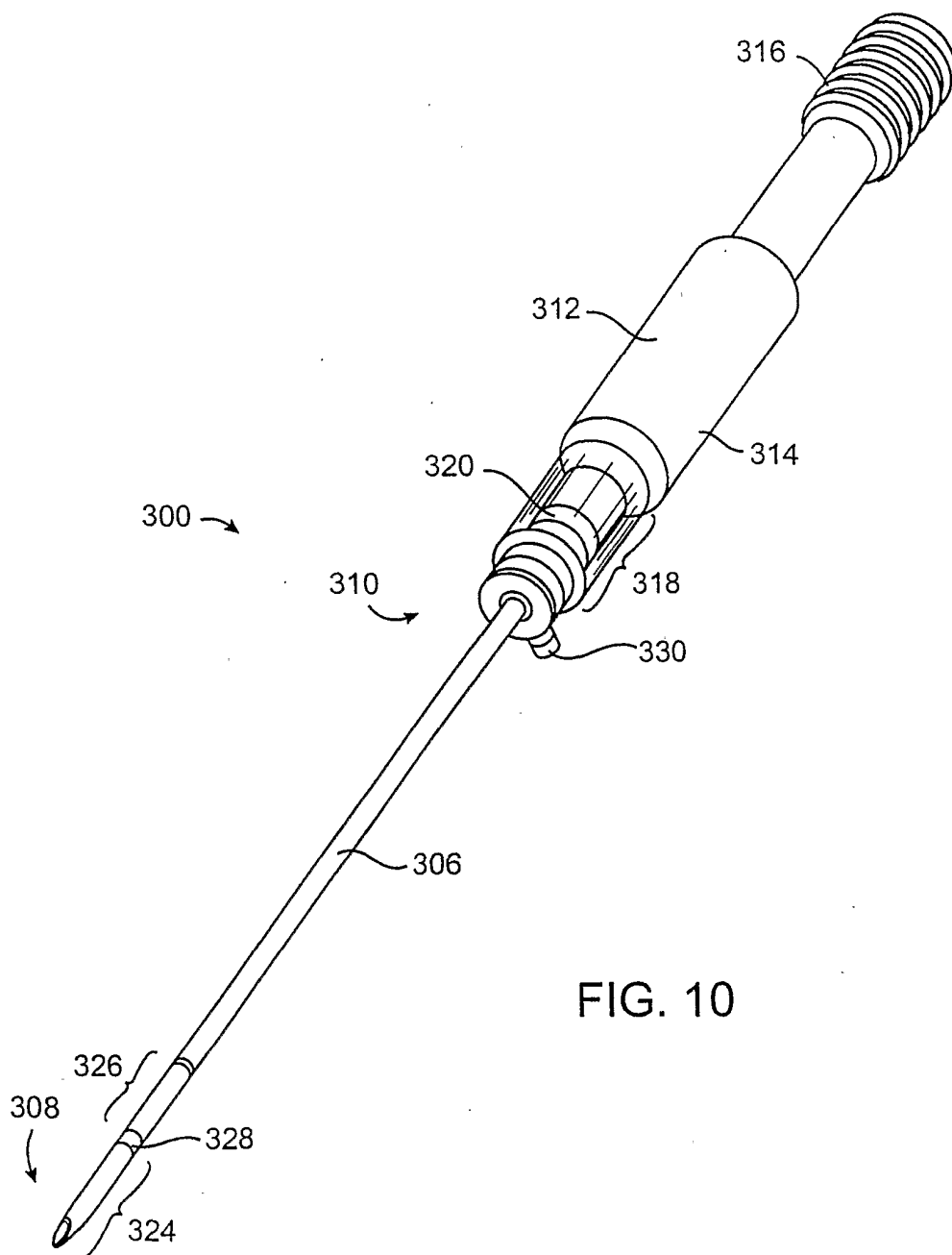

FIG. 10

FIG. 11A

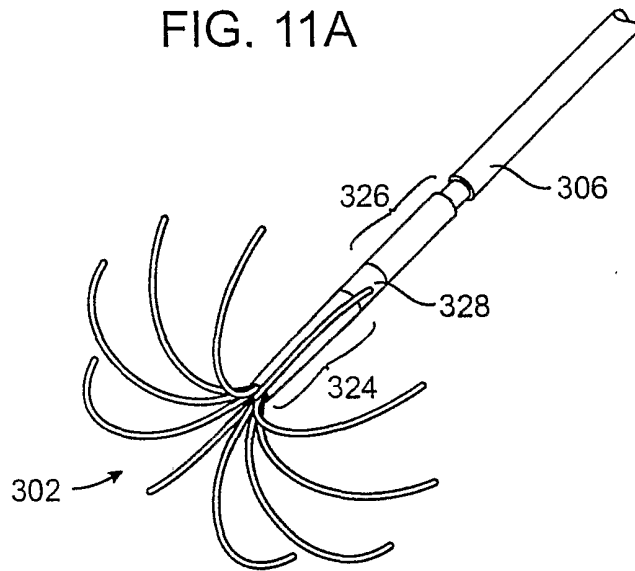
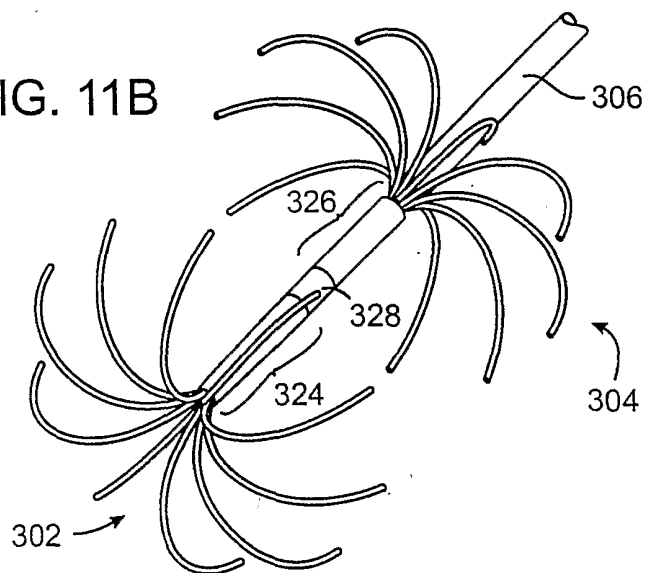
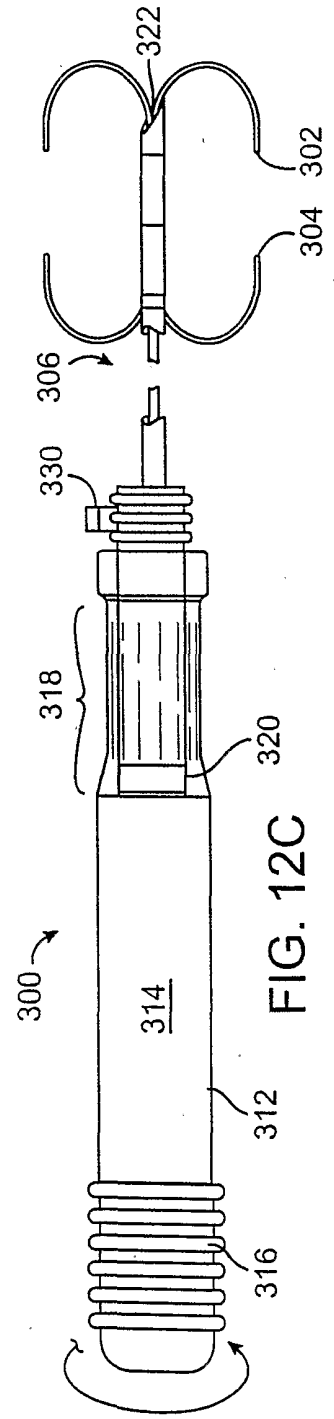
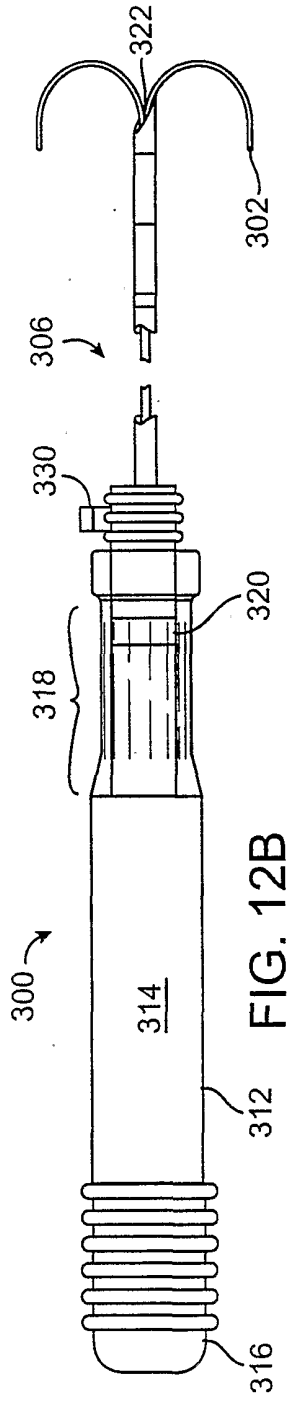
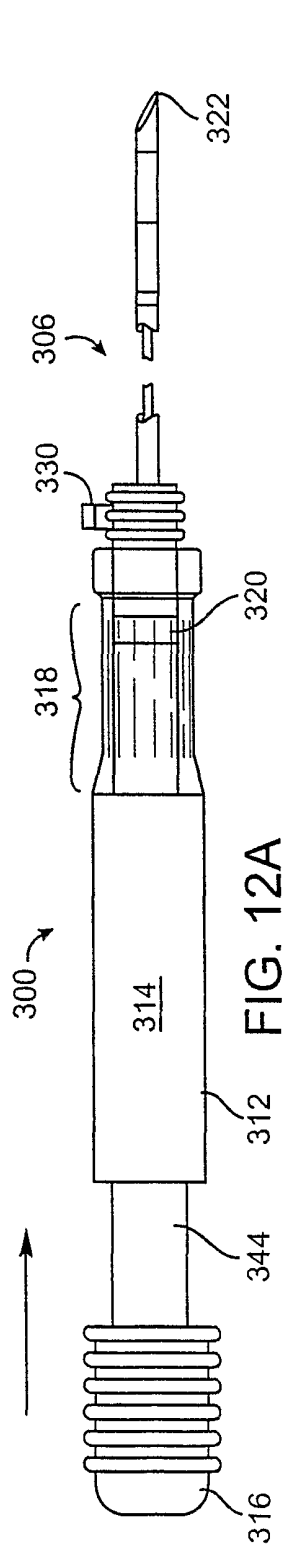

FIG. 11B





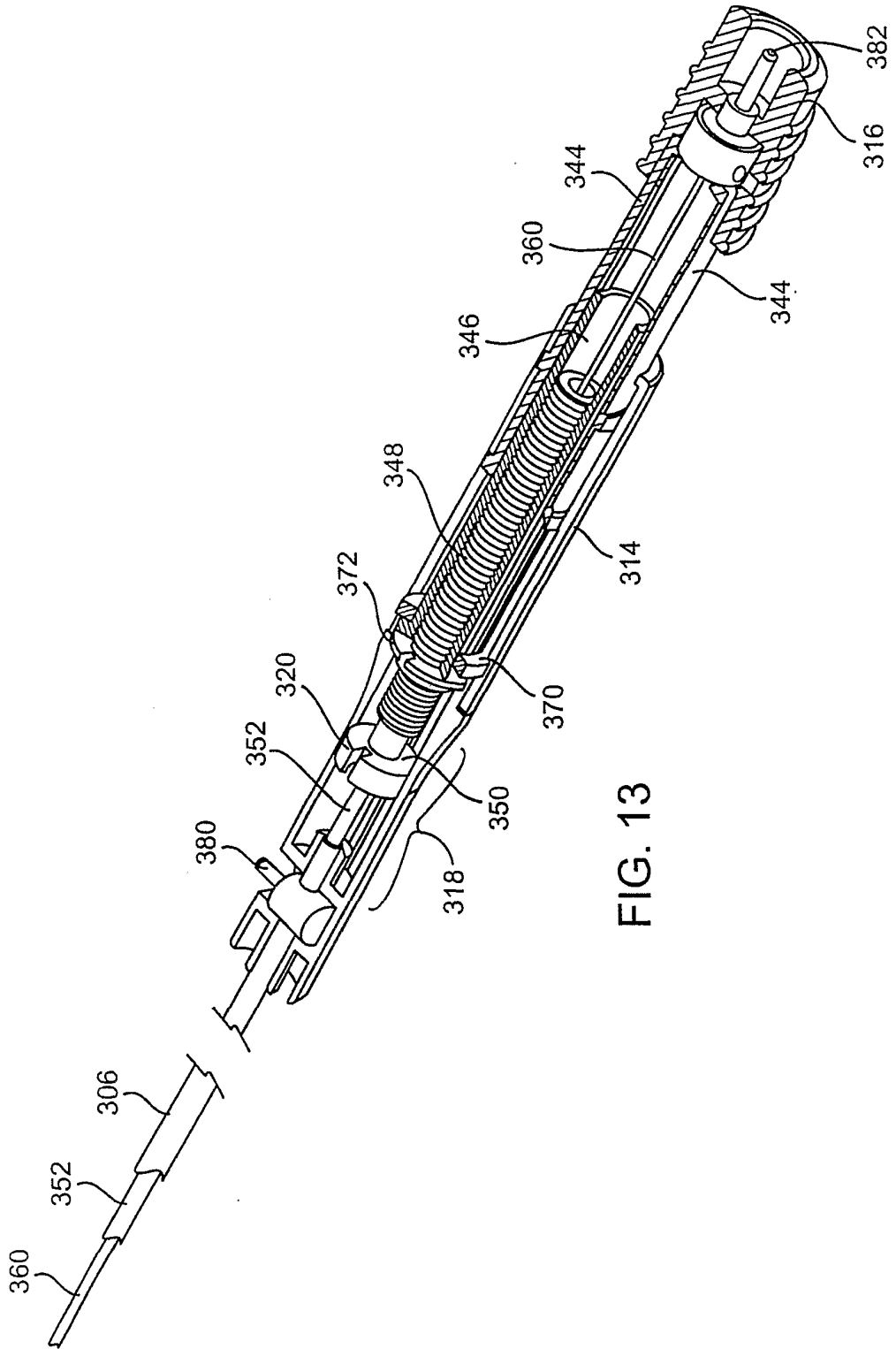

FIG. 13

INTERNATIONAL SEARCH REPORT

International application No.
PCT/US01/28707

A. CLASSIFICATION OF SUBJECT MATTER

IPC(7) :A61B 18/18
US CL :606/041

According to International Patent Classification (IPC) or to both national classification and IPC

B. FIELDS SEARCHED

Minimum documentation searched (classification system followed by classification symbols)

U.S. : 606/041, 32, 34, 40, 42, 45-50

Documentation searched other than minimum documentation to the extent that such documents are included in the fields searched

Electronic data base consulted during the international search (name of data base and, where practicable, search terms used)

C. DOCUMENTS CONSIDERED TO BE RELEVANT

Category*	Citation of document, with indication, where appropriate, of the relevant passages	Relevant to claim No.
Y	US 5,980,517 A (GOUGH) 09 NOVEMBER 1999, ENTIRE DOCUMENT.	1-66N

Further documents are listed in the continuation of Box C. See patent family annex.

* Special categories of cited documents:	
"A" document defining the general state of the art which is not considered to be of particular relevance	"T" later document published after the international filing date or priority date and not in conflict with the application but cited to understand the principle or theory underlying the invention
"E" earlier document published on or after the international filing date	"X" document of particular relevance; the claimed invention cannot be considered novel or cannot be considered to involve an inventive step when the document is taken alone
"L" document which may throw doubts on priority claim(s) or which is cited to establish the publication date of another citation or other special reason (as specified)	"Y" document of particular relevance; the claimed invention cannot be considered to involve an inventive step when the document is combined with one or more other such documents, such combination being obvious to a person skilled in the art
"O" document referring to an oral disclosure, use, exhibition or other means	"&" document member of the same patent family
"P" document published prior to the international filing date but later than the priority date claimed	

Date of the actual completion of the international search
02 JANUARY 2002

Date of mailing of the international search report
10 JAN 2002

Name and mailing address of the ISA/US
Commissioner of Patents and Trademarks
Box PCT
Washington, D.C. 20231
Facsimile No. (703) 305-3230

Authorized officer
ROSALIND KEARNEY
Telephone No. (703) 308-0858