



Europäisches Patentamt  
European Patent Office  
Office européen des brevets



(11) **EP 1 173 124 B1**

(12) **EUROPEAN PATENT SPECIFICATION**

(45) Date of publication and mention  
of the grant of the patent:  
**27.04.2005 Bulletin 2005/17**

(51) Int Cl.7: **A61F 9/007**

(21) Application number: **00923622.5**

(86) International application number:  
**PCT/US2000/011298**

(22) Date of filing: **26.04.2000**

(87) International publication number:  
**WO 2000/064393 (02.11.2000 Gazette 2000/44)**

(54) **SHUNT DEVICE AND METHOD FOR TREATING GLAUCOMA**

SHUNTEINRICHTUNG UND VERFAHREN ZUR GLAUKOMBEHANDLUNG

DISPOSITIF DE DERIVATION ET METHODE DE TRAITEMENT DU GLAUCOME

(84) Designated Contracting States:  
**AT BE CH CY DE DK ES FI FR GB GR IE IT LI LU  
MC NL PT SE**  
Designated Extension States:  
**AL LT LV MK RO SI**

• **Brown, Reay H.**  
**Atlanta, GA 30319 (US)**

(30) Priority: **26.04.1999 US 131030 P**

(74) Representative:  
**Weiss, Wolfgang, Dipl.-Chem. Dr. et al**  
**Weickmann & Weickmann**  
**Patentanwälte**  
**Postfach 86 08 20**  
**81635 München (DE)**

(43) Date of publication of application:  
**23.01.2002 Bulletin 2002/04**

(60) Divisional application:  
**04018732.0 / 1 477 146**

(56) References cited:  
**WO-A-00/13627**                    **DE-A- 19 840 047**  
**US-A- 3 788 327**                    **US-A- 4 037 604**  
**US-A- 4 750 901**                    **US-A- 5 073 163**  
**US-A- 5 372 577**

(73) Proprietor: **GMP VISION SOLUTIONS, INC.**  
**Ft.Lauderdale, Florida 33301 (US)**

(72) Inventors:  
• **Lynch, Mary G.**  
**Atlanta, GA 30319 (US)**

• **SPIEGEL DETLEV: 'Chirurgische  
Glaukomtherapie',**

**EP 1 173 124 B1**

Note: Within nine months from the publication of the mention of the grant of the European patent, any person may give notice to the European Patent Office of opposition to the European patent granted. Notice of opposition shall be filed in a written reasoned statement. It shall not be deemed to have been filed until the opposition fee has been paid. (Art. 99(1) European Patent Convention).

## Description

### Technical Field

**[0001]** The present invention is generally directed to a surgical treatment for glaucoma, and relates more particularly to a device for continuously decompressing elevated intraocular pressure in eyes affected by glaucoma by diverting aqueous humor from the anterior chamber of the eye into Schlemm's canal where post-operative patency can be maintained with an indwelling shunt which can be surgically placed to connect the canal with the anterior chamber.

### Background of the Invention

**[0002]** Glaucoma is a significant public health problem, because glaucoma is a major cause of blindness. The blindness that results from glaucoma involves both central and peripheral vision and has a major impact on an individual's ability to lead an independent life.

**[0003]** Glaucoma is an optic neuropathy (a disorder of the optic nerve) that usually occurs in the setting of an elevated intraocular pressure. The pressure within the eye increases and this is associated with changes in the appearance ("cupping") and function ("blind spots" in the visual field) of the optic nerve. If the pressure remains high enough for a long enough period of time, total vision loss occurs. High pressure develops in an eye because of an internal fluid imbalance.

**[0004]** The eye is a hollow structure that contains a clear fluid called "aqueous humor." Aqueous humor is formed in the posterior chamber of the eye by the ciliary body at a rate of about 2.5 microliters per minute. The fluid, which is made at a fairly constant rate, then passes around the lens, through the pupillary opening in the iris and into the anterior chamber of the eye. Once in the anterior chamber, the fluid drains out of the eye through two different routes. In the "uveoscleral" route, the fluid percolates between muscle fibers of the ciliary body. This route accounts for approximately ten percent of the aqueous outflow in humans. The primary pathway for aqueous outflow in humans is through the "canalicular" route that involves the trabecular meshwork and Schlemm's canal.

**[0005]** The trabecular meshwork and Schlemm's canal are located at the junction between the iris and the sclera. This junction or corner is called "the angle." The trabecular meshwork is a wedge-shaped structure that runs around the circumference of the eye. It is composed of collagen beams arranged in a three-dimensional sieve-like structure. The beams are lined with a monolayer of cells called trabecular cells. The spaces between the collagen beams are filled with an extracellular substance that is produced by the trabecular cells. These cells also produce enzymes that degrade the extracellular material. Schlemm's canal is adjacent to the trabecular meshwork. The outer wall of the trabecular

meshwork coincides with the inner wall of Schlemm's canal. Schlemm's canal is a tube-like structure that runs around the circumference of the cornea. In human adults, Schlemm's Canal is believed to be divided by septa into a series of autonomous, dead-end canals.

**[0006]** The aqueous fluid travels through the spaces between the trabecular beams, across the inner wall of Schlemm's canal into the canal, through a series of about 25 collecting channels that drain from Schlemm's canal and into the episcleral venous system. In a normal situation, aqueous production is equal to aqueous outflow and intraocular pressure remains fairly constant in the 15 to 21 mmHg range. In glaucoma, the resistance through the canalicular outflow system is abnormally high.

**[0007]** In primary open angle glaucoma, which is the most common form of glaucoma, the abnormal resistance is believed to be along the outer aspect of trabecular meshwork and the inner wall of Schlemm's canal. It is believed that an abnormal metabolism of the trabecular cells leads to an excessive build up of extracellular materials or a build up of abnormally "stiff" materials in this area. Primary open angle glaucoma accounts for approximately eighty-five percent of all glaucoma. Other forms of glaucoma (such as angle closure glaucoma and secondary glaucomas) also involve decreased outflow through the canalicular pathway but the increased resistance is from other causes such as mechanical blockage, inflammatory debris, cellular blockage, etc.

**[0008]** With the increased resistance, the aqueous fluid builds up because it cannot exit fast enough. As the fluid builds up, the intraocular pressure (IOP) within the eye increases. The increased IOP compresses the axons in the optic nerve and also may compromise the vascular supply to the optic nerve. The optic nerve carries vision from the eye to the brain. Some optic nerves seem more susceptible to IOP than other eyes. While research is investigating ways to protect the nerve from an elevated pressure, the only therapeutic approach currently available in glaucoma is to reduce the intraocular pressure.

**[0009]** The clinical treatment of glaucoma is approached in a step-wise fashion. Medication often is the first treatment option. Administered either topically or orally, these medications work to either reduce aqueous production or they act to increase outflow. Currently available medications have many serious side effects including: congestive heart failure, respiratory distress, hypertension, depression, renal stones, aplastic anemia, sexual dysfunction and death. Compliance with medication is a major problem, with estimates that over half of glaucoma patients do not follow their correct dosing schedules.

**[0010]** When medication fails to adequately reduce the pressure, laser trabeculoplasty often is performed. In laser trabeculoplasty, thermal energy from a laser is applied to a number of noncontiguous spots in the trabecular meshwork. It is believed that the laser energy

stimulates the metabolism of the trabecular cells in some way, and changes the extracellular material in the trabecular meshwork. In approximately eighty percent of patients, aqueous outflow is enhanced and IOP decreases. However, the effect often is not long lasting and fifty percent of patients develop an elevated pressure within five years. The laser surgery is not usually repeatable. In addition, laser trabeculoplasty is not an effective treatment for primary open angle glaucoma in patients less than fifty years of age, nor is it effective for angle closure glaucoma and many secondary glaucomas.

**[0011]** If laser trabeculoplasty does not reduce the pressure enough, then filtering surgery is performed. With filtering surgery, a hole is made in the sclera and angle region. This hole allows the aqueous fluid to leave the eye through an alternate route.

**[0012]** The most commonly performed filtering procedure is a trabeculectomy. In a trabeculectomy, a posterior incision is made in the conjunctiva, the transparent tissue that covers the sclera. The conjunctiva is rolled forward, exposing the sclera at the limbus. A partial thickness scleral flap is made and dissected half-thickness into the cornea. The anterior chamber is entered beneath the scleral flap and a section of deep sclera and trabecular meshwork is excised. The scleral flap is loosely sewn back into place. The conjunctival incision is tightly closed. Post-operatively, the aqueous fluid passes through the hole, beneath the scleral flap and collects in an elevated space beneath the conjunctiva. The fluid then is either absorbed through blood vessels in the conjunctiva or traverses across the conjunctiva into the tear film.

**[0013]** Trabeculectomy is associated with many problems. Fibroblasts that are present in the episclera proliferate and migrate and can scar down the scleral flap. Failure from scarring may occur, particularly in children and young adults. Of eyes that have an initially successful trabeculectomy, eighty percent will fail from scarring within three to five years after surgery. To minimize fibrosis, surgeons now are applying antifibrotic agents such as mitomycin C (MMC) and 5-fluorouracil (5-FU) to the scleral flap at the time of surgery. The use of these agents has increased the success rate of trabeculectomy but also has increased the prevalence of hypotony. Hypotony is a problem that develops when aqueous flows out of the eye too fast. The eye pressure drops too low (usually less than 6.0 mmHg); the structure of the eye collapses and vision decreases.

**[0014]** Trabeculectomy creates a pathway for aqueous fluid to escape to the surface of the eye. At the same time, it creates a pathway for bacteria that normally live on the surface of the eye and eyelids to get into the eye. If this happens, an internal eye infection can occur called endophthalmitis. Endophthalmitis often leads to permanent and profound visual loss. Endophthalmitis can occur anytime after trabeculectomy. The risk increases with the thin blebs that develop after MMC and 5-FU. Another factor that contributes to infection is the place-

ment of a bleb. Eyes that have trabeculectomy performed inferiorly have about five times the risk of eye infection than eyes that have a superior bleb. Therefore, initial trabeculectomy is performed superiorly under the eyelid, in either the nasal or temporal quadrant.

**[0015]** In addition to scarring, hypotony and infection, there are other complications of trabeculectomy. The bleb can tear and lead to profound hypotony. The bleb can be irritating and can disrupt the normal tear film, leading to blurred vision. Patients with blebs generally cannot wear contact lenses. All of the complications from trabeculectomy stem from the fact that fluid is being diverted from inside the eye to the external surface of the eye.

**[0016]** When trabeculectomy doesn't successfully lower the eye pressure, the next surgical step often is an aqueous shunt device. An aqueous diversion device of the prior art is a silicone tube that is attached at one end to a plastic (polypropylene or other synthetic) plate. With an aqueous shunt device, an incision is made in the conjunctiva, exposing the sclera. The plastic plate is sewn to the surface of the eye posteriorly, usually over the equator. A full thickness hole is made into the eye at the limbus, usually with a needle. The tube is inserted into the eye through this hole. The external portion of the tube is covered with either donor sclera or pericardium. The conjunctiva is replaced and the incision is closed tightly.

**[0017]** With prior art aqueous diversion devices, aqueous drains out of the eye through the silicone tube to the surface of the eye. Deeper orbital tissues then absorb the fluid. The outside end of the tube is protected from fibroblasts and scarring by the plastic plate. Many complications are associated with aqueous shunt devices. A thickened wall of scar tissue that develops around the plastic plate offers some resistance to outflow and in many eyes limits the reduction in eye pressure. In some eyes, hypotony develops because the flow through the tube is not restricted. Many physicians tie an absorbable suture around the tube and wait for the suture to dissolve post-operatively at which time enough scar tissue has hopefully formed around the plate. Some devices contain a pressure-sensitive valve within the tube, although these valves may not function properly. The surgery involves operating in the posterior orbit and many patients develop an eye muscle imbalance and double vision post-operatively. With prior art aqueous shunt devices, a pathway is created for bacteria to get into the eye and endophthalmitis can potentially occur.

**[0018]** The prior art includes a number of such aqueous shunt devices, such as U.S. Patent No. 4,936,825 (providing a tubular shunt from the anterior chamber to the corneal surface for the treatment of glaucoma), U.S. Patent No. 5,127,901 (directed to a transscleral shunt from the anterior chamber to the subconjunctival space), U.S. Patent No. 5,180,362 (teaching a helical steel implant that is placed to provide drainage from the anterior chamber to the subconjunctival space), and U.

S. Patent No. 5,433,701 (generally teaching shunting from the anterior chamber to the scleral or conjunctival spaces).

**[0019]** In addition to the prior art aqueous shunt devices described above, other prior art devices for glaucoma surgery have used setons, or other porous, wick-like components to divert and convey excess aqueous from the anterior chamber to the exterior ocular surface. Examples include U.S. Patent Nos. 4,634,418 and 4,787,885 (teaching the surgical treatment of glaucoma using an implant that consists of a triangular seton (wick)), and U.S. Patent No. 4,946,436, (teaching the use of a porous device to shunt anterior chamber to sub-scleral space). These patents do not teach placement in Schlemm's canal.

**[0020]** Some prior art references for glaucoma management have been directed at Schlemm's canal, but these have not involved the placement of long-term, indwelling shunts. U.S. Patent No. 5,360,399 teaches the temporary placement of a plastic or steel tube with preformed curvature in Schlemm's canal with injection of a viscous material through the tube to hydraulically expand and hydrodissect the trabecular meshwork. The tube is removed from the canal following injection. Because the tube is directed outwardly from the eye for injection access, the intersection of the outflow element with the preformed curved element within Schlemm's canal is at about a 90 degree angle relative to the plane of the curvature, and 180 degrees away from the anterior chamber. Therefore, at no time does any portion of the '399 device communicate with the anterior chamber. Furthermore, relative to that portion within Schlemm's canal, this tube has a larger diameter injection cuff element, which serves as an adapter for irrigation. Therefore, this device is not adapted for shunting aqueous between the anterior chamber and Schlemm's canal.

**[0021]** Most of the problems that have developed with current glaucoma treatment devices and procedures have occurred because aqueous fluid is drained from inside of the eye to the surface of the eye. A need exists, then, for a more physiologic system to enhance the drainage of aqueous fluid from the anterior chamber into Schlemm's canal. In the vast majority of glaucoma patients, the resistance problem lies between Schlemm's canal and the anterior chamber. The canal itself, the collecting channels and the episcleral venous system all are intact. Enhancing aqueous flow directly into Schlemm's canal would minimize the scarring that usually occurs with external filtration procedure since the internal angle region is populated with a single line of non-proliferating trabecular cells. Enhancing aqueous flow directly into Schlemm's canal would minimize hypotony since the canal is part of the normal outflow system and is biologically engineered to handle the normal volume of aqueous humor. Enhancing aqueous flow directly into Schlemm's canal would eliminate complications such as endophthalmitis and leaks.

**[0022]** WO 98/23237 A discloses an aqueous humor

shunt device in accordance with the preamble of claims 1, 13 and 24. There, a straight microfistula tube is to be implanted in radial direction of the eye.

**[0023]** WO 00/13627 A as prior art in accordance with Art. 54(3) EPC discloses a curved fluid permeable tube member to be inserted into Schlemm's canal without aspect to be received in the anterior chamber of the eye.

### Summary of the Invention

**[0024]** The present invention is directed to a novel shunt device as defined in claim 1 for the treatment of glaucoma in which the shunt is placed to divert aqueous humor from the anterior chamber of the eye into Schlemm's canal. The present invention therefore facilitates the normal physiologic pathway for drainage of aqueous humor from the anterior chamber, rather than shunting to the sclera or another anatomic site as is done in most prior art shunt devices. The present invention is further directed to providing a permanent, indwelling shunt to provide increased egress of aqueous humor from the anterior chamber to Schlemm's canal for glaucoma management.

### Brief Description of the Drawings

#### **[0025]**

FIG. 1A is an illustration showing an overhead perspective view of one embodiment of the present invention, in which the inventive shunt is comprised of tubular elements extending bi-directionally within Schlemm's canal.

FIG. 1B is an overhead view of the embodiment of the present invention shown in FIG. 1A, with phantom lines detailing the internal communication between the lumens of the tubular elements comprising the inventive device.

FIG. 1C is an illustration showing an overhead perspective view of one embodiment of the present invention, in which the inventive shunt is comprised of mesh tubular elements extending bi-directionally within Schlemm's canal.

FIG. 1D is an illustration showing an overhead perspective view of a shunt comprised of solid, porous elements extending bi-directionally within Schlemm's canal and thus not in accordance with the present invention.

FIG. 1E is an overhead perspective view of another embodiment of the present invention, with phantom lines detailing the internal communication between the two proximal lumens and the single distal lumen of the inventive device.

FIG. 2 is an illustration showing another embodiment of the present invention, in which the inventive shunt is comprised of perforated tubular elements and with an angulated terminal aspect of the proximal portion.

FIG. 3A is an illustration showing a perspective of another shunt comprised of elements that are partially tubular and partially open in their configuration and thus not in accordance with the present invention.

FIG. 3B is an illustration showing a top view of the shunt in FIG. 3A, with phantom lines detailing the internal communication of the device.

FIG. 3C is an illustration showing a side view from the proximal end of the shunt in FIG. 3A.

FIG. 3D is an illustration showing a perspective of another shunt comprised of elements that are partially open and trough-like in their configuration and thus not in accordance with the present invention.

FIG. 4 is an illustration showing another shunt comprised of distal elements having wicking extensions at their terminal ends, and in which the proximal portion has a sealed, blunted tip with a portal continuous with the lumen of the proximal portion, oriented to face away from the iris when the device is implanted in Schlemm's canal and thus not in accordance with the present invention.

FIG. 5A is an illustration showing another illustrative shunt in which a portion of the device enters Schlemm's canal in only one direction and shunts fluid in a non-linear path from the anterior chamber.

FIG. 5B is an illustration showing an alternative shunt in which the entire shunt is placed within Schlemm's canal but contains a fenestration to maintain fluid egress of aqueous humor from the anterior chamber to Schlemm's canal.

FIG. 5C is an illustration showing a side view of one embodiment of the present invention, in which the inventive shunt is comprised of tubular elements, with a proximal portion extending towards the anterior chamber that is shorter relative to the distal portions which extend bi-directionally within Schlemm's canal.

FIG. 5D is an illustration showing an alternative shunt comprised of a partially open trough-like element which is placed within Schlemm's canal but contains a portal to maintain fluid egress of aqueous humor from the anterior chamber to Schlemm's canal.

FIG. 5E is an illustration showing an alternative shunt comprised of a solid, but porous wick-like element which is placed within Schlemm's canal

FIG. 6A is an illustration showing certain anatomic details of the human eye.

FIG. 6B is a cross-sectional illustration showing the anatomic relationships of the surgical placement of an exemplary embodiment of the present invention.

FIG. 6C is a cross-sectional illustration showing the anatomic relationships of the surgical placement of another exemplary embodiment of the present invention in which the proximal portion has an angulated terminal aspect with a sealed, blunted tip with a portal continuous with the lumen of the proximal portion, oriented to face away from the iris when the device is implanted in Schlemm's canal.

### Detailed Description of Present Invention

[0026] The present invention provides an aqueous humor shunt device as defined in claim 1 to divert aqueous humor in the eye from the anterior chamber into Schlemm's canal, in which the shunt device comprises a distal portion having at least one terminal aspect sized and shaped to be circumferentially received within a portion of Schlemm's canal, and a proximal portion having at least one terminal aspect sized and shaped to be received within the anterior chamber of the eye, wherein the device permits fluid communication between the proximal portion in the anterior chamber to the distal portion in Schlemm's canal. Fluid communication is facilitated by an aqueous humor directing channel in either the proximal or distal portions, as described below.

[0027] The present invention also provides embodiments of an inventive shunt comprising a body of bio-compatible material of a size and shape adapted to be at least partially circumferentially received within a portion of Schlemm's canal to divert aqueous humor from the anterior chamber of the human eye to and within Schlemm's canal, and wherein the body facilitates the passage of aqueous humor from the anterior chamber into Schlemm's canal.

[0028] The invention contemplates many different configurations for an aqueous humor directing channel, provided that each assists in channeling aqueous humor from the anterior chamber to Schlemm's canal, such as by providing a lumen or capillary action. For example, the aqueous humor directing channel can be a fully enclosed lumen or a partially enclosed lumen. The devices of the present invention can be constructed of a solid, matrix, mesh, fenestrated, or porous material, or combinations thereof.

[0029] Traditional glaucoma teaching states that Schlemm's canal in an adult is divided by septa into separate canals, rendering the complete passage of a suture

impossible. Preliminary studies on adult human eye bank eyes have shown that Schlemm's canal is, indeed, patent. A suture can be passed through the entire circumference of the canal. It has not been heretofore determined that Schlemm's canal is patent throughout its circumference in normal adult individuals, as opposed to being divided by septae into multiple dead end canals. The invention utilizes this knowledge to access Schlemm's canal and to create and maintain the natural physiologic egress of aqueous humor from the anterior chamber to Schlemm's canal and to the collecting channels.

**[0030]** In use the shunt devices divert aqueous humor from the anterior chamber of the eye into Schlemm's canal with a device that is implanted to extend from within the anterior chamber to Schlemm's canal. The portion of the device extending into Schlemm's canal can be fashioned from a flexible material capable of being received within a portion of the radius, curvature, and diameter of Schlemm's canal. All or parts of the device may be tubular, fenestrated, or pre-curved.

**[0031]** One embodiment of the present invention is illustrated in **FIG. 1A**, in which the shunt device **100** is shown in a side view. The shunt device **100** of this embodiment is comprised of two portions, a proximal portion **10** which joins a distal portion **25**. The proximal portion **10** and distal portion **25** shown create an enclosed tubular channeling structure. The total length of the distal portion **25** may be between about 1 and 40 mm, preferably about 6 mm. The same embodiment of the present invention is illustrated with phantom lines showing the internal fluid communication path in **FIG. 1B**. The lumen or channeling space defined by the walls of the proximal portion **10** and the distal portion(s) **25** are continuous at their junction at the distal portion portal **20**.

**[0032]** An alternate embodiment of the present invention is shown in **FIG. 1C**, in which the shunt device **100** is comprised of two luminal mesh elements, with a proximal portion **10** which joins a distal portion **25**. Yet another shunt not in accordance with the invention is shown in **FIG. 1D**, in which the shunt device **100** is comprised of two solid, porous elements which may provide wick-like fluid communication therethrough, with a proximal portion **10** which joins a distal portion **25**.

**[0033]** An alternate embodiment of the present invention is shown in **FIG. 1E**, in which the shunt device **100** is comprised of a proximal portion **10** having two lumens therein terminating in proximal portion portals **18**. The distal portion **25** shaped and sized to be received within Schlemm's canal extends in either direction having separate lumens traversing therethrough from each of the distal portion portals **20**.

**[0034]** Other examples of embodiments of the present invention are shown in **FIGS. 2** and **5C**. **FIG. 2** shows an embodiment of the inventive shunt in which the device **100** is tubular and fenestrated (**15, 30**) in its configuration, with an acute (<90°) angle of junction between the proximal portion **10** and the plane defined by

the distal portion **25**. Such fenestrations (**15, 30**) may be placed along any portion of the device **100** to facilitate the passage of fluid therethrough, but are particularly directed towards the collecting channels of the eye. **FIG. 2** further shows an alternate embodiment of the present invention in which the terminal aspect **16** of the proximal portion is angulated toward the iris **40** with respect to the main axis of the proximal portion **10**, with the portal **18** of the proximal portion directed toward from the iris **40**. In alternate embodiments as shown in **FIG. 6C**, the portal **18** of the proximal portion **16** is directed away from the iris **40**.

**[0035]** **FIG. 3A** shows a shunt in which a portion of the channeling device is enclosed and tubular in configuration at the junction of the proximal portion **10** and the distal portion **25**, but where the distal portion **10** is a trough-like channel. The distal portion portal **20** is also shown. The invention contemplates that any portion of the device **100** can be semi-tubular, open and trough-like, or a wick-like extension. Tubular channels can be round, ovoid, or any other enclosed geometry. Preferably the non-tubular trough-like aspects are oriented posteriorly on the outer wall of the canal to facilitate aqueous humor drainage to the collecting channels of the eye, as shown in **FIG. 3A**.

**[0036]** **FIG. 3B** shows an overhead view of the shunt of **FIG. 3A**, further detailing the relationship among the proximal portion **10** and the distal portion **25**. The aqueous humor directing channel is shown in dashed lines. **FIG. 3C** shows a proximal view of the shunt of **FIG. 3A**, further detailing the relationship among the proximal portion **10** and the distal portion **25**.

**[0037]** **FIG. 3D** shows another shunt in which the structure of the device **100** comprises an aqueous humor directing channel that is both open and curved in a continuous trough-like configuration along the proximal portion **10** and the distal portion **25**. The distal portion portal **20** is also an open trough-like channel.

**[0038]** **FIG. 4** shows another shunt with the addition of aqueous humor-wicking extensions **32** which are either continuous with, or attached to the terminal aspects of the distal portion **25**. The wicking extensions **32** can be fashioned from a monofilament or braided polymer, such as proline, and preferably have a length of 1.0 mm to 16.0 mm. Furthermore, the proximal portion **10** is curved with a sealed, blunted tip **16** and contains a portal **18** in fluid communication with the lumen of the proximal portion and oriented to face away from the iris when the shunt device **100** is implanted in its intended anatomic position. The shunt device **100** can also help to maintain the patency of Schlemm's canal in a stenting fashion.

**[0039]** **FIG. 5A** shows another shunt in which the proximal portion **10** joins a single, curved distal portion **25** in a "V-shaped," tubular configuration. The shunt shown in **FIG. 5A** can also have a portal (not shown) in the distal portion **25** adjacent to the junction with the proximal portion **10** in order to facilitate bi-directional flow of fluid within the canal. Fenestrations are contem-

plated in all embodiments of the invention, and these fenestrations may be round, ovoid, or other shapes as needed for optimum aqueous humor channeling function within the anatomic spaces involved.

[0040] FIG. 5B shows another shunt in which the body or device 100 comprises only a single, curved distal portion 25 which contains a distal portion portal 20 oriented towards the anterior chamber to allow egress of aqueous humor from the anterior chamber to Schlemm's canal. The body of this device can have a length of about 1.0 mm to 40 mm, preferably about 6 mm. The external diameter can be about 0.1 mm to 0.5 mm, or about 0.3 mm.

[0041] FIG. 5C shows another embodiment of the inventive shunt in which the device 100 comprises a bi-directional tubular distal portion 25 which is intersected by a proximal portion 10 which is short in length relative to the distal portion 25 and is directed towards the anterior chamber.

[0042] FIG. 5D shows still another shunt in which the device 100 comprises a bi-directional, trough-like, curved distal portion 25 for insertion into Schlemm's canal, which contains a distal portion portal 20 oriented to allow egress of aqueous humor from the anterior chamber, wherein the trough-like distal portion 25 is oriented to open toward the collecting channels to facilitate the egress of aqueous humor.

[0043] FIG. 5E shows another shunt in which the device 100 comprises a bi-directional, solid distal portion 25 for insertion into Schlemm's canal to facilitate the egress of aqueous humor from the canal to the collecting channels in a wicking capacity. The solid distal portion 25 can be porous or non-porous.

[0044] As the inventive device is an implant, it can be fabricated from a material that will be compatible with the tissues and fluids with which it is in contact. It is preferable that the device not be absorbed, corroded, or otherwise structurally compromised during its *in situ* tenure. Moreover, it is equally important that the eye tissues and the aqueous remain non-detrimentally affected by the presence of the implanted device. A number of materials are available to meet the engineering and medical specifications for the shunts. In the exemplary embodiments of the present invention, the shunt device 100 is constructed of a biologically inert, flexible material such as silicone or similar polymers. Alternate materials might include, but are not limited to, thin-walled Teflon, polypropylene, other polymers or plastics, metals, or some combination of these materials. The shunt device 100 may be constructed as either porous or solid in alternate embodiments. The material can contain a therapeutic agent deliverable to the adjacent tissues.

[0045] In the devices shown in FIGS. 1-4, the proximal portion 10 joins the distal portion(s) 25 at an angle sufficient to allow the placement of the proximal portion 10 within the anterior chamber of the eye when the distal portion 25 is oriented in the plane of Schlemm's canal. The proximal portion 10 is preferably of sufficient length,

about 0.1 to 3.0 mm or about 2.0 mm, to extend from its junction with the distal portion 25 in Schlemm's canal towards the adjacent space of the anterior chamber. While many geometries can be used for channeling aqueous humor, the diameter or width of the proximal portion 10 can be sized to yield an internal diameter of between about 0.1 and 0.5 mm, preferably 0.20 mm. for a tubular or curved shunt, or a comparable maximal width for a shunt with a multiangular configuration. In other devices, the proximal portion is a non-luminal, non-trough-like wicking extension that provides an aqueous humor directing channel along the length thereof.

[0046] Because the nature of the iris 40 is such that it tends to comprise a plurality of rather flaccid fimbriae of tissue, it is desirable to avoid said fimbriae from being drawn into the lumen of an implant, thus occluding the shunt device. Therefore, the proximal portion 10 may contain a plurality of fenestrations to allow fluid ingress, arranged to prevent occlusion by the adjacent iris. Alternately, the proximal portion 10 may comprise only a proximal portion portal 18 in the form of a fenestration oriented anteriorly to provide continuous fluid egress between the anterior chamber of the eye and the directing channel of the shunt. Said fenestrations may be any functional size, and circular or non-circular in various embodiments of the present invention. In addition, a porous structural material can assist in channeling aqueous humor, while minimizing the potential for intake of fimbriae.

[0047] Furthermore, the proximal portion 10 may be positioned sufficiently remote from the iris 40 to prevent interference therewith, such as by traversing a more anterior aspect of the trabecular meshwork into the peripheral corneal tissue. In yet another possible embodiment, as shown in FIG. 6C, the device 100 may comprise a proximal portion 10 in which the terminal aspect of said proximal portion 10 is curved or angled toward the iris 40, and with a blunted, sealed tip 16 and a portal 18 oriented anteriorly to face away from the underlying iris 40. Such a configuration would tend to decrease the possibility of occlusion of the shunt device by the iris 40.

[0048] The device 100 may contain one or more uni-directional valves to prevent backflow into the anterior chamber from Schlemm's canal. The internal lumen for an enclosed portion of the device or the internal channel defined by the edges of an open portion of the device communicates directly with the inner lumen or channel of the distal portion at the proximal portion portal 20.

[0049] The distal portion 25 may have a pre-formed curve to approximate the 6.0 mm radius of Schlemm's canal in a human eye. Such a pre-formed curvature is not required when flexible material is used to construct the shunt device 100. The distal portion 25 may be of sufficient length to extend from the junction with the proximal portion 10 through any length of the entire circumference of Schlemm's canal. Embodiments having a distal portion 25 that extends in either direction within

Schlemm's canal can extend in each direction about 1.0 mm to 20 mm, or about 3.0 mm, to permit circumferential placement through Schlemm's canal. The diameter or width of the distal portion **25** can be sized to yield an outer diameter of between about 0.1 and 0.5 mm, or about 0.3 mm, for a tubular or curved shunt, or a comparable maximal width for a shunt with a multiangular configuration. The distal portion **25** may contain a plurality of fenestrations to allow fluid egress, arranged to prevent occlusion by the adjacent walls of Schlemm's canal. In other embodiments, the distal portion is a non-luminal, non-trough-like wicking extension that provides an aqueous humor directing channel along the length thereof.

**[0050]** In the exemplary embodiments of the present invention, the shunt device may be either bi-directional, with the distal portion of the implant intersecting with the proximal portion in a "T-shaped" junction as shown in **FIGS. 1A-1C, 1E, 2, and 5C**. A bi-directional shunt device can have a distal portion that is threaded into opposing directions within Schlemm's canal. In the case of the uni-directional shunt, only the distal shunt portion is placed within Schlemm's canal. In these shunts, "non-linear fluid communication" means that at least some portion of the shunt through which fluid passes is not in a straight line. Examples of non-linear shunts are the above described bi-directional "T" shapes, and the uni-directional "V" shapes, or shunts having two channel openings which are not in straight alignment with each other.

**[0051]** The surgical anatomy relevant to the present invention is illustrated in **FIG. 6A**. Generally, **FIG. 6A** shows the anterior chamber **35**, Schlemm's canal **30**, the iris **40**, cornea **45**, trabecular meshwork **50**, collecting channels **55**, episcleral veins **60**, pupil **65**, and lens **70**. **FIG. 6B** illustrates the surgical placement of the exemplary embodiment of the present invention, with the relevant anatomic relationships. It should be noted that the inventive device is designed so that placement of the distal portion **25** within Schlemm's canal **30** results in an orientation of the proximal portion **10** within the anterior chamber **35** within the angle defined by the iris **40** and the inner surface of the cornea **45**. Therefore, if the plane defined by Schlemm's canal is defined as zero degrees, the proximal portion **10** can extend therefrom at an angle of between about +60 degrees towards the cornea **45** or -30 degrees toward the iris **40**, more preferably in the range of 0 to +45 degrees. This range may vary in individuals having a slightly different location of Schlemm's canal **30** relative to the limbal angle of the anterior chamber **35**.

**[0052]** In yet another embodiment of the present invention not shown, the shunt device **100** is configured with one distal portion **25** which is tubular to provide a shunting functionality and a plurality of proximal portions **10** which provide an anchoring function to stabilize the overall implant device, in addition to providing fluid communication from the anterior chamber to Schlemm's Ca-

nal.

**[0053]** The surgical procedure necessary to insert the device requires an approach through a conjunctival flap. A partial thickness scleral flap is then created and dissected half-thickness into clear cornea. The posterior aspect of Schlemm's canal is identified and the canal is entered posteriorly. The anterior chamber may be deepened with injection of a viscoelastic and a miotic agent. The proximal portion of the shunt is then inserted through the inner wall of Schlemm's canal and trabecular meshwork into the anterior chamber within the angle between the iris and the cornea. In some cases, an incision may be needed from Schlemm's canal through the trabecular meshwork into the anterior chamber to facilitate passage of the proximal portion therethrough. One arm of the distal portion of the shunt device is grasped and threaded into Schlemm's canal. In a similar fashion, the other arm of the distal portion of the shunt device (when present) is inserted into Schlemm's canal in the opposing direction from the first. The scleral flap and conjunctival wound are closed in a conventional manner.

**[0054]** While the above-described embodiments are exemplary, the invention contemplates a wide variety of shapes and configurations of the shunt to provide fluid communication between the anterior chamber and Schlemm's canal. The above-described embodiments are therefore not intended to be limiting to the scope of the claims.

## Claims

1. An aqueous humor shunt device to divert aqueous humor in an eye from the anterior chamber into Schlemm's canal, the shunt device (100) comprising a distal portion (25) having at least one terminal aspect shaped to be received within the Schlemm's canal and a tubular proximal portion (10) having at least one terminal aspect shaped to be received within the anterior chamber of the eye, wherein device (100) permits fluid communication from the proximal portion (10) in the anterior chamber to the distal portion (25) in Schlemm's canal, **characterized in that** the distal portion (25) is tubular to extend circumferentially within the Schlemm's canal, and **that** the tubular proximal portion (10) intersects the tubular distal portion (25), and the distal portion (25) branches in two opposite directions from the intersection with the proximal portion (10) permitting fluid communication in either direction along Schlemm's canal with the anterior chamber.
2. The shunt device of claim 1, wherein said distal portion (25) of the shunt (10) has an outer diameter of about 0.1 mm to 0.5 mm and a length of about 1

mm to 20 mm, and wherein said proximal portion (10) has a length of about 0.1 to 3 mm.

3. The shunt device of claim 1, wherein said distal portion (25) has a curve having a radius which approximates the radius of Schlemm's canal of a human eye, wherein the radius is between about 3 mm to 10 mm.
4. The shunt device of claim 1, wherein the shunt (100) is constructed of a biologically inert flexible material.
5. The shunt device of claim 1, wherein the proximal portion (10) of the shunt (100) intersects the distal portion (25) at about the midpoint of the length of the distal portion (25).
6. The shunt device of claim 1, wherein the distal portion (25) has a lumen (18) therethrough that allows the passage of fluid into Schlemm's canal.
7. The shunt device of claim 1, wherein the distal portion (25) has a plurality of fenestrations (30) therein that allow the passage of fluid into Schlemm's canal.
8. The shunt device of claim 1, wherein the proximal portion (10) has one or two lumens (18) therethrough leading fluid into the distal portion (25) of the shunt.
9. The shunt device of claim 1, wherein the proximal portion (10) has one or more fenestrations (15) therein that facilitate the passage of fluid into the distal portion (25) of the shunt.
10. The shunt device of claim 1, further comprising a plurality of proximal portions (10) intersecting the distal portion (25).
11. The shunt device of claim 1, wherein at least a portion of the distal portion (25) is selected from the group consisting of a round tubular channel and an ovoid tubular channel.
12. The shunt device of claim 1, wherein at least a portion of the device (100) is constructed from porous material.
13. The shunt device of claim 1, wherein the shunt device (100) is curved prior to insertion.
14. The shunt device of claim 1, wherein the shunt device permits bi-directional fluid flow within Schlemm's canal when inserted.
15. The shunt device of claim 1, wherein at least a portion of the device comprises a metal.

16. The shunt device of claim 1, 5, 8 or 14, wherein the shunt device is T-shaped.

## 5 Patentansprüche

1. Kammerwasser-Shuntvorrichtung um Kammerwasser in einem Auge von der Vorderkammer in den Schlemm-Kanal abzuleiten, wobei die Shuntvorrichtung (100) einen distalen Abschnitt (25), der mindestens eine terminale Seite aufweist die geformt ist um in dem Schlemm-Kanal aufgenommen zu werden und einen röhrenförmigen proximalen Abschnitt (10), der mindestens eine terminale Seite aufweist, die geformt ist um in der Vorderkammer des Auges aufgenommen zu werden, umfasst, wobei die Vorrichtung (100) eine Fluid-Kommunikation von dem proximalen Abschnitt (10) in der Vorderkammer zu dem distalen Abschnitt (25) im Schlemm-Kanal erlaubt, **dadurch gekennzeichnet, dass** der distale Abschnitt (25) röhrenförmig ist um sich umfänglich innerhalb des Schlemm-Kanals zu erstrecken, und **dass** der röhrenförmige proximale Abschnitt (10) den röhrenförmigen distalen Abschnitt (25) schneidet, und der distale Abschnitt (25) sich von dem Schnittpunkt mit dem proximalen Abschnitt (10) aus in zwei entgegengesetzte Richtungen verzweigt, sodass eine Fluid-Kommunikation in jede Richtung entlang des Schlemm-Kanals mit der Vorderkammer ermöglicht ist.
2. Shunt-Vorrichtung nach Anspruch 1, wobei der distale Abschnitt (25) des Shunts (10) einen äußeren Durchmesser von etwa 0,1 mm bis 0,5 mm und eine Länge von etwa 1 mm bis 20 mm aufweist, und wobei der proximale Abschnitt (10) eine Länge von etwa 0,1 bis 3 mm aufweist.
3. Shunt-Vorrichtung nach Anspruch 1, wobei der distale Abschnitt (25) eine Krümmung aufweist mit einem Radius der annähernd gleich dem Radius des Schlemm-Kanals eines menschlichen Auges ist, wobei der Radius zwischen etwa 3 mm und 10 mm liegt.
4. Shunt-Vorrichtung nach Anspruch 1, wobei der Shunt (100) aus einem biologisch inerten flexiblen Material ausgebildet ist.
5. Shunt-Vorrichtung nach Anspruch 1, wobei der proximale Abschnitt (10) des Shunts (100) den distalen Abschnitt (25) etwa in der Mitte der Länge des distalen Abschnitts (25) schneidet.
6. Shunt-Vorrichtung nach Anspruch 1, wobei der di-

stale Abschnitt (25) ein durch diesen verlaufendes Lumen (18) aufweist, das den Durchtritt von Fluid in den Schlemm-Kanal erlaubt.

7. Shunt-Vorrichtung nach Anspruch 1, wobei der distale Abschnitt (25) mehrere Fenster darin aufweist, die den Durchtritt von Fluid in den Schlemm-Kanal erlauben. 5
8. Shunt-Vorrichtung nach Anspruch 1, wobei der proximale Abschnitt (10) ein oder zwei durch diesen verlaufende Lumen (18) aufweist, welche Fluid in den distalen Abschnitt (25) des Shunts leiten. 10
9. Shunt-Vorrichtung nach Anspruch 1, wobei der proximale Abschnitt (10) ein oder mehrere Fenster (15) darin aufweist, die den Durchtritt von Fluid in den distalen Abschnitt (25) des Shunts unterstützen. 15
10. Shunt-Vorrichtung nach Anspruch 1, die ferner mehrere proximale Abschnitte (10) umfasst, die den distalen Abschnitt (25) schneiden. 20
11. Shunt-Vorrichtung nach Anspruch 1, wobei mindestens ein Abschnitt des distalen Abschnitts (25) ausgewählt ist aus der Gruppe bestehend aus einem runden röhrenförmigen Kanal und einem eiförmigen röhrenförmigen Kanal. 25
12. Shunt-Vorrichtung nach Anspruch 1, wobei mindestens ein Abschnitt der Vorrichtung (100) aus porösem Material ausgebildet ist. 30
13. Shunt-Vorrichtung nach Anspruch 1, wobei die Shunt-Vorrichtung (100) vor dem Einführen gekrümmt ist. 35
14. Shunt-Vorrichtung nach Anspruch 1, wobei die Shunt-Vorrichtung einen bidirektionalen Fluidfluss in dem Schlemm-Kanal erlaubt wenn sie eingefügt ist. 40
15. Shunt-Vorrichtung nach Anspruch 1, wobei mindestens ein Abschnitt der Vorrichtung ein Metall umfasst. 45
16. Shunt-Vorrichtung nach Anspruch 1, 5, 8 oder 14, wobei die Shunt-Vorrichtung T-förmig ist. 50

#### Revendications

1. Dispositif de dérivation d'humeur aqueuse pour dériver l'humeur aqueuse dans un oeil de la chambre antérieure dans le canal de Schlemm, le dispositif de dérivation (100) comprenant une portion distale (25) ayant au moins une extrémité formée pour être reçue dans le canal de Schlemm et une portion

proximale tubulaire (10) ayant au moins une extrémité formée pour être reçue dans la chambre antérieure de l'oeil, lequel dispositif (100) permet une communication de fluide de la portion proximale (10) dans la chambre antérieure à la portion distale (25) dans le canal de Schlemm,

#### caractérisé en ce que

la portion distale (25) est tubulaire pour s'étendre circonférentiellement dans le canal de Schlemm, et la portion proximale tubulaire (10) coupe la portion distale (25), et

la portion distale (25) se ramifie dans deux directions opposées à partir de l'intersection avec la portion proximale tubulaire (10) permettant une communication de fluide dans l'une ou l'autre direction le long du canal de Schlemm avec la chambre antérieure.

2. Dispositif de dérivation selon la revendication 1, dans lequel ladite portion distale (25) de la dérivation (100) a un diamètre extérieur d'environ 0,1 mm à 0,5 mm et une longueur d'environ 1 mm à 20 mm, et dans lequel ladite portion proximale (10) a une longueur d'environ 0,1 à 3 mm.
3. Dispositif de dérivation selon la revendication 1, dans lequel ladite portion distale (25) présente une courbure ayant un rayon qui s'approche du rayon du canal de Schlemm de l'oeil humain, dans lequel le rayon est entre environ 3 mm et 10 mm.
4. Dispositif de dérivation selon la revendication 1, dans lequel la dérivation (100) est constituée d'un matériau flexible biologiquement inerte.
5. Dispositif de dérivation selon la revendication 1, dans lequel la portion proximale (10) de la dérivation (100) coupe la portion distale (25) environ au milieu de la longueur de la portion distale (25).
6. Dispositif de dérivation selon la revendication 1, dans lequel la portion distale (25) a une lumière (18) à travers celle-ci qui autorise le passage du fluide dans le canal de Schlemm.
7. Dispositif de dérivation selon la revendication 1, dans lequel la portion distale (25) a une pluralité de fenestrations (30) dans celle-ci qui autorisent le passage du fluide dans le canal de Schlemm.
8. Dispositif de dérivation selon la revendication 1, dans lequel la portion proximale (10) a une ou deux lumières (18) à travers celle-ci conduisant le fluide dans la portion distale (25) de la dérivation.
9. Dispositif de dérivation selon la revendication 1, dans lequel la portion proximale (10) a une ou plusieurs fenestration(s) (15) dans celle-ci qui facilite

(nt) le passage du fluide dans la portion distale (25) de la dérivation.

10. Dispositif de dérivation selon la revendication 1, comprenant en outre une pluralité de portions proximales (10) coupant la portion distale (25). 5
11. Dispositif de dérivation selon la revendication 1, dans lequel au moins une portion de la portion distale (25) est choisie dans le groupe consistant en un canal tubulaire rond et un canal tubulaire ovoïde. 10
12. Dispositif de dérivation selon la revendication 1, dans lequel au moins une portion du dispositif (100) est constituée d'un matériau poreux. 15
13. Dispositif de dérivation selon la revendication 1, dans lequel le dispositif de dérivation (100) est incurvé avant l'insertion. 20
14. Dispositif de dérivation selon la revendication 1, dans lequel le dispositif de dérivation permet un flux bidirectionnel de fluide dans le canal de Schlemm lorsqu'il est inséré. 25
15. Dispositif de dérivation selon la revendication 1, dans lequel au moins une portion du dispositif comprend un métal.
16. Dispositif de dérivation selon la revendication 1, 5, 8 ou 14, dans lequel le dispositif de dérivation est en forme de T. 30

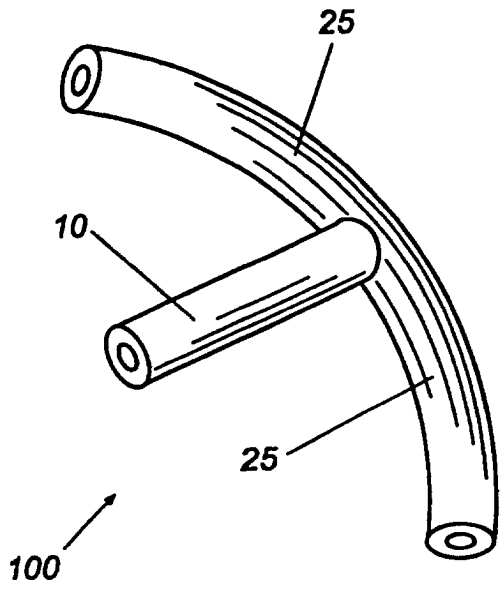
35

40

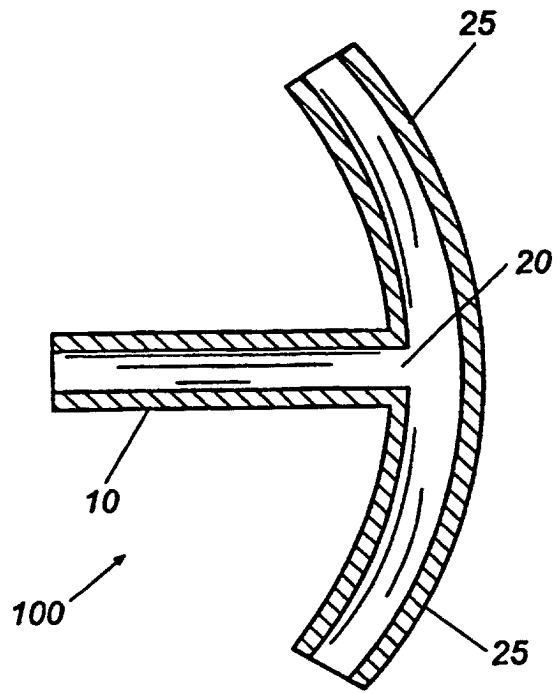
45

50

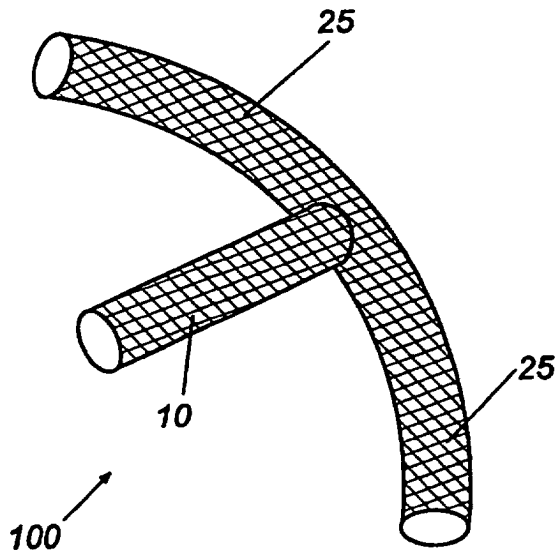
55



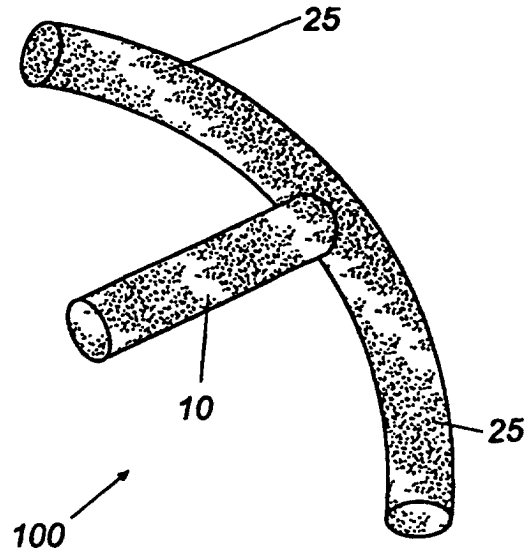
**Fig. 1A**



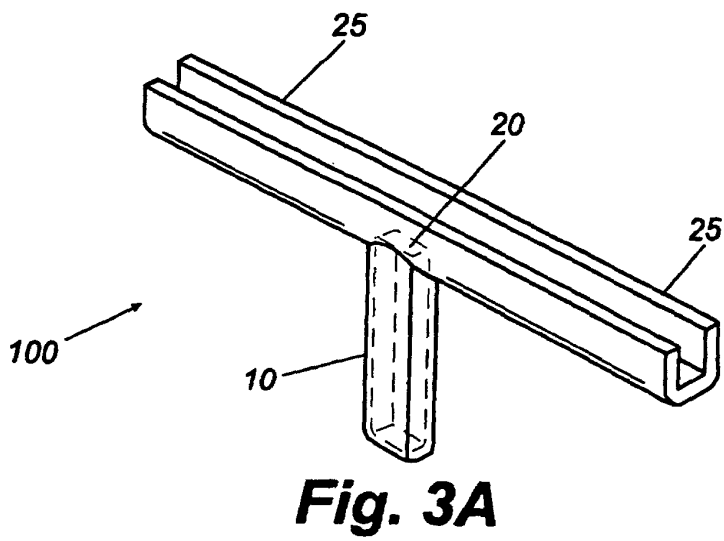
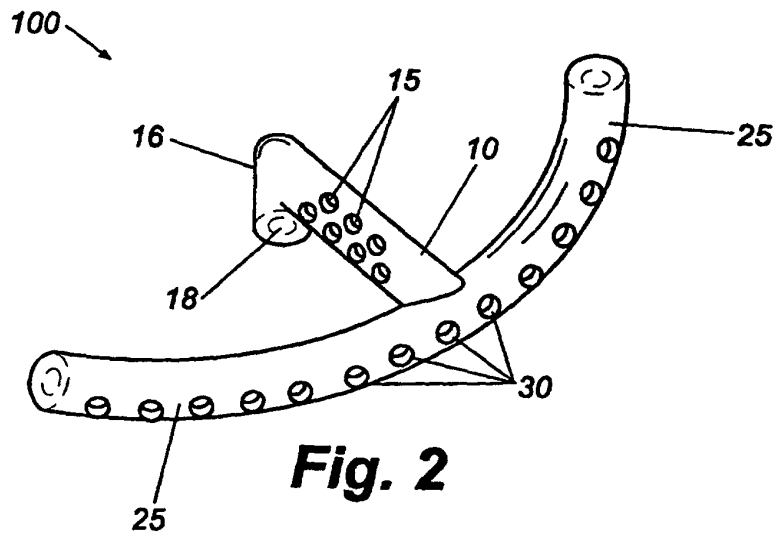
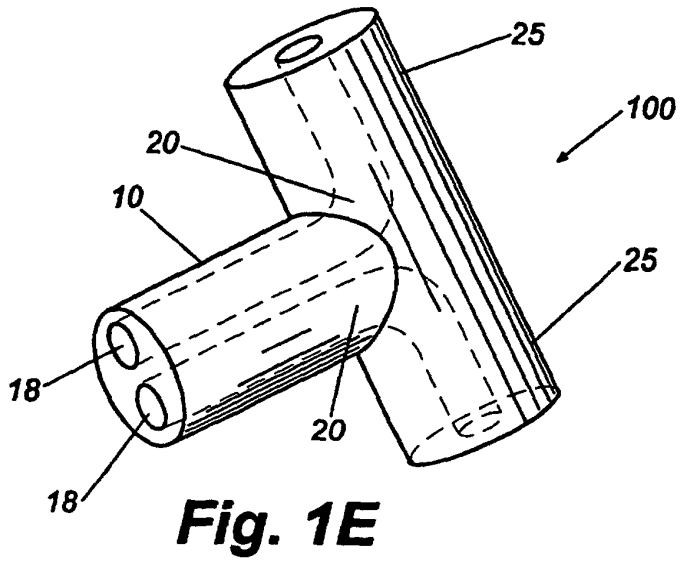
**Fig. 1B**

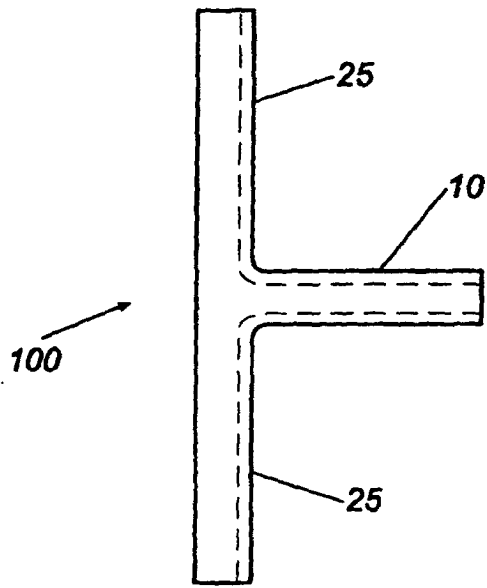


**Fig. 1C**

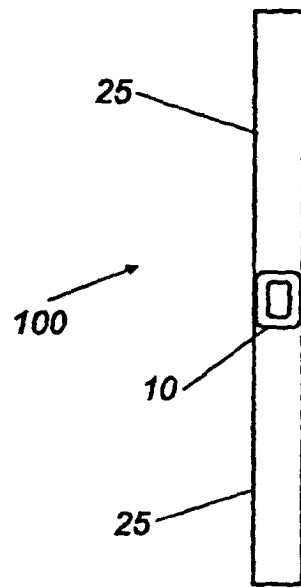


**Fig. 1D**

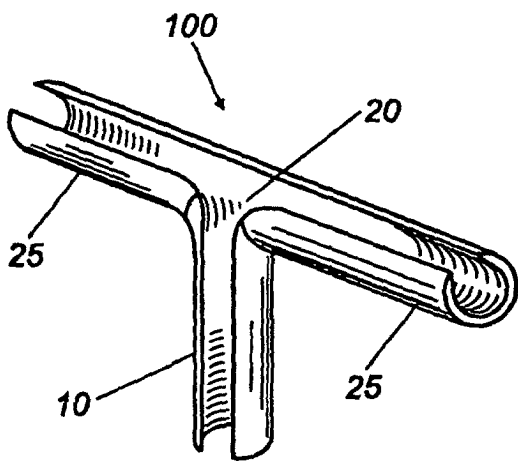




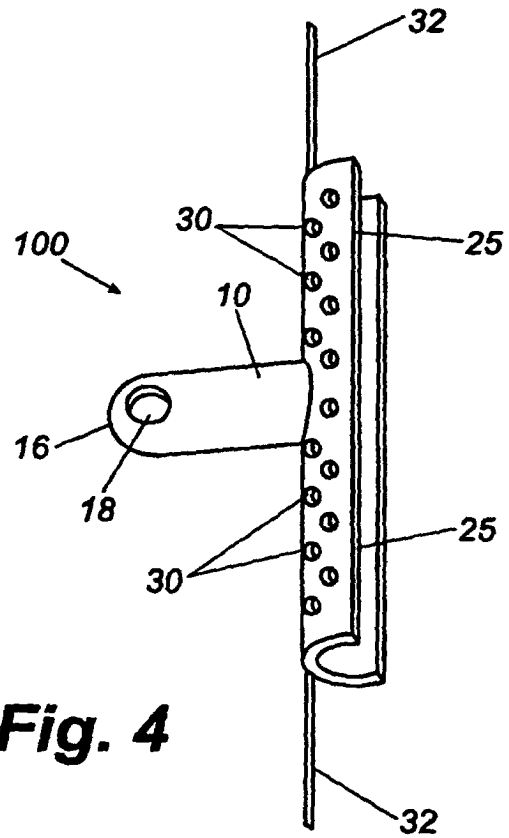
**Fig. 3B**



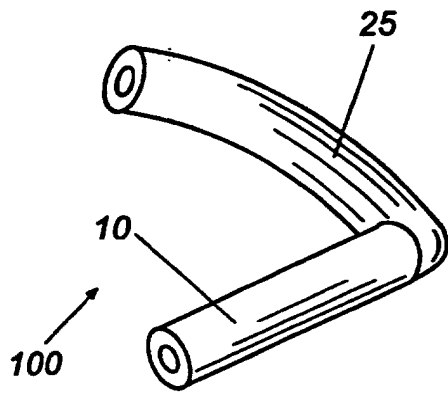
**Fig. 3C**



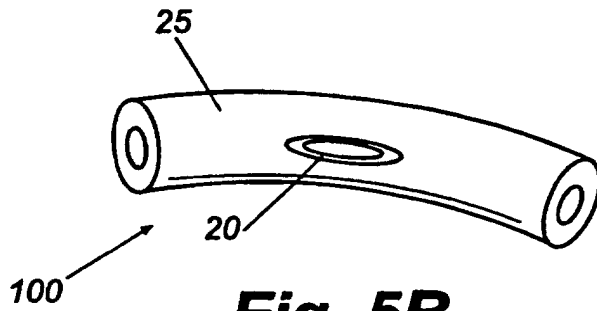
**Fig. 3D**



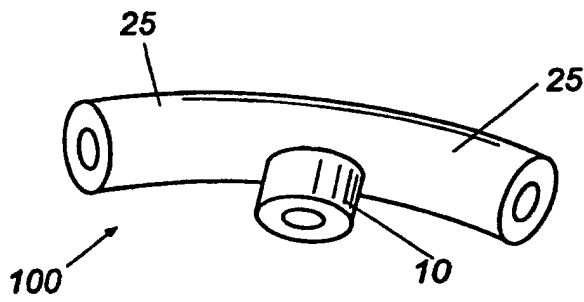
**Fig. 4**



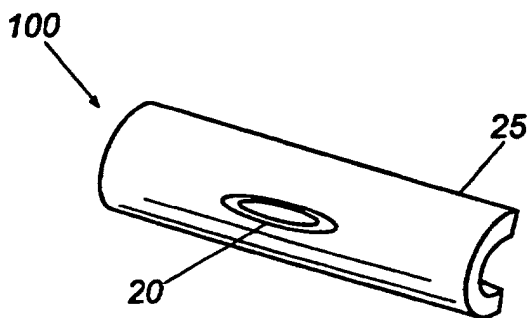
**Fig. 5A**



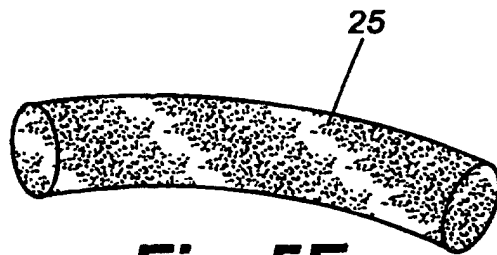
**Fig. 5B**



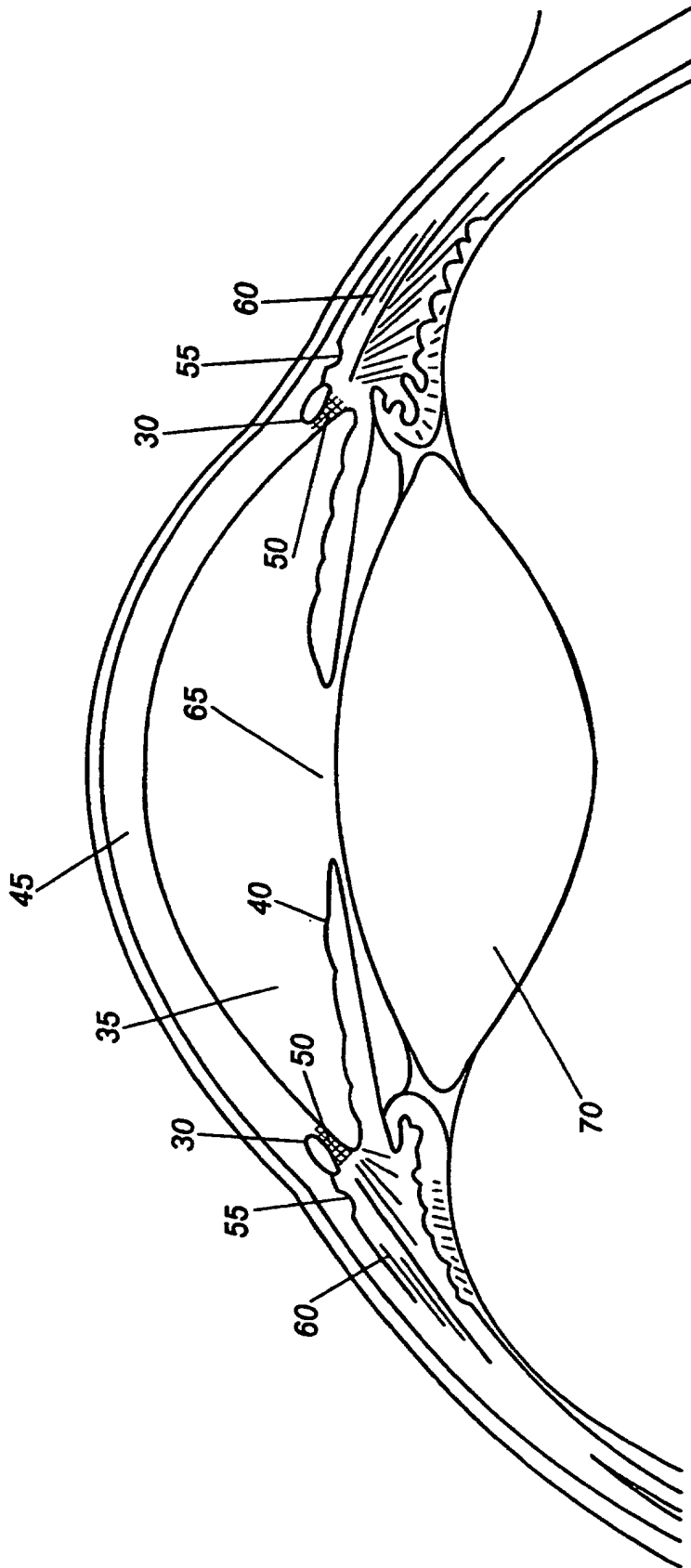
**Fig. 5C**



**Fig. 5D**



**Fig. 5E**



**Fig. 6A**

