



US00D778061S

(12) **United States Design Patent**  
**Fretwell et al.**

(10) **Patent No.:** **US D778,061 S**

(45) **Date of Patent:** **\*\* Feb. 7, 2017**

(54) **TOOTHBRUSH**

(71) Applicant: **GOSMILE, INC.**, Berkeley, CA (US)

(72) Inventors: **Allison Fretwell**, San Francisco, CA (US); **Lou Lentine**, Chattanooga, TN (US)

(73) Assignee: **GOSMILE, LLC.**, Austin, TX (US)

(\*\*) Term: **15 Years**

(21) Appl. No.: **29/531,104**

(22) Filed: **Jun. 23, 2015**

(51) **LOC (10) Cl.** ..... **04-02**

(52) **U.S. Cl.** ..... **D4/108**  
USPC ..... **D4/108**

(58) **Field of Classification Search**  
USPC ..... D4/100-102, 104-118, 124-125,  
D4/127-132, 136, 138

(Continued)

(56) **References Cited**

**U.S. PATENT DOCUMENTS**

D233,574 S \* 11/1974 Reitknecht ..... D4/108  
4,580,587 A \* 4/1986 Rittich ..... A46B 11/0027  
132/308

(Continued)

**FOREIGN PATENT DOCUMENTS**

AU 199479311 5/1995  
BR 10714858 A2 7/2009

(Continued)

**OTHER PUBLICATIONS**

Panasonic, Pocket Electric Toothbrush, posted at GadgetHim [online], posted on Oct. 20, 2010 [site visited Mar. 28, 2016]. Available from the Internet, <URL: <http://gadgethim.com/fun-toothbrush-designs/>>.\*

(Continued)

*Primary Examiner* — Catheri Oliver-Garcia

*Assistant Examiner* — Rebekah A Caruso

(74) *Attorney, Agent, or Firm* — Marshall, Gerstein & Borun LLP

(57) **CLAIM**

The ornamental design for a toothbrush, as shown and described.

**DESCRIPTION**

FIG. 1 is a front and right-side perspective view of the toothbrush design, showing the top cover in the open position and the bottom cover in the closed position.

FIG. 2 is a right-side view of the toothbrush thereof;

FIG. 3 is a left-side view of the toothbrush thereof;

FIG. 4 is a front view of the toothbrush thereof;

FIG. 5 is a rear view of the toothbrush thereof;

FIG. 6 is a top view of the toothbrush thereof;

FIG. 7 is a bottom view of the toothbrush thereof;

FIG. 8 is a front and right-side perspective view of the toothbrush, showing the top cover in the closed position and the bottom cover in the closed position.

FIG. 9 is a front view of the toothbrush thereof;

FIG. 10 is a rear view of the toothbrush thereof;

FIG. 11 is a left-side view of the toothbrush thereof;

FIG. 12 is a right-side view of the toothbrush thereof;

FIG. 13 is a top view of the toothbrush thereof;

FIG. 14 is a bottom view of the toothbrush thereof;

FIG. 15 is a bottom view of the toothbrush, showing the top cover in the closed position and the bottom cover in the open position.

FIG. 16 is a front and right-side exploded view of the toothbrush, showing the top cover in the open position and the bottom cover in the closed position.

FIG. 17 is a right-side exploded view of the toothbrush thereof;

FIG. 18 is a left-side exploded view of the toothbrush thereof;

FIG. 19 is a front exploded view of the toothbrush thereof;

FIG. 20 is a rear exploded view of the toothbrush thereof;

FIG. 21 is a top exploded view of the toothbrush thereof; and,

FIG. 22 is a bottom exploded view of the toothbrush thereof. The broken lines show elements of the toothbrush that form no part of the claimed design.

**1 Claim, 17 Drawing Sheets**

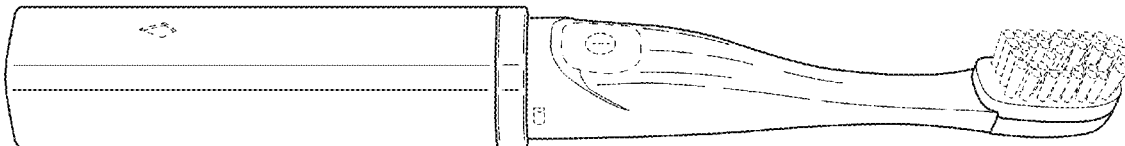
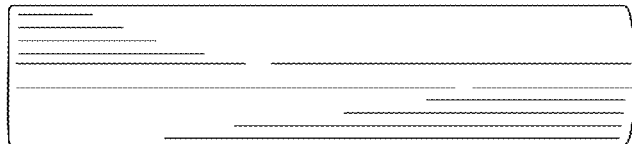

(58) **Field of Classification Search**  
 CPC ..... A46B 5/00; A46B 5/0004; A46B 5/0008;  
 A46B 5/0012; A46B 5/002; A46B 5/0095;  
 A46B 9/04; A46B 11/0006; A46B  
 2200/1066; A61B 17/24; A61C 17/16  
 See application file for complete search history.

(56) **References Cited**  
 U.S. PATENT DOCUMENTS

4,716,614 A 1/1988 Jones et al.  
 D303,733 S \* 10/1989 Benichou ..... D4/108  
 D318,375 S \* 7/1991 Bennett ..... D4/108  
 5,115,533 A 5/1992 Hukuba  
 D336,567 S \* 6/1993 Glover ..... D4/108  
 5,673,451 A 10/1997 Moore et al.  
 5,704,087 A 1/1998 Strub  
 5,737,792 A 4/1998 Quigless  
 5,813,855 A 9/1998 Crisio, Jr.  
 5,946,758 A 9/1999 Hohlbein et al.  
 D420,804 S 2/2000 Juhlin et al.  
 6,026,828 A 2/2000 Altshuler  
 6,154,912 A 12/2000 Li  
 D437,118 S \* 2/2001 Cheng ..... D4/108  
 D439,413 S \* 3/2001 Klein ..... D4/108  
 6,237,183 B1 5/2001 Fischer  
 D443,143 S \* 6/2001 Ponceano ..... D4/108  
 6,341,400 B1 1/2002 Kobayashi et al.  
 D464,489 S \* 10/2002 Emerick ..... D4/108  
 6,485,300 B1 11/2002 Muller et al.  
 D477,465 S 7/2003 Reilly et al.  
 6,616,451 B1 9/2003 Rizolu et al.  
 6,623,272 B2 9/2003 Clemans  
 6,752,627 B2 6/2004 Lin  
 6,862,771 B1 3/2005 Muller  
 6,902,397 B2 6/2005 Farrell et al.  
 6,926,532 B1 8/2005 Brattesani  
 6,954,961 B2 10/2005 Ferber et al.  
 7,134,162 B2 11/2006 Kweon et al.  
 7,261,558 B2 8/2007 Rizoïu et al.  
 7,328,708 B2 2/2008 Malak  
 D563,106 S 3/2008 Chan et al.  
 D565,843 S 4/2008 Mackintosh  
 7,422,598 B2 9/2008 Altshuler et al.  
 7,467,946 B2 12/2008 Rizoïu et al.  
 D614,868 S 5/2010 Goldman et al.  
 7,748,070 B2 7/2010 Chan et al.  
 7,975,344 B2 7/2011 Braun et al.  
 8,137,109 B2 3/2012 Gatzemeyer et al.  
 8,201,295 B2 6/2012 Gatzemeyer et al.  
 8,214,958 B2 7/2012 Pinyayev et al.  
 8,240,312 B2 8/2012 Feuerstein et al.  
 8,424,144 B2 4/2013 Nanda  
 8,429,783 B2 4/2013 Russell et al.  
 8,464,388 B2 6/2013 Chen  
 D687,226 S \* 8/2013 Doumoto ..... D4/101  
 D688,873 S \* 9/2013 Domoto ..... D4/101  
 D689,697 S \* 9/2013 Doumoto ..... D4/101  
 D698,555 S 2/2014 Nanda  
 D710,110 S \* 8/2014 Miller ..... D4/108  
 D723,282 S 3/2015 Fretwell et al.  
 D742,648 S 11/2015 Dishon  
 D753,922 S 4/2016 Jimenez et al.  
 2004/0155201 A1 8/2004 Russell et al.  
 2005/0064371 A1 3/2005 Soukos et al.  
 2005/0221251 A1 10/2005 Soukos et al.  
 2005/0267451 A1 12/2005 Black  
 2005/0271997 A1 12/2005 Mikami et al.  
 2006/0183071 A1 8/2006 Hsuch  
 2006/0222600 A1 10/2006 Pinyayev  
 2006/0223024 A1 10/2006 Hochman  
 2006/0283478 A1 12/2006 Avila et al.  
 2007/0111167 A1 5/2007 Russell et al.  
 2007/0131241 A1 6/2007 Nanda  
 2007/0143938 A1 6/2007 McDougall  
 2008/0060154 A1 3/2008 Jansheski  
 2008/0131834 A1 6/2008 Shepherd et al.

2008/0196184 A1 8/2008 Mary T.  
 2008/0286713 A1 11/2008 Nanda  
 2009/0148808 A1 6/2009 Alexander et al.  
 2009/0238778 A1 9/2009 Mordas et al.  
 2010/0043161 A1 2/2010 Tanuma  
 2011/0126370 A1 6/2011 Reuben  
 2011/0162155 A1 7/2011 Wai  
 2011/0277256 A1 11/2011 Jo et al.  
 2011/0296643 A1 12/2011 Shepherd et al.  
 2012/0096657 A1 4/2012 So et al.  
 2012/0137454 A1 6/2012 Huy et al.  
 2012/0258053 A1 10/2012 Patel et al.  
 2012/0270183 A1 10/2012 Patel et al.  
 2013/0117950 A1 5/2013 Kim

FOREIGN PATENT DOCUMENTS

CA 2603114 A1 10/2006  
 CN 2090244 U 12/1991  
 CN 2384592 Y 6/2000  
 CN 2779949 Y 5/2006  
 CN 2792296 Y 7/2006  
 CN 2838378 Y 11/2006  
 CN 2877417 Y 3/2007  
 CN 201319957 Y 10/2009  
 CN 201333107 Y 10/2009  
 CN 101606783 A 12/2009  
 CN 201393679 Y 2/2010  
 CN 201398630 Y 2/2010  
 CN 101683288 A 3/2010  
 CN 201468422 U 5/2010  
 CN 101856175 A 10/2010  
 CN 201755170 U 3/2011  
 CN 201790236 U 4/2011  
 CN 201790238 U 4/2011  
 CN 201798223 U 4/2011  
 CN 102121628 A 7/2011  
 CN 201899066 U 7/2011  
 CN 201905446 U 7/2011  
 CN 201977074 U 9/2011  
 CN 202146048 U 2/2012  
 CN 102379751 A 3/2012  
 CN 102429458 A 5/2012  
 CN 202286871 U 7/2012  
 CN 202341232 U 7/2012  
 CN 202375397 U 8/2012  
 CN 102793368 A 11/2012  
 CN 202515819 U 11/2012  
 CN 202526018 U 11/2012  
 CN 202526334 U 11/2012  
 CN 202552659 U 11/2012  
 CN 202552694 U 11/2012  
 CN 102813371 A 12/2012  
 CN 202637163 U 1/2013  
 DE 29908517 U1 12/1999  
 DE 202008006920 U1 9/2008  
 EP 1663058 A2 6/2006  
 EP 1664987 A2 6/2006  
 EP 2081542 A2 7/2009  
 EP 1792581 B1 3/2011  
 EP 1364594 B1 1/2012  
 JP 2241406 9/1990  
 JP 2277407 A 11/1990  
 JP 2003047528 A 2/2003  
 JP 2006068361 A 3/2006  
 JP 2011194181 A 10/2011  
 KR 280204 B1 1/2001  
 KR 2004013186 A 2/2004  
 KR 551710 B1 2/2006  
 KR 2007051986 A 5/2007  
 KR 2009022742 A 3/2009  
 KR 942722 B1 2/2010  
 KR 2010073065 7/2010  
 KR 20100079228 A 7/2010  
 KR 201100232 U 1/2011  
 KR 2011052843 A 5/2011  
 KR 1166065 B1 7/2012  
 KR 2012072505 A 7/2012  
 RU 2098993 C1 12/1997

(56)

**References Cited**

## FOREIGN PATENT DOCUMENTS

RU	2174381	C2	10/2001
RU	2183439	C2	6/2002
RU	2316243	C2	2/2008
RU	2375989	C1	12/2009
RU	104465	U	5/2011
TW	200425857	A	12/2004
TW	200950721	A	12/2009
WO	WO-95/10243	A1	4/1995
WO	WO-2005009270	A2	2/2005
WO	WO-2005/023145	A2	3/2005
WO	WO-2007102678	A1	9/2007
WO	WO-2008019870	A1	2/2008
WO	WO-2009047669	A2	4/2009
WO	WO-2009055943	A1	5/2009
WO	WO-2010127629	A1	11/2010
WO	WO-2013076535	A1	5/2013

## OTHER PUBLICATIONS

Go SMiLE, Go Sonic Whitening Toothbrush, posted at QVC [online], posting date not available [site visited Mar. 28, 2016]. Available from the Internet, <URL: [SMiLE-Set-of-2-On-the-Go-Sonic-Whitening-Toothbrushes.product.A270508.html>.\\*](http://www.qvc.com/GO-</a></p>
</div>
<div data-bbox=)

“Advanced Care: World’s First Toothbrush Featuring LED Self Sanitizing Technology on the Brush Head”, BriteBrushUSA, downloaded from the Internet at: <<http://www.britebrushusa.com/advancedcare.html>> (2011).

“UV Toothbrush” from Sharper Image website, downloaded from the Internet at: <<http://www.sharperimage.com/si/view/product/UV-Toothbrush/200770>> (2012).

Levenstein, LED Toothbrush Shines the Light On Dental Health, InventorSpot.com, downloaded from the Internet at: <[http://inventorspot.com/articles/led\\_toothbrush\\_shines\\_light\\_dental\\_health\\_34026](http://inventorspot.com/articles/led_toothbrush_shines_light_dental_health_34026)> (2009).

Osborne, “LED toothbrush could light the way to better dental health”, Geek.com, downloaded from the Internet at: <<http://www.geek.com/gadgets/led-toothbrush-could-light-the-way-to-better-dental-health-769892/>> (May 11, 2009).

Promedic Pro-Care LED Electric Toothbrush, Procure Co. Ltd., downloaded from the Internet at: <<http://procure21.m.ec21.com/mobile/productDetail.jsp?productId=7170686&groupId=7170662>>.

Yamamoto, “A toothbrush to light up your mouth”, cnet.com, downloaded from the Internet at: <<http://www.cnet.com/news/a-toothbrush-to-light-up-your-mouth/>> (Nov. 20, 2006).

\* cited by examiner

FIG. 1

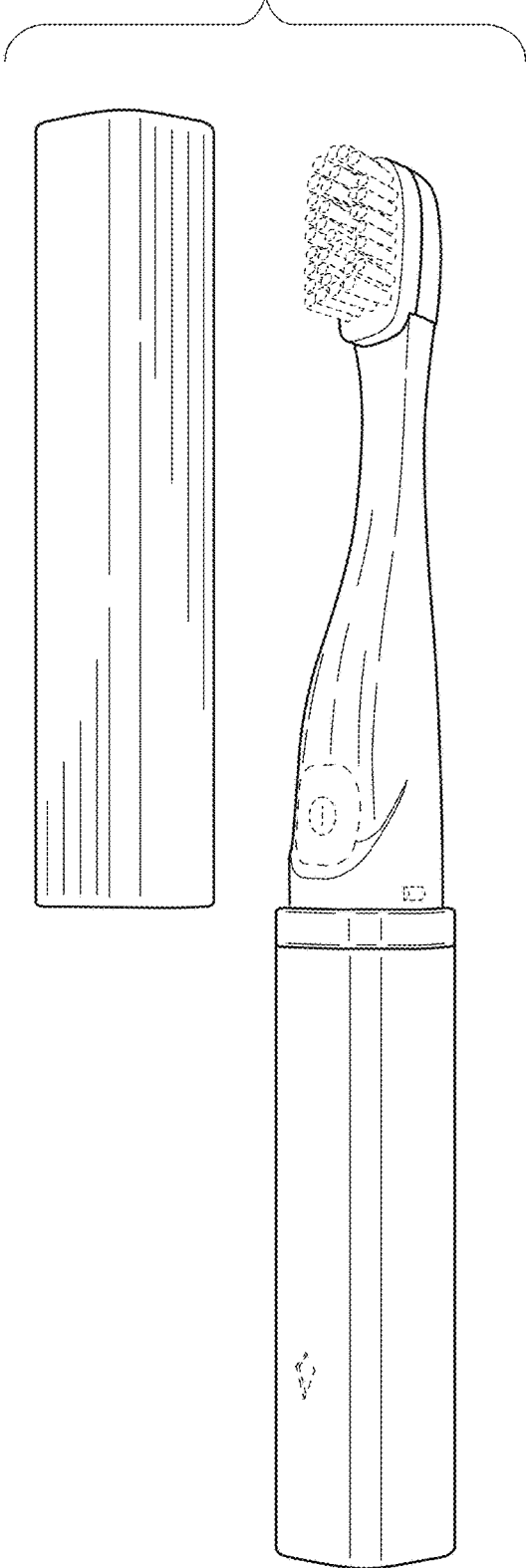

FIG. 2

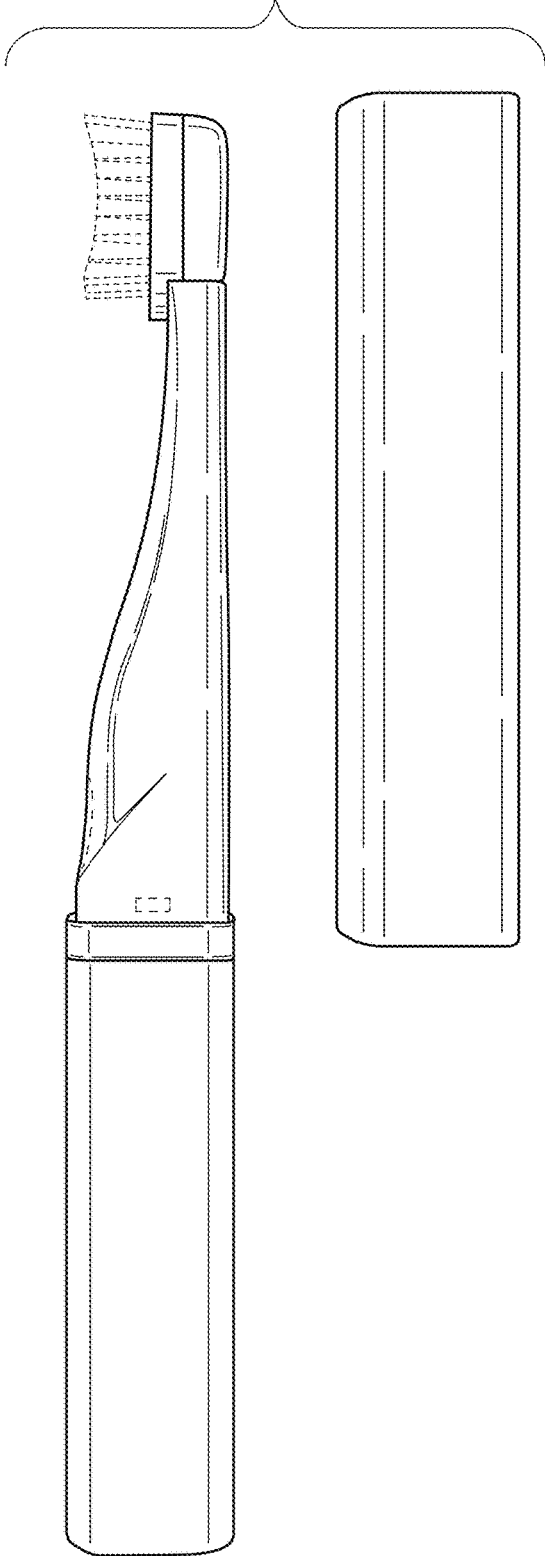

FIG. 3

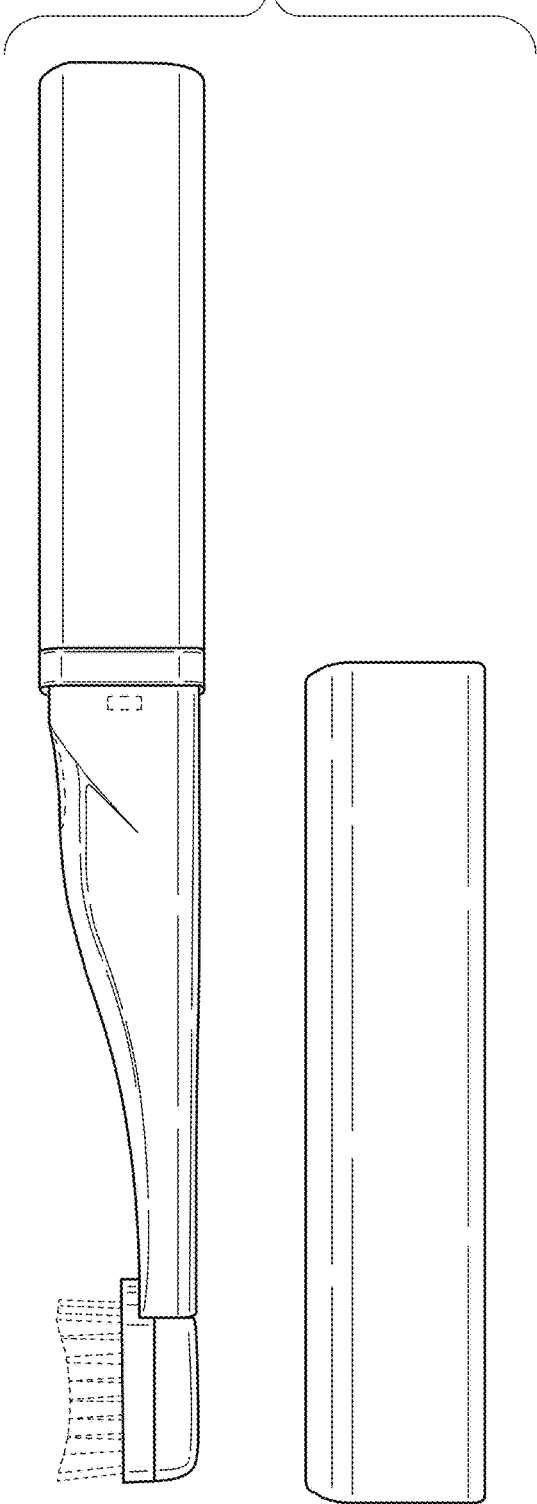

FIG. 4

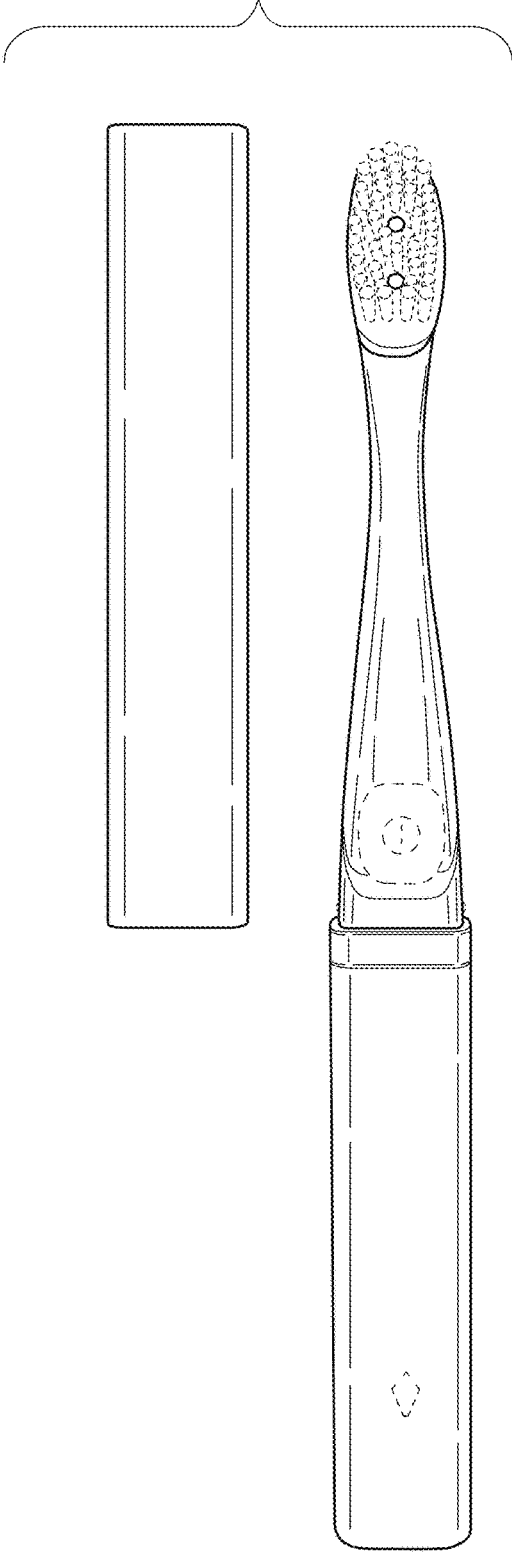
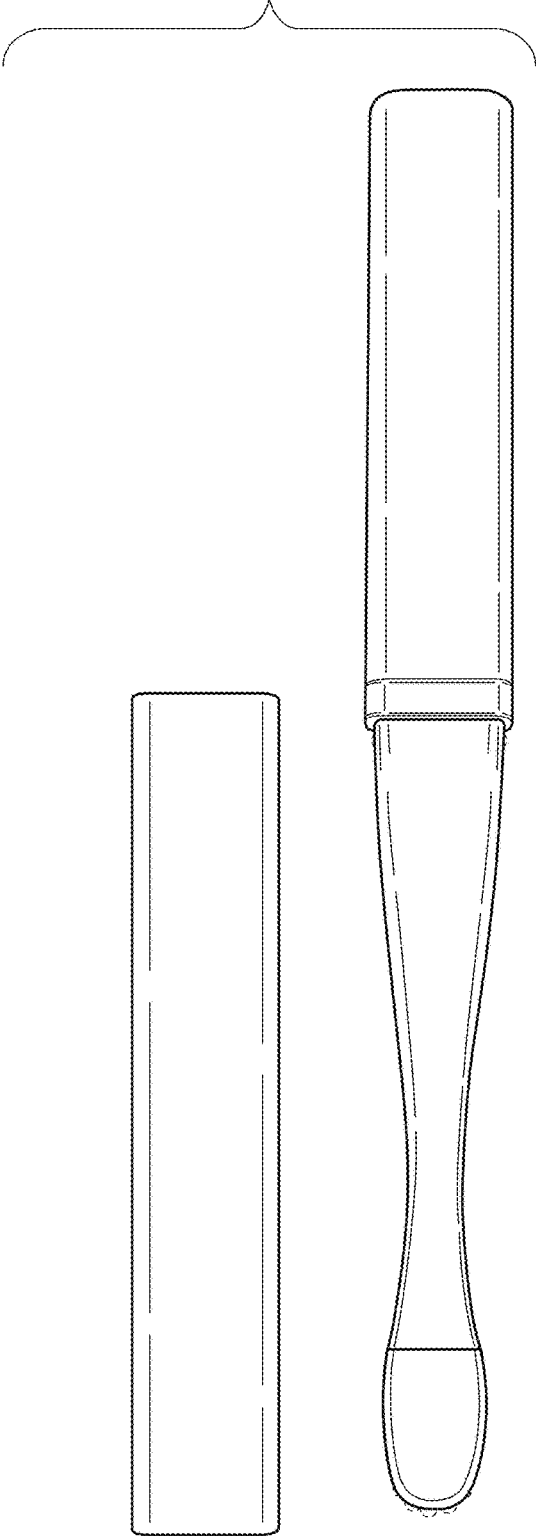
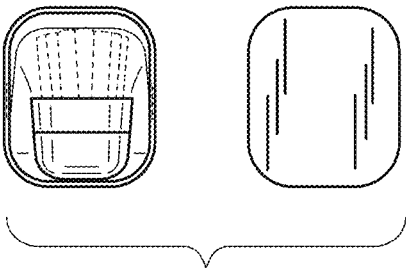

FIG. 5







**FIG. 6**

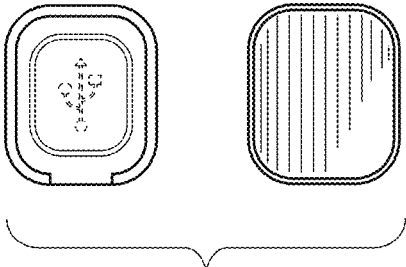

**FIG. 7**

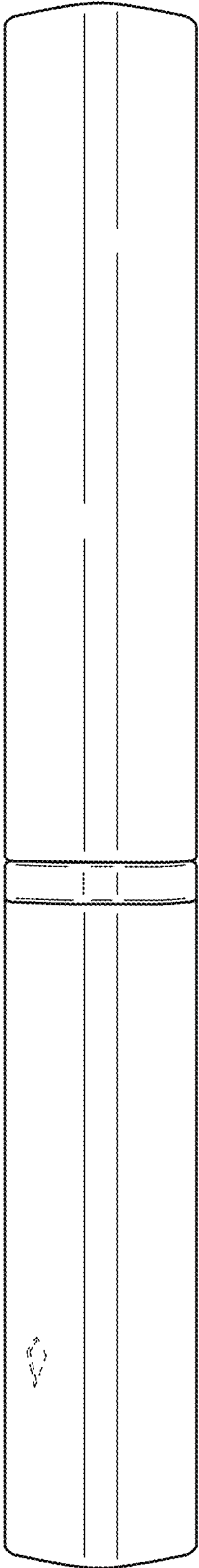
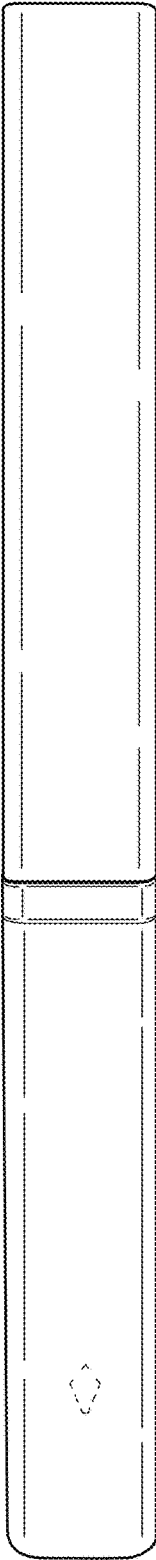

FIG. 8



**FIG. 9**



**FIG. 10**

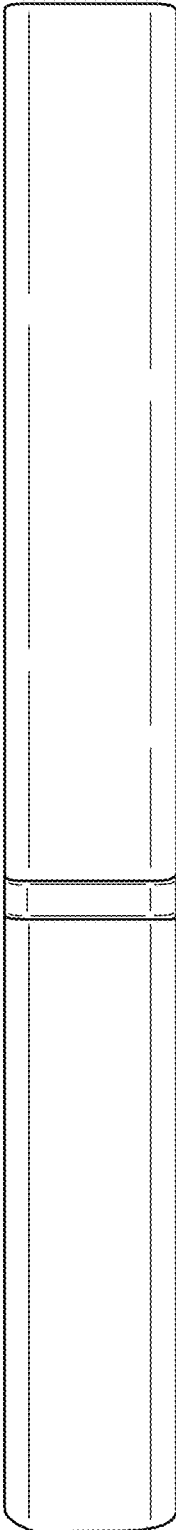

**FIG. 11**

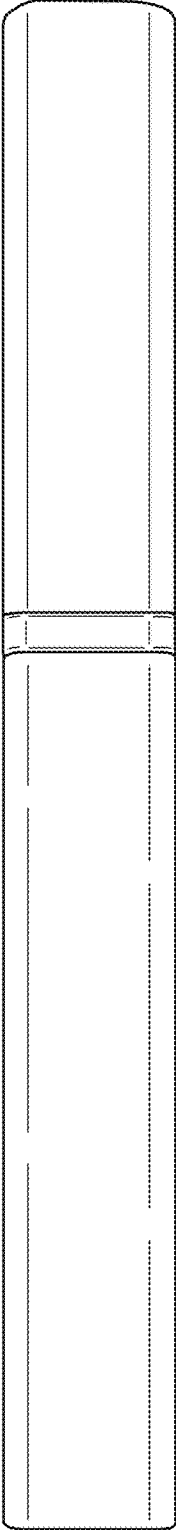

**FIG. 12**

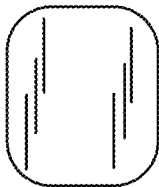

**FIG. 13**

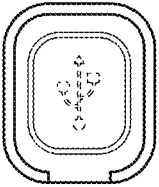

**FIG. 14**

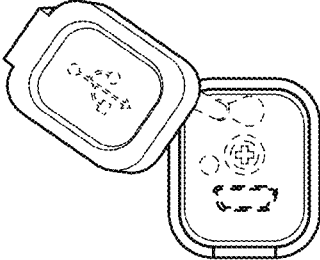

**FIG. 15**

FIG. 16

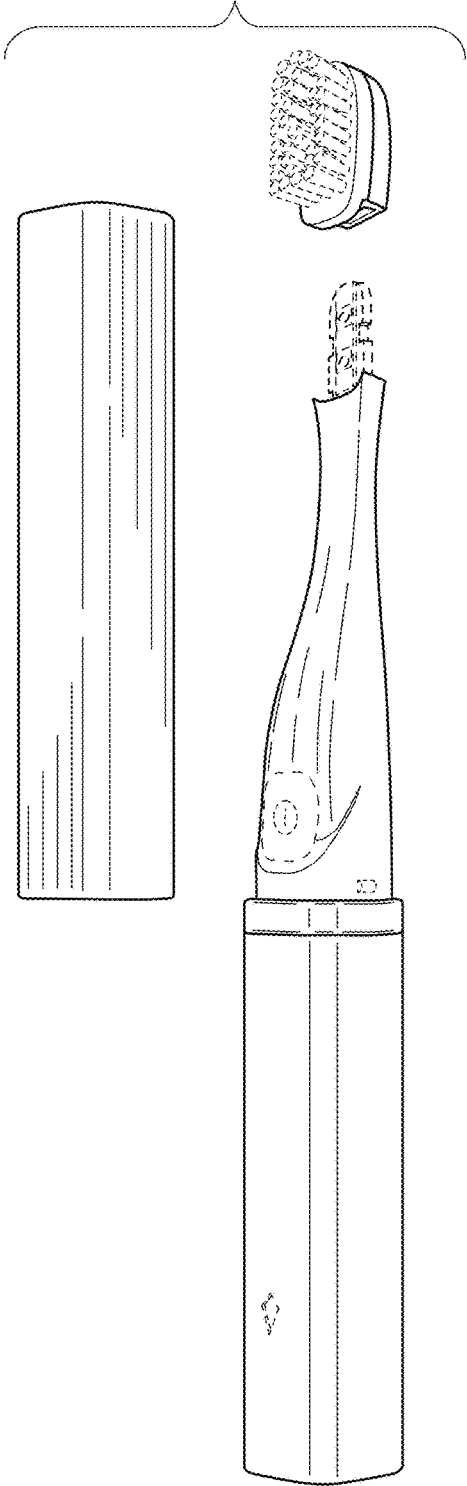

FIG. 17

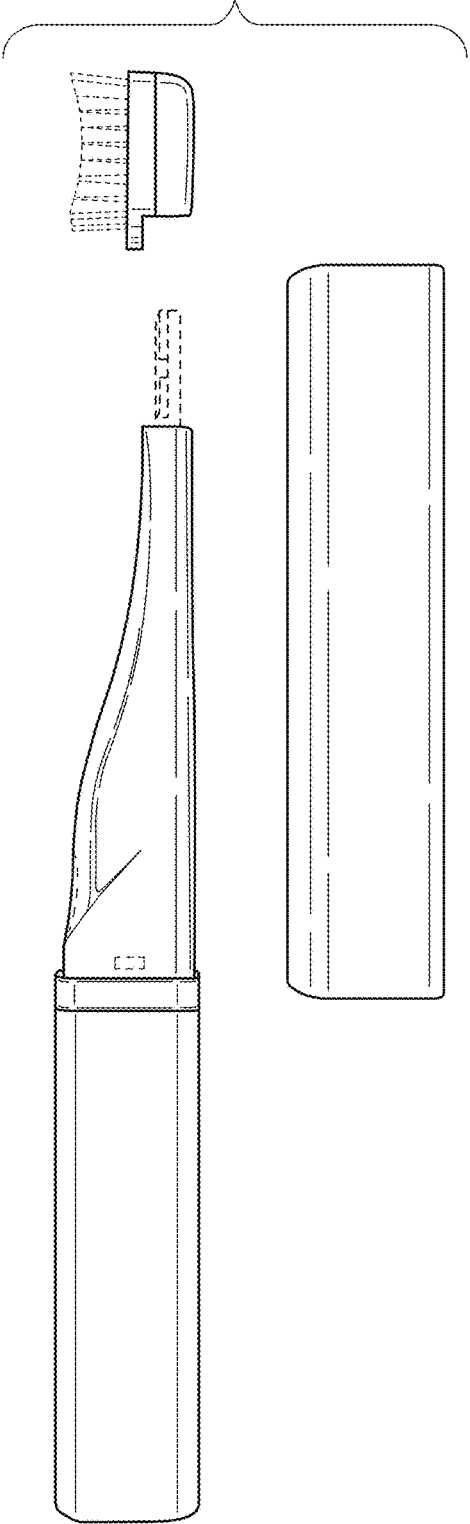



FIG. 18

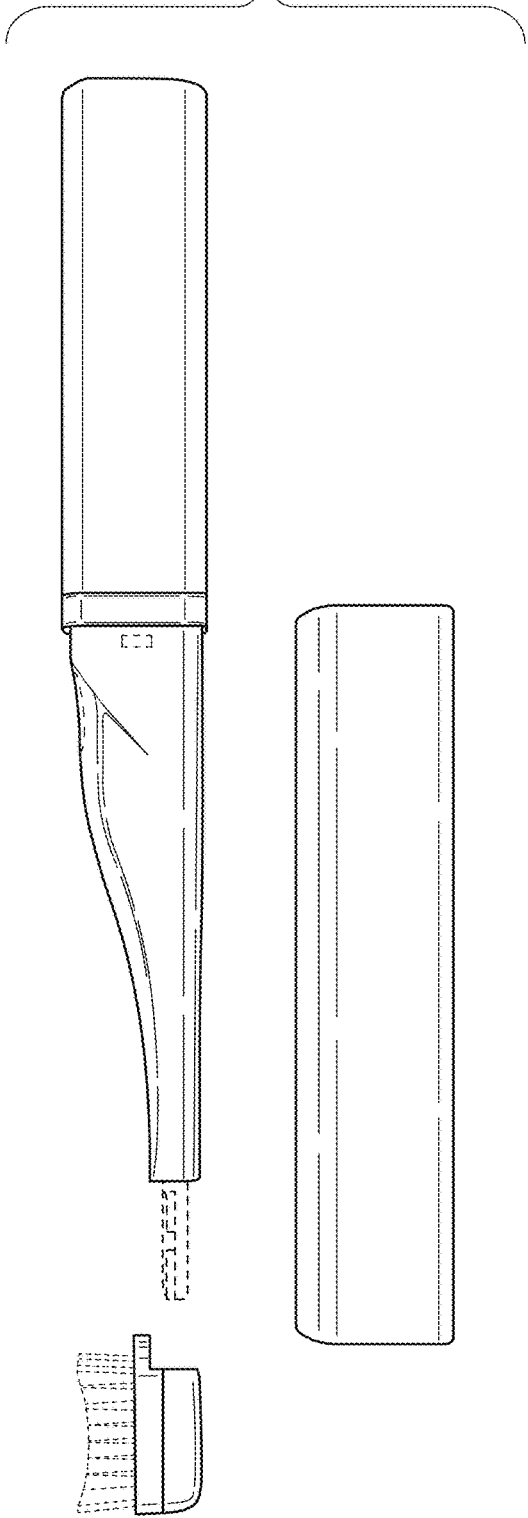

FIG. 19

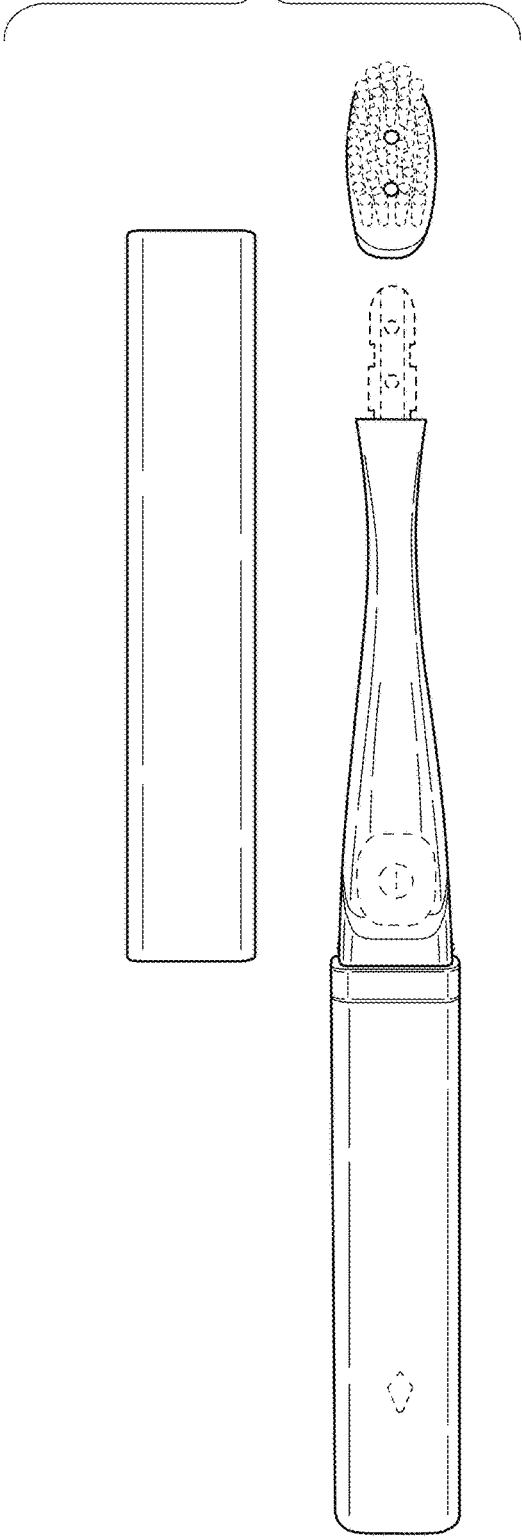
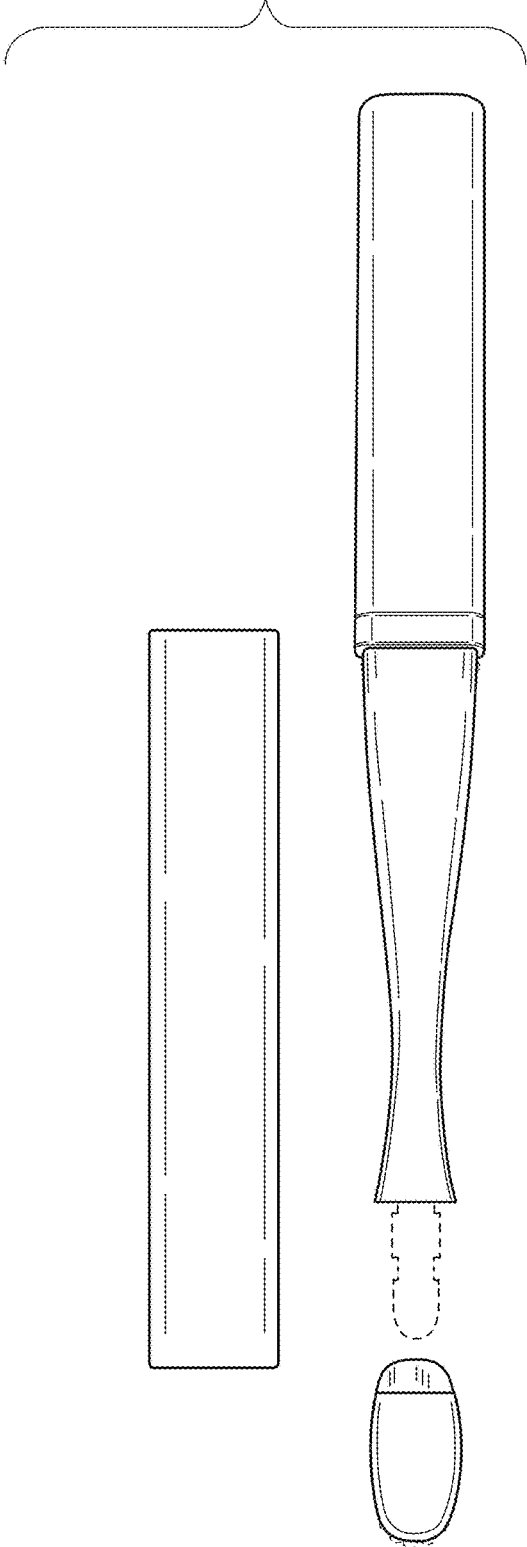
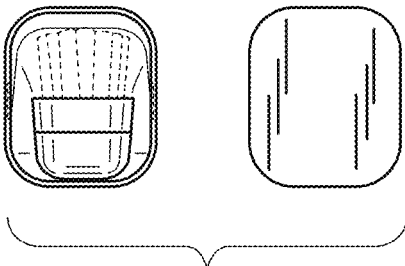
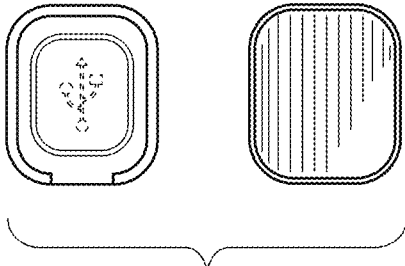

FIG. 20





**FIG. 21**



**FIG. 22**