

(No Model.)

G. THOMPSON.  
STOVE.

No. 540,468.

Patented June 4, 1895.

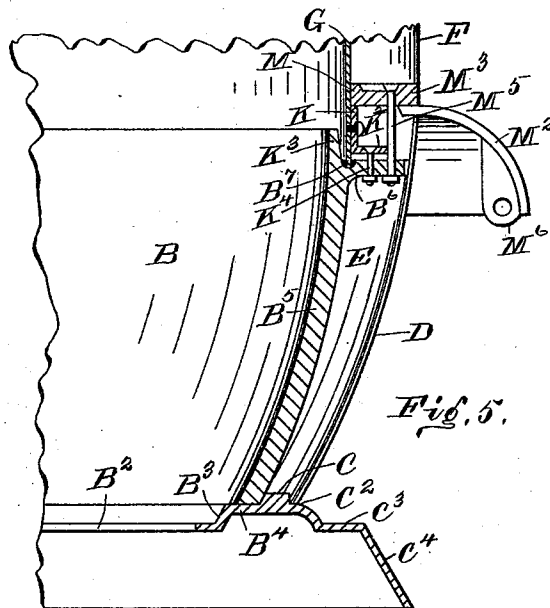
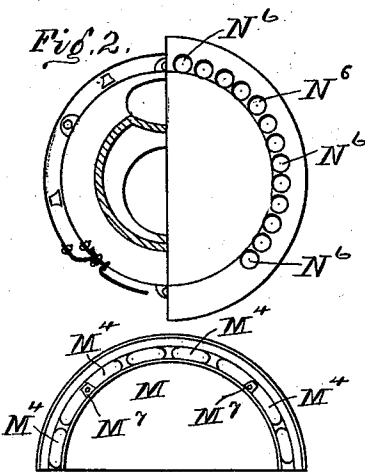
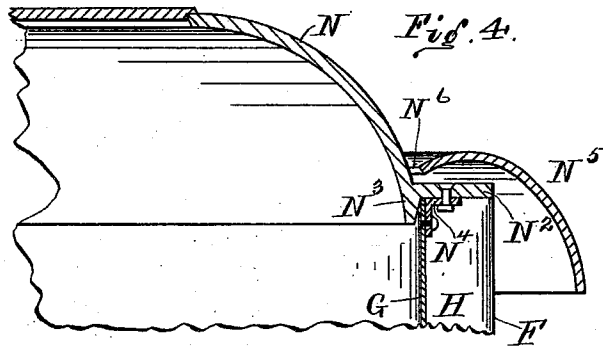
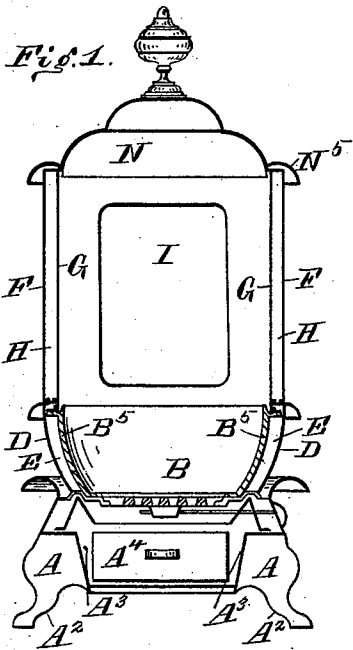

Witnesses  
*Wm E Jones*  
*N. Smith*

Inventor  
*George Thompson*  
Per *Jhm Hubbell Fisher*  
Attorney

# UNITED STATES PATENT OFFICE.

GEORGE THOMPSON, OF VINCENNES, INDIANA.

## STOVE.

SPECIFICATION forming part of Letters Patent No. 540,468, dated June 4, 1895.

Application filed October 29, 1894. Serial No. 527,168. (No model.)

*To all whom it may concern:*

Be it known that I, GEORGE THOMPSON, a citizen of the United States, and a resident of the city of Vincennes, in the county of Knox and State of Indiana, have invented certain new and useful Improvements in Stoves, of which the following is a specification.

The several features of my invention and the various advantages resulting from their use conjointly or otherwise, will be apparent from the following description and claims.

In the accompanying drawings, making a part of this application, and in which similar letters of reference indicate corresponding parts, Figure 1 represents a central vertical section of a stove embodying my invention. Fig. 2 is a compound view, to wit: The right-hand half of this figure represents a part of the true top of the stove, the ornamental superstructure being removed. In this right-hand portion is seen the one-half of a metallic perforated ring. The left-hand half of Fig. 2 indicates the top view of the main top. Fig. 3 represents a plan view of either half of the perforated middle ring. Fig. 4 represents a vertical transverse section of any side of the upper portion of the stove, and showing, among other things, the mode of joining the vertical drum and the upper or top part of the stove and the perforated nickel ring. Fig. 5 represents a vertical transverse section of the stove at and in the vicinity of the perforated middle ring, and also of the adjacent side of the fire-pot and the adjacent portion of the bottom of the latter.

The class of stoves to which my invention is applied is known as the radiating stove.

The base A of the stove is supported on legs A<sup>2</sup>, and is made of any suitable form to support the basal or foundation portion of the fire pot B. This base A preferably contains the ash pit A<sup>3</sup>, as shown, and the ash-pit contains the ash pan A<sup>4</sup> capable of being, at will, withdrawn from the stove, and emptied, and replaced in the stove.

The basal portion of the fire pot consists of the bottom B<sup>2</sup>, surrounded by a rising flange B<sup>3</sup>, joining an outwardly extending horizontal ring or surface B<sup>4</sup> terminating outwardly at the raised ring C. On the ring B<sup>4</sup>, and against the inner side of ring C, rests the lower edge of the vertical portion B<sup>5</sup> of the fire pot B.

The bottom B<sup>2</sup> has in it the usual grate, and consequent openings of any desired kind.

Outside of the ring C is a horizontal ledge C<sup>2</sup>, on which latter rests the foot or lower edge of the casing D, surrounding the fire pot B. There is a space E between the fire pot B and casing D.

Outside of the ledge C<sup>2</sup>, the basal portion of fire pot extends out and is carried down so as to rest in any proper manner upon the base or foundation A. One mode of thus extending said portion is shown in Figs. 1 and 5, and consists in the extension C<sup>3</sup>, C<sup>4</sup>, substantially as indicated.

The central or mid portion of the stove consists of two concentric drums, with a space H between. The outer drum F is preferably made of Russia iron, and the inner drum G of steel. In and through the sides of this drum is the door I, of any suitable size and kind.

The connection between the middle portion of the stove and the lower or fire pot portion will now be described.

A little below its upper edge and at its exterior, the fire pot B has a horizontal flange B<sup>6</sup> extending out to the casing D and forming a lateral support for the latter. The inner mid drum G rests upon this flange B<sup>6</sup>, its lower end fitting into a recess B<sup>7</sup> in the upper side of the flange next to the fire pot.

At the outer side of the lower portion of the drum G is a vertical ring K. This vertical ring K is riveted at K<sup>3</sup> to the drum G. Lugs or extensions K<sup>2</sup> extend horizontally outward. The location of the ring K, K<sup>2</sup> on the drum G is such that the lugs K<sup>2</sup> do not touch the flange B<sup>6</sup> of drum B<sup>5</sup>, but are located at a distance above it. The object of such location is to enable the securing bolts K<sup>4</sup> (which pass through the lugs K<sup>2</sup> and flange B<sup>6</sup>, to hold the ring K, K<sup>2</sup> to the flange B<sup>6</sup>) to tighten and draw down the ring and mid drum G so that the bottom of the latter rests securely in place in the groove B<sup>7</sup>. This effect could not be accomplished by these bolts if the lugs K<sup>2</sup> in the first instance and before being drawn upon by bolts K<sup>4</sup>, rested directly upon the flange B<sup>6</sup>. The flanges or lugs B<sup>6</sup> do not extend entirely across the space between the pot B<sup>5</sup> and the casing D, and ample room is given for the air heated between the fire pot B<sup>5</sup> and

the casing D to pass it or them and circulate upward into the space H between the mid drums G and F.

I will now describe the perforated middle ring M. This ring is located above the flange or lugs K<sup>2</sup>. Its inner edge rests upon the upper edge of the ring K. It extends out across the space H, and abuts against the inner side of the drum F forming at M<sup>3</sup> a lateral support for the latter. From the lower outer edge of this ring there extends outwardly a flange or extension M<sup>2</sup> which curves out and downwardly. On the top of this extension M<sup>2</sup> rests the drum F, and this extension M<sup>2</sup> in turn rests upon the upper edge of the casing D. The surface of the ring M between drums G and F and below space H is perforated at close intervals. These perforations M<sup>4</sup> (see Fig. 3) allow the air of the interspaces E and H to freely circulate. The ring M is held down securely in place by means of bolts as M<sup>5</sup>, connected at one end to the flange or a lug B<sup>6</sup> and at the other to the ring substantially as shown. These bolts go through the portions M<sup>7</sup> of the ring left between the perforations. The ring is made in two or more sections, and the several sections are bolted to one another end to end. A provision for thus uniting the sections is shown in Fig. 5, and consists of the flange M<sup>6</sup> projecting down from the end of the extension M<sup>2</sup> as shown, and perforated for the reception of a bolt securing said flange to a similar one of an adjacent section. This mid-securing device is wonderfully compact, simple, strong, economical of manufacture and readily put together, adjusted in position and readily taken apart for repair, &c.

The top N of the stove carries a series of horizontal lugs N<sup>2</sup>, extending outward from it and spanning the top of the space H between the drums G and F. These lugs rest on the top edges of the drums F and G. With the drum G and abutting against the inner side thereof is a down flange N<sup>3</sup>, projecting from the said top N. Angular corner irons or ring N<sup>4</sup> bolted to the outer side of the upper end of the drum and to the lugs N<sup>2</sup> hold the top N and drum G firmly together. The top N also carries the perforated ring N<sup>5</sup>, extending out and curved over and down. This ring is provided with perforations N<sup>6</sup> at comparatively close intervals all the way around it. The hot air passing up from spaces E and H passes up past the lugs N<sup>2</sup>, and in part passes out through the perforations N<sup>6</sup>. The hot air passing up along the outside of the outer mid drum F and close thereto, is caught under the curved ring N<sup>5</sup>. The most part of this air passes up through the perforations N<sup>6</sup> of ring N<sup>5</sup>.

While the various features of my invention are preferably employed together, one or more of such features may be used without the remainder, and in so far as applicable one or

more of said features may be employed in stoves other than the one herein specifically set forth.

What I claim as new and of my invention, and desire to secure by Letters Patent, is— 70

1. In a stove, the combination of the fire pot as B<sup>5</sup>, and a mid-inner drum G, and an outer mid-drum F, horizontal flange B<sup>6</sup> of the fire pot, supporting the lower end of drum G, angulated ring K, K<sup>2</sup>, perforated ring M<sup>3</sup> between drums G and F, and resting on ring K, K<sup>2</sup>, and bolted to flange B<sup>6</sup>, substantially as and for the purposes specified. 75

2. In a stove, the combination of the fire pot B<sup>5</sup>, having horizontal outward flange B<sup>6</sup>, and groove B<sup>7</sup> close to the pot, mid-drums G and F, and space H between, the drum G resting in the depression B<sup>7</sup>, and angulated ring K, K<sup>2</sup>, bolted to the drum and flange B<sup>6</sup>, perforated ring M<sup>3</sup> between drums G and F, and resting on ring K, K<sup>2</sup>, and bolted to flange B<sup>6</sup>, substantially as and for the purposes specified. 80 85

3. In a stove, the combination of the fire pot B<sup>5</sup> having horizontal outward flange B<sup>6</sup>, and groove B<sup>7</sup> close to the pot, mid-drums G and F, and space H between, the drum G resting in the depression B<sup>7</sup>, and angulated ring K, K<sup>2</sup>, bolted to the drum and flange B<sup>6</sup>, perforated ring M<sup>3</sup>, the flange K<sup>2</sup> being separated by a space from and above flange B<sup>6</sup>, substantially as and for the purposes specified. 90 95

4. In a stove, the combination of the fire pot B<sup>5</sup>, having horizontal flange B<sup>6</sup>, casing D and space E between the said pot and casing, and the mid-drums G and F, having interspace H, angulated ring K, K<sup>2</sup>, secured to the drum G, and flange B<sup>6</sup>, perforated ring M, having openings M<sup>4</sup>, and inter-parts M<sup>7</sup>, this ring M resting on the plate or ring K, K<sup>2</sup>, and on casing D, and bolted to flange B<sup>6</sup>, substantially as and for the purposes specified. 100 105

5. In a stove, the combination of the fire pot B<sup>5</sup>, having horizontal flange B<sup>6</sup>, casing D and space E between the said pot and casing, and the mid-drums G and F, having inter-space H, angulated ring K, K<sup>2</sup>, secured to the drum G, and flange B<sup>6</sup>, perforated ring M, having openings M<sup>4</sup>, and inter parts M<sup>7</sup>, this ring M resting on the plate or ring K, K<sup>2</sup>, and bolted to flange B<sup>6</sup>, and the curved deflecting ring M<sup>2</sup>, secured to ring M, and supported on the casing, substantially as and for the purposes specified. 110 115

6. In a stove, the combination of the fire pot B<sup>5</sup>, having horizontal flange B<sup>6</sup>, casing D and space E between the said pot and casing, and the mid-drums G and F, having inter-space H, angulated ring K, K<sup>2</sup>, secured to the drum G, and flange B<sup>6</sup>, perforated ring M, having openings M<sup>4</sup>, and inter parts M<sup>7</sup>, this ring M resting on the plate or ring K, K<sup>2</sup>, and bolted to flange B<sup>6</sup>, and the curved deflecting ring M<sup>2</sup>, secured to ring M, and supported on the casing, the latter made in sections and joined 120 125 130

by end partitions M<sup>6</sup> and bolts therethrough, substantially as and for the purposes specified.

7. In a stove, the combination of the fire pot 5 having flange B<sup>6</sup> and casing D, and mid-drums G and F, drum G being supported on flange B<sup>6</sup>, and the perforated ring M, between the casings G and F, and finally supported by the flange B<sup>6</sup>, substantially as and for the purposes 10 specified.

8. In a stove, the top N having horizontal perforated flange N<sup>2</sup>, mid-drums G and F with inter-space H, angular corner plate N<sup>4</sup>, securing drum G to flange N<sup>2</sup>, substantially as 15 and for the purposes specified.

9. In a stove, the top N having horizontal perforated flange N<sup>2</sup>, mid-drums G and F with inter space H, angular corner plate N<sup>4</sup>, securing drum G to flange N<sup>2</sup>, and the curved 20 perforated ring N<sup>5</sup>, extending out over and beyond drum F and downward, and having perforations N<sup>6</sup> in the vicinity of the top N and over space H, substantially as and for the purposes specified.

25 10. In a stove, the combination of the pot

B<sup>5</sup>, casing D, mid-drums with space E, drums G and F with space H, perforated ring M near the bottom of space H, in vertical line therewith, top N, perforated ring or flange N<sup>2</sup>, at top of space H, and guard deflector N<sup>5</sup> extending out beyond the casing F, and located 30 above the latter, and provided with perforations N<sup>6</sup> above space H, substantially as and for the purposes specified.

11. In a stove, the combination of the pot 35 B<sup>5</sup>, casing D, mid-drums with space E, drums G and F with space H, perforated ring M near the bottom of space H in vertical line therewith, annular ring M<sup>2</sup> extending from ring M and out beyond casing D, and the top N carrying guard deflector N<sup>5</sup> extending out beyond the casing F, and provided with perforations N<sup>6</sup> above space H, and flange N<sup>2</sup>, and connection for securing drum G in place, substantially as and for the purposes specified. 40

GEO. THOMPSON.

Attest:

HOMER M. BECKES,  
JOHN WILLMER.