

J. BAIRD.
STEAM BOILER.

No. 458,817.

Patented Sept. 1, 1891.

Fig. 2.

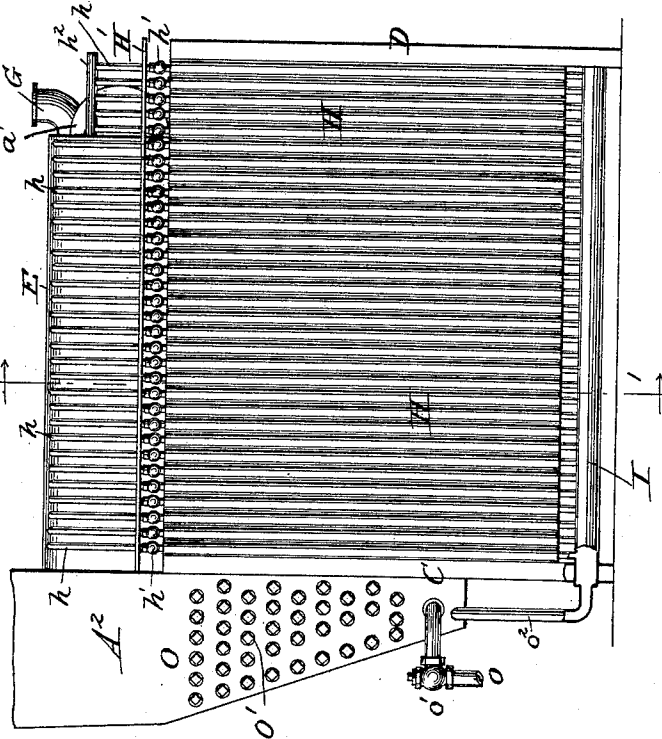
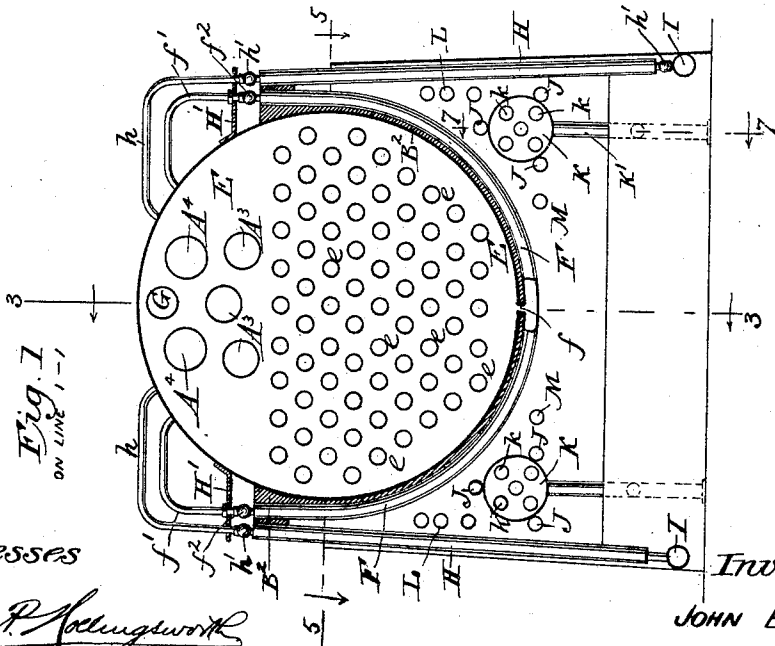

Fig. 1
ON LINE 1-1



Witnesses

Sidney P. Kelloggworth
Baltus DeLong

Inventor

JOHN BAIRD
by his attorneys

Baldwin, Davidson & Wright

J. BAIRD.
STEAM BOILER.

No. 458,817.

Patented Sept. 1, 1891.

Fig. 3

ON LINE 3-3

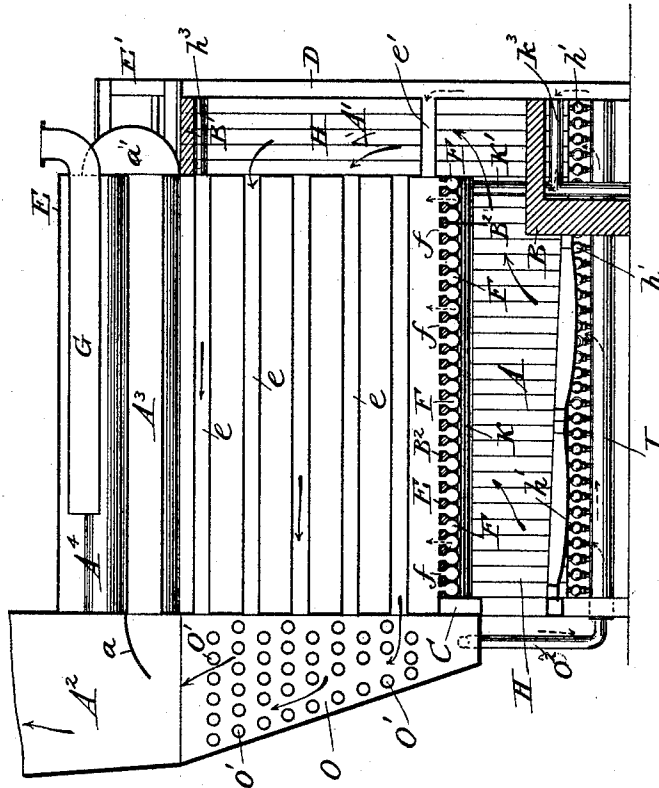

Witnesses
Shirley P. Hollingsworth
Baltus de Long.

Inventor
 JOHN BAIRD
 by his attorneys

Baldwin, Davidson & Wright

J. BAIRD.
STEAM BOILER.

No. 458,817.

Patented Sept. 1, 1891.

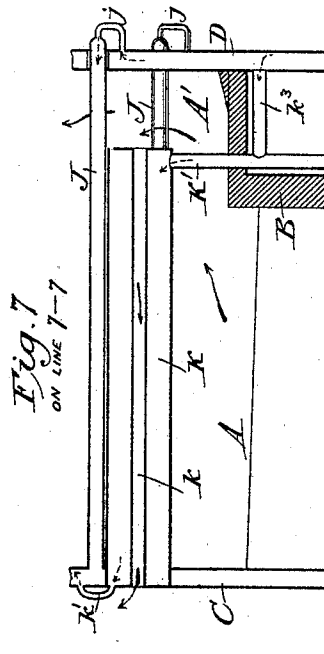
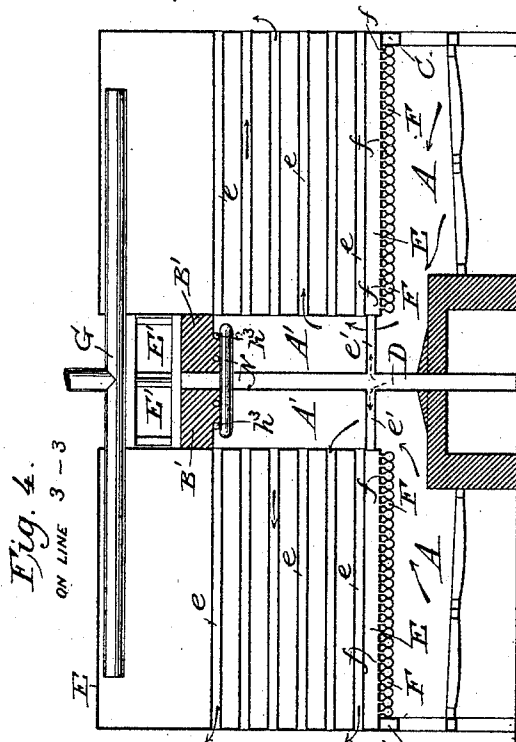

Fig. 6

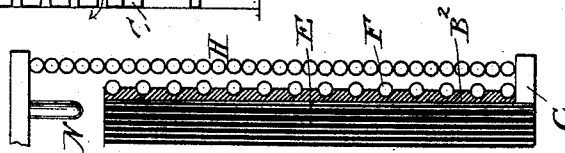
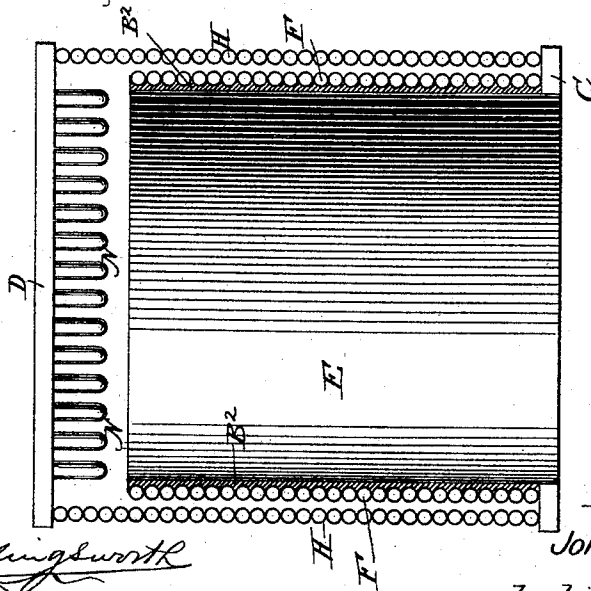

Fig. 5.
ON LINE 5-5



Witnesses

Stanley P. Hollingsworth
Battus DeLong

Inventor

JOHN BAIRD
by his attorneys

Baldwin Davidson & Wright

UNITED STATES PATENT OFFICE.

JOHN BAIRD, OF NEW YORK, N. Y.

STEAM-BOILER.

SPECIFICATION forming part of Letters Patent No. 458,817, dated September 1, 1891.

Application filed April 25, 1891. Serial No. 390,439. (No model.)

To all whom it may concern:

Be it known that I, JOHN BAIRD, mechanical engineer, a citizen of the United States, residing at No. 324 Lexington avenue, in the city, county, and State of New York, have invented certain new and useful Improvements in Steam-Boilers, of which the following is a specification.

My invention more especially relates to marine and stationary steam-boilers of the class having their flues horizontal or but slightly inclined and inclosed in suitable shells surrounded or inclosed by water-tubes, both horizontal and upright or slightly inclined, as exemplified, for instance, in United States Letters Patent No. 415,135, granted to me November 12, 1889.

The objects of my invention are to secure a compact, simple, safe, and efficient boiler of high steam-generating capacity, which ends I attain by certain novel organizations of instrumentalities hereinafter specified.

The accompanying drawings show my improvements as embodied in apparatus consisting, essentially, of a single large central or main shell and two side-shells or small shells somewhat on the plan shown in my patent above mentioned. So much only of the apparatus is, however, shown as is required to illustrate the subject-matter herein claimed. Unless otherwise indicated the parts are of usual approved construction.

The fire-door end of the boiler I term the "front" and the opposite end the "rear." That side on the right hand of a person facing the fire-doors I term the "right," the opposite side the "left." Short unfeathered darts indicate the direction of view of the corresponding sections, solid feathered arrows the course of the hot gases, and dotted ones that of the water.

Figure 1 is a vertical cross-section on the line 1 1 of Fig. 2, looking backward, the section being through the body of the boiler. Fig. 2 is an elevation of the right side of the boiler without its casing or jacketing; Fig. 3, a vertical longitudinal central section, looking to the left, on the line 3 3 of Fig. 1. Fig. 4 is a similar section showing two boilers placed end to end. Fig. 5 is a horizontal cross-section on the line 5 5 of Fig. 1, looking downward; and Fig. 6, a corresponding sec-

tional detail view showing a modification of the organization represented in Fig. 5. Fig. 7 is a vertical longitudinal section through one of the side shells on the line 7 7 of Fig. 1, looking to the left.

The products of combustion pass from the fire-box A through and around the various flues or fire-tubes and water-tubes by way of the back connection A', front hood or uptake A², direct flues A³, and return-flues A⁴ in the upper part of the boiler-shell, and thence up the chimney. A deflector *a*, projecting into the front hood, conducts a portion of the hot gases through the direct flues A³, back hood *a'*, and return-flues A⁴ to the chimney. The front head C and back head D are made of parallel plates with a water-space between them, and provided with the usual fire-doors and man-holes.

A large cylindrical shell E, with flat ends or heads, rests on the correspondingly-shaped front head and extends directly over the fire-box to the front end of the back connection, which is formed by a space left between the shell and head.

B represents the brick-work of the back connection.

About the lower two-thirds of the shell is filled with fire-tubes *e*. The lower part of the shell communicates with the water-space of the back head by a series of pipes *e'*, five or six in number, arranged horizontally across the back connection. The rear end of the shell is mainly supported by semi-girders E', fastened to it and resting on the back head. The normal water-line of the boiler comes just below the level of the direct flues A³. A steam-pipe G traverses the top of the shell longitudinally between the return-flues A⁴, and is thus dried and superheated.

The fire-tube portion of the boiler-shell is inclosed by a series of parallel water-tubes F, curved correspondingly with the contour of the boiler-shell, arranged close together, and constituting what I term a "series of belly-band tubes," which communicate with the bottom of the boiler-shell by openings or short vertical pipes *f*, as shown in United States Letters Patent respectively granted to me as No. 402,127, dated April 30, 1889, and No. 434,973, dated August 26, 1890, while their upper ends are connected with the steam-space of

the boiler by small curved pipes f' . The side walls of the furnace are also composed of a series of parallel upright or slightly-inclined water-tubes H, lying close together and filling the space between the front and back heads. The space between the belly-band tubes F and the boiler-shell is filled with fire-clay or fire-brick B^2 , thus protecting the boiler-shell from the direct action of the flame. In Fig. 6 every alternate tube F is shown as omitted and thicker fire-clay or brick-work interposed between them and the shell. These tubes, it will be observed, do not project back of the shell into the back connection.

The outer or casing tubes H are connected at bottom with their respective longitudinal water-supply pipes I, which are connected with the water-space of the back head and extend through the front head, with which, however, they are not connected to the feed-water-heating apparatus hereinafter described. The upper ends of the tubes H are connected with the boiler by small curved pipes h , which, together with the belly-band connecting pipes f' , above mentioned, pass through bracing-plates H' , secured to the boiler-shell. The casing-pipes H may be connected with the water-supply pipes I and with their own small pipes h at top and bottom, either or both, by expansion-joints or jam-nuts, such as shown in my patent, No. 415,135, above mentioned, and the belly-band pipes are provided with similar jam-nuts f^2 . In that patent, however, the casing-pipes are suspended from the jam-nuts and their supports; but in the present case, it will be observed, these pipes rest upon the water-supply pipes I at the bottom and are supported at their upper ends both by the brick-work B^2 and bracing-plates H' , above mentioned, which organization allows the pipes to expand and contract without injury. Instead of employing a separate small connecting-pipe h for each casing-tube, they might be arranged in gangs connected with a larger pipe h^2 , leading to the boiler, as shown in Fig. 2, where those of the back connection are shown as so connected. These casing-tubes are to be covered with asbestos or similar non-conducting material and outside plates of iron, and the whole boiler is to be suitably jacketed with non-conducting material.

Small side shells K extend lengthwise of the fire-box beneath and on each side of the main shell, with which they correspond in length, and are fitted with flues k to make a broader and more equable draft from the furnace and back connection to the front hood. The front ends of these shells extend through the front head, with which they are connected by small pipes k' . They are connected with the back head by a vertical pipe K' , which supports the rear end of each shell, and is connected by a horizontal pipe k^3 to the back head, thus serving both as a support and as a conduit or water-way. This pipe k^3 is preferably arranged outside the brick-work of the back connection, being cooler for joints, &c. These

shells are likewise supported by parallel longitudinal water-tubes J, connected with the front head and extending through packed sleeves in the back head, with which they are connected by smaller pipes j , substantially as shown in United States Letters Patent, respectively granted to me as No. 411,882, dated October 1, 1889, and No. 437,745, dated October 7, 1890. Similar water-tubes L M are shown as arranged between the side tubes and main shell, below the latter and on a level with the lower supporting-tubes of the lower shell.

The upper ends of the casing-tubes H, inclosing the back connection, are shown as connected by cross-pipes h^3 instead of being connected directly with the boiler, thus securing a circulation through them. I also utilize these pipes to support brick-work B' , interposed between them and the semi-girders E' and bridging the back connection, thus retaining the heat therein. Instead of using these pipes, I sometimes support this brick-work upon a series of pipes N, screwed into the back head.

Another division of this application, Serial No. 390,888, filed April 29, 1891, describes and claims these pipes and their water circulation.

Fig. 4 shows two such boilers as that above described arranged back to back and provided with a single back head, with which both sets of shells are connected, as hereinbefore described, and both sides of which head are exposed to the heat from the back connection. The advantage of such organization is obvious.

Water-boxes O, arranged on each side of the front of the fire-box, are connected by horizontal water-circulating tubes O' . Feed-water flows through a pipe o , provided with a check-valve o' , through the water-boxes and tubes O' , which traverse the uptake and are heated by the escaping gases. Pipes o^2 connect the water-circulating pipes with the water-supply pipes I. This feed-water-heating apparatus is not claimed herein *per se*, as it constitutes part of the subject-matter of an application for United States Letters Patent, Serial No. 386,335, filed by me March 25, 1891.

The boiler is of course, as before remarked, to be jacketed, wherever desirable, to prevent loss of heat by radiation, and is also to be provided with the most approved appurtenances—such as safety-valves, water-valves, cocks, &c.—for filling, emptying, or regulating the flow of air, steam, or water through the boiler.

The main shell, it will be observed, is of the form of a flat-ended cylinder of large diameter compared with its length, while the whole structure, including the casing-pipe, is substantially rectangular in cross-section. The larger portion of the main-boiler shell lies within the fire-box; but is protected from the direct action of the flame not only by its encompassing or belly-band pipes, but by the fire-clay or brick-work interposed between these pipes and the shell. Consequently

such a boiler cannot be regarded as an externally-fired one.

I claim herein as new and as of my own invention—

- 5 1. The combination, substantially as here-
inbefore set forth, of a boiler-shell and a series
of water-tubes encircling its lower portion,
the upper ends of the tubes being connected
10 with the steam-space of the boiler-shell
and their central portions with its water-space.
2. The combination, substantially as here-
inbefore set forth, of a boiler-shell, a series of
encompassing water-tubes connected with it,
15 and fire-brick or fire-clay interposed between
the tubes and shell.
3. The combination, substantially as here-
inbefore set forth, of a front head, a back
head, a boiler-shell, pipes connecting the
20 back head and boiler-shell, and a series of
encompassing water-tubes connected with the
shell.
4. The combination, substantially as here-
inbefore set forth, of two boiler-shells placed
25 end to end, a back head common to both
shells, pipes connecting both shells with the
back head, and a series of water-tubes en-
compassing the shells and connected there-
with.
- 30 5. The combination, substantially as here-
inbefore set forth, of a boiler-shell, the fire-
tubes traversing its water-space, direct and
return flues traversing its steam-space, a series
35 of water-tubes encircling the lower part
of the shell and connected both with its steam
and water space, a fire-box under the boiler
and tubes, a back connection, and an uptake
connected with the direct and return flues.
6. The combination, substantially as here-
40 inbefore set forth, of a boiler-shell, a series of
encompassing water-tubes connected with it,
and a series of parallel substantially vertical
water-tubes also inclosing the boiler and
connected therewith,
- 45 7. The combination, substantially as here-
inbefore set forth, of a boiler-shell, a series of
water-tubes encircling its lower portion, wa-
ter-passages connecting them with the water-
50 space of the boiler, pipes connecting them
with the steam-space of the boiler, and brac-
ing-plates and jam-nuts also connecting these
pipes and the boiler-shell.
8. The combination, substantially as here-
inbefore set forth, of a boiler-shell, its back
55 head, back connection, semi-girders connect-
ing the shell and back head, and brick-work
intermediate of the back connection and
these girders to confine the heat therein.
9. The combination, substantially as here-
60 inbefore set forth, of a boiler-shell, its back
head, a back connection, semi-girders connect-
ing the shell and back head, a series of
water-tubes projecting from the back head
into the back connection, and fire-brick in-
65 terposed between the water-tubes and the
semi-girders.
10. The combination, substantially as here-

inbefore set forth, of a boiler-shell, a front
head, a back head, horizontal longitudinal
water-pipes connecting the bottoms of these
70 heads, a series of upright side tubes connected
at the bottom with these tubes and at the top
with the steam-space of the boiler, bracing-
plates through which they pass, and jam-nuts
securing the side pipes in position. 75

11. The combination, substantially as here-
inbefore set forth, of a boiler-shell, its encom-
passing-tubes connected both with its steam
and water space, fire-brick intermediate be-
80 tween the shells and these tubes, and a series
of upright tubes constituting the side walls
of the furnace.

12. The combination, substantially as here-
inbefore set forth, of a front head, a back
head, a boiler-shell, tubes encompassing the
85 under side thereof and connected both with
the water and steam space of the shell, hori-
zontal longitudinal shells connecting the
heads, and upright side tubes connected with
these tubes at bottom and with the steam- 90
space of the boiler at the top.

13. The combination, substantially as here-
inbefore set forth, of a boiler-shell, its back
head, a back connection, upright water-tubes
inclosing the back connection, and transverse
95 pipes crossing the upper part of the back con-
nection and connecting these inclosing water-
tubes.

14. The combination, substantially as here-
inbefore set forth, of a boiler-shell, its back
100 head, a back connection, semi-girders connect-
ing the shell and back head, water-tubes
projecting from this head into this connec-
tion, upright side tubes inclosing the back
connection, cross-pipes connecting their up- 105
per ends, and fire-brick interposed between
the semi-girders and sustaining-pipes.

15. The combination, substantially as here-
inbefore set forth, of a front head, a back
110 head, a boiler-shell connected therewith, wa-
ter-tubes encompassing the lower part of the
boiler-shell and connected both with the
steam and water space thereof, longitudinal
water-pipes connecting the bottoms of the
115 front and back heads, upright side pipes connect-
ing these tubes with the boiler, water-
boxes connected with these longitudinal bot-
tom pipes, and feed-water-circulating pipes
connecting these boxes across the uptake to
120 heat the feed-water.

16. The combination, substantially as here-
inbefore set forth, of a front head, a back
head, and a boiler-shell K, connected directly
with one head at one end and supported at
the other by a pipe K' $\frac{1}{2}$, constituting its 125
connection with the other head.

17. The combination, substantially as here-
inbefore set forth, of a boiler-shell, a front
head, a back head, a back connection, an up-
right pipe supporting the back of the shell, and
130 a connecting-pipe crossing the back connec-
tion.

18. The combination, substantially as here-
inbefore set forth, of a boiler-shell, a front

head, a back head, a back connection, an upright pipe connected with the back head and sustaining the back of the shell, and longitudinal water-pipes encompassing the boiler-shell, connected with the front head, and passing through the back head across the back connection.

19. The combination, substantially as here-
inbefore set forth, of a fire-box, a front head,
a back head, a main shell connected with
them, water-tubes encompassing the main
shell and connected therewith, longitudinal
tubes connecting the bottoms of the front and
back heads, upright side tubes connected with
these longitudinal tubes at bottom and with
the main shell at the top, small shells inter-
posed between the encompassing tubes and
side tubes, longitudinal water-pipes support-
ing them, and vertical supporting-pipes con-
stituting the connection between the small
shells and back head.

20. The combination, substantially as here-
inbefore set forth, of a front head, a back
head, a main shell, its connected encompass-
ing pipes, longitudinal water-tubes connecting
the front and back heads, upright side tubes
connecting these longitudinal tubes with the
boiler-shell, side shells interposed between
the boiler-encompassing tubes and upright
side tubes, vertical water-pipes sustaining the

rear ends of these shells, and longitudinal wa-
ter-tubes connecting the front and back heads.

21. The combination, substantially as here-
inbefore set forth, of a fire-box, front head,
back head, a main shell connected therewith,
its encompassing water-tubes, longitudinal
water-tubes connecting the heads near their
bottoms, upright side tubes connecting these
longitudinal tubes with the main boiler-shell,
small shells interposed between the main shell
and side tubes, and longitudinal water-tubes
connecting the front and back heads.

22. The combination, substantially as here-
inbefore set forth, of two boiler-shells placed
end to end, a back head common to both, semi-
girders extending across the back head and
supporting both shells, and a steam-pipe also
common to both shells.

23. The combination, substantially as here-
inbefore set forth, of two boiler-shells placed
end to end, a back head common to both
shells, semi-girders connecting them, and fire-
brick constituting the roof of the back con-
nection of each shell.

In testimony whereof I have hereunto sub-
scribed my name.

JOHN BAIRD.

Witnesses:

A. J. BAIRD,

ADDISON W. BAIRD.