



US00RE50041E

(19) **United States**
(12) **Reissued Patent**
Hirasawa et al.

(10) **Patent Number:** **US RE50,041 E**
(45) **Date of Reissued Patent:** ***Jul. 16, 2024**

(54) **LIGHT-EMITTING APPARATUS**

(71) Applicant: **PANASONIC INTELLECTUAL PROPERTY MANAGEMENT CO., LTD.**, Osaka (JP)

(72) Inventors: **Taku Hirasawa**, Kyoto (JP); **Yasuhisa Inada**, Osaka (JP); **Akira Hashiya**, Osaka (JP); **Nobuaki Nagao**, Gifu (JP); **Akira Tsujimoto**, Nara (JP)

(73) Assignee: **PANASONIC INTELLECTUAL PROPERTY MANAGEMENT CO., LTD.**, Osaka (JP)

(*) Notice: This patent is subject to a terminal disclaimer.

(21) Appl. No.: **17/364,359**

(22) Filed: **Jun. 30, 2021**

Related U.S. Patent Documents

Reissue of:

(64) Patent No.: **10,359,155**
Issued: **Jul. 23, 2019**
Appl. No.: **15/206,273**
Filed: **Jul. 10, 2016**

(30) **Foreign Application Priority Data**

Aug. 20, 2015 (JP) 2015-162403
Aug. 20, 2015 (JP) 2015-162404
(Continued)

(51) **Int. Cl.**
F21V 9/30 (2018.01)
F21K 9/64 (2016.01)
(Continued)

(52) **U.S. Cl.**
CPC **F21K 9/64** (2016.08); **F21V 5/04** (2013.01); **F21V 5/10** (2018.02); **F21V 7/30** (2018.02);
(Continued)

(58) **Field of Classification Search**

CPC F21V 9/30; F21V 9/32; F21V 9/35; F21V 9/38; F21V 9/40; F21V 13/08; F21V 13/14; F21V 5/10; F21K 9/64
See application file for complete search history.

(56) **References Cited**

U.S. PATENT DOCUMENTS

5,517,039 A 5/1996 Holonyak, Jr. et al.
5,732,102 A 3/1998 Bouadma
(Continued)

FOREIGN PATENT DOCUMENTS

JP 9-073807 3/1997
JP 11-283751 10/1999
(Continued)

OTHER PUBLICATIONS

Ex Parte Quayle Office Action issued in U.S. Appl. No. 15/166,123, mailed on Mar. 28, 2018.
(Continued)

Primary Examiner — James A Menefee
(74) *Attorney, Agent, or Firm* — Rimon P.C.

(57) **ABSTRACT**

A light-emitting apparatus includes an excitation light source that emits first light; a light-emitting device on an optical path of the first light, the light-emitting device emitting second light having a wavelength in air; and a first converging lens on an optical path of the second light. The light-emitting device comprises: a photoluminescent layer that emits the second light by being excited by the first light; and a light-transmissive layer on the photoluminescent layer. At least one of the photoluminescent layer and the light-transmissive layer has a surface structure comprising projections or recesses arranged perpendicular to a thickness direction of the photoluminescent layer. At least one of the photoluminescent layer and the light-transmissive layer has a light emitting surface perpendicular to the thickness direction, the second light emitted from the light emitting surface.

(Continued)

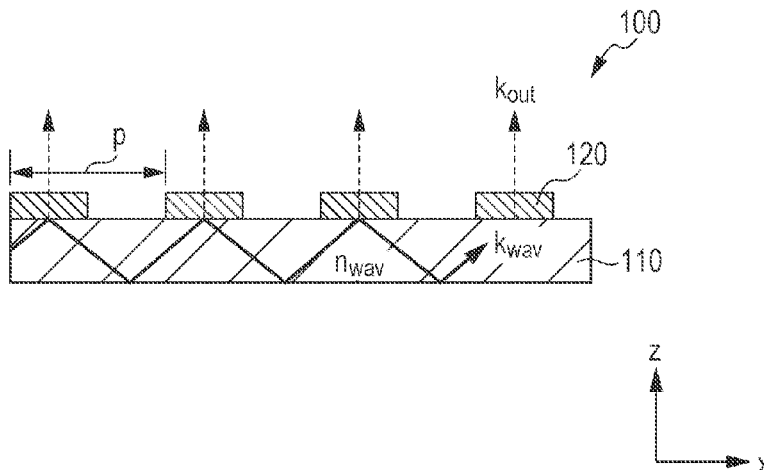

The surface structure limits the directional angle of the second light emitted from the light emitting surface.

15 Claims, 75 Drawing Sheets

(30) Foreign Application Priority Data

Aug. 20, 2015 (JP) 2015-162405
 Aug. 20, 2015 (JP) 2015-163042
 Aug. 21, 2015 (JP) 2015-163680
 Aug. 21, 2015 (JP) 2015-163681
 Mar. 31, 2016 (JP) 2016-070837

(51) Int. Cl.

F21V 5/04 (2006.01)
F21V 5/10 (2018.01)
F21V 7/30 (2018.01)
F21V 9/40 (2018.01)
F21V 13/14 (2006.01)
H01S 5/00 (2006.01)
F21Y 115/10 (2016.01)
F21Y 115/30 (2016.01)

(52) U.S. Cl.

CPC **F21V 9/40** (2018.02); **F21V 13/14**
 (2013.01); **H01S 5/00** (2013.01); **F21Y**
2115/10 (2016.08); **F21Y 2115/30** (2016.08)

(56)

References Cited

U.S. PATENT DOCUMENTS

6,402,347 B1 * 6/2002 Maas G02B 19/0066
 362/547
 6,483,096 B1 11/2002 Kunz et al.
 6,728,034 B1 4/2004 Nakanishi et al.
 7,619,357 B2 11/2009 Onishi et al.
 7,699,482 B2 4/2010 Noguchi
 8,227,966 B2 7/2012 Wakabayashi et al.
 8,324,647 B2 * 12/2012 McKenzie H01L 33/507
 257/E33.072
 8,619,363 B1 12/2013 Coleman
 9,158,215 B2 10/2015 Yu
 9,515,239 B2 12/2016 Inada et al.
 9,518,215 B2 12/2016 Hirasawa et al.
 9,618,697 B2 4/2017 Inada et al.
 9,880,336 B2 1/2018 Inada et al.
 9,890,912 B2 2/2018 Hashiya et al.
 10,012,780 B2 7/2018 Inada et al.
 10,031,276 B2 * 7/2018 Hirasawa G02B 6/005
 10,113,712 B2 * 10/2018 Inada F21V 13/14
 RE49,093 E * 6/2022 Nagao H01L 33/502
 2002/0180348 A1 12/2002 Oda et al.
 2003/0021314 A1 1/2003 Yoshida et al.
 2003/0169792 A1 9/2003 Kim
 2004/0141108 A1 7/2004 Tanaka et al.
 2004/0233534 A1 11/2004 Nakanishi et al.
 2006/0039433 A1 2/2006 Simpson
 2006/0088066 A1 4/2006 He
 2007/0031097 A1 2/2007 Heikenfeld et al.
 2007/0103931 A1 5/2007 Lee et al.
 2007/0138479 A1 6/2007 Yamazaki et al.
 2007/0153860 A1 7/2007 Chang-Hasnain et al.
 2008/0069497 A1 3/2008 Tissot et al.
 2008/0089089 A1 4/2008 Hama et al.
 2008/0149916 A1 6/2008 Baba et al.
 2008/0258160 A1 10/2008 Do
 2008/0303419 A1 12/2008 Fukuda
 2009/0021153 A1 1/2009 Lee et al.
 2009/0040598 A1 2/2009 Ito
 2009/0040745 A1 2/2009 Nemchuk
 2009/0066241 A1 3/2009 Yokoyama

2009/0129115 A1 5/2009 Fine et al.
 2009/0190068 A1 7/2009 Kawamura
 2009/0206325 A1 8/2009 Biwa
 2009/0267092 A1 10/2009 Fukushima et al.
 2009/0286337 A1 11/2009 Lee et al.
 2010/0074284 A1 3/2010 Aizawa et al.
 2010/0142189 A1 6/2010 Hong et al.
 2010/0164365 A1 7/2010 Yoshino et al.
 2010/0176751 A1 7/2010 Oshio et al.
 2010/0246210 A1 9/2010 Yashiro
 2010/0277887 A1 * 11/2010 Su H01L 33/44
 362/19
 2011/0101359 A1 5/2011 Kim et al.
 2011/0198563 A1 8/2011 Kim et al.
 2011/0198645 A1 8/2011 Jo et al.
 2012/0018705 A1 1/2012 Takazoe et al.
 2012/0106127 A1 5/2012 Hattori et al.
 2012/0119638 A1 5/2012 Sato et al.
 2012/0170282 A1 * 7/2012 Lin G02F 1/133606
 362/341
 2012/0176766 A1 7/2012 Natsumeda
 2012/0224378 A1 9/2012 Koike et al.
 2012/0286258 A1 11/2012 Naraoka et al.
 2012/0292652 A1 11/2012 Yamae et al.
 2013/0069046 A1 3/2013 Ishizuya
 2013/0181195 A1 7/2013 Cho et al.
 2013/0208327 A1 8/2013 Bolle et al.
 2013/0208442 A1 * 8/2013 Reiherzer B29C 43/146
 216/13
 2013/0277703 A1 10/2013 Matsuzaki
 2013/0308102 A1 11/2013 Natsumeda et al.
 2014/0022818 A1 1/2014 Natsumeda et al.
 2014/0071683 A1 * 3/2014 Hamada C09K 11/08
 362/259
 2014/0092620 A1 4/2014 Tissot
 2014/0185316 A1 7/2014 Kim et al.
 2014/0306176 A1 10/2014 Chiu et al.
 2014/0362604 A1 12/2014 Masuda
 2015/0085469 A1 3/2015 Kamee
 2015/0249183 A1 9/2015 Hirasawa et al.
 2015/0249186 A1 9/2015 Inada et al.
 2015/0249187 A1 9/2015 Inada et al.
 2015/0252964 A1 * 9/2015 Takahashi F21K 9/60
 362/84
 2015/0286120 A1 * 10/2015 Ohno G02B 26/10
 362/326
 2016/0040857 A1 * 2/2016 Inoue F21V 7/30
 362/343
 2016/0265746 A1 9/2016 Hirasawa et al.
 2016/0265747 A1 9/2016 Nagao et al.
 2016/0265749 A1 9/2016 Inada
 2016/0327703 A1 11/2016 Hirasawa et al.
 2016/0327706 A1 11/2016 Hirasawa et al.
 2016/0327715 A1 11/2016 Inada et al.
 2016/0327716 A1 11/2016 Inada et al.
 2016/0327717 A1 11/2016 Hashiya et al.
 2016/0327739 A1 11/2016 Nakamura et al.
 2017/0012232 A1 1/2017 Kataishi et al.
 2017/0075169 A1 3/2017 Hayama

FOREIGN PATENT DOCUMENTS

JP 2001-059905 3/2001
 JP 2001-155520 6/2001
 JP 2006-269294 A 10/2006
 JP 2007-103901 4/2007
 JP 2007-240641 9/2007
 JP 2008-130279 6/2008
 JP 2008-521211 6/2008
 JP 2008-521211 A 6/2008
 JP 2008-227458 9/2008
 JP 2009-140894 6/2009
 JP 2010-015874 1/2010
 JP 2010-033772 2/2010
 JP 2010-035922 A 2/2010
 JP 2010-097178 4/2010
 JP 2010-097179 4/2010
 JP 2010-199357 9/2010

(56)

References Cited

FOREIGN PATENT DOCUMENTS

JP	2010-210824	9/2010
JP	2010-210824 A	9/2010
JP	2010-231941	10/2010
JP	2010-237311	10/2010
JP	2011-166148	8/2011
JP	2011-166148 A	8/2011
JP	2012-093454	5/2012
JP	2012-109334	6/2012
JP	2012-109400	6/2012
JP	2012-182376	9/2012
JP	2013-183020	9/2013
JP	2014-075584	4/2014
JP	2014-082401	5/2014
JP	2014-082401 A	5/2014
JP	2014-092645	5/2014
JP	2014-092645	8/2014
JP	2014-523603	9/2014
WO	2007/034827	3/2007
WO	2007/034827 A1	3/2007
WO	2007/091687	8/2007
WO	2009/005311	1/2009
WO	2009/099211	8/2009
WO	2011/040528	4/2011
WO	2012/049905	4/2012
WO	2012/108384	8/2012
WO	2012/137583	10/2012
WO	2012/137583 A1	10/2012
WO	2012/137584	10/2012
WO	2013/084442	6/2013
WO	2013/125567	8/2013
WO	2013/172025	11/2013
WO	2013/172025 A1	11/2013
WO	2014/024218	2/2014
WO	2014/119783	8/2014
WO	2015/045886	4/2015

OTHER PUBLICATIONS

Non-Final Office Action issued in U.S. Appl. No. 15/060,583, mailed on Nov. 30, 2017.

Notice of Allowance issued in U.S. Appl. No. 14/618,591, mailed on Aug. 2, 2016.

Notice of Allowance issued in U.S. Appl. No. 14/621,729, mailed on Dec. 13, 2016.

Notice of Allowance issued in U.S. Appl. No. 15/060,583, mailed on Jul. 10, 2018.

Specification of U.S. Appl. No. 15/060,583, filed Mar. 3, 2016.

Specification of U.S. Appl. No. 15/206,273, filed Jul. 10, 2016.

Notice of Allowance issued in U.S. Appl. No. 15/214,837 mailed on Nov. 7, 2017.

Non-Final Office Action issued in U.S. Appl. No. 15/215,592 mailed on Dec. 7, 2017.

Notice of Allowance issued in U.S. Appl. No. 15/215,592 mailed on May 16, 2018.

Final Office Action issued in U.S. Appl. No. 15/215,599 mailed on Feb. 15, 2018.

Notice of Allowance issued in U.S. Appl. No. 15/216,669 mailed on Nov. 8, 2017.

Ex Parte Quayle Office Action issued in U.S. Appl. No. 15/216,686, mailed on Dec. 7, 2017.

Final Office Action issued in U.S. Appl. No. 15/219,462 mailed on Jun. 27, 2018.

Specification of U.S. Appl. No. 15/060,574, filed Mar. 3, 2016.

Specification of U.S. Appl. No. 14/618,591, filed Feb. 10, 2015.

Specification of U.S. Appl. No. 14/621,729, filed Feb. 13, 2015.

Specification of U.S. Appl. No. 14/618,254, filed Feb. 10, 2015.

Notice of Allowance issued in U.S. Appl. No. 14/618,254 mailed on Aug. 22, 2016.

Specification of U.S. Appl. No. 15/060,564, filed Mar. 3, 2016.

Non-Final Office Action issued in U.S. Appl. No. 15/169,771, mailed on Aug. 16, 2017.

Non-Final Office Action issued in U.S. Appl. No. 15/214,803, mailed on Aug. 8, 2017.

Non-Final Office Action issued in U.S. Appl. No. 15/214,837, mailed on Sep. 12, 2017.

Non-Final Office Action issued in U.S. Appl. No. 15/215,595, mailed on Jul. 28, 2017.

Notice of Allowance issued in U.S. Appl. No. 15/215,595, mailed on Sep. 22, 2017.

Non-Final Office Action issued in U.S. Appl. No. 15/215,599, mailed on Aug. 25, 2017.

Non-Final Office Action issued in U.S. Appl. No. 15/219,462, mailed on Sep. 26, 2017.

Notice of Allowance issued in U.S. Appl. No. 15/169,771 mailed on Oct. 24, 2017.

Non-Final Office Action issued in U.S. Appl. No. 15/216,669, mailed on Apr. 14, 2017.

Non-Final Office Action issued in U.S. Appl. No. 15/060,574 mailed on Jan. 16, 2018.

Final Office Action issued in U.S. Appl. No. 15/214,803, mailed on Feb. 5, 2018.

Non-Final Office Action issued in U.S. Appl. No. 14/618,591, mailed on Nov. 9, 2015.

Final Office Action issued in U.S. Appl. No. 14/618,591, mailed on May 19, 2016.

Non-Final Office Action issued in U.S. Appl. No. 14/618,254 mailed on Feb. 3, 2016.

Non-Final Office Action issued in U.S. Appl. No. 14/621,729, mailed on Mar. 9, 2016.

Final Office Action issued in U.S. Appl. No. 14/621,729 mailed on Sep. 28, 2016.

Notice of Allowance issued in U.S. Appl. No. 15/060,564 mailed on Mar. 21, 2018.

Notice of Allowance issued in U.S. Appl. No. 15/216,686 mailed on Mar. 26, 2018.

Final Office Action issued in U.S. Appl. No. 15/215,592, mailed on Apr. 9, 2018.

Non-Final Office Action issued in U.S. Appl. No. 15/219,462, mailed on Feb. 28, 2018.

Notice of Allowance issued in U.S. Appl. No. 15/214,523 mailed on Aug. 10, 2018.

Notice of Allowance issued in U.S. Appl. No. 15/060,574 mailed on Sep. 12, 2018.

Non-Final Office Action issued in U.S. Appl. No. 15/206,273, mailed on Sep. 21, 2018.

Final Office Action issued in U.S. Appl. No. 15/206,273, mailed on Jan. 30, 2019.

Notice of Allowance issued in U.S. Appl. No. 15/206,273 mailed on Mar. 21, 2019.

Notice of Allowance issued in U.S. Appl. No. 15/446,453 mailed on Jul. 7, 2018.

Ex Parte Quayle Office Action issued in U.S. Appl. No. 15/166,123, mailed on Jan. 30, 2019.

Notice of Allowance issued in U.S. Appl. No. 15/166,123 mailed on Jul. 17, 2018.

The Extended European Search Report dated Dec. 16, 2016 for the related European Patent Application No. 14883764.4.

Specification of U.S. Appl. No. 15/446,453, filed Mar. 1, 2017.

International Search Report of PCT application No. PCT/JP2015/000810 dated Apr. 7, 2015.

International Search Report of PCT application No. PCT/JP2015/000811 dated Apr. 7, 2015.

International Search Report of PCT application No. PCT/JP2015/000812 dated Apr. 7, 2015.

International Search Report of PCT application No. PCT/JP2015/000813 dated May 19, 2015.

International Search Report of PCT application No. PCT/JP2015/000814 dated May 26, 2015.

International Search Report of PCT application No. PCT/JP2015/000815 dated Apr. 7, 2015.

International Search Report of PCT application No. PCT/JP2014/004324 dated Nov. 25, 2014; with English translation.

Specification of U.S. Appl. No. 15/166,123, filed May 26, 2016.

Specification of U.S. Appl. No. 15/169,771, filed Jun. 1, 2016.

(56)

References Cited

OTHER PUBLICATIONS

Specification of U.S. Appl. No. 15/214,523, filed Jul. 20, 2016.
Specification of U.S. Appl. No. 15/214,803, filed Jul. 20, 2016.
Specification of U.S. Appl. No. 15/214,837, filed Jul. 20, 2016.
Specification of U.S. Appl. No. 15/215,592, filed Jul. 21, 2016.
Specification of U.S. Appl. No. 15/215,595, filed Jul. 21, 2016.
Specification of U.S. Appl. No. 15/215,599, filed Jul. 21, 2016.
Specification of U.S. Appl. No. 15/216,669, filed Jul. 21, 2016.
Specification of U.S. Appl. No. 15/216,686, filed Jul. 21, 2016.
Specification of U.S. Appl. No. 15/219,462, filed Jul. 26, 2016.
English translation of Search Report for Chinese application No.
201610261401.1, dated Dec. 29, 2018.
English translation of Search Report for Chinese application No.
201610256719.0, dated Dec. 29, 2018.

* cited by examiner

FIG. 1A

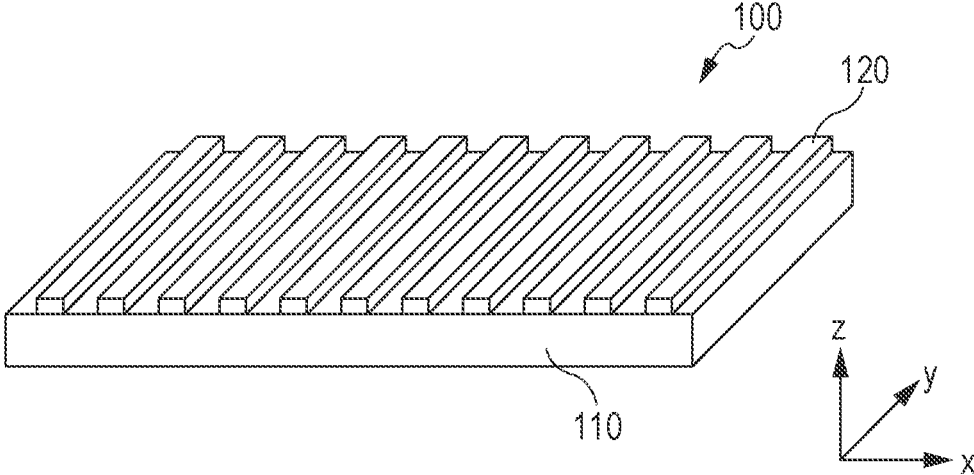

FIG. 1B

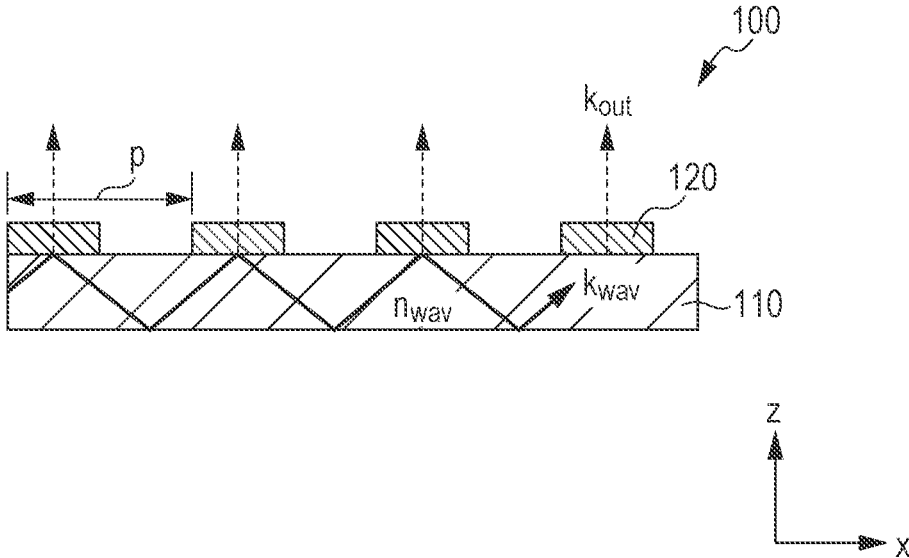

FIG. 1C

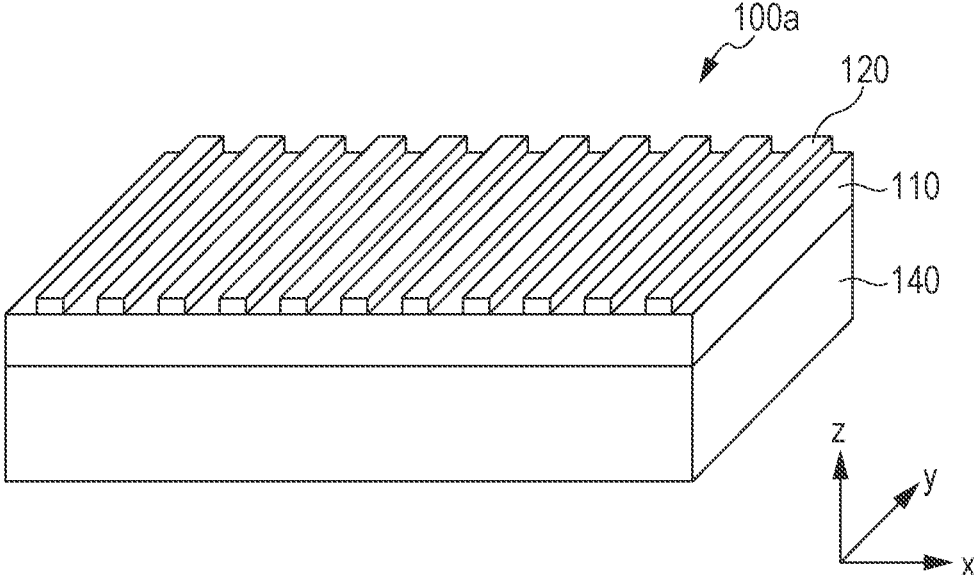

FIG. 1D

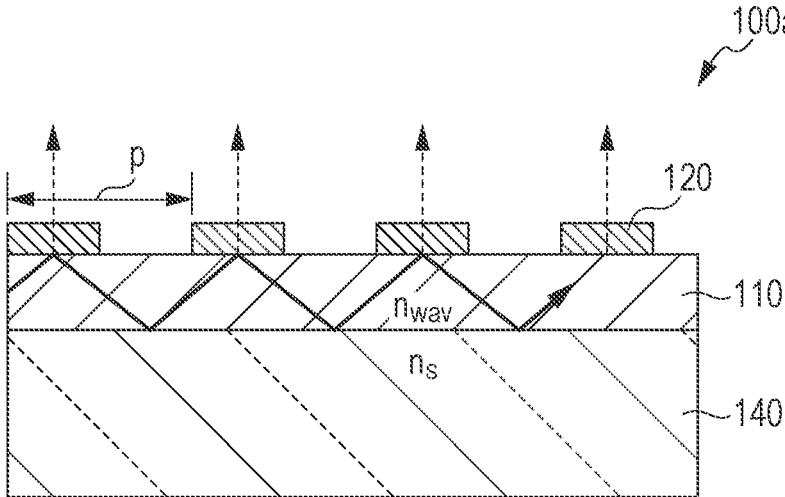

FIG. 2

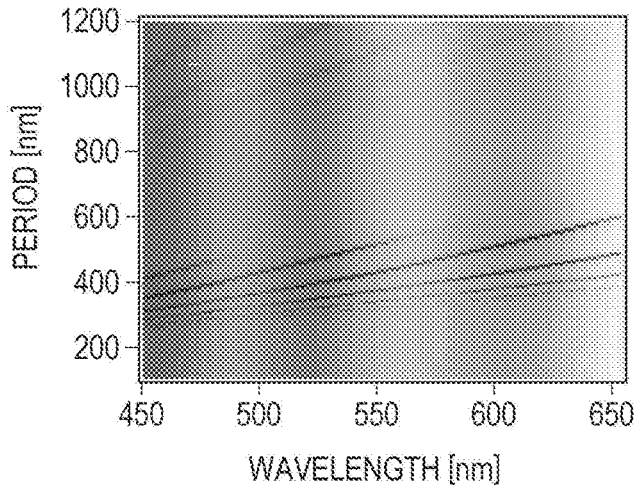

FIG. 3

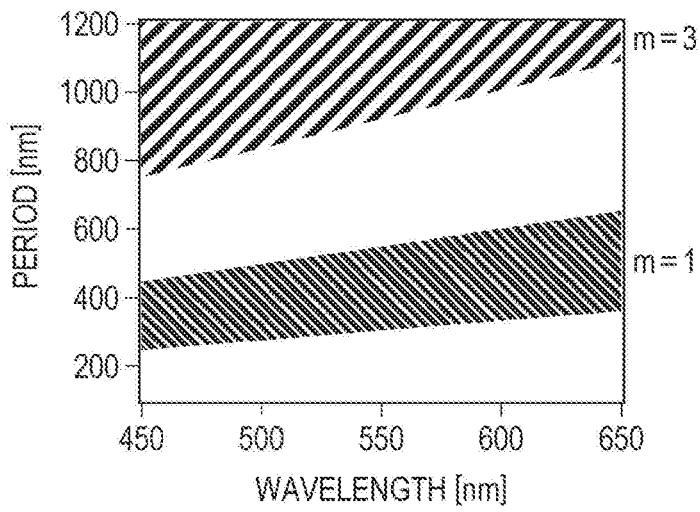

FIG. 4

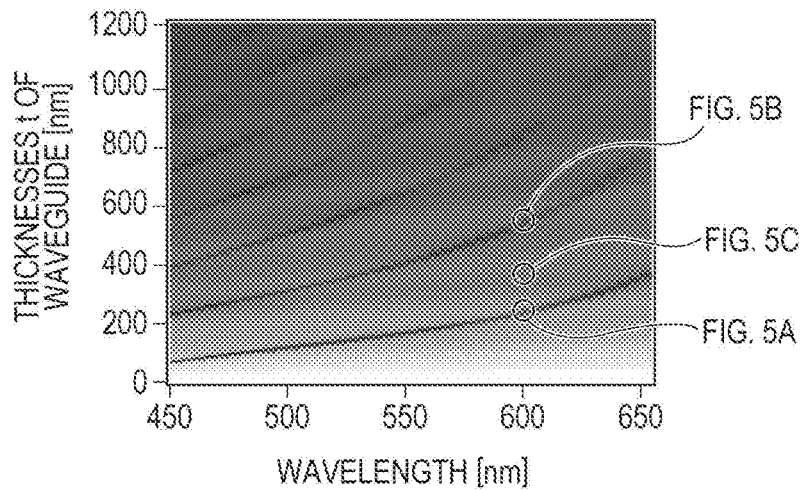

FIG. 5A

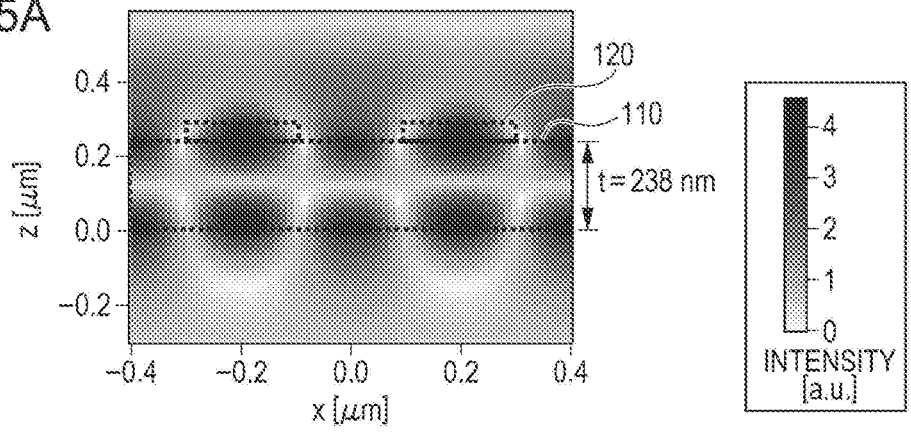

FIG. 5B

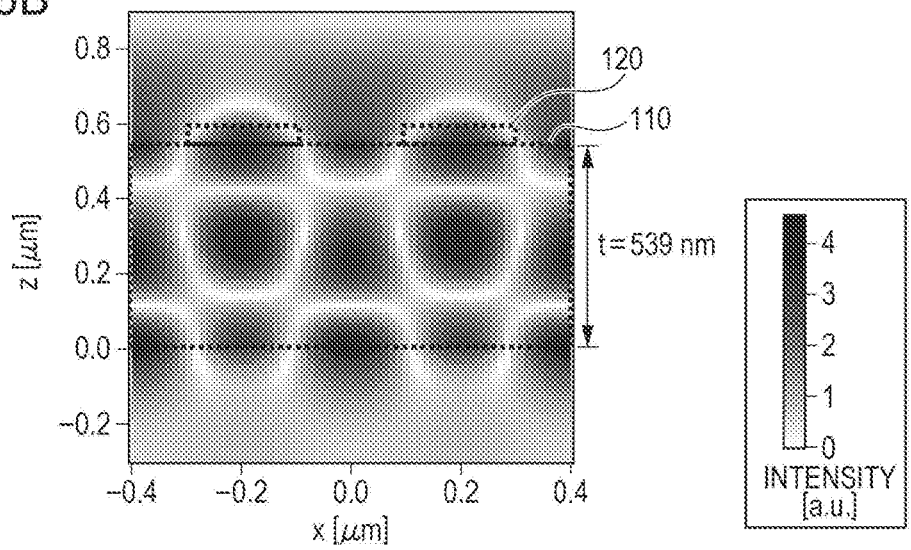

FIG. 5C

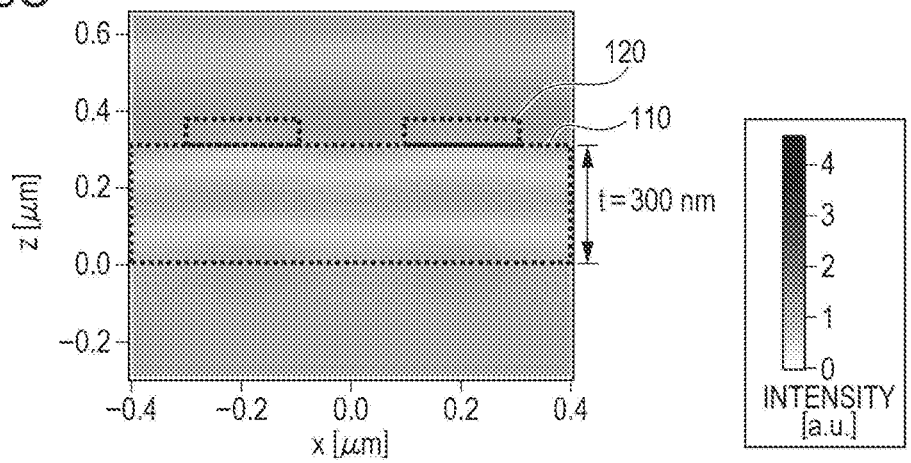

FIG. 6

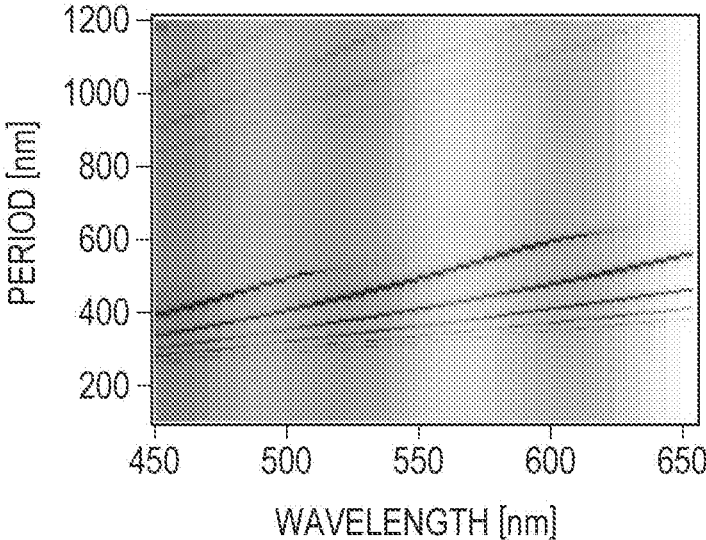

FIG. 7A

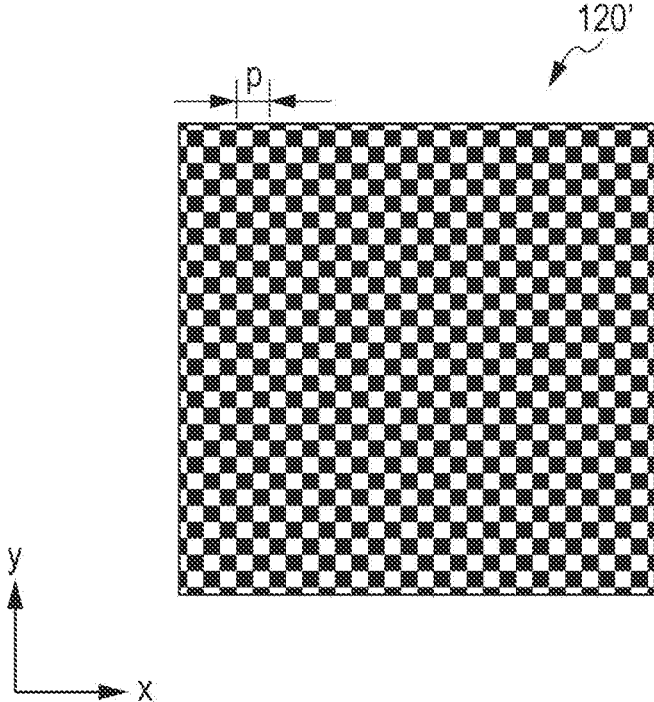

FIG. 7B

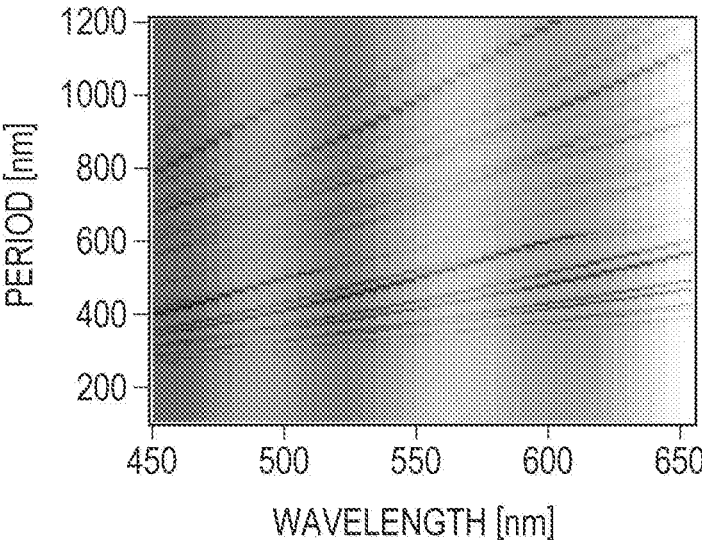

FIG. 8

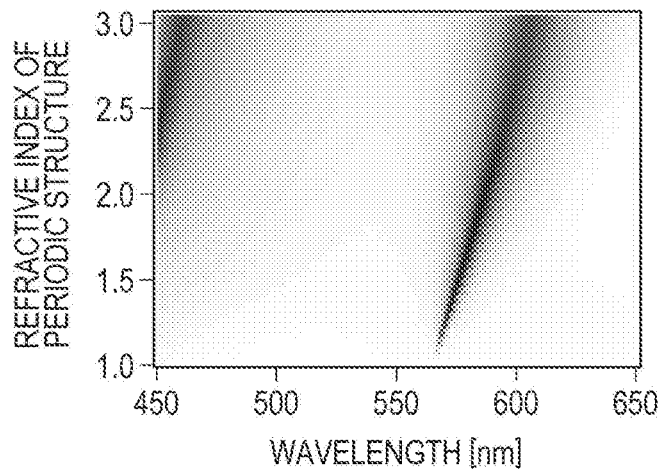

FIG. 9

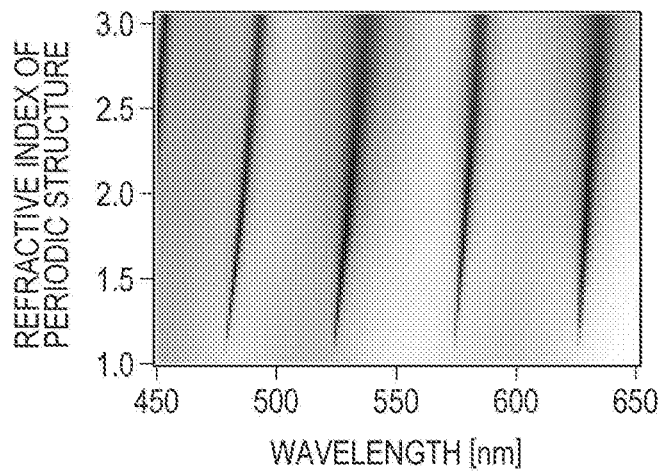

FIG. 10

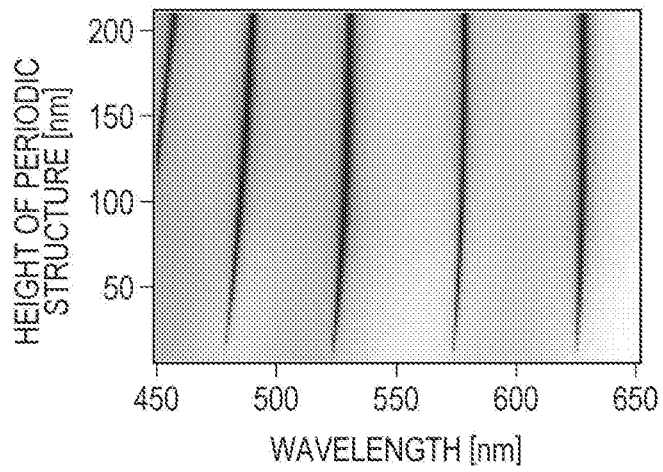

FIG. 11

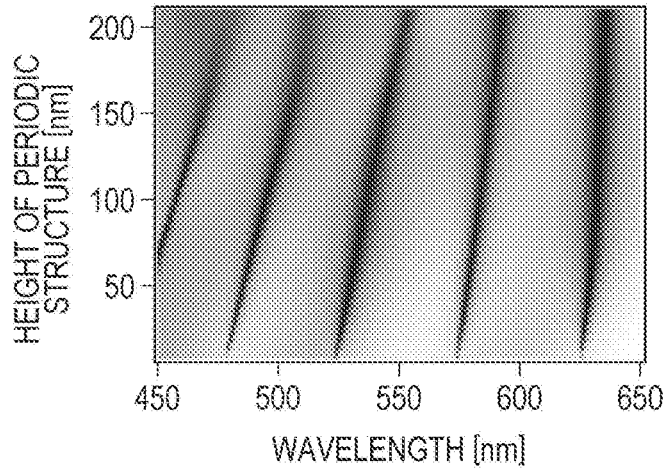

FIG. 12

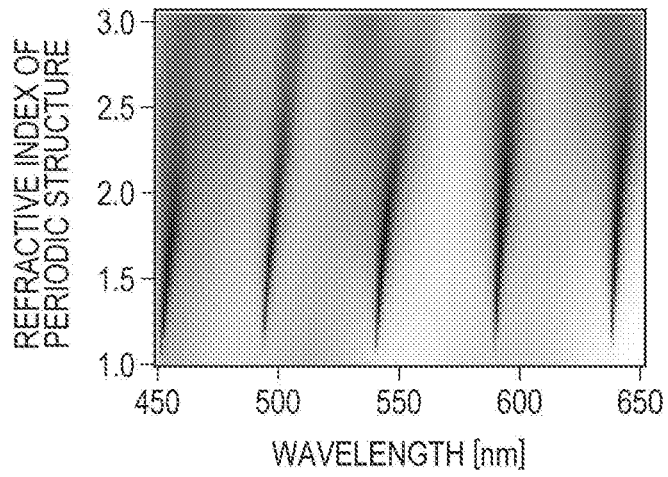

FIG. 13

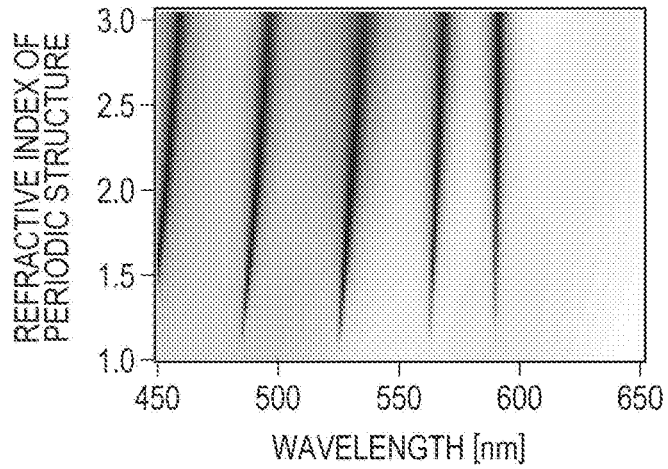

FIG. 14

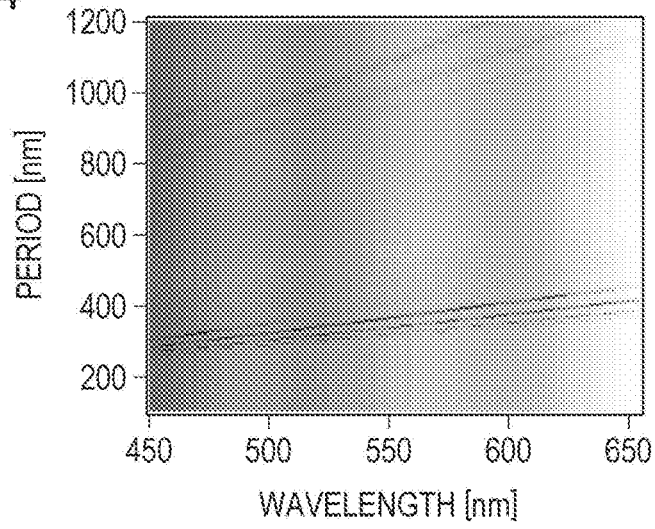

FIG. 15

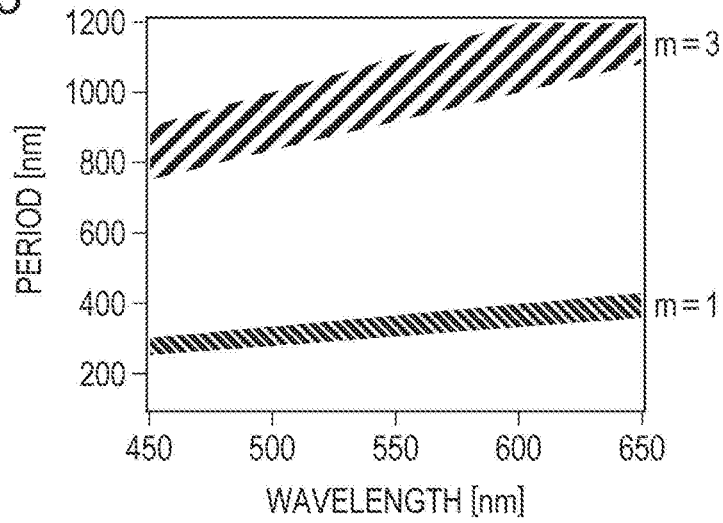

FIG. 16

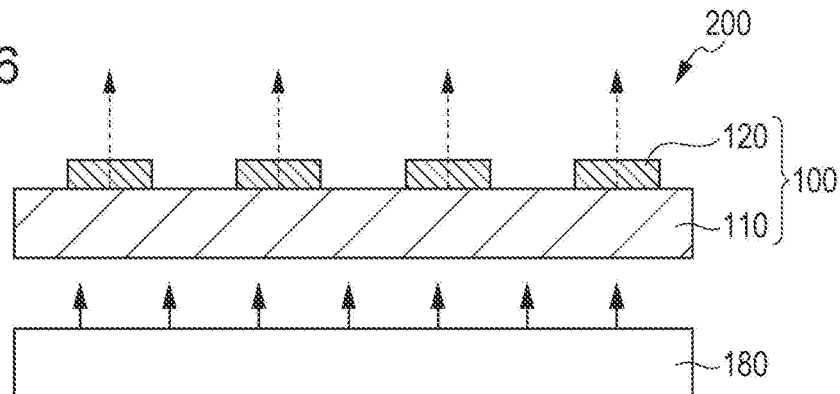

FIG. 17A

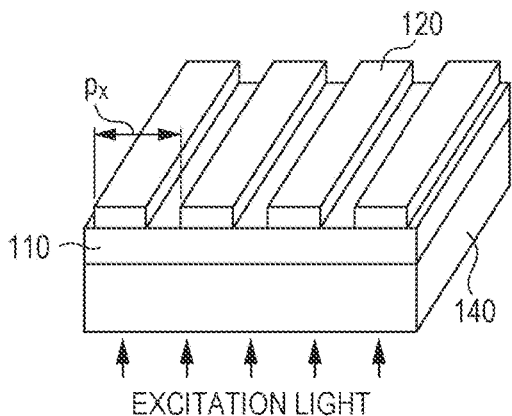

FIG. 17B

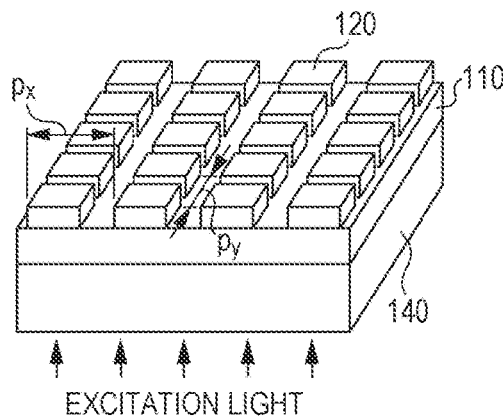

FIG. 17C

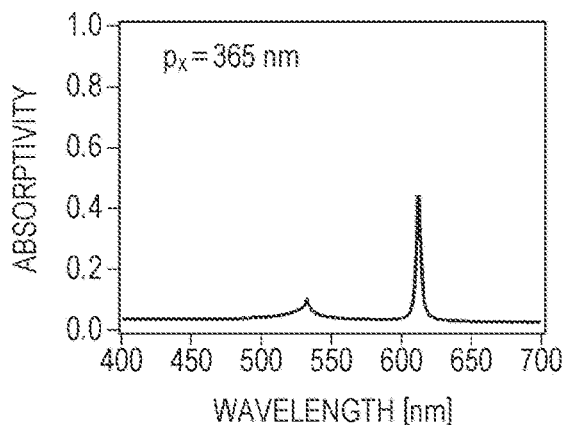

FIG. 17D

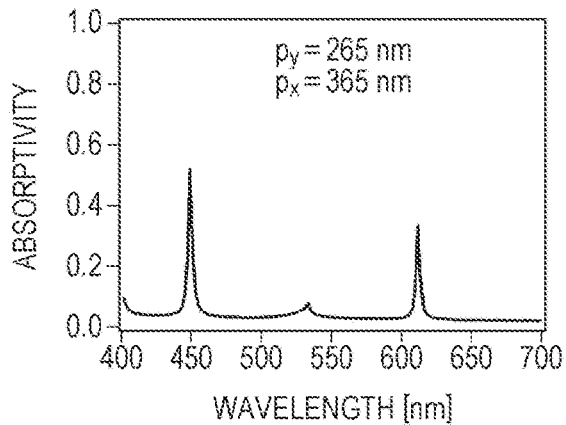

FIG. 18A

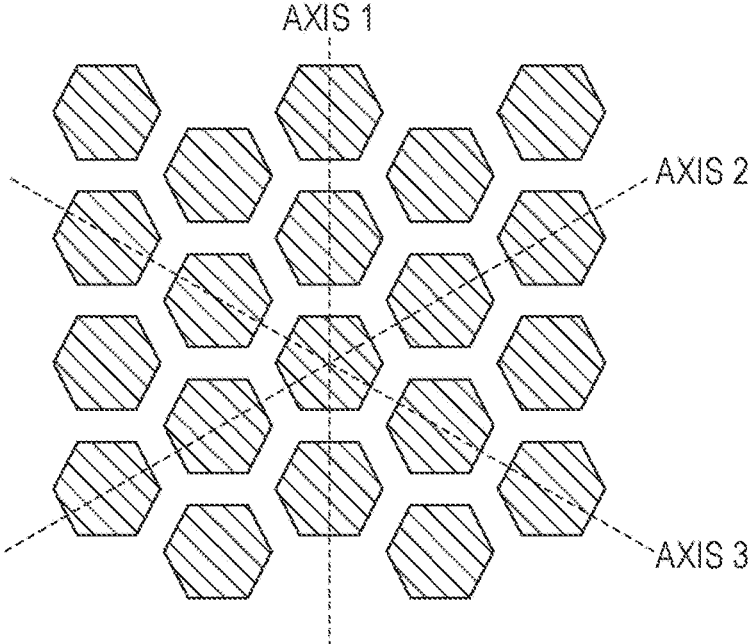

FIG. 18B

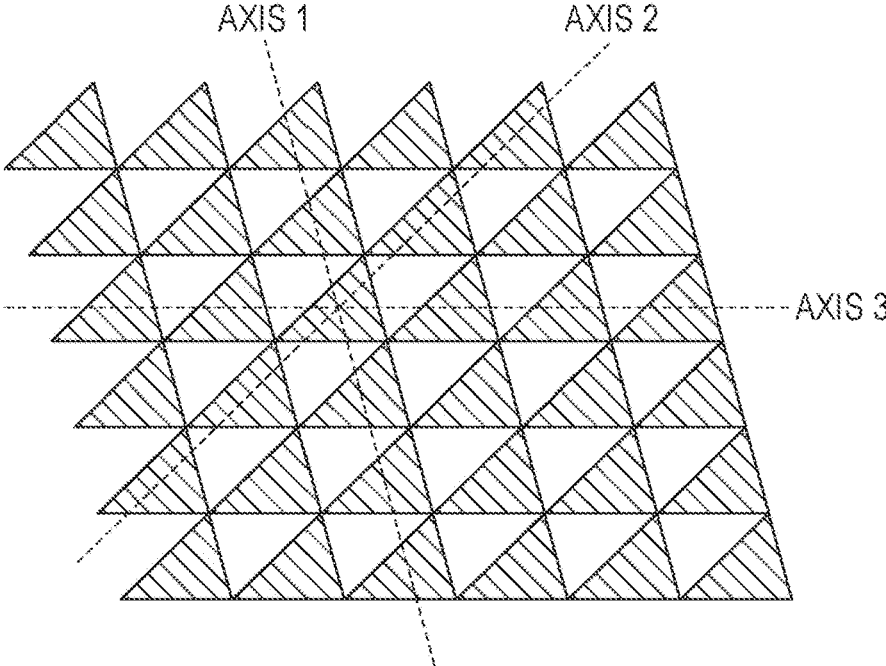

FIG. 19A

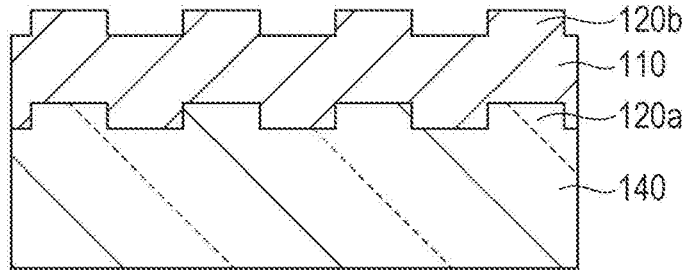

FIG. 19B

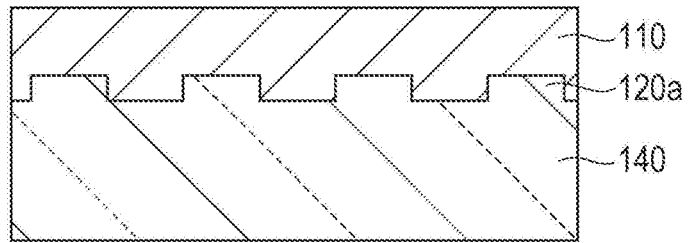

FIG. 19C

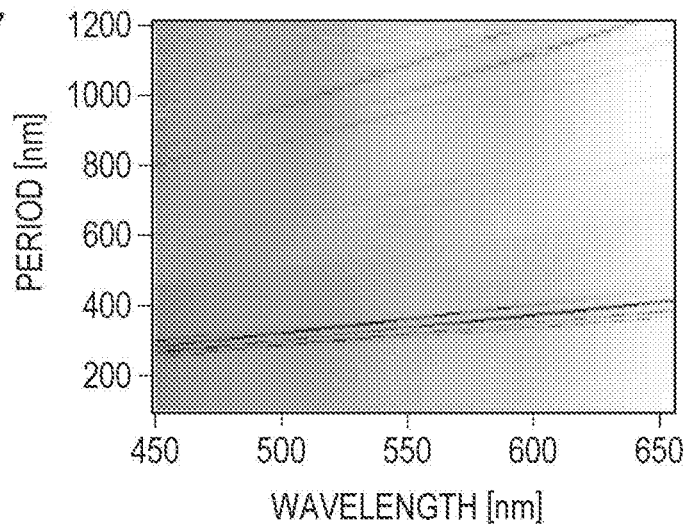

FIG. 20

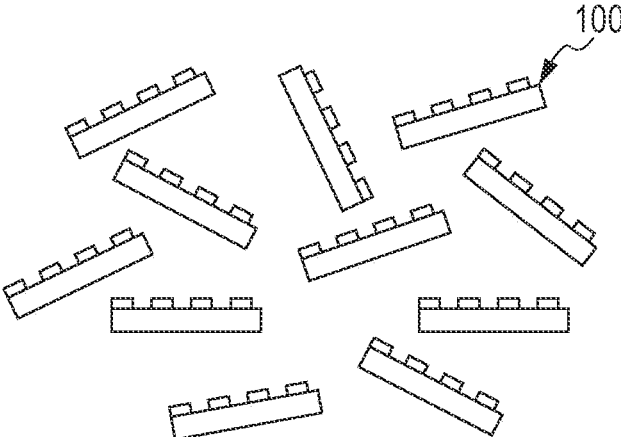

FIG. 21

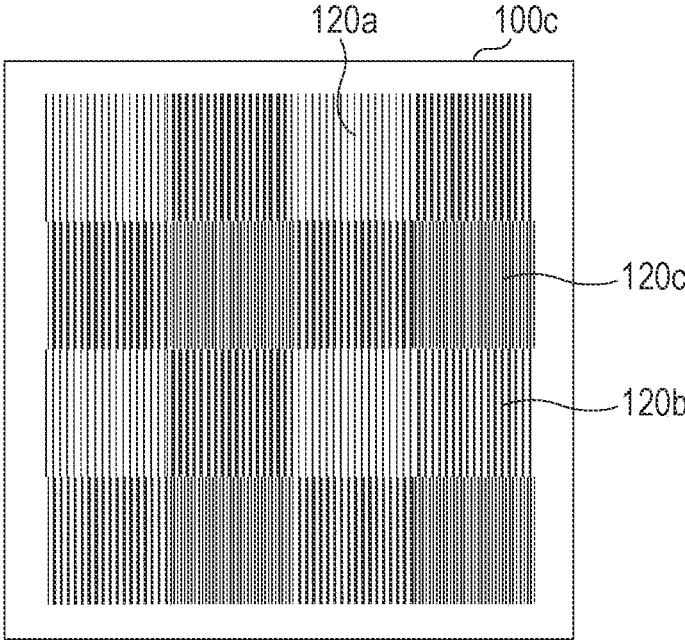

FIG. 22

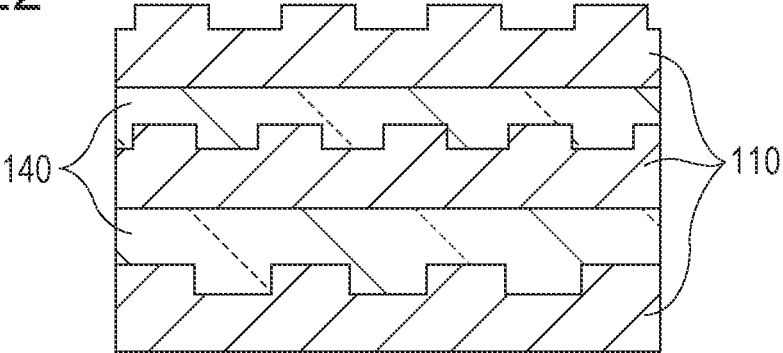

FIG. 23

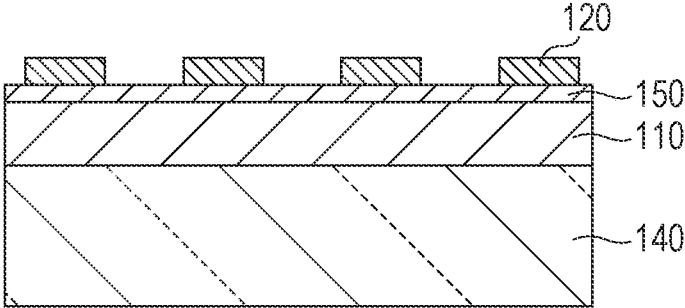

FIG. 24

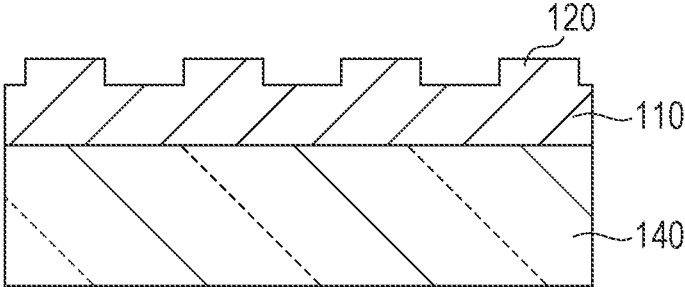

FIG. 25

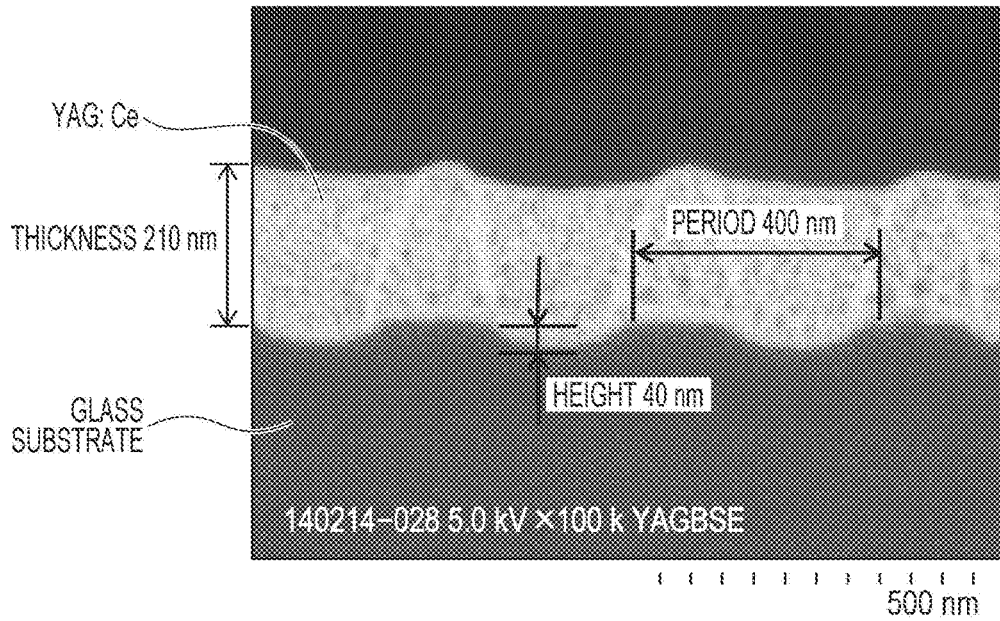

FIG. 26

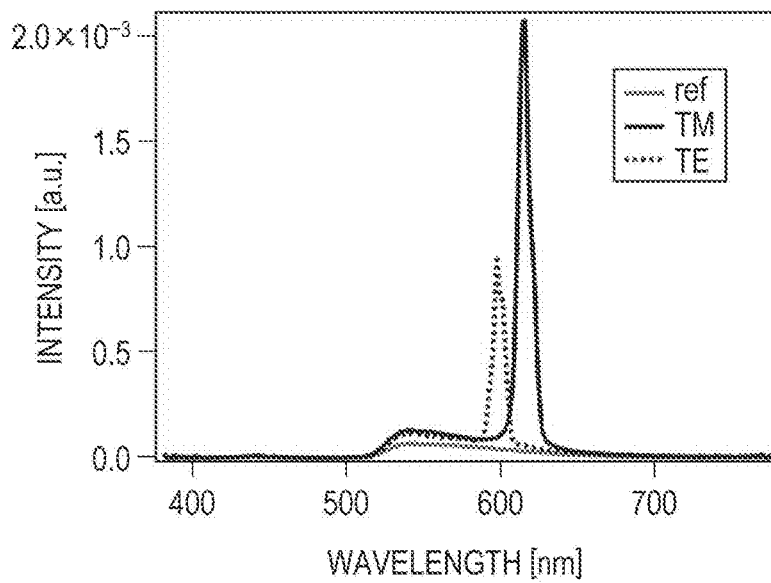

FIG. 27A

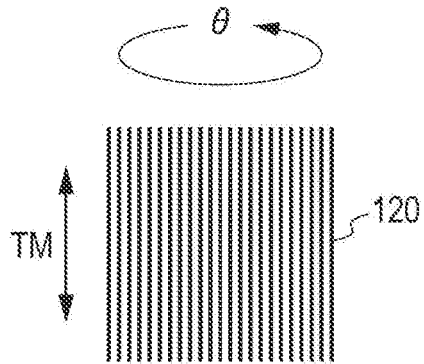

FIG. 27B

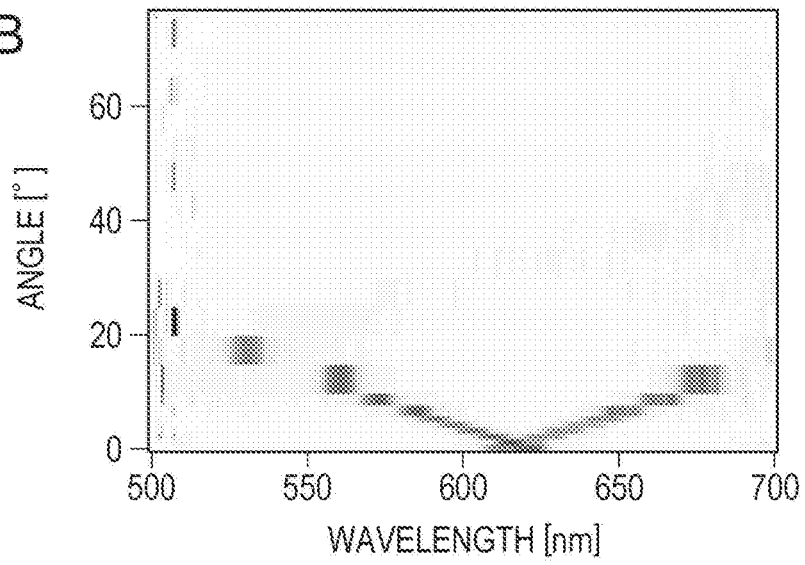

FIG. 27C

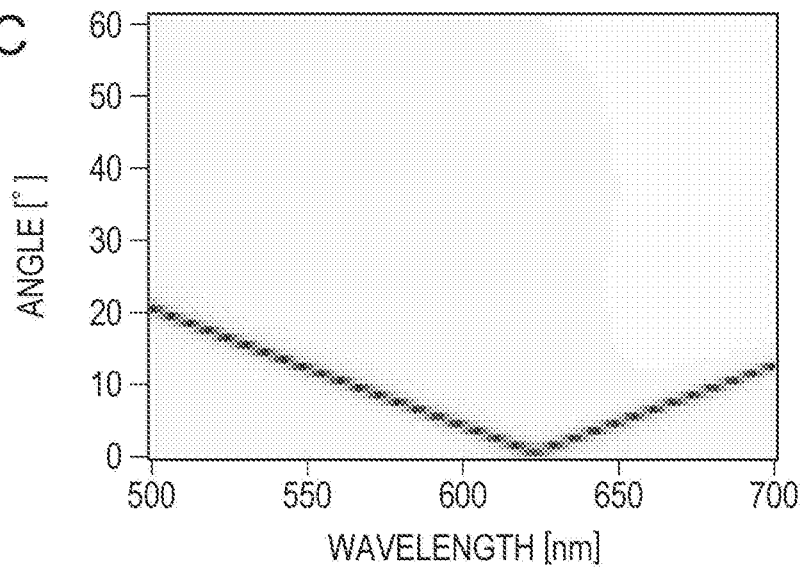

FIG. 27D

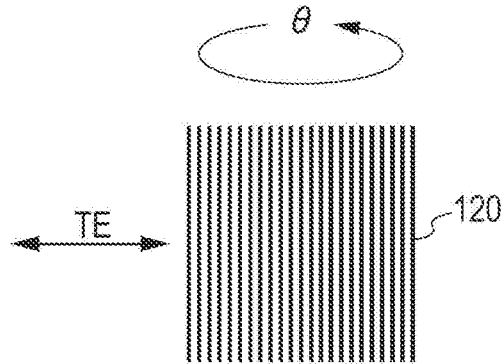

FIG. 27E

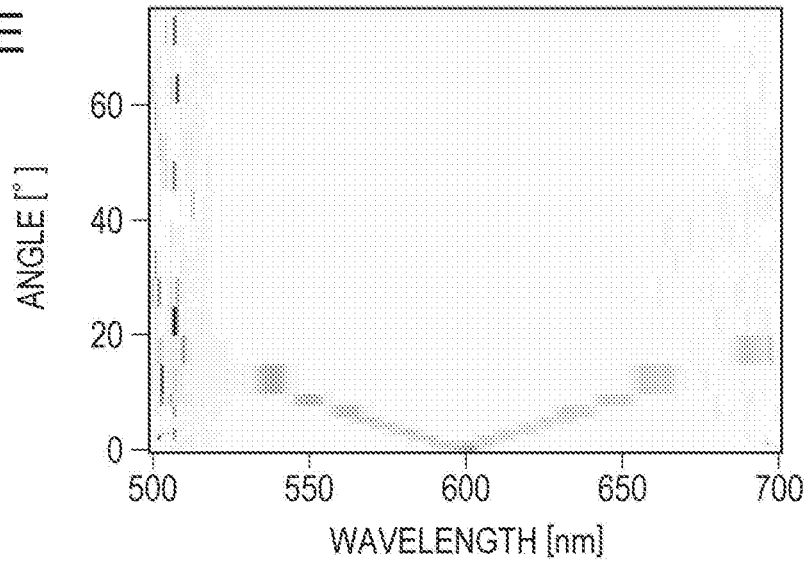

FIG. 27F

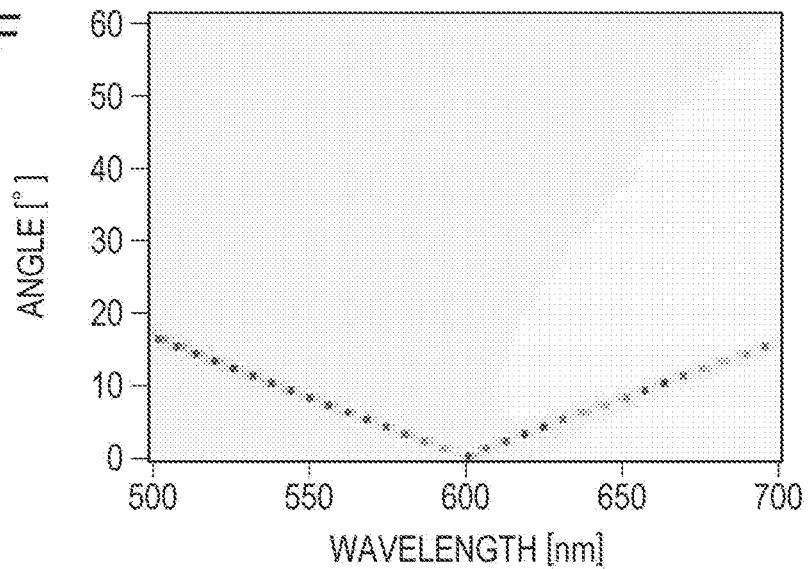

FIG. 28A

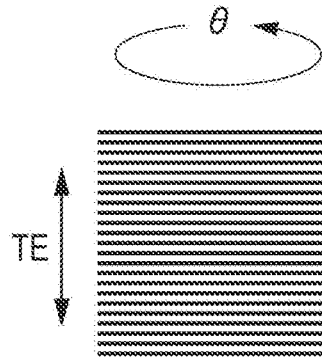

FIG. 28B

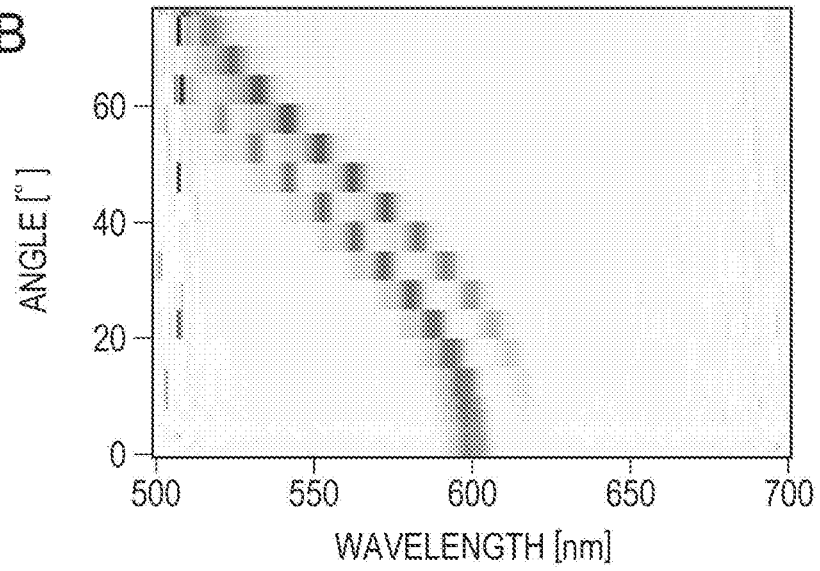

FIG. 28C

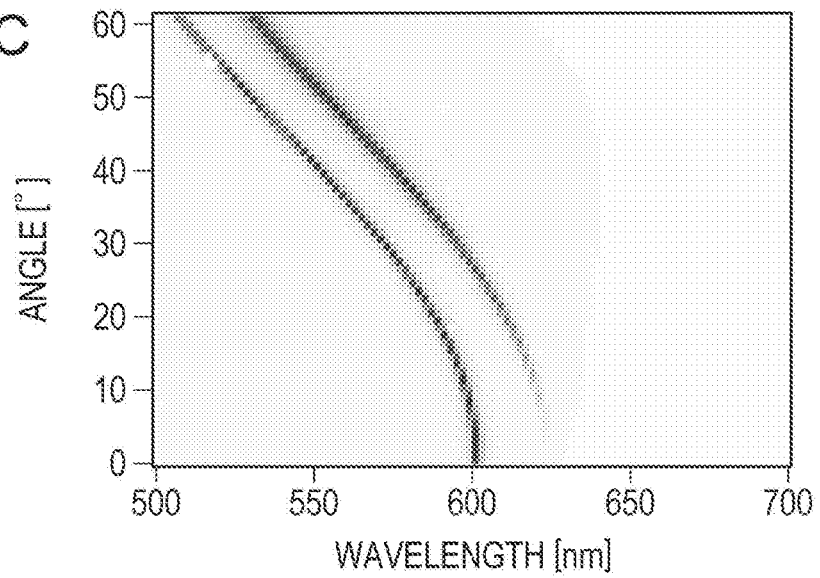

FIG. 28D

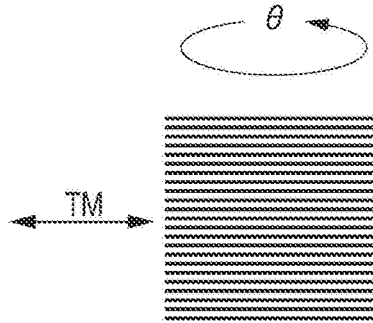

FIG. 28E

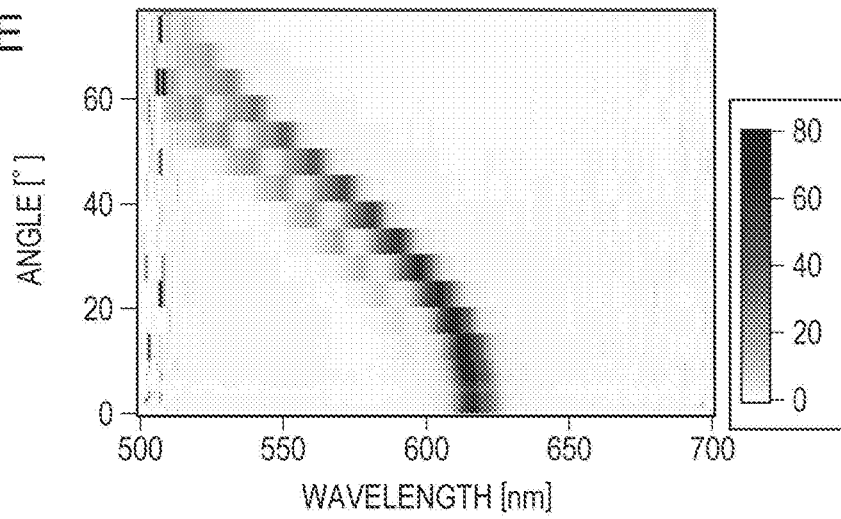

FIG. 28F

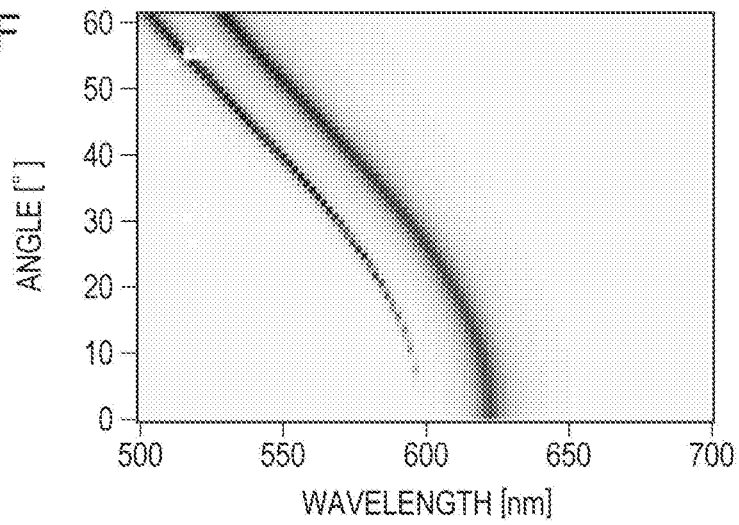

FIG. 29

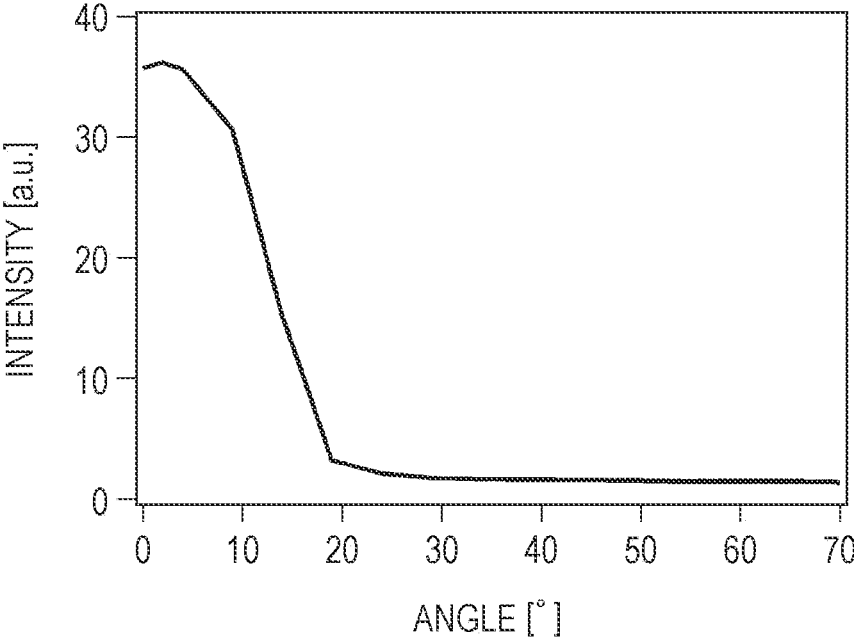

FIG. 30

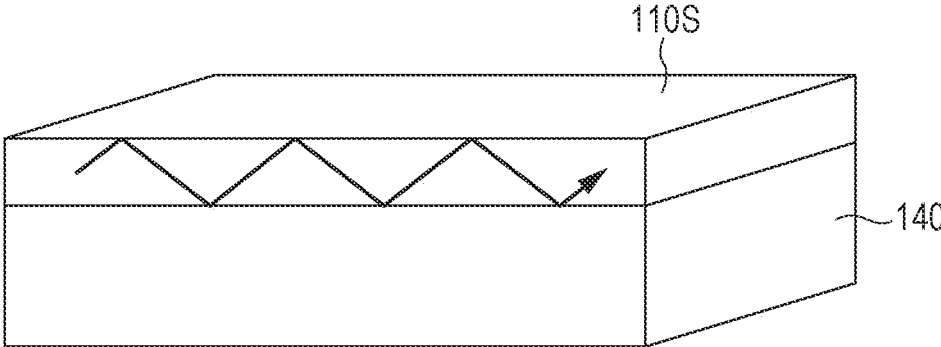

FIG. 31

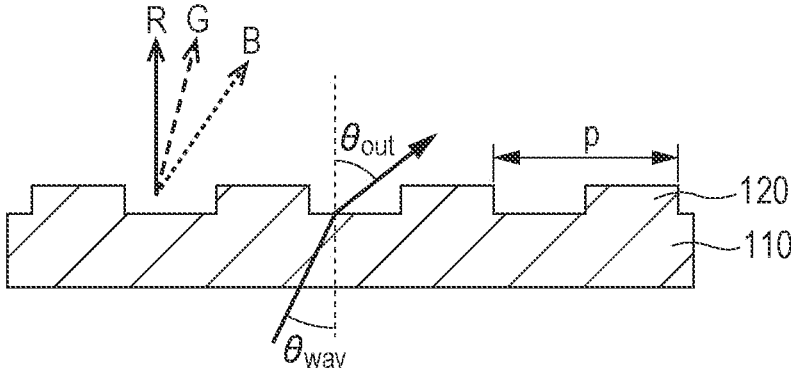

FIG. 32A

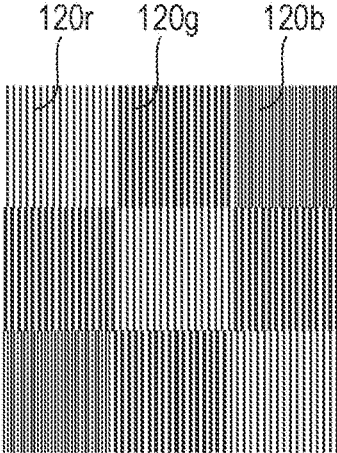

FIG. 32B

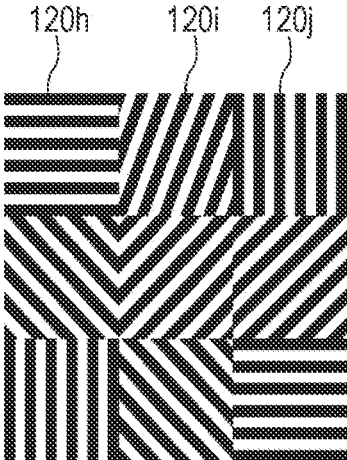

FIG. 32C

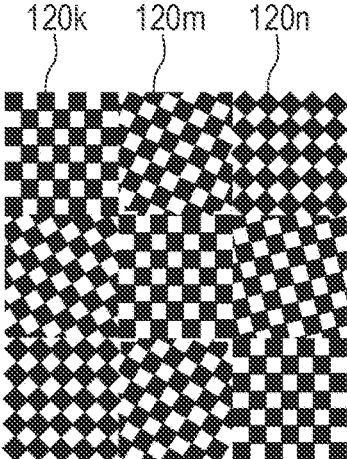

FIG. 33

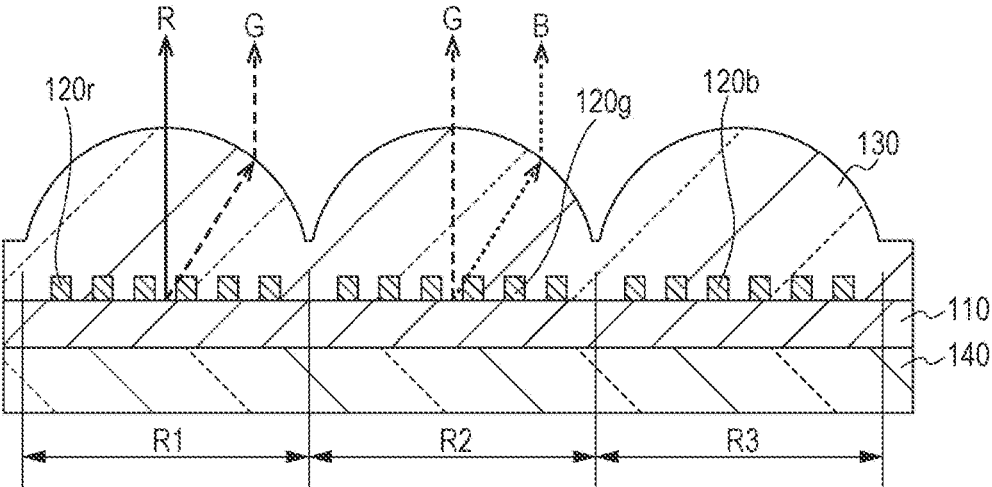

FIG. 34A

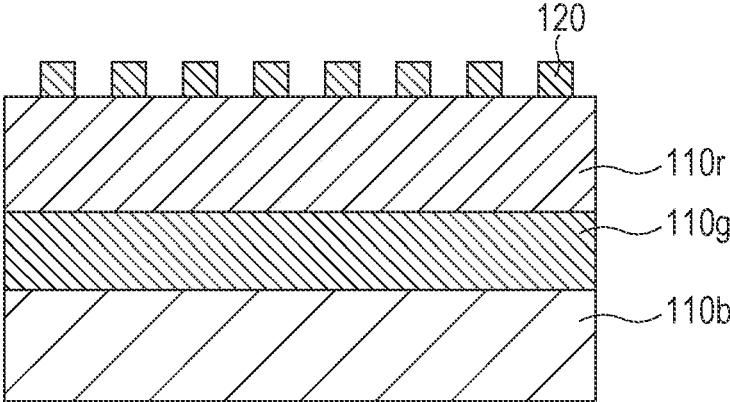
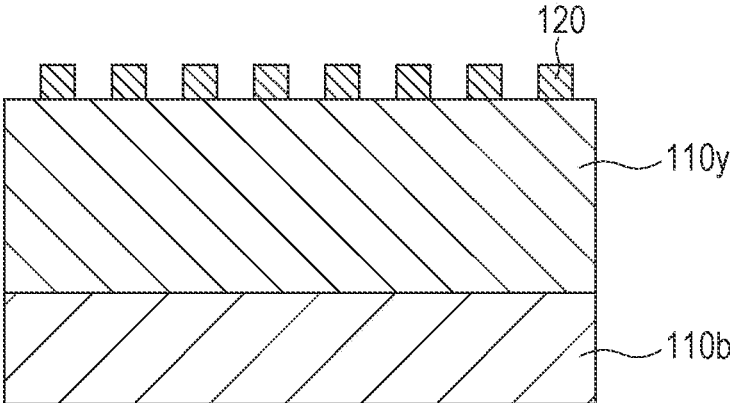

FIG. 34B



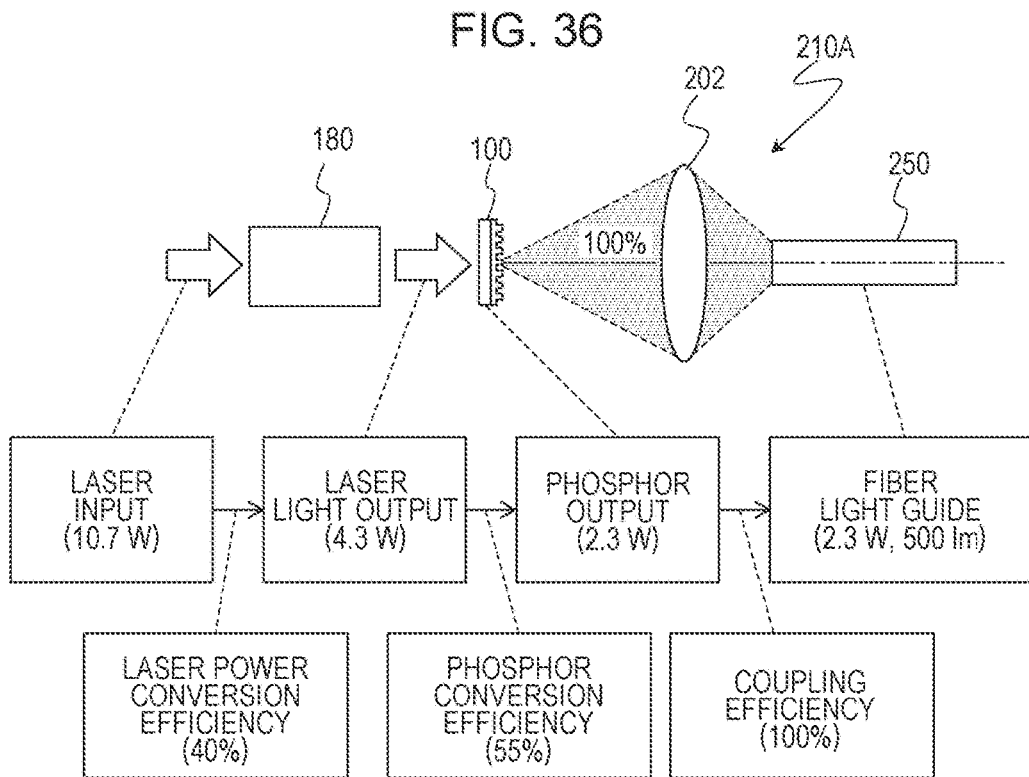
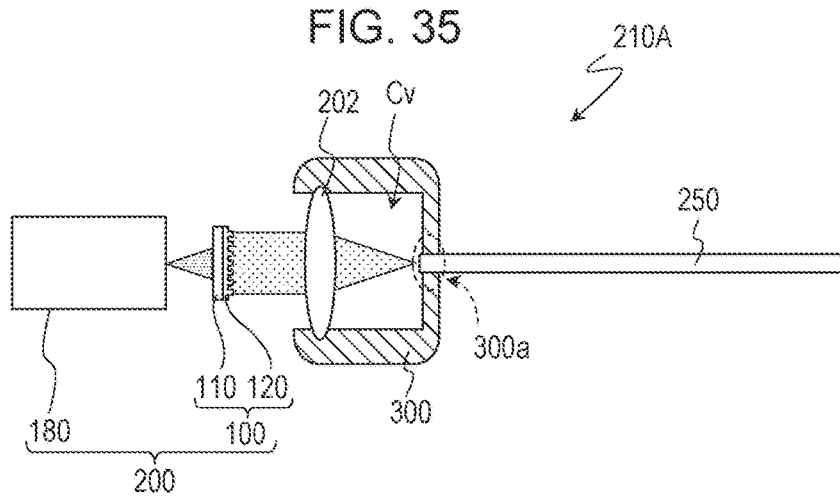

FIG. 37

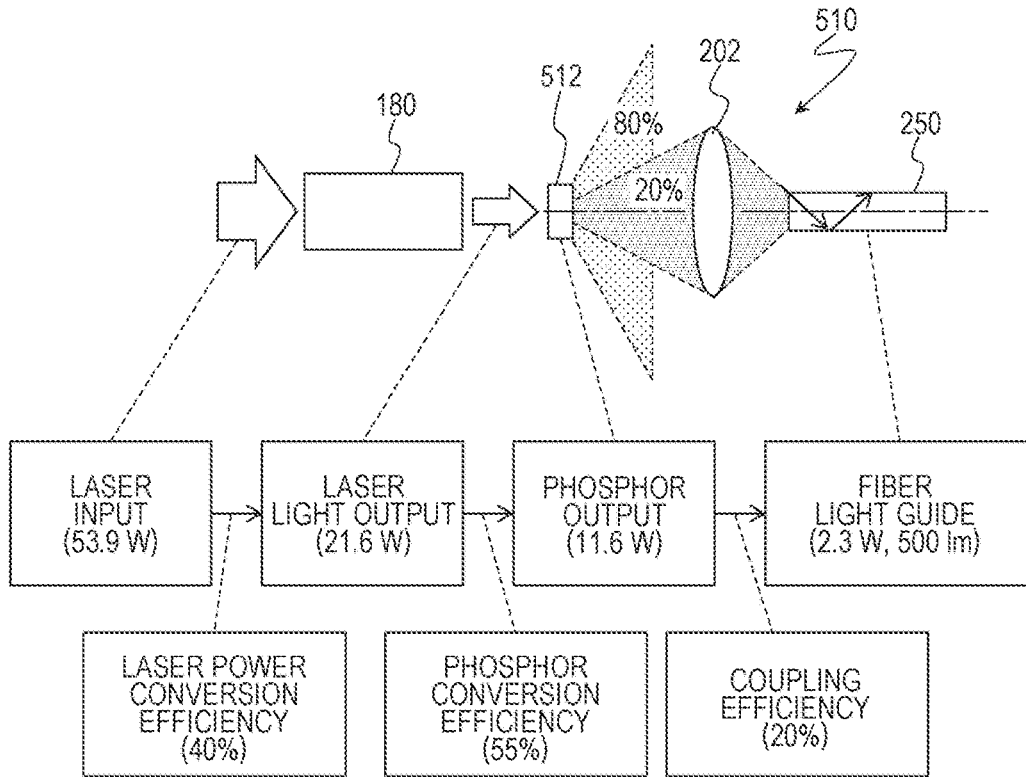

FIG. 38

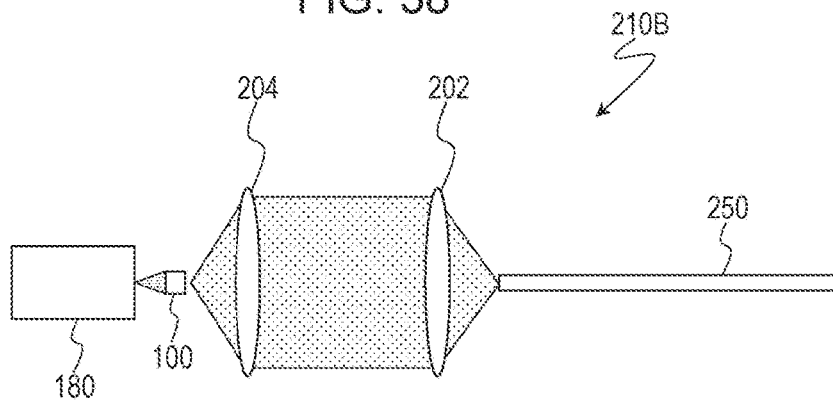

FIG. 39

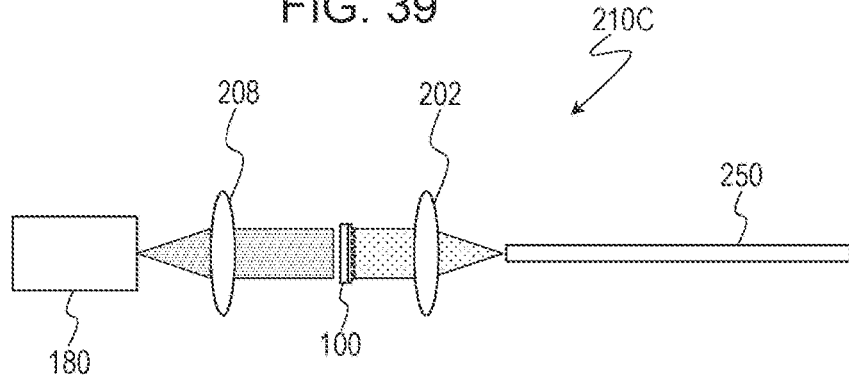

FIG. 40

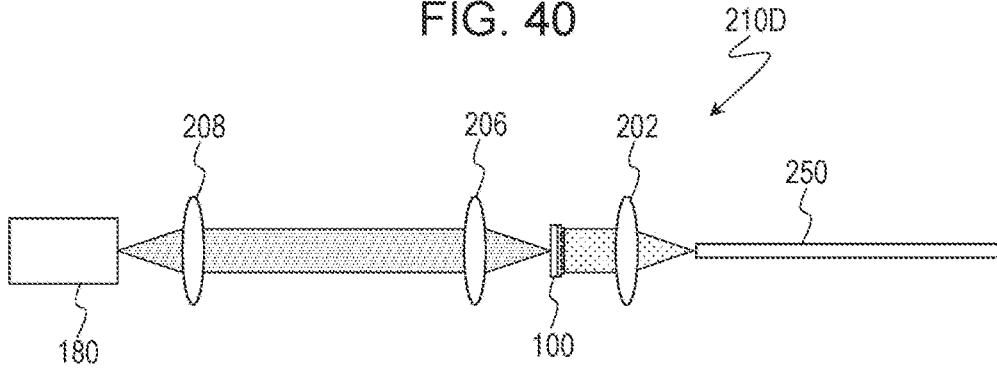

FIG. 41

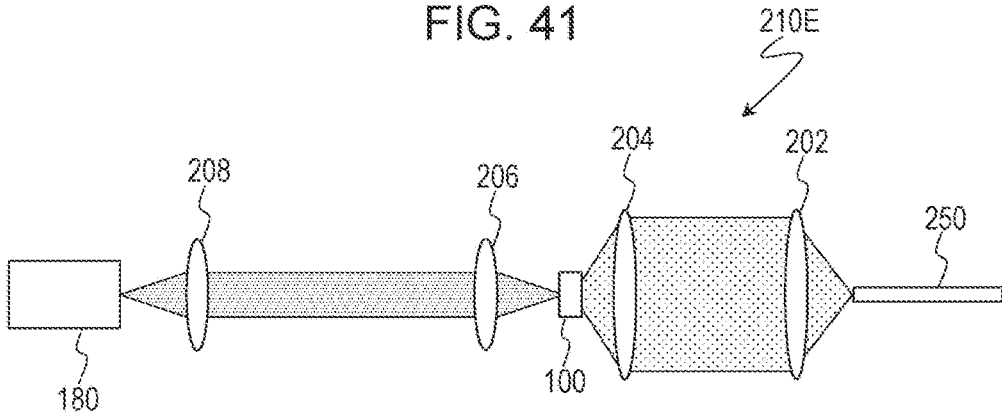

FIG. 42

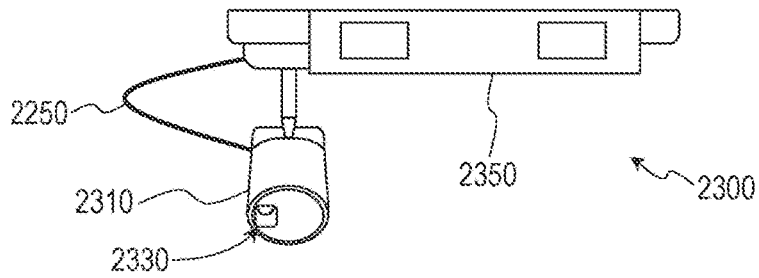

FIG. 43

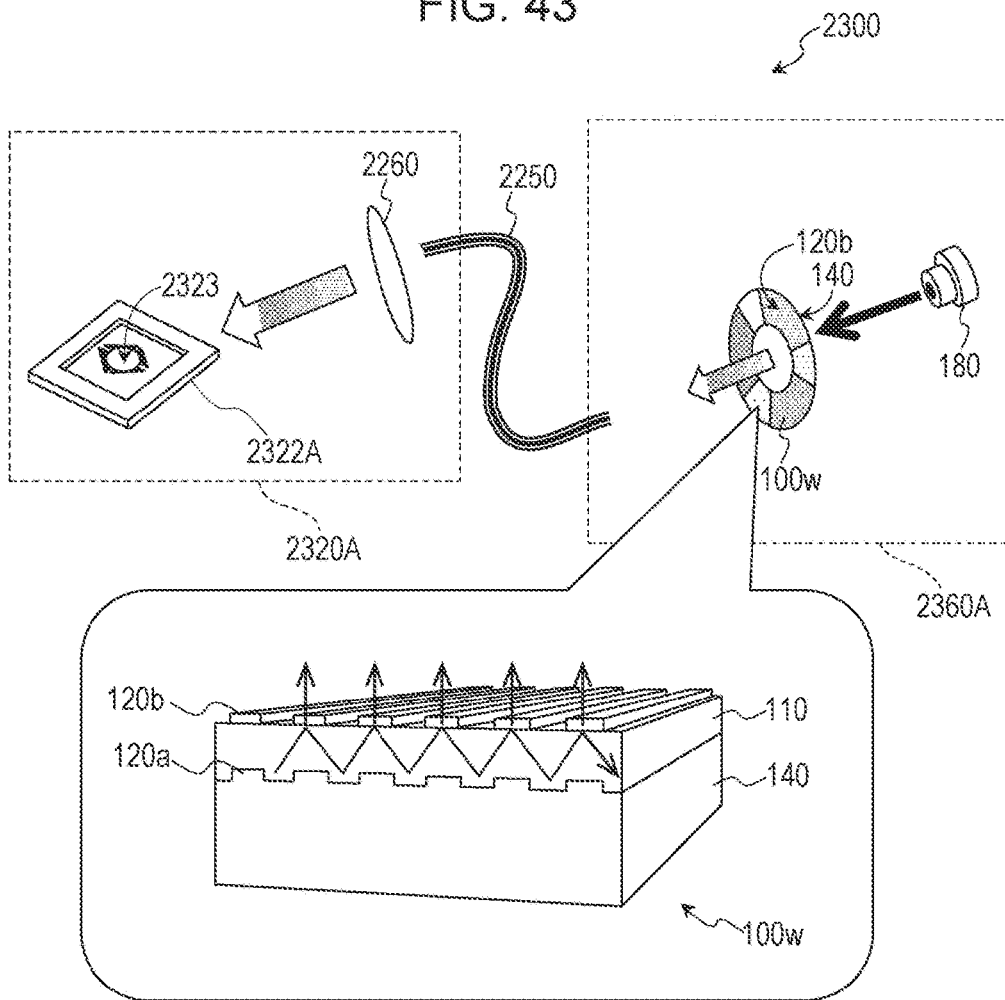

FIG. 44

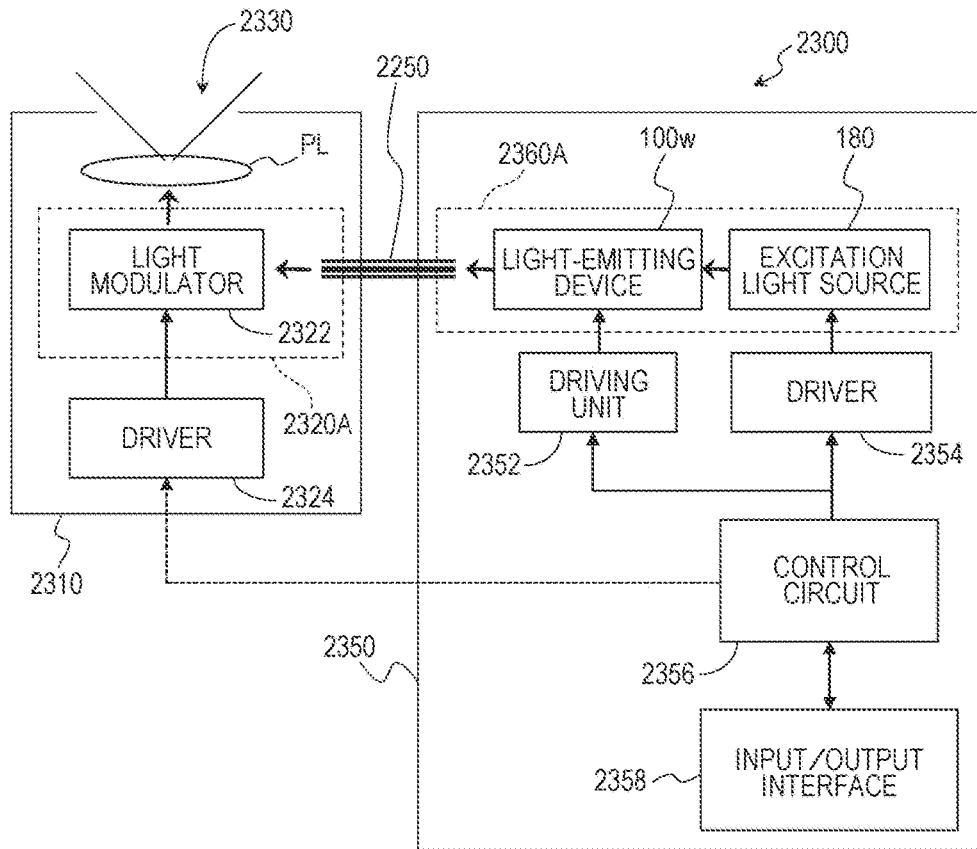

FIG. 45A

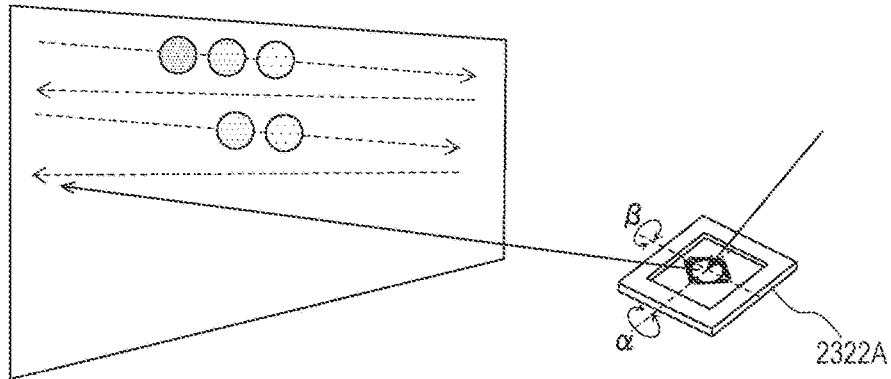

FIG. 45B

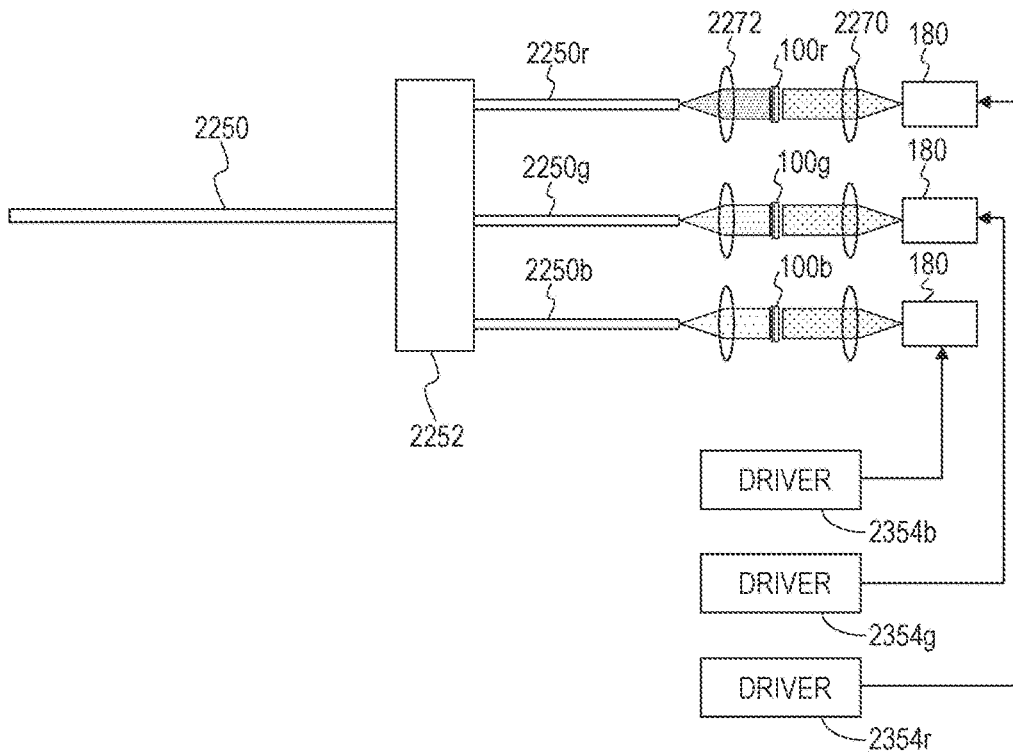

FIG. 46

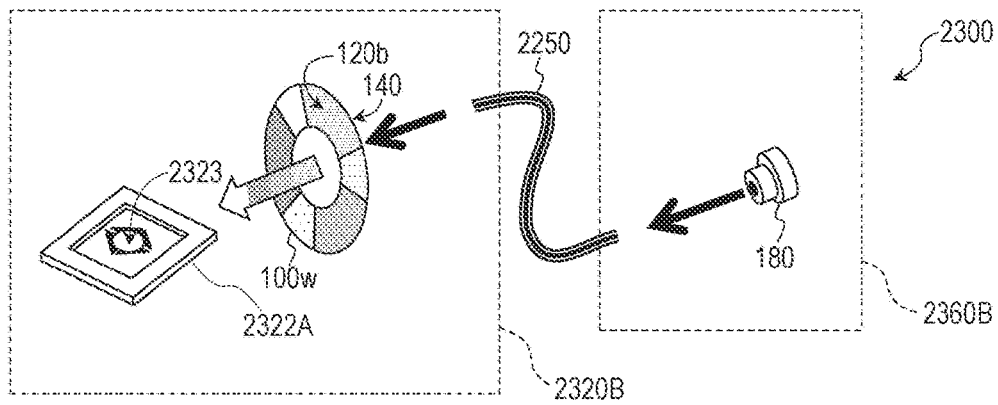

FIG. 47

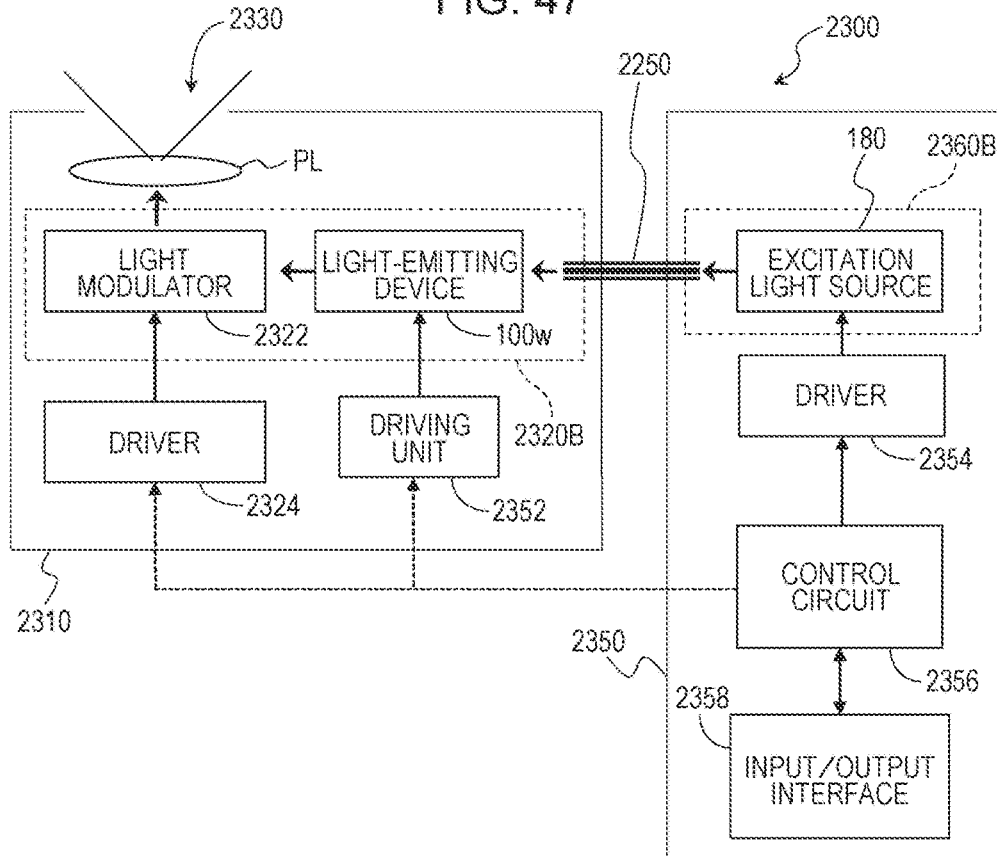

FIG. 48

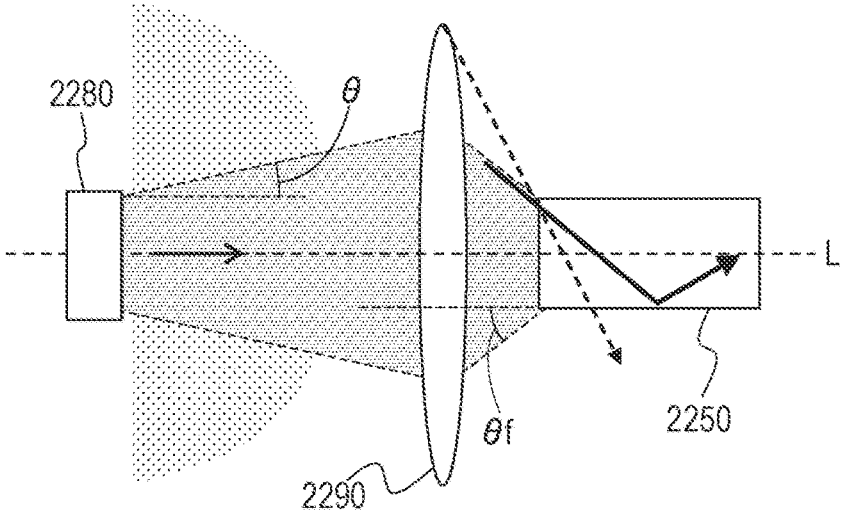

FIG. 49

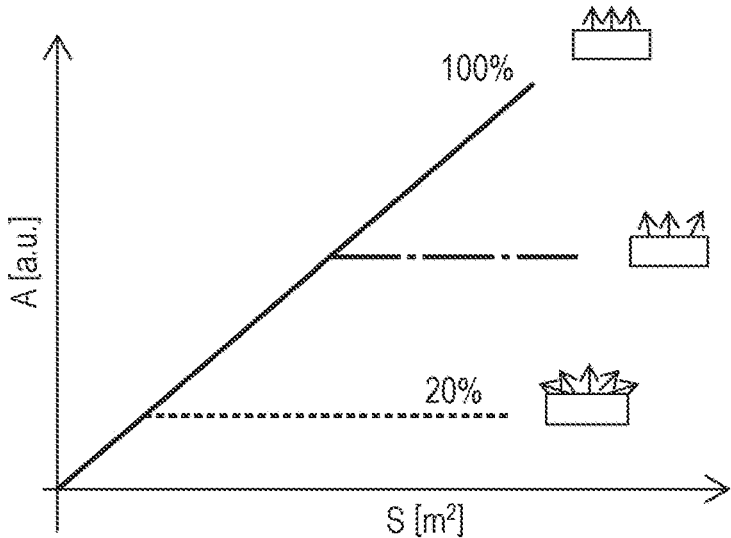

FIG. 50

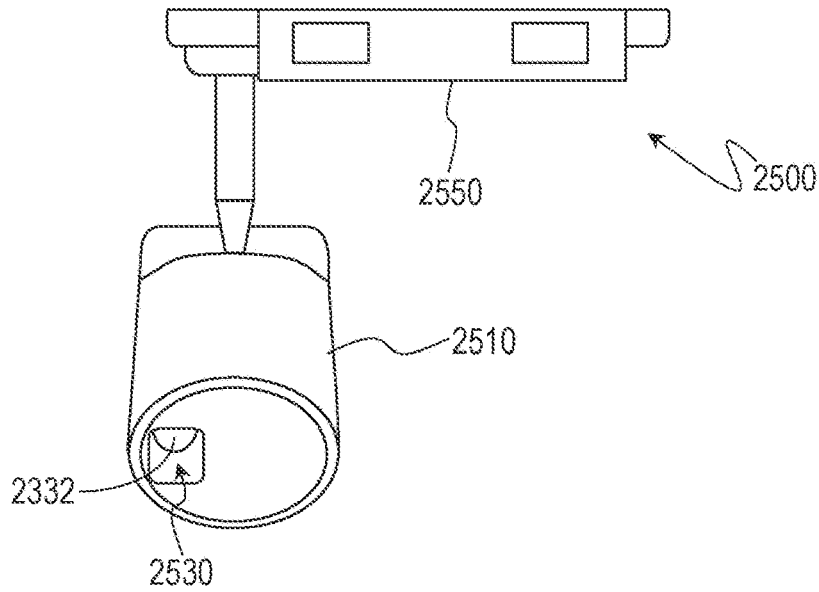

FIG. 51

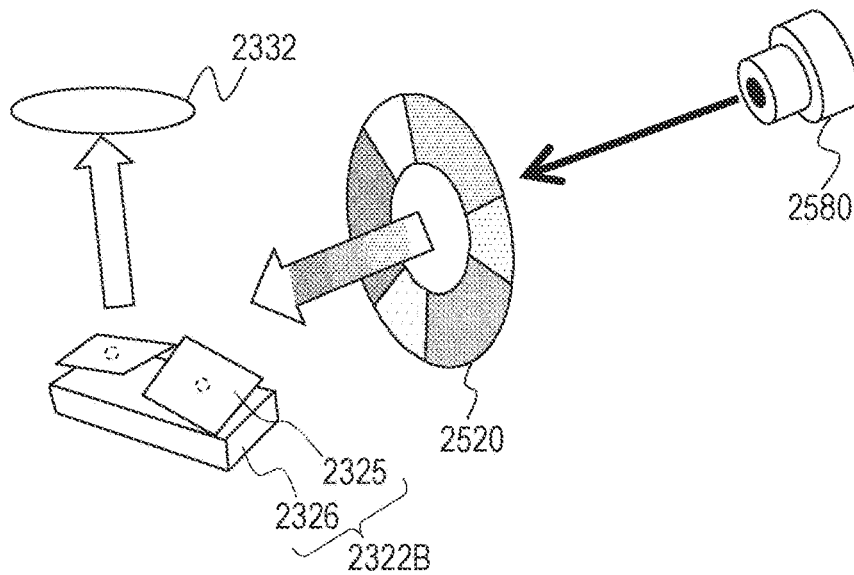

FIG. 52

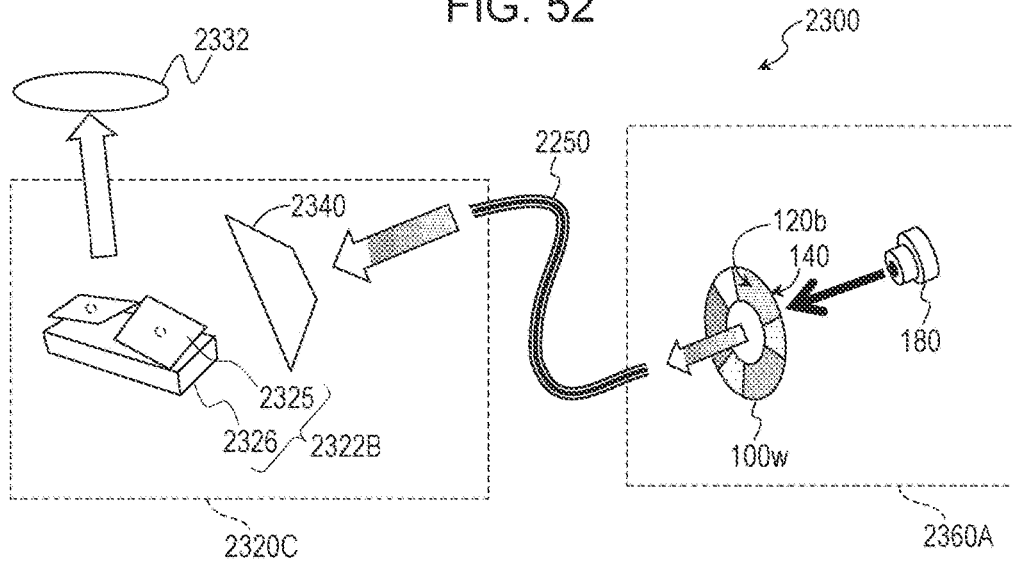

FIG. 53

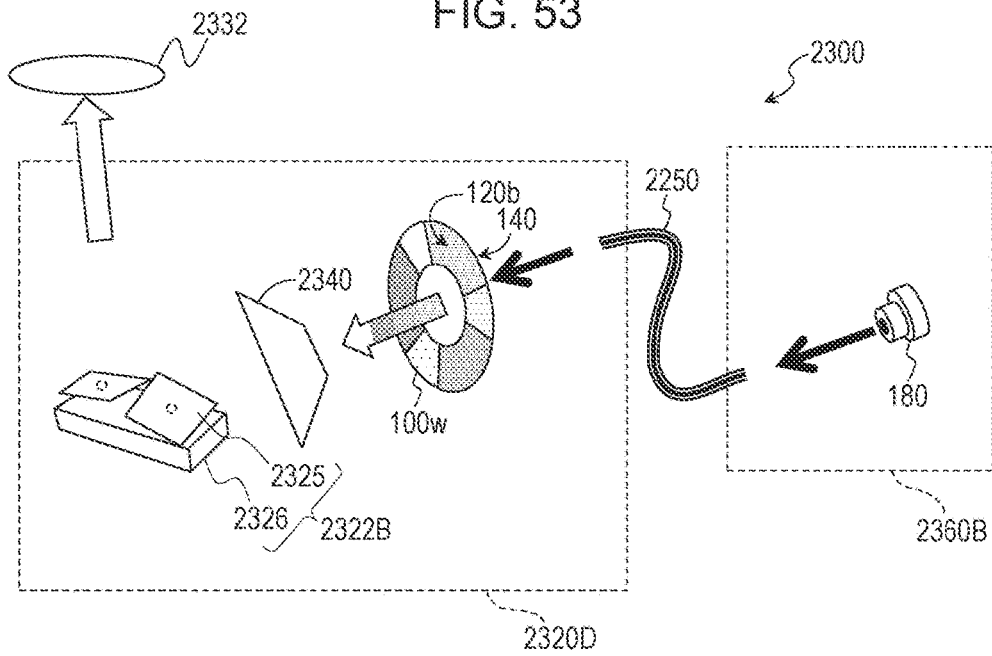

FIG. 54A

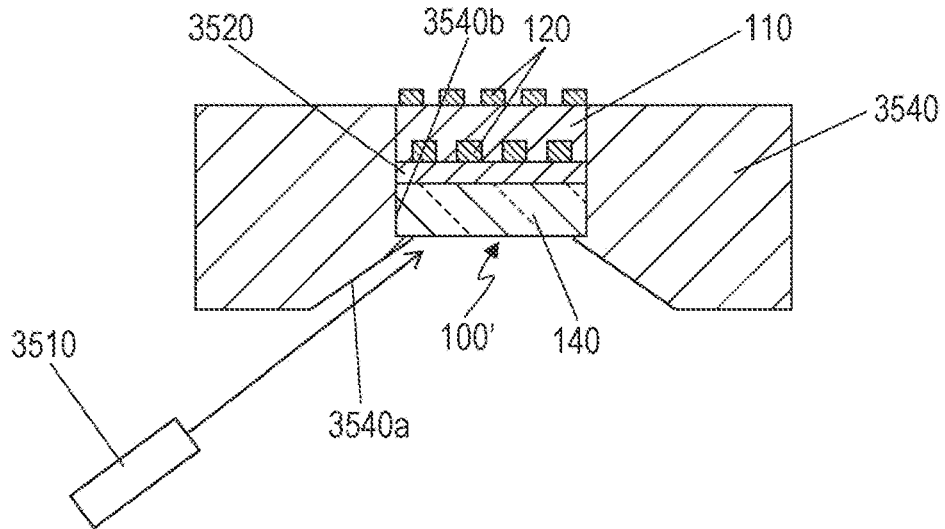

FIG. 54B

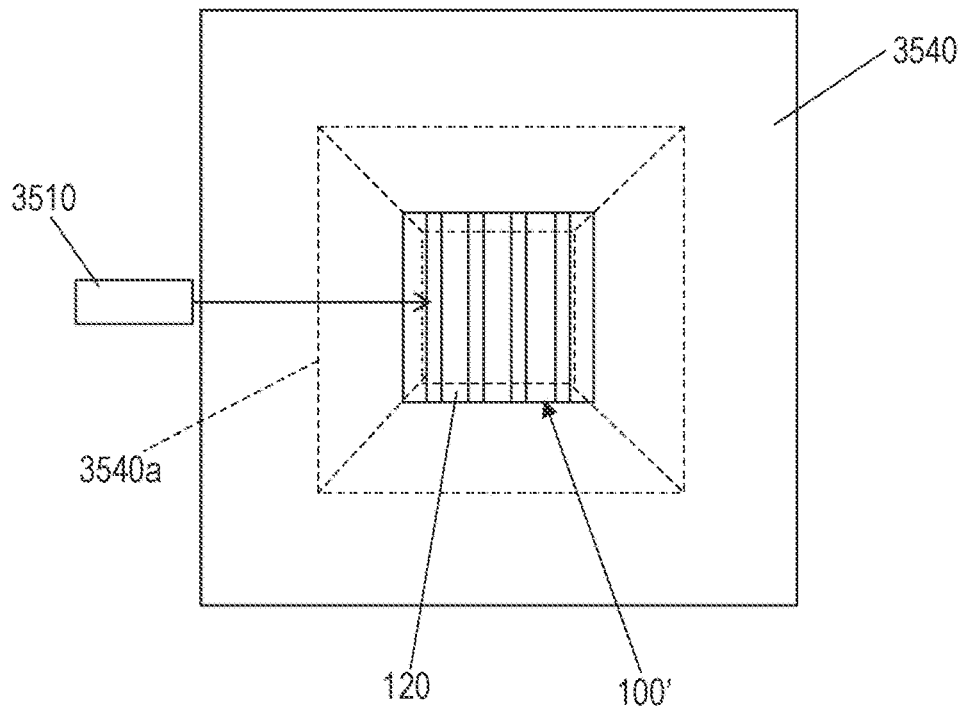

FIG. 54C

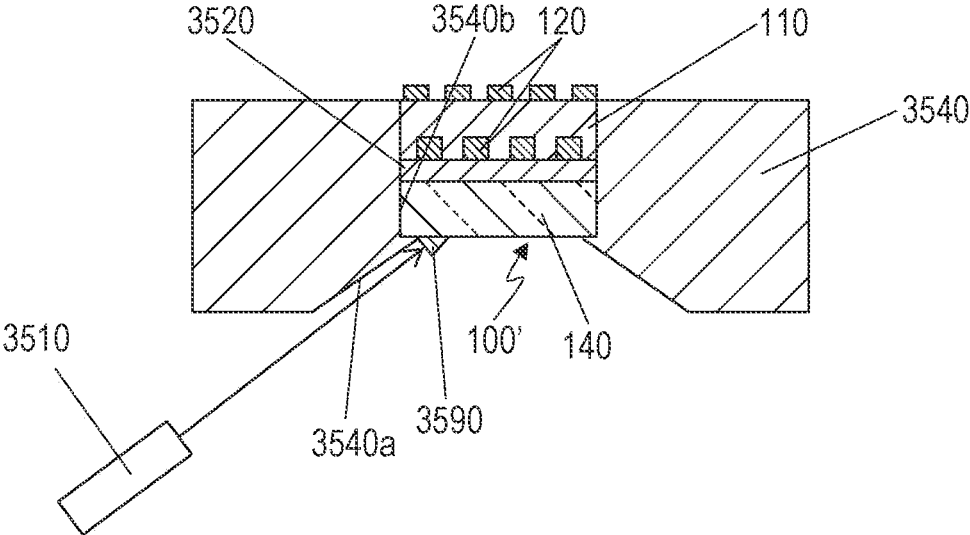

FIG. 55A

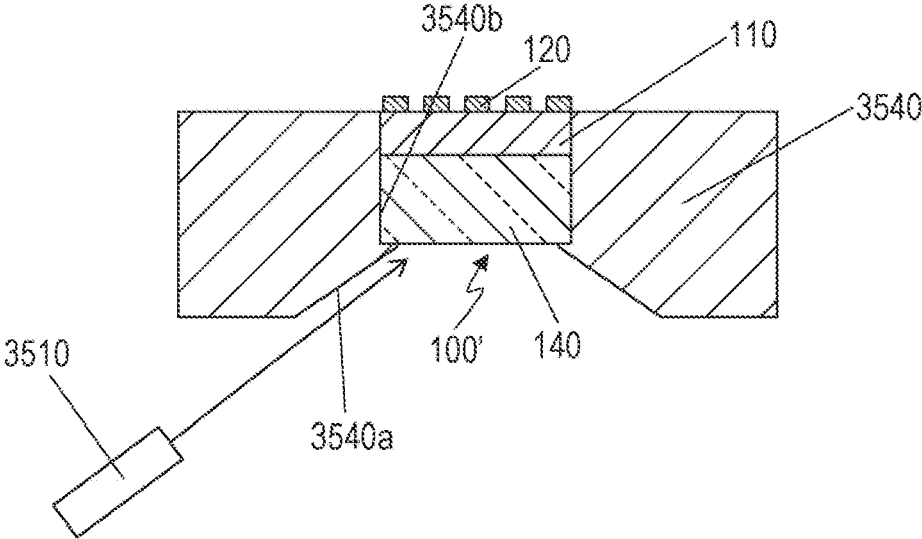

FIG. 55B

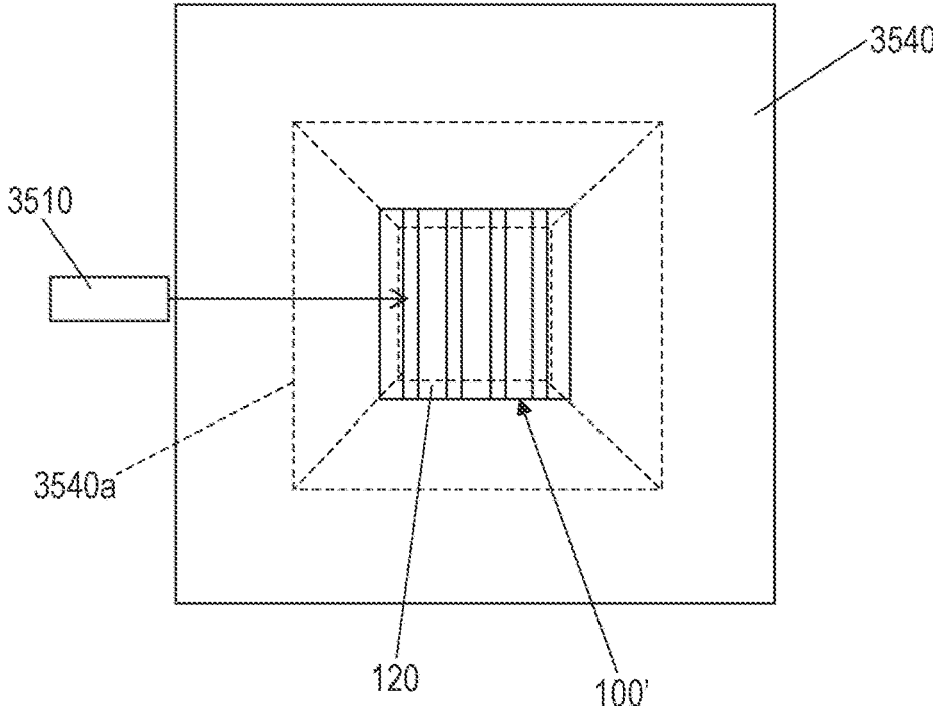

FIG. 56A

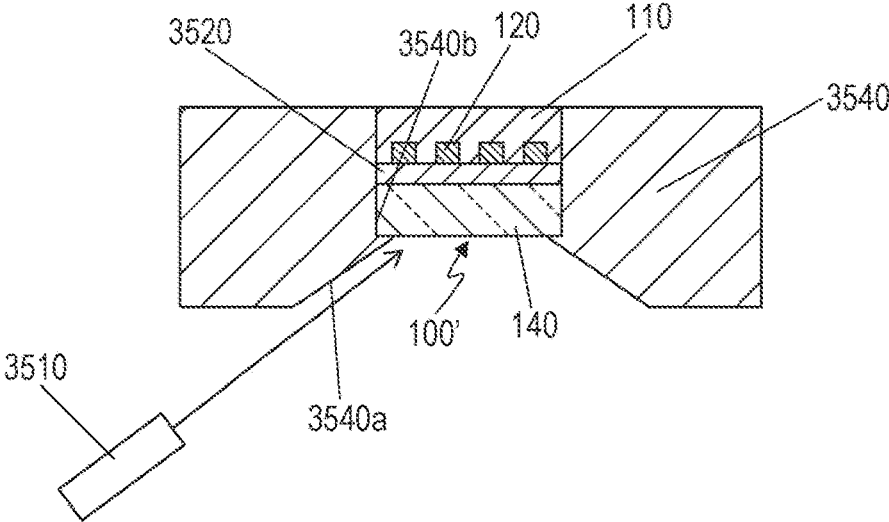

FIG. 56B

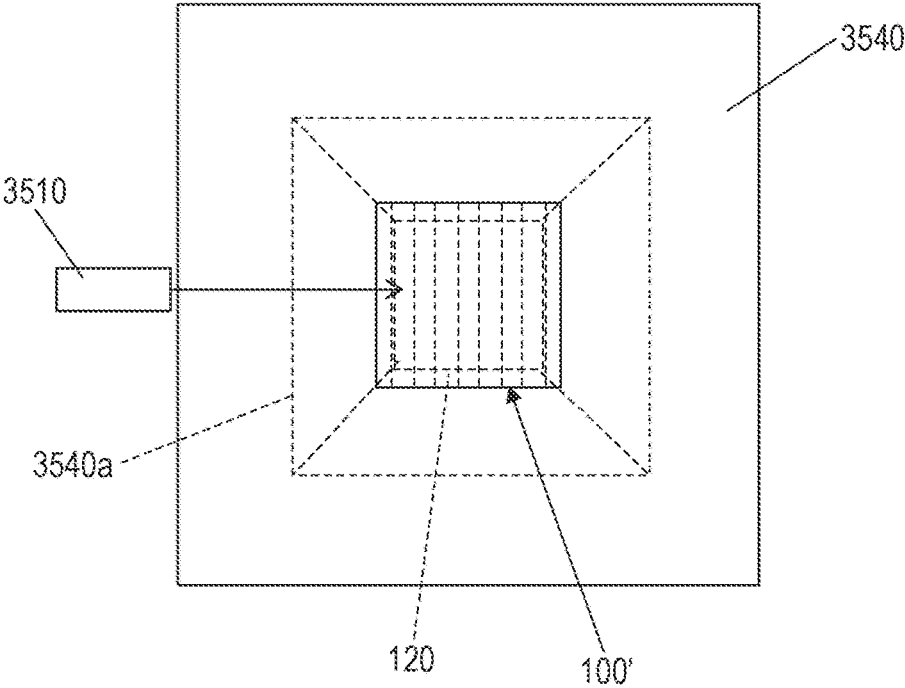

FIG. 57A

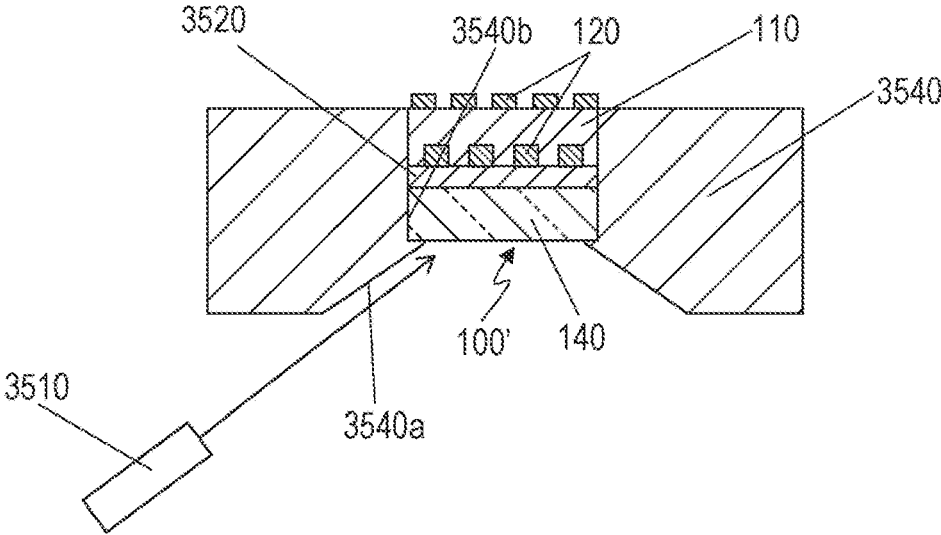

FIG. 57B

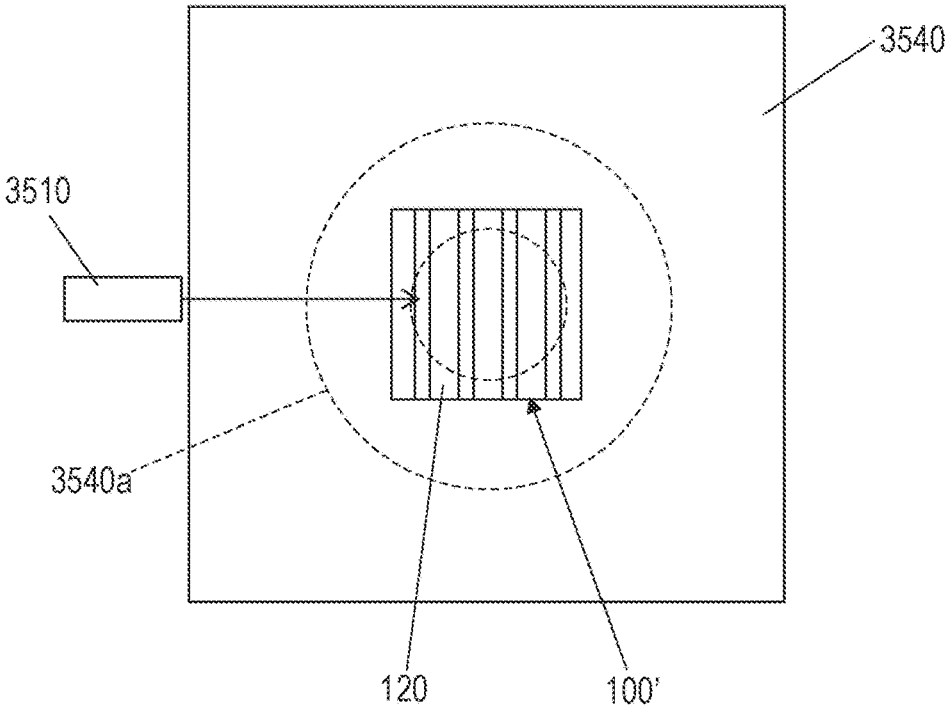

FIG. 58A

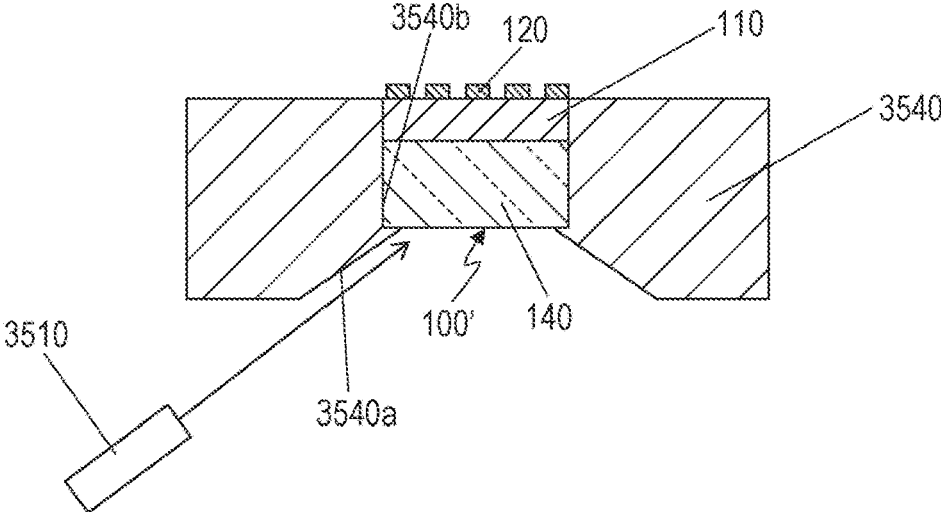

FIG. 58B

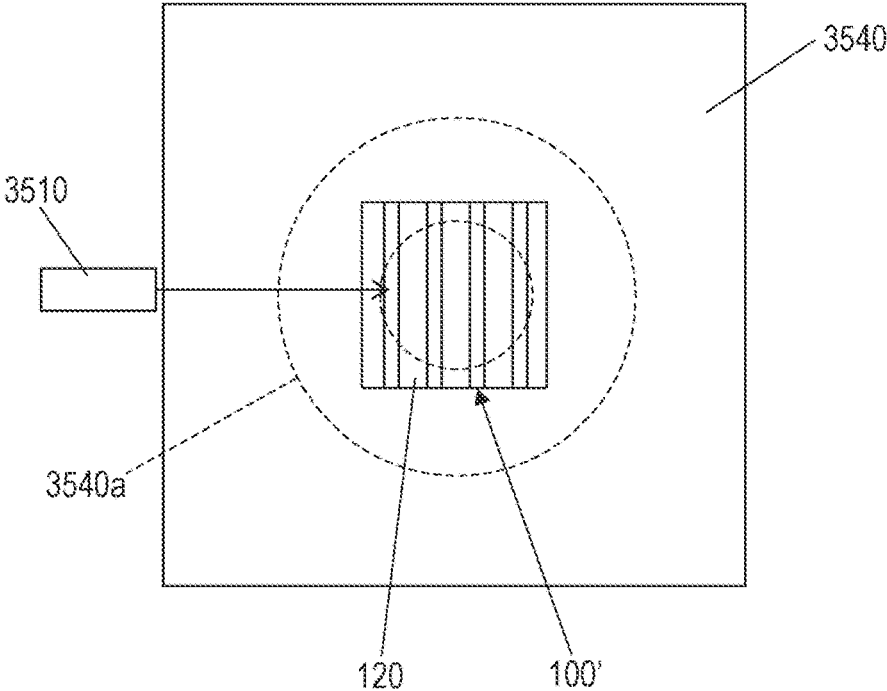

FIG. 59A

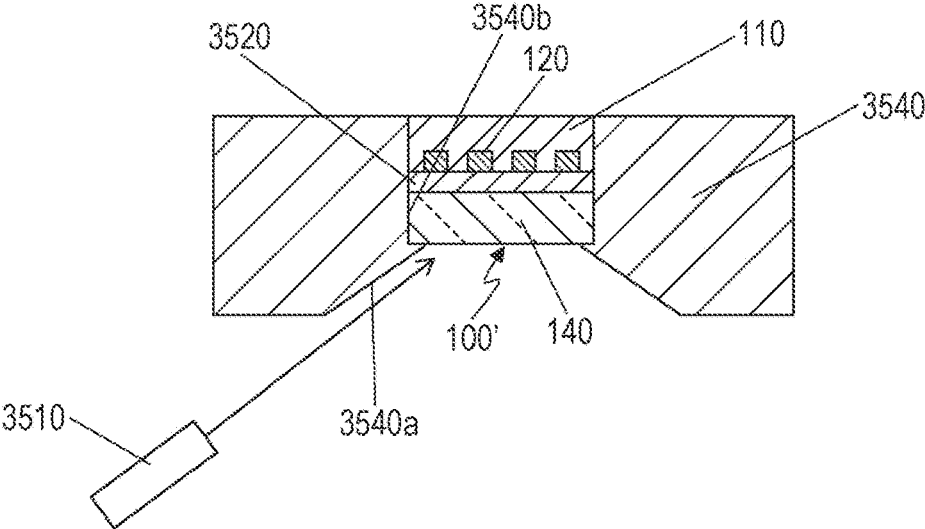

FIG. 59B

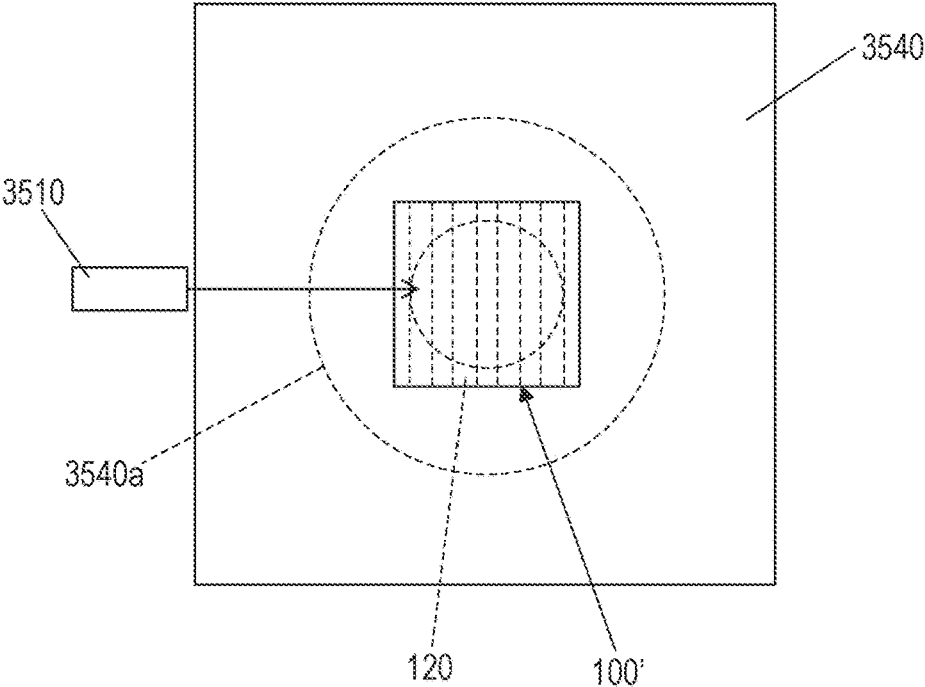

FIG. 60A

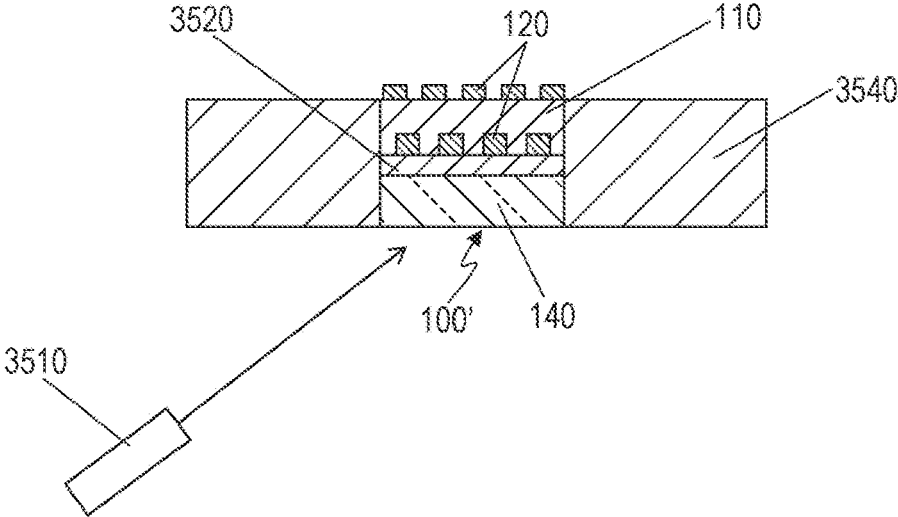

FIG. 60B

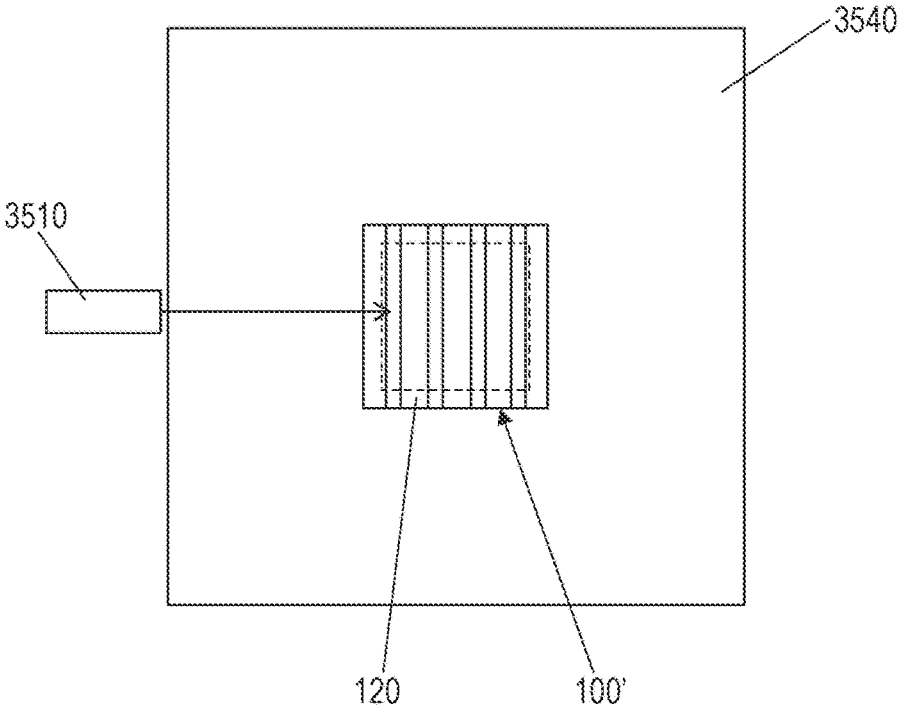

FIG. 61A

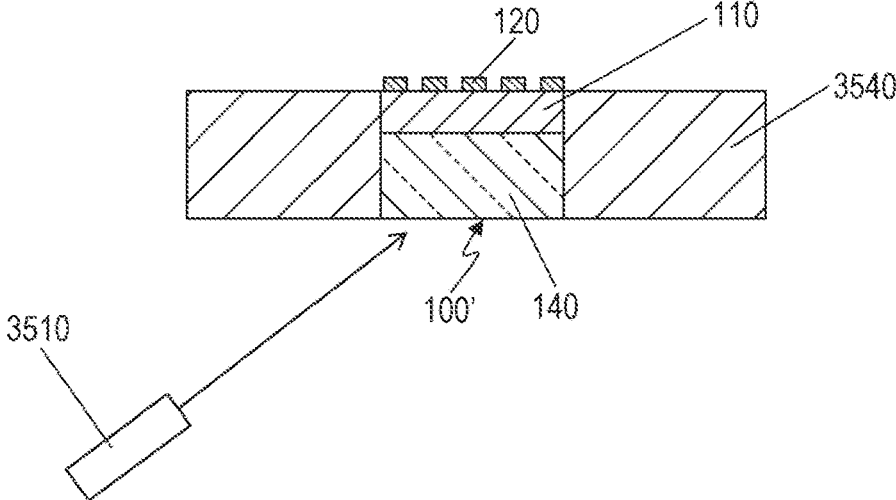

FIG. 61B

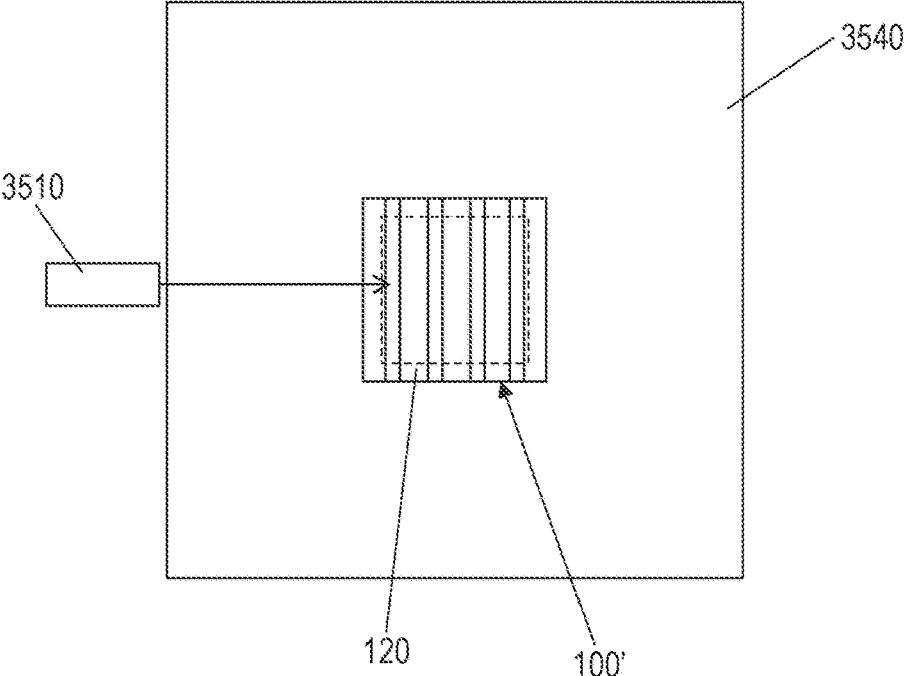

FIG. 62A

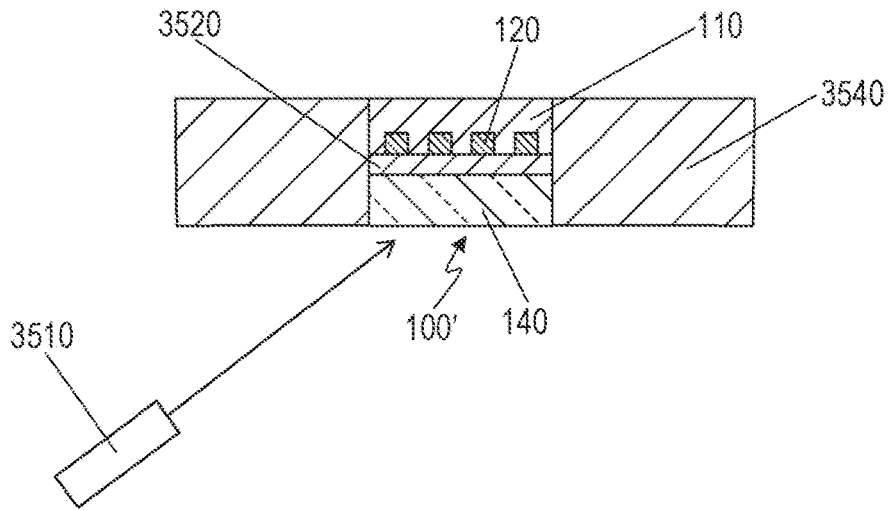

FIG. 62B

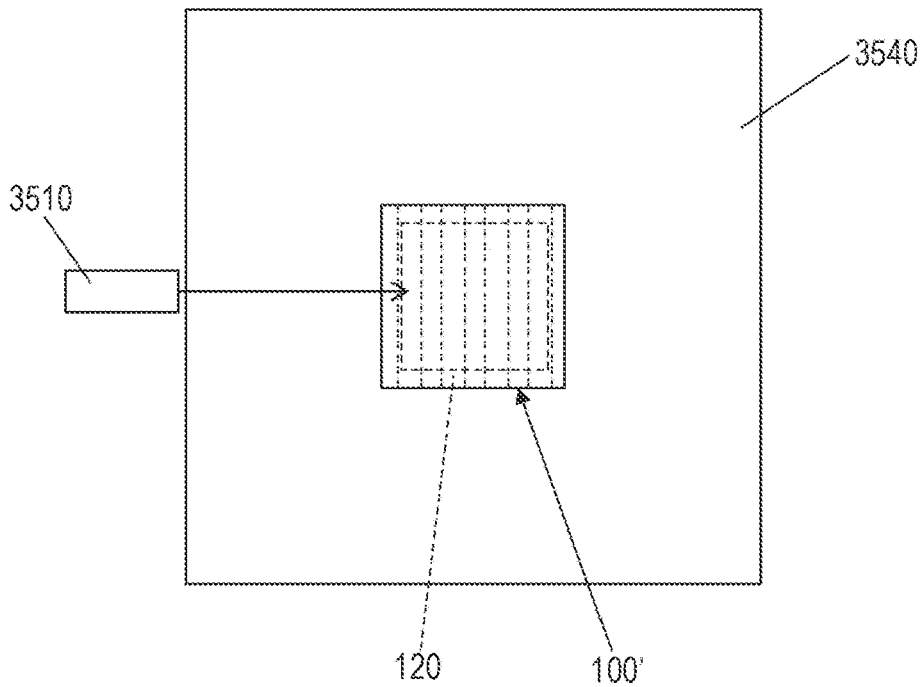

FIG. 63A

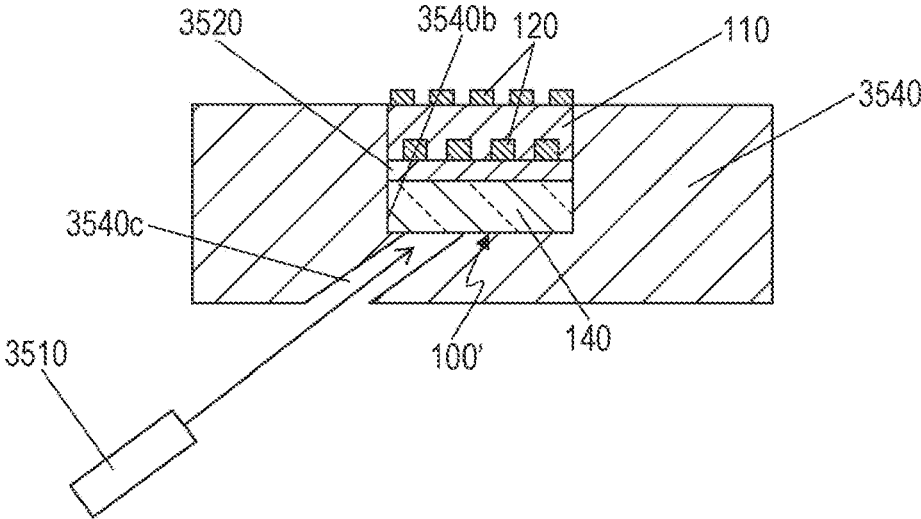

FIG. 63B

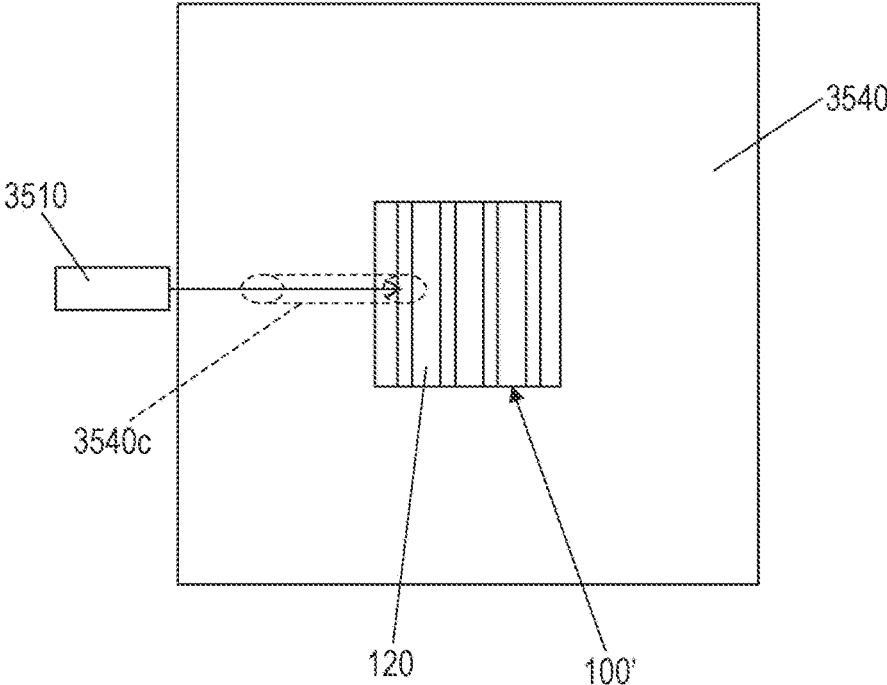

FIG. 64A

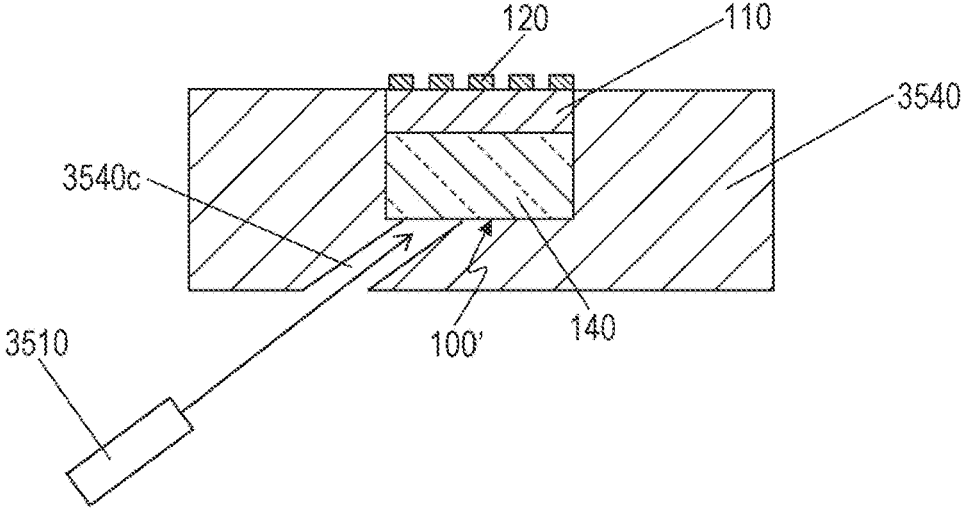

FIG. 64B

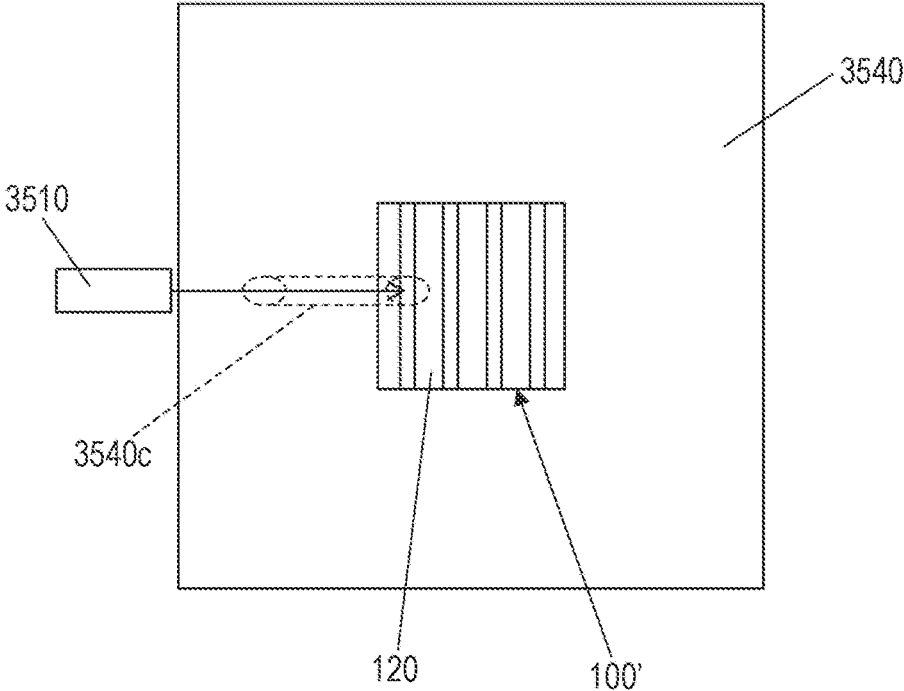

FIG. 65A

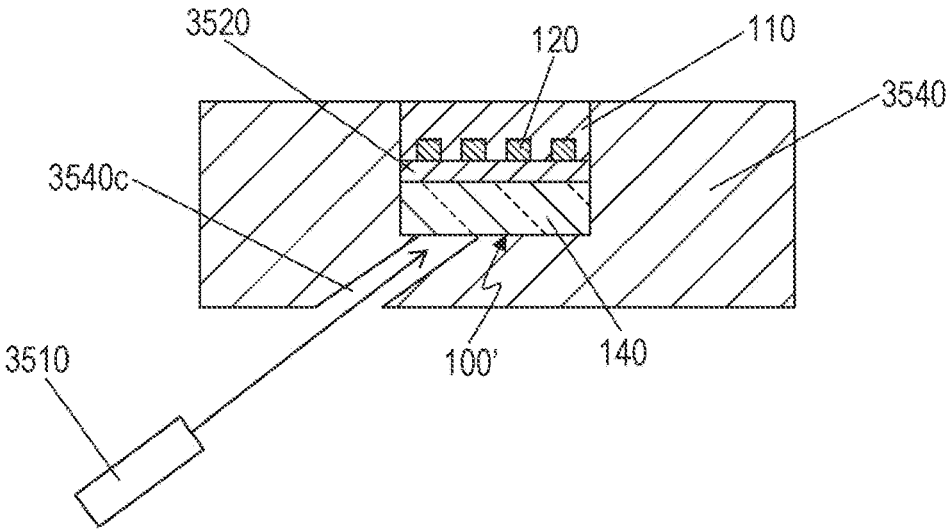

FIG. 65B

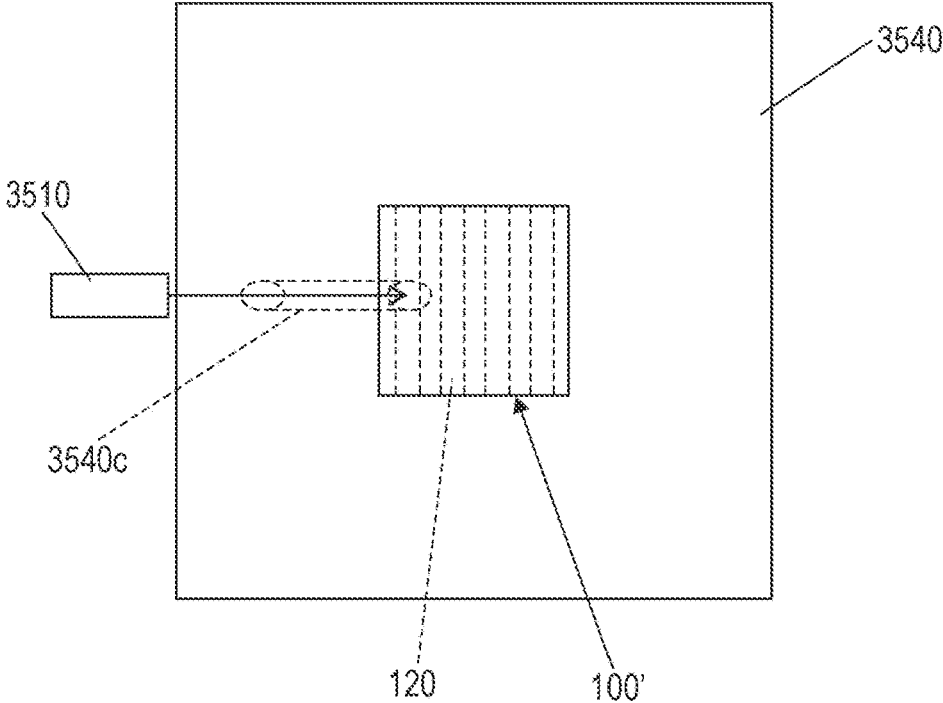

FIG. 66A

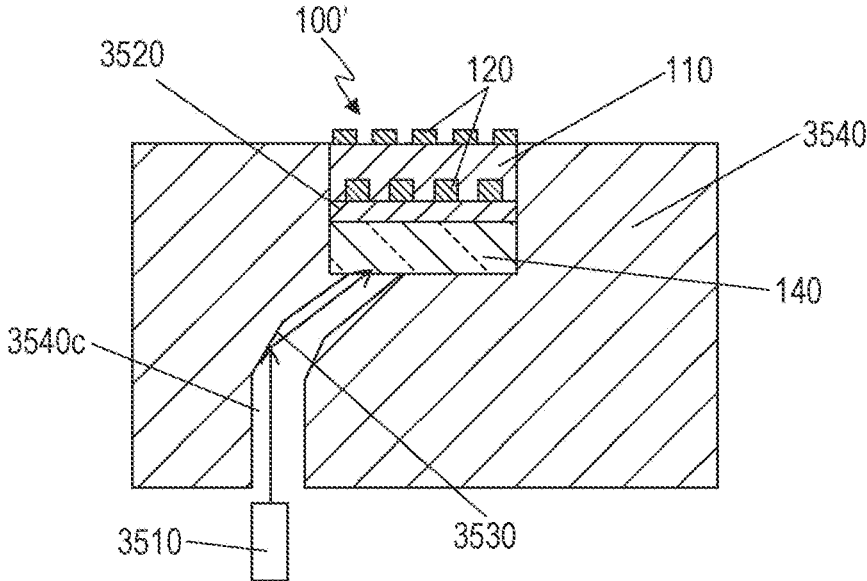

FIG. 66B

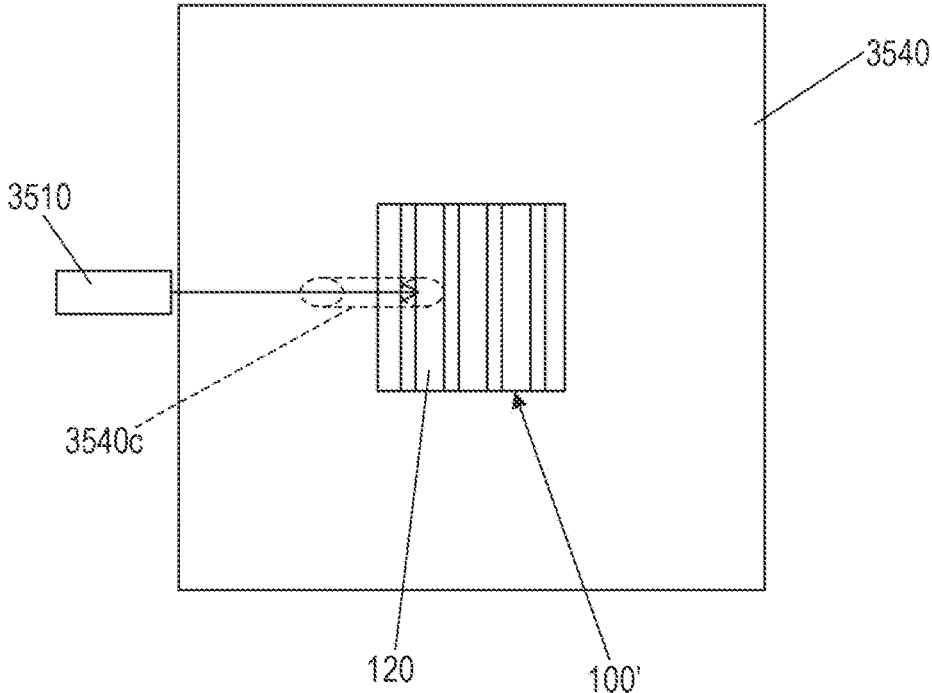

FIG. 67A

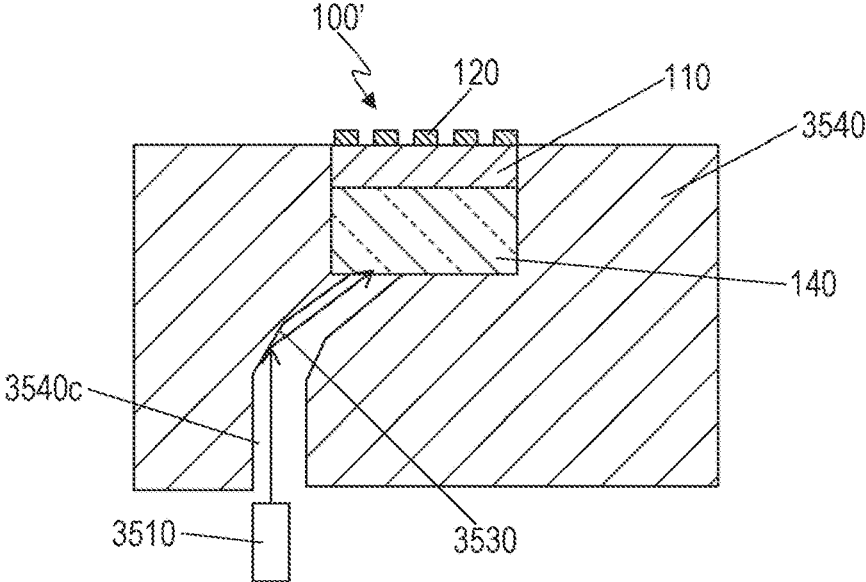

FIG. 67B

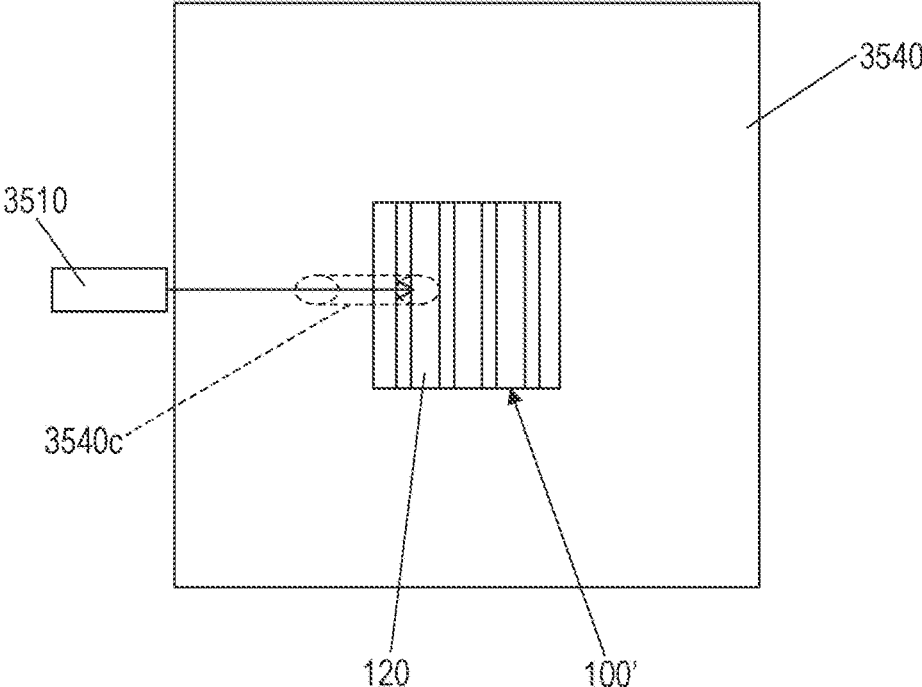

FIG. 68A

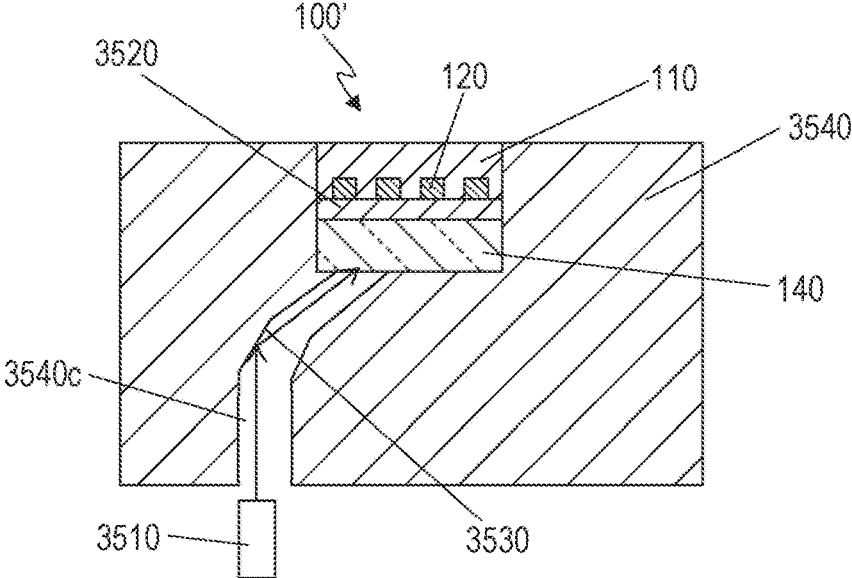

FIG. 68B

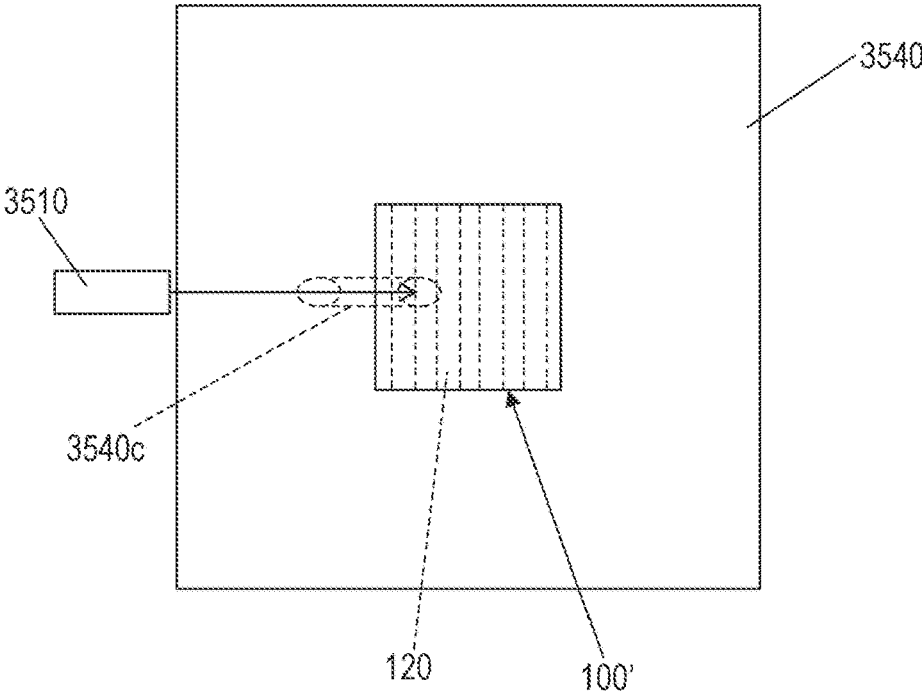

FIG. 69A

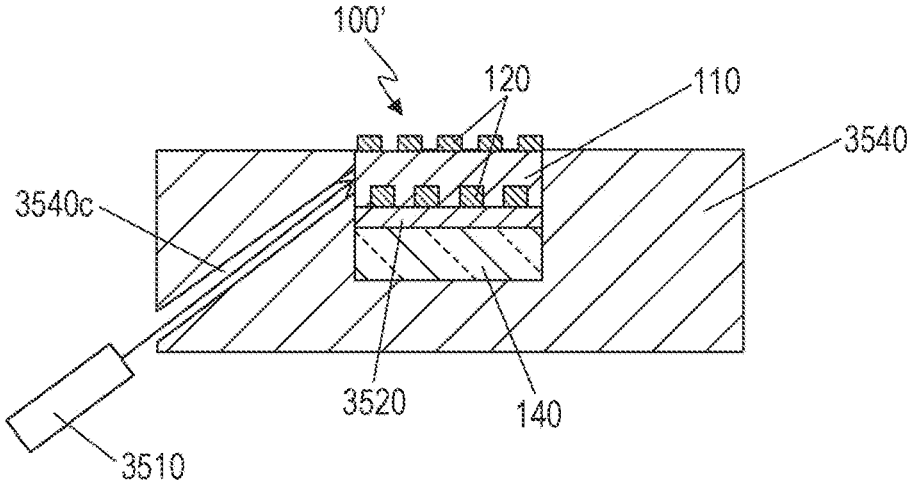

FIG. 69B

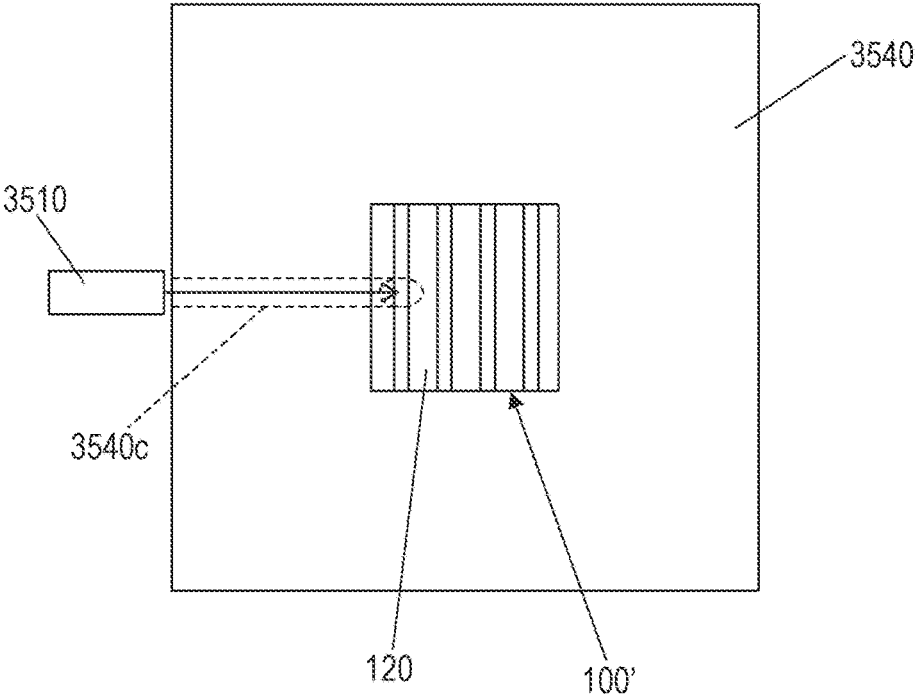

FIG. 70A

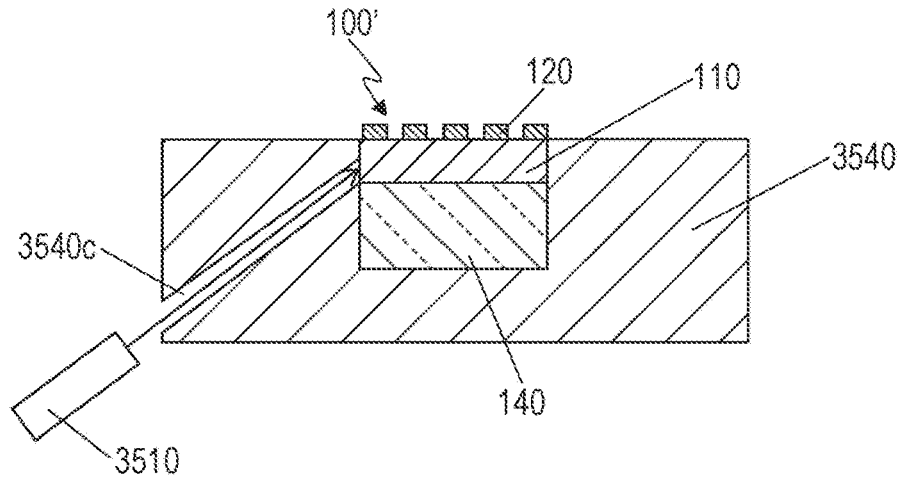

FIG. 70B

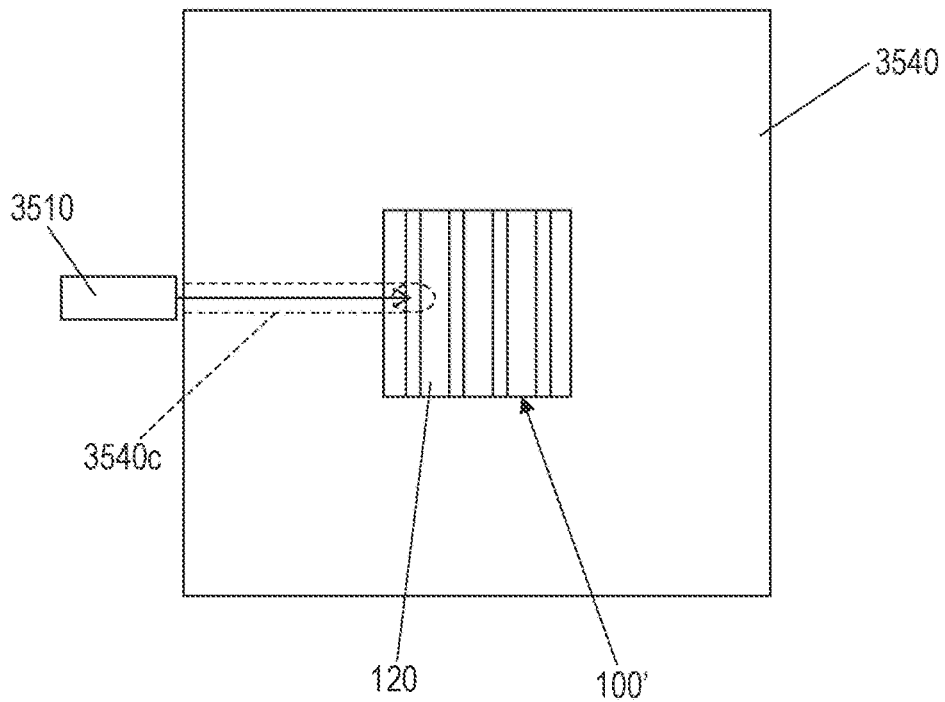

FIG. 71A

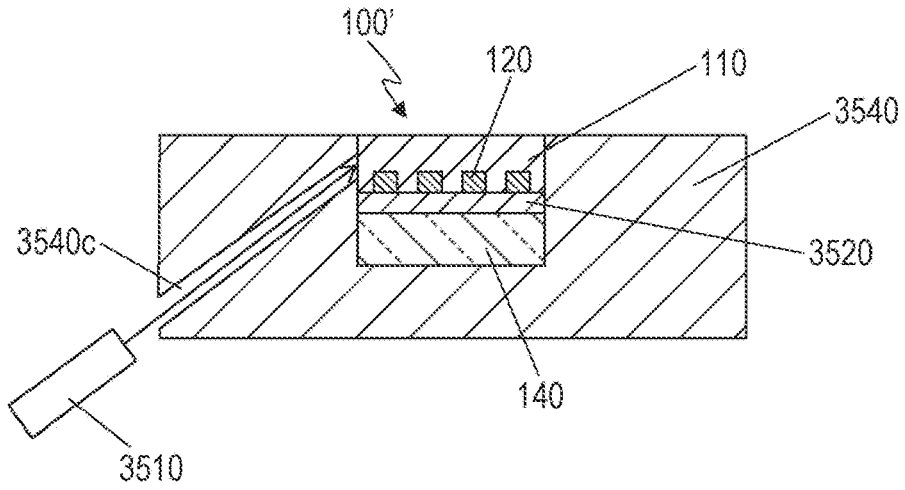

FIG. 71B

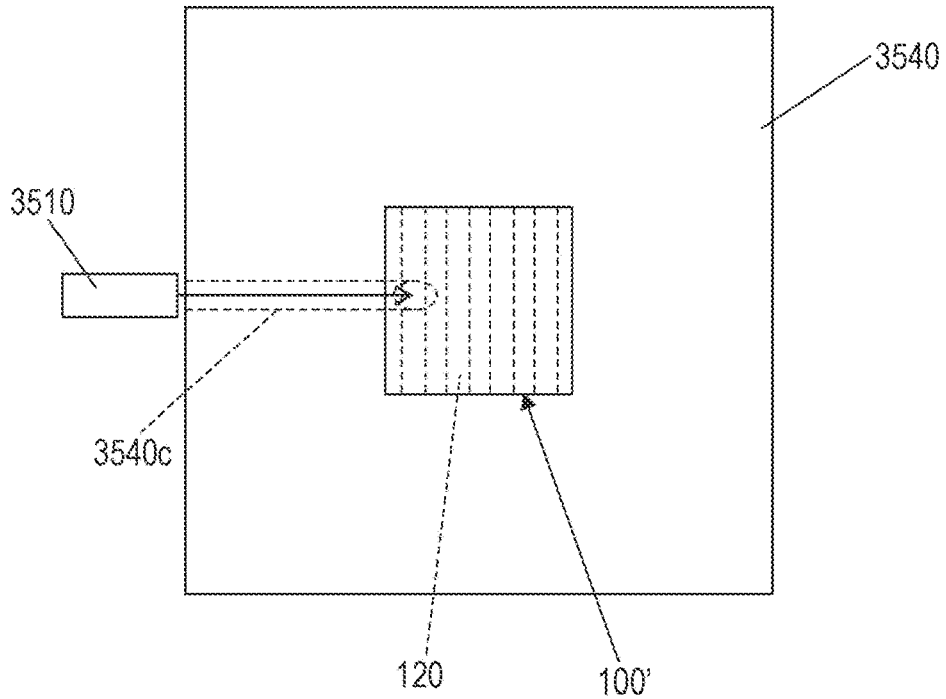

FIG. 72A

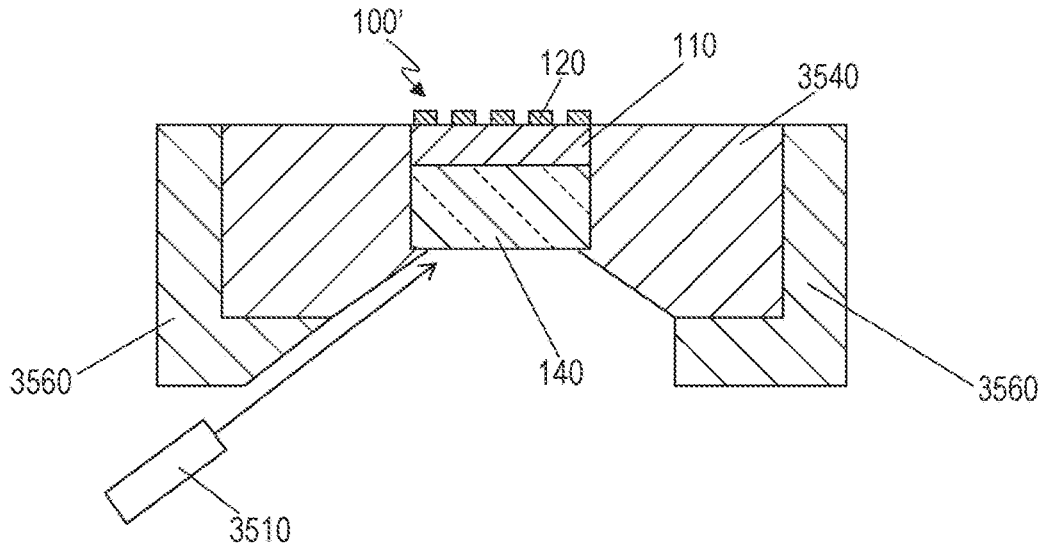

FIG. 72B

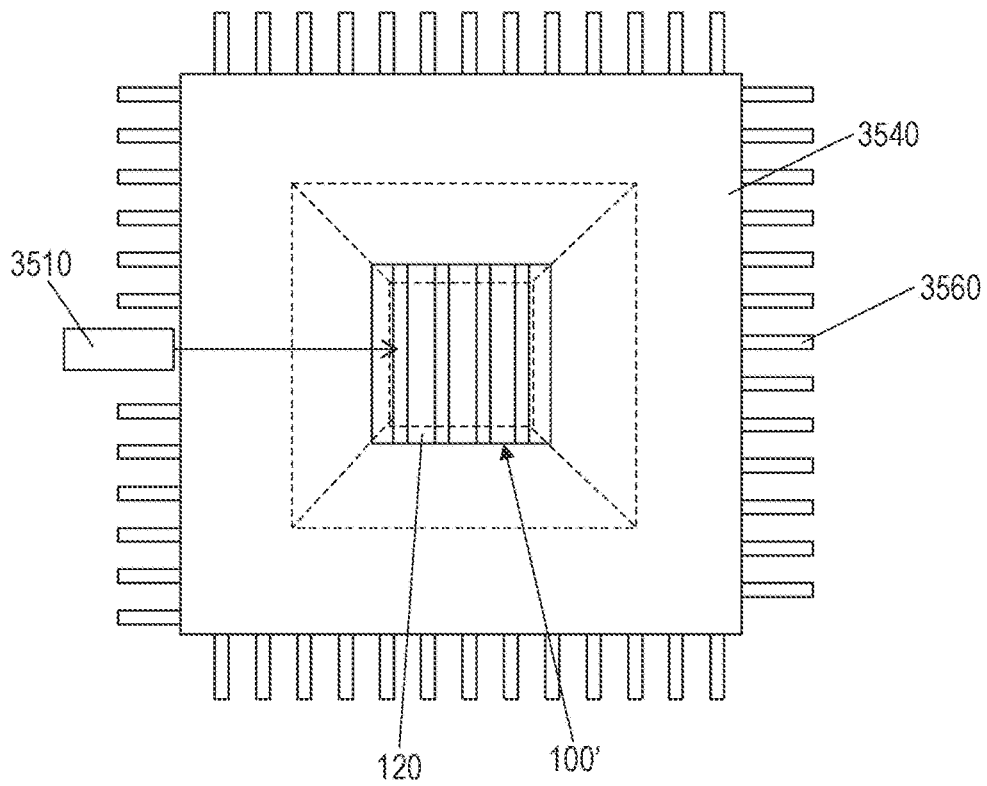

FIG. 73A

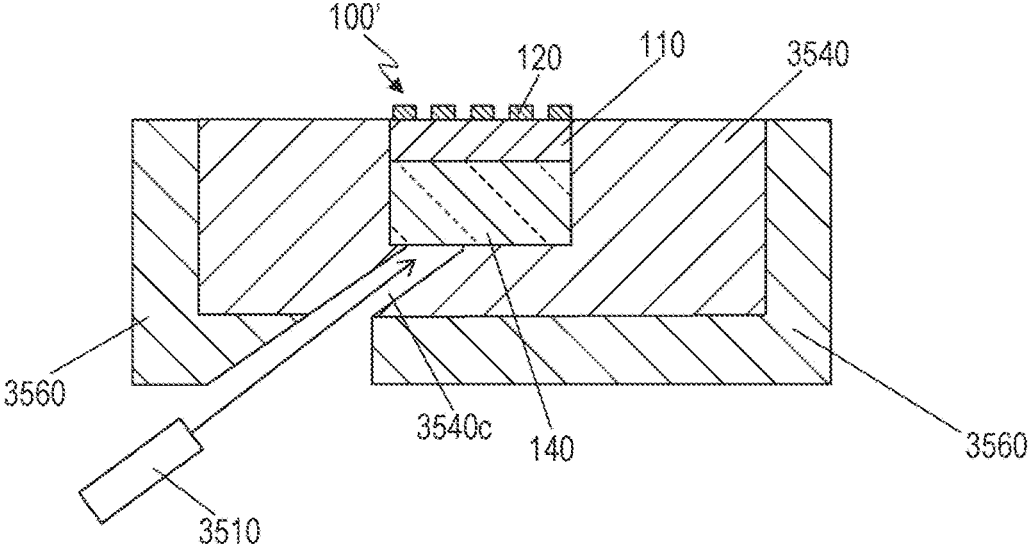

FIG. 73B

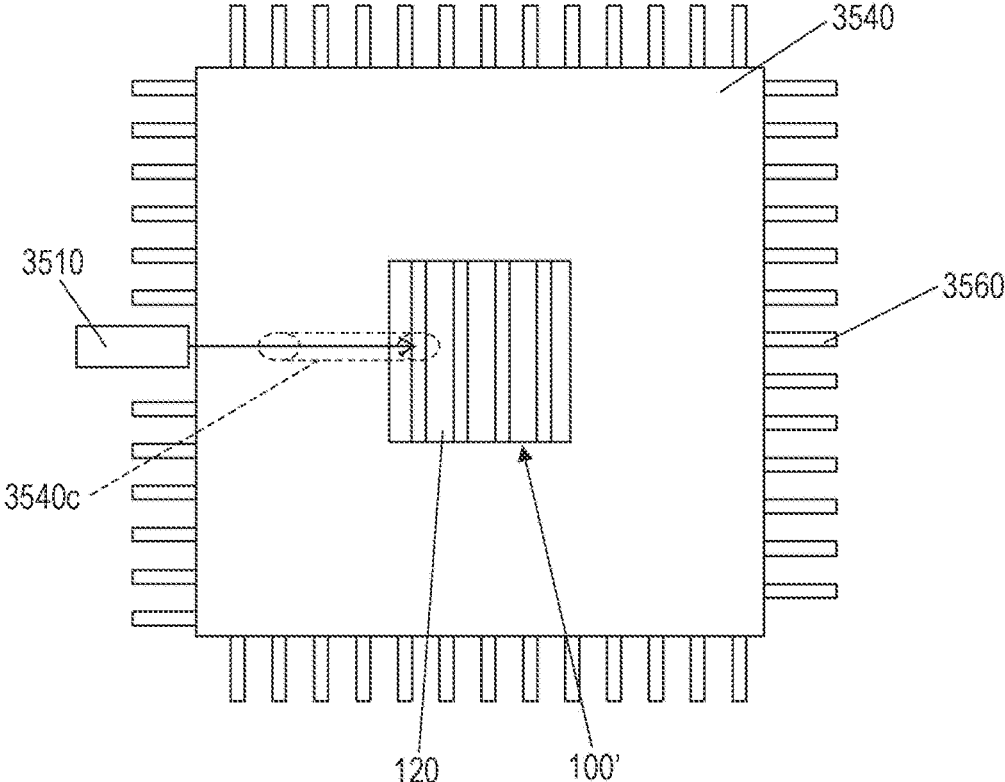

FIG. 74A

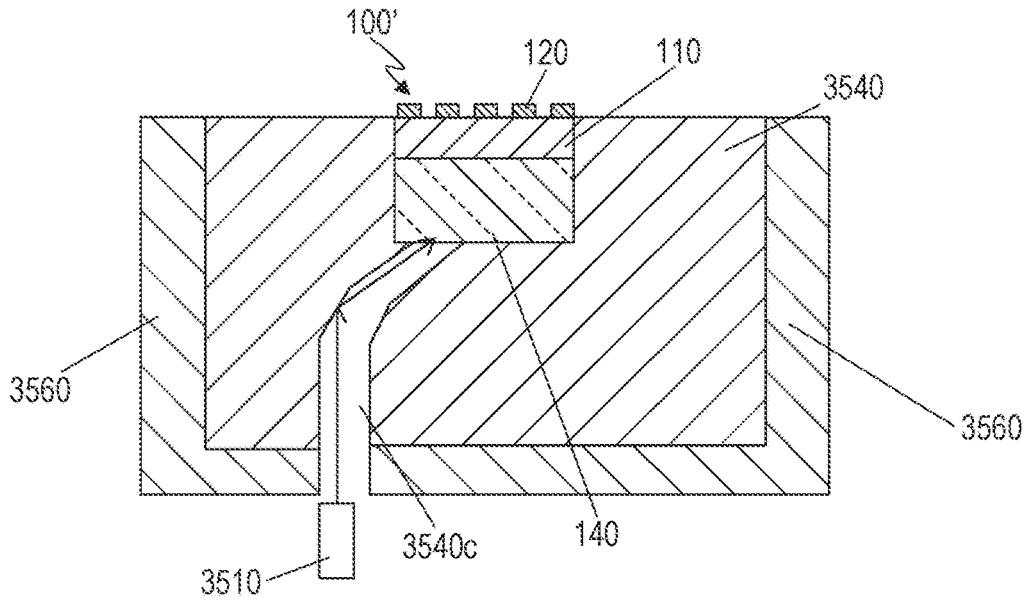

FIG. 74B

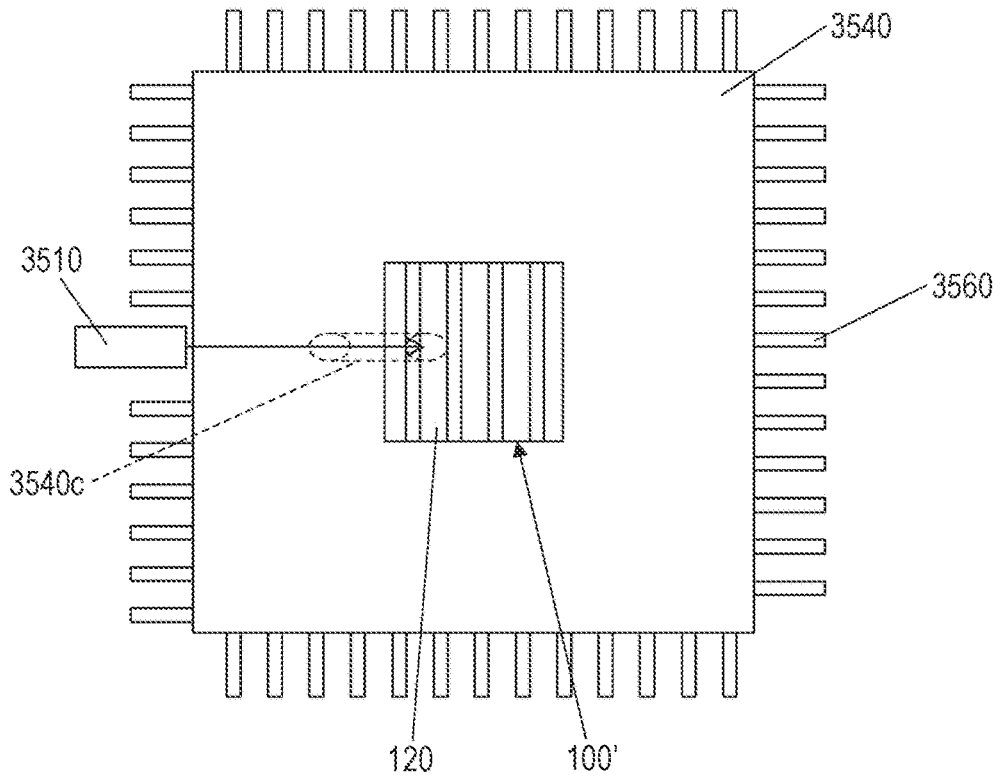

FIG. 75A

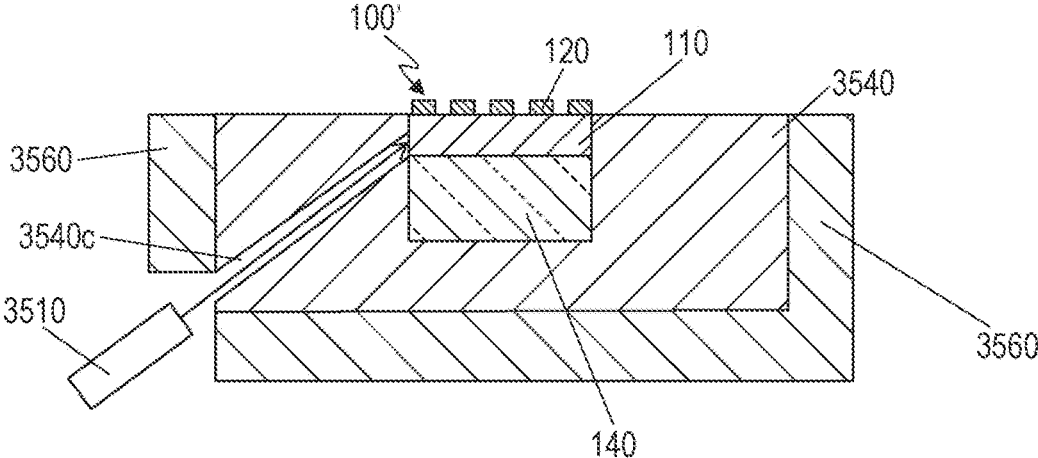

FIG. 75B

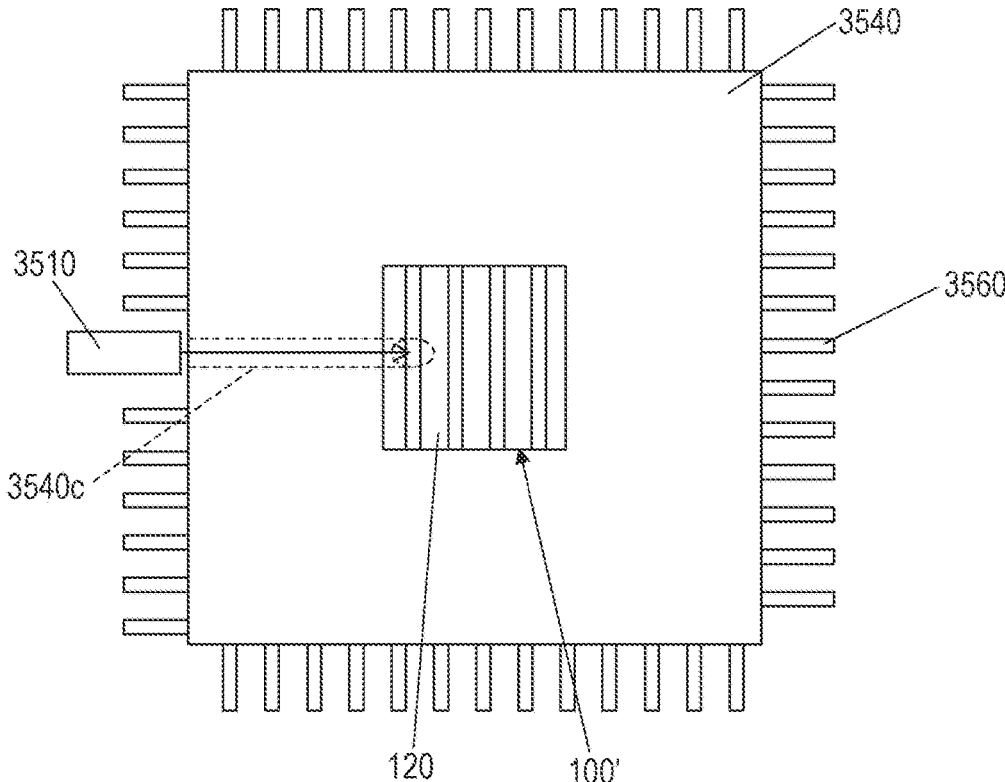

FIG. 76A

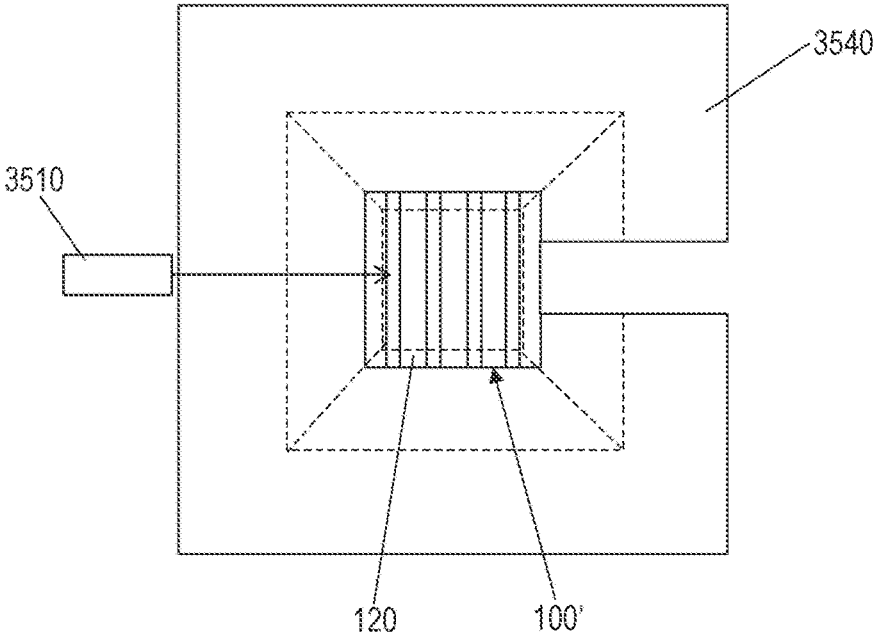

FIG. 76B

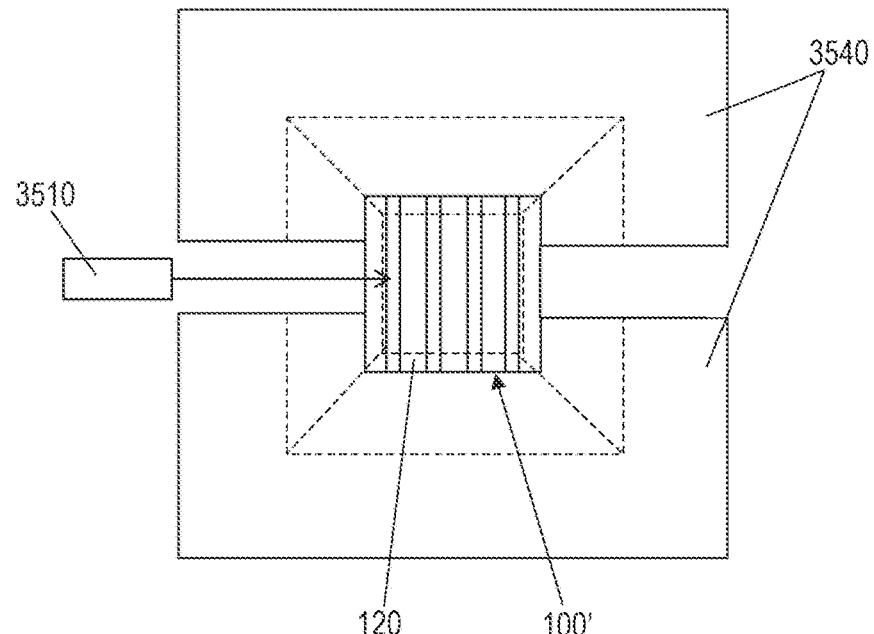

FIG. 77

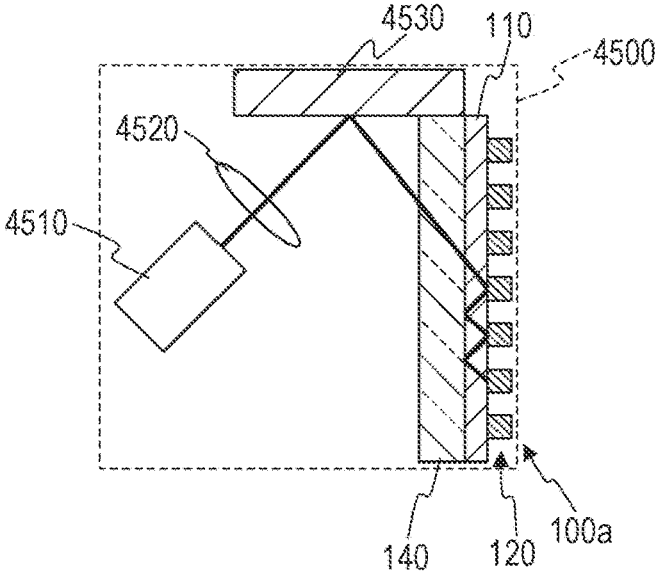

FIG. 78

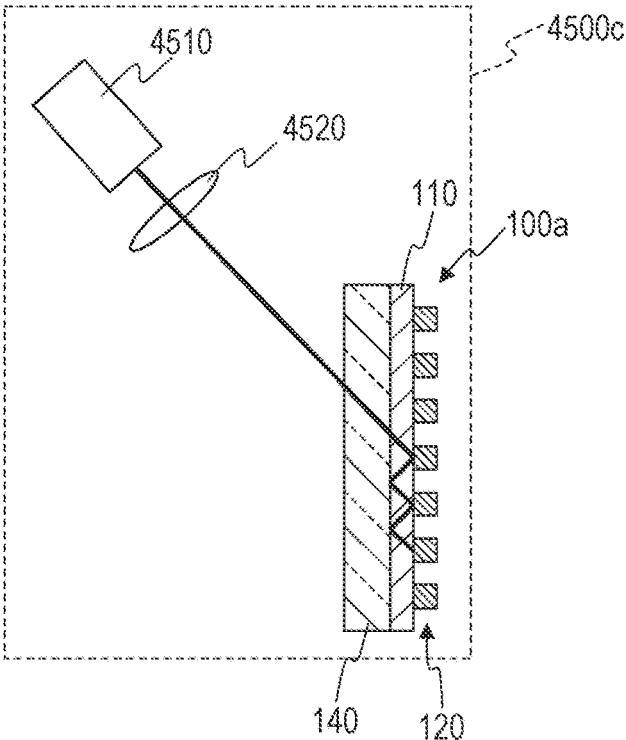

FIG. 79

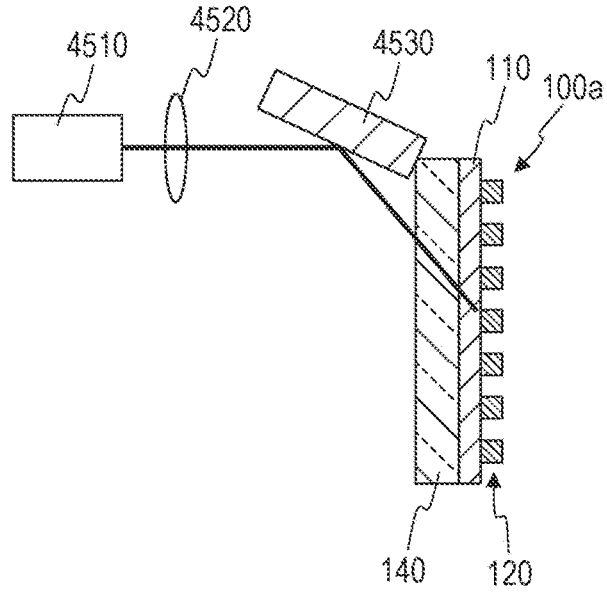

FIG. 80

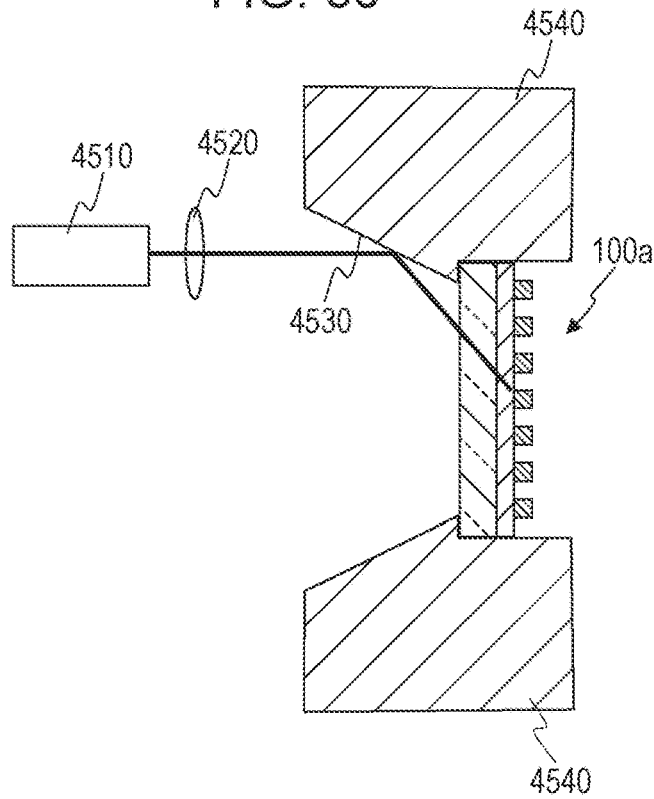

FIG. 81

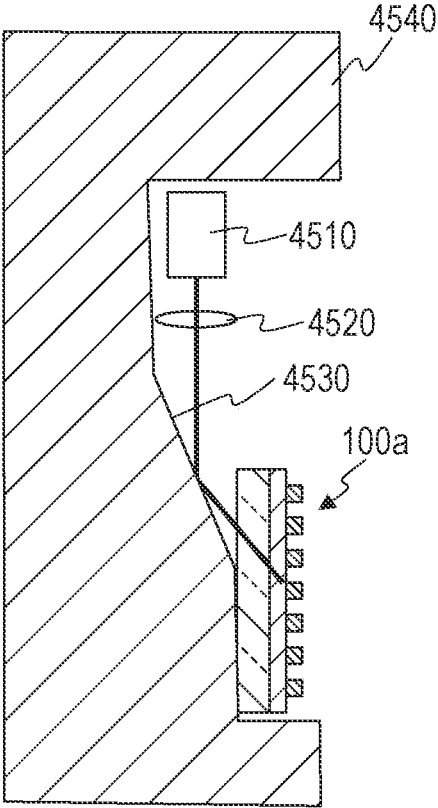

FIG. 82

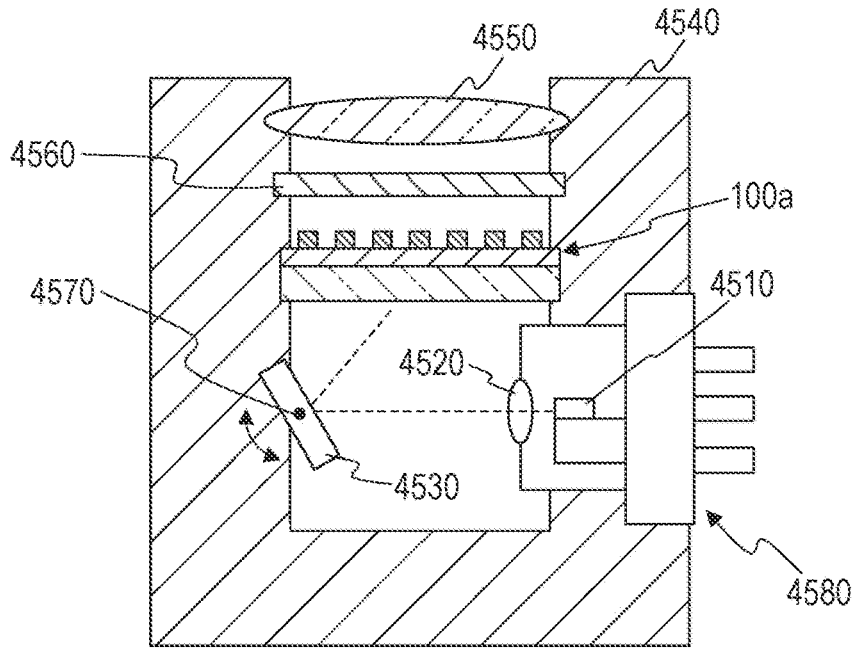

FIG. 83

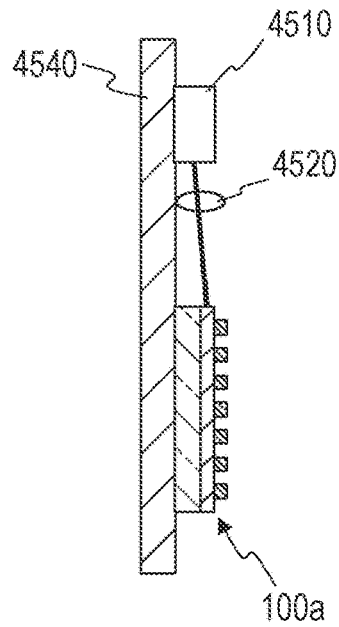

FIG. 84A

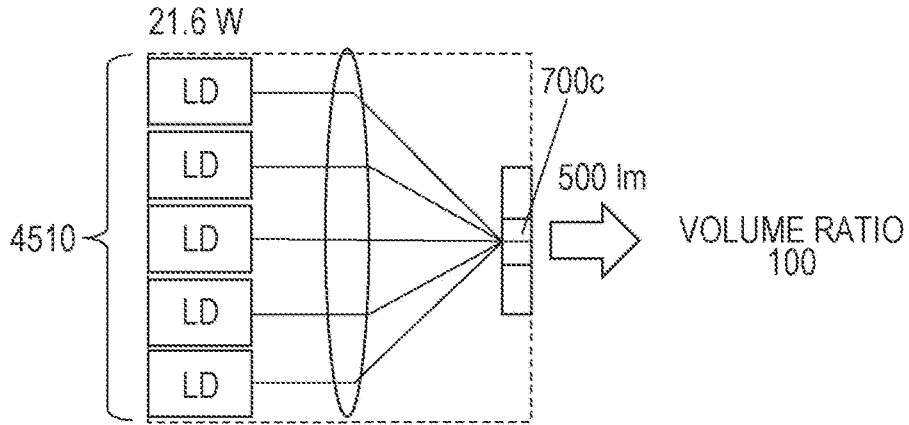

FIG. 84B

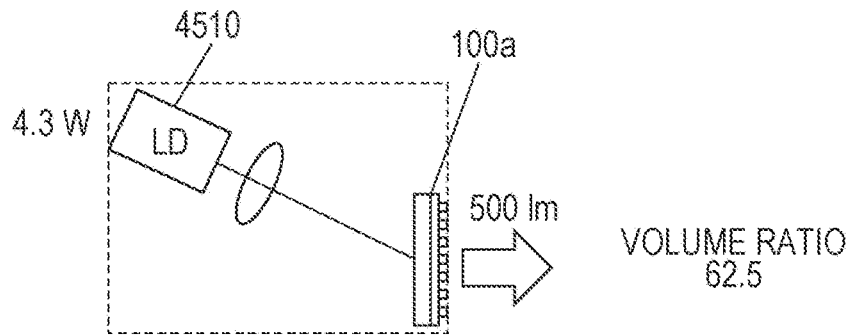

FIG. 84C

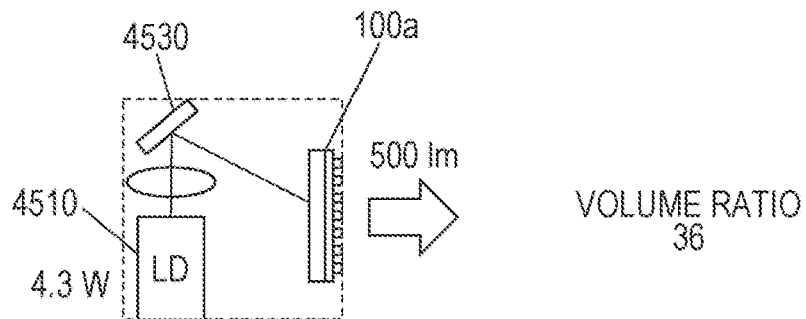

FIG. 85

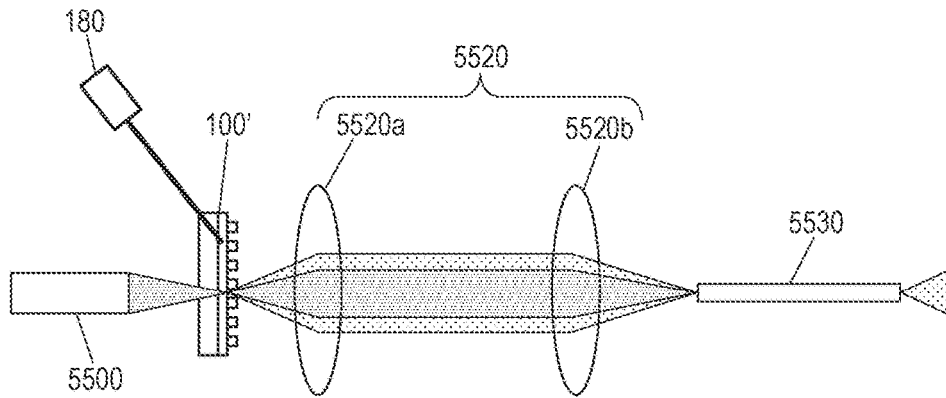

FIG. 86

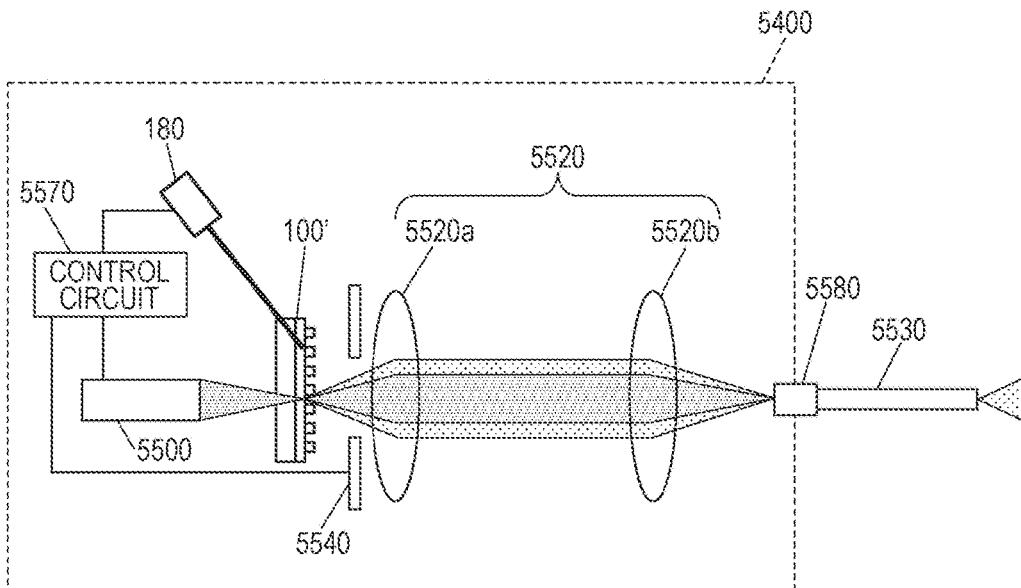

FIG. 87

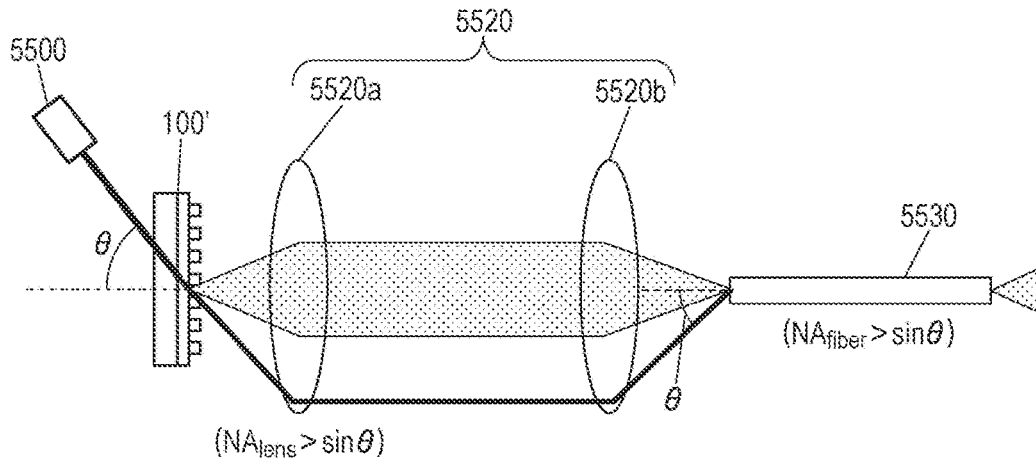

FIG. 88

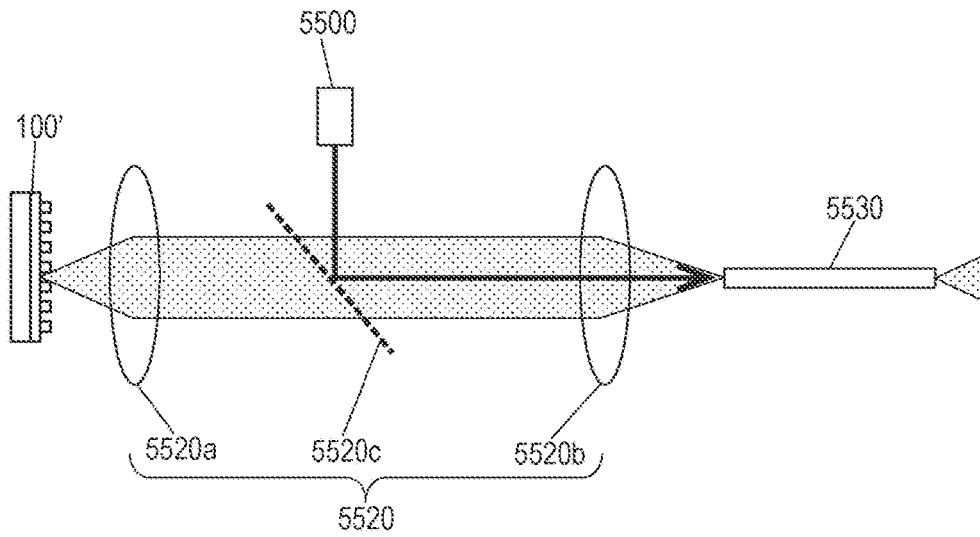

FIG. 89

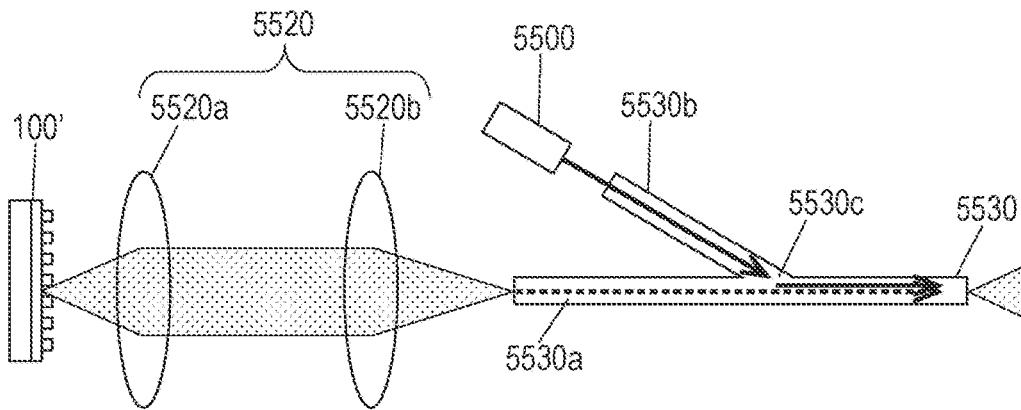

FIG. 90

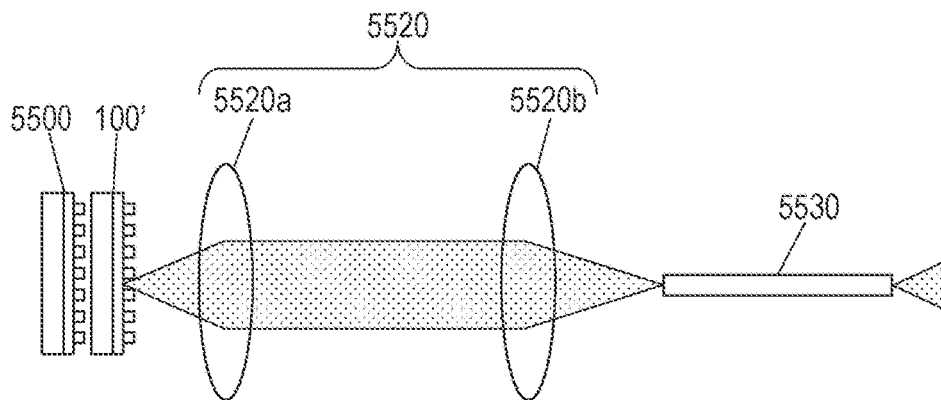

FIG. 91

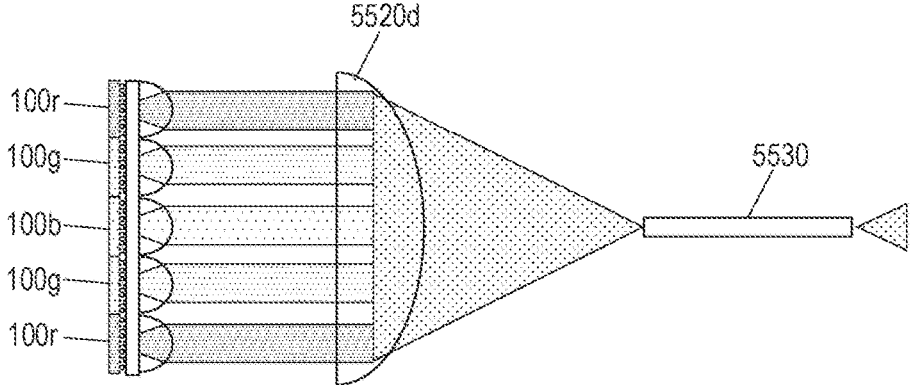

FIG. 92

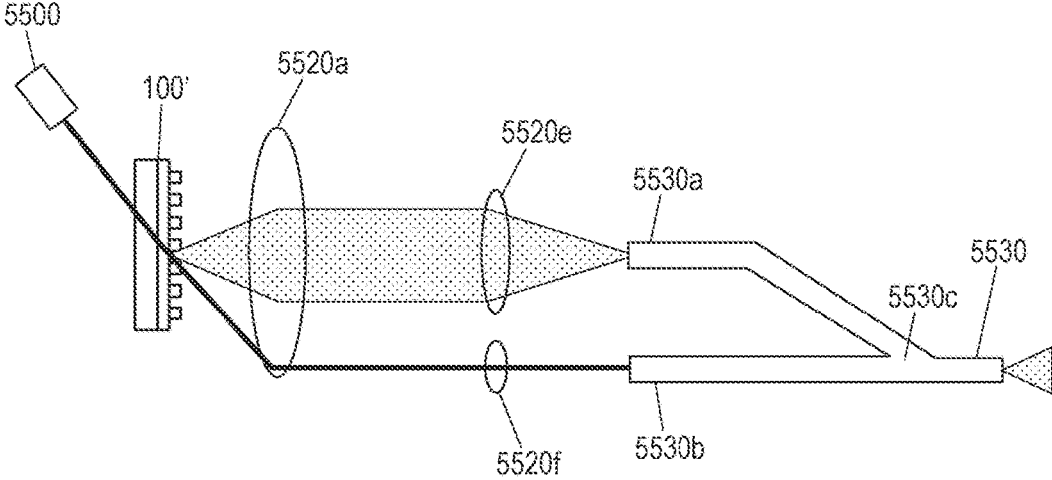

FIG. 93

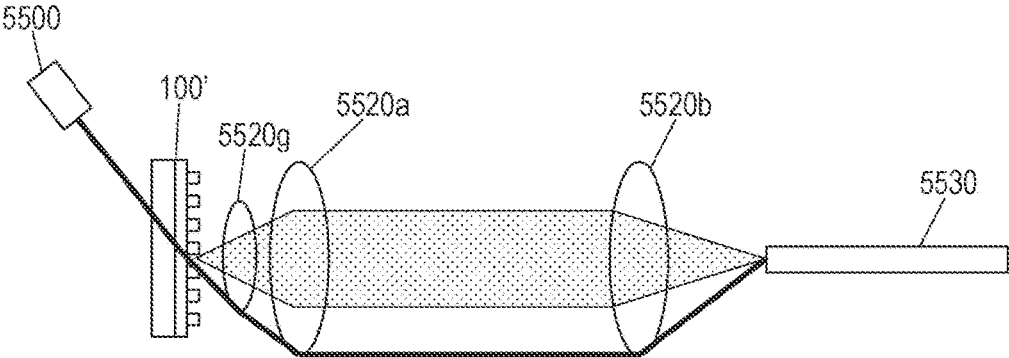

FIG. 94

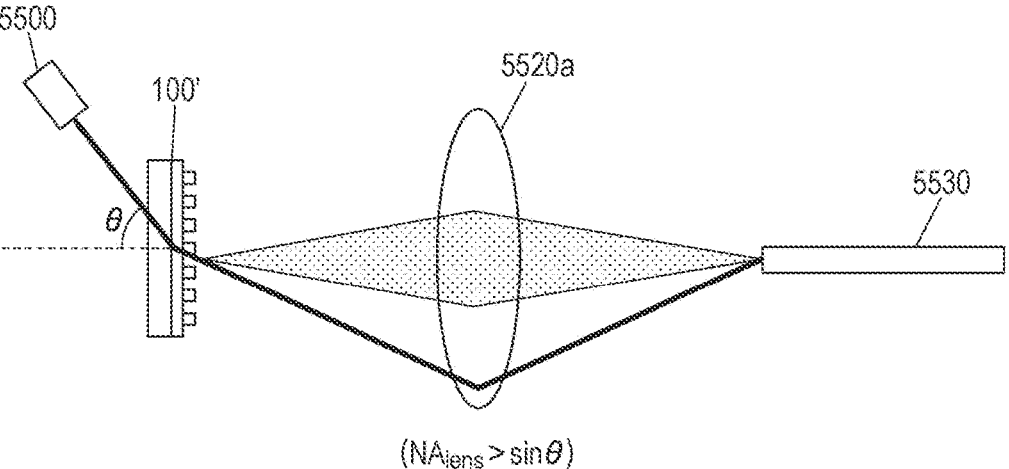

FIG. 95

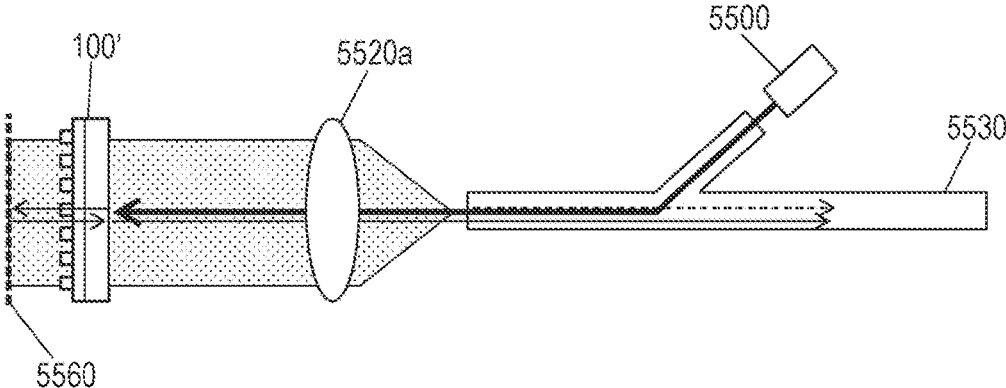

FIG. 96

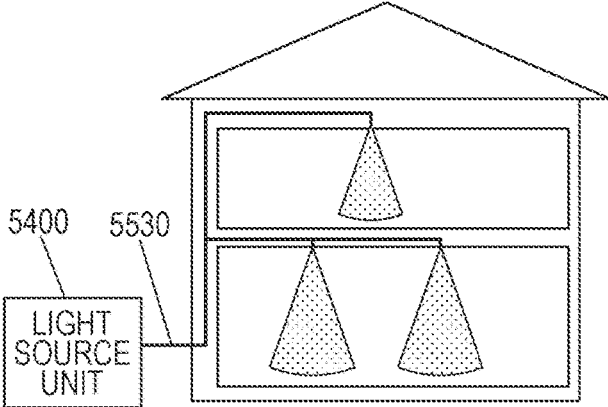

FIG. 97

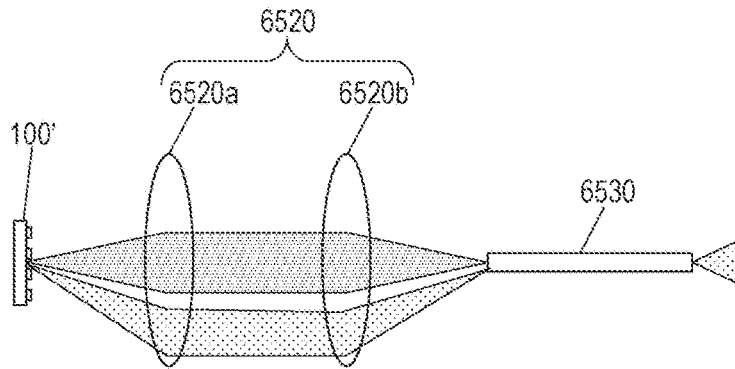

FIG. 98

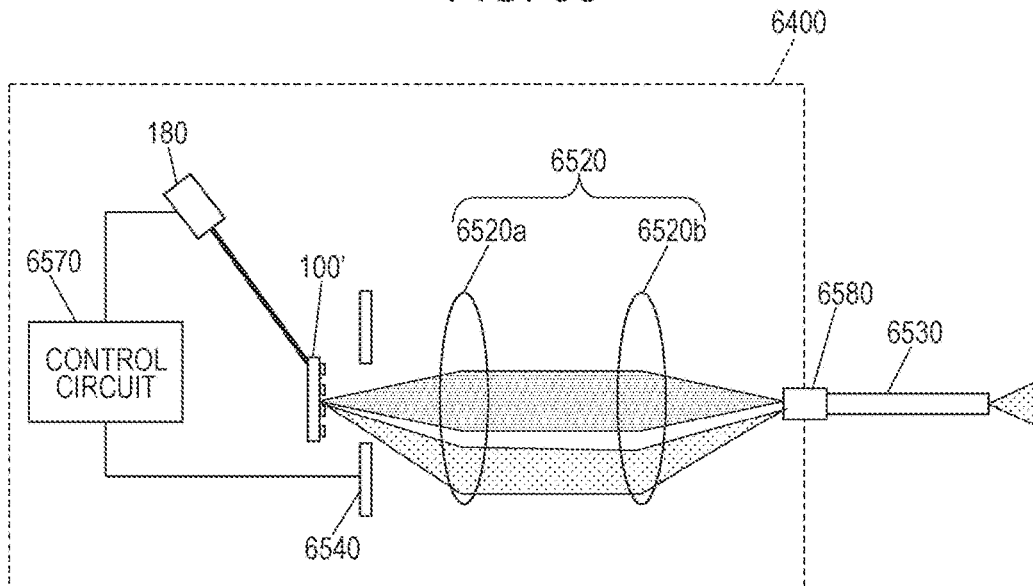

FIG. 99

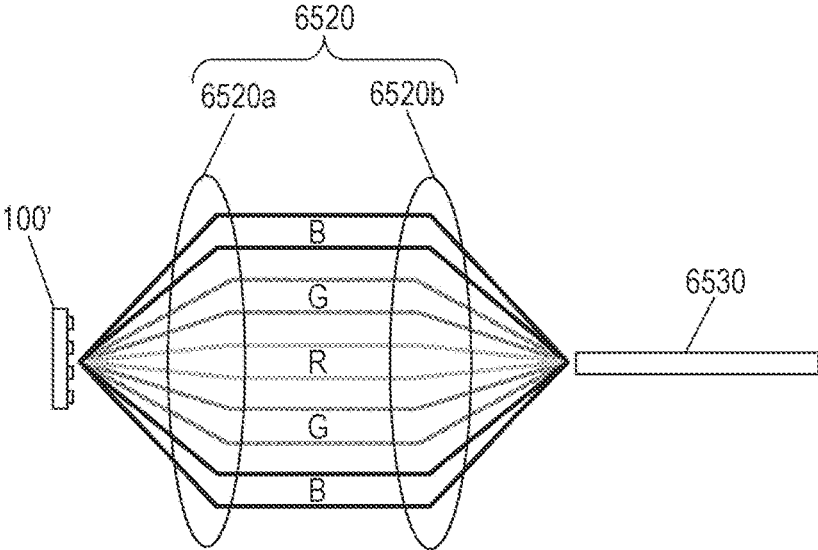

FIG. 100

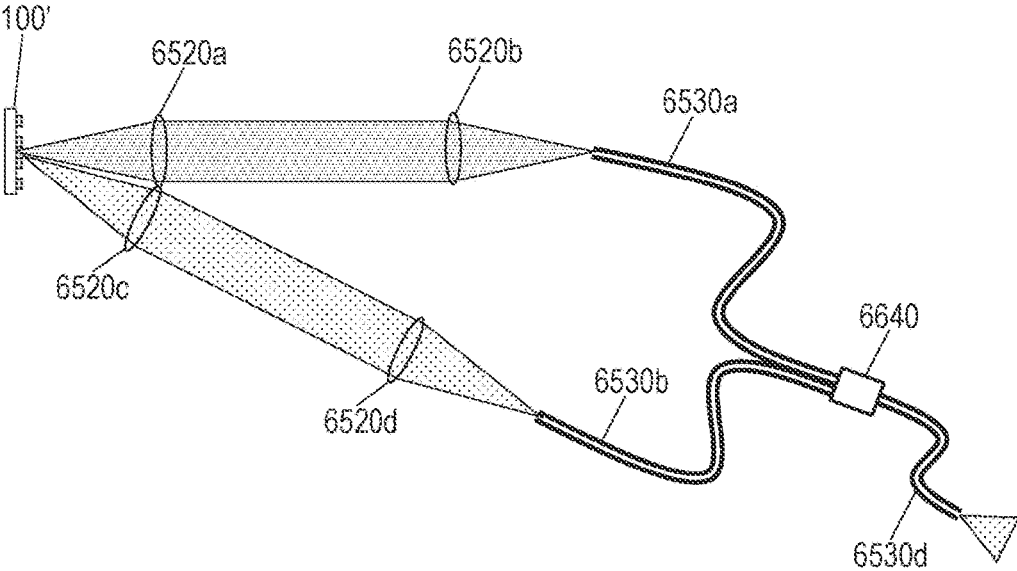

FIG. 101

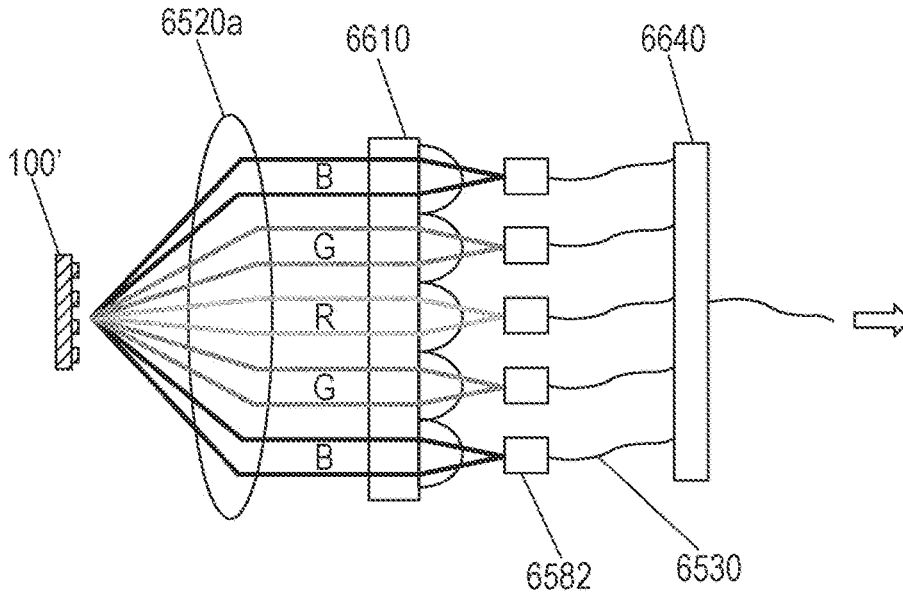

FIG. 102

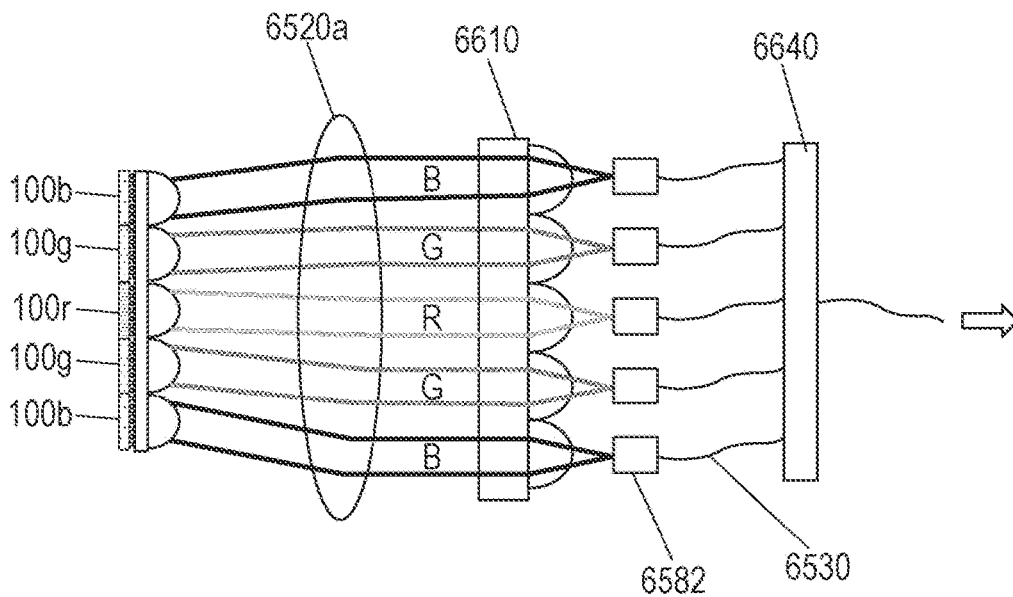

FIG. 103

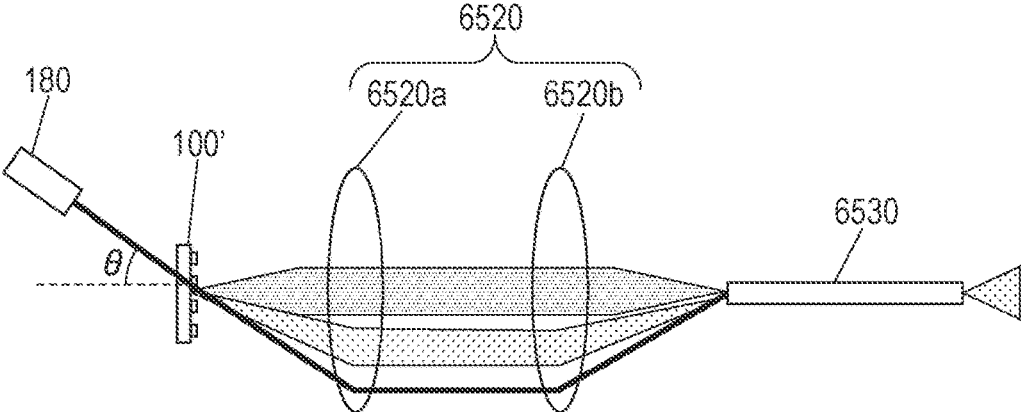

FIG. 104

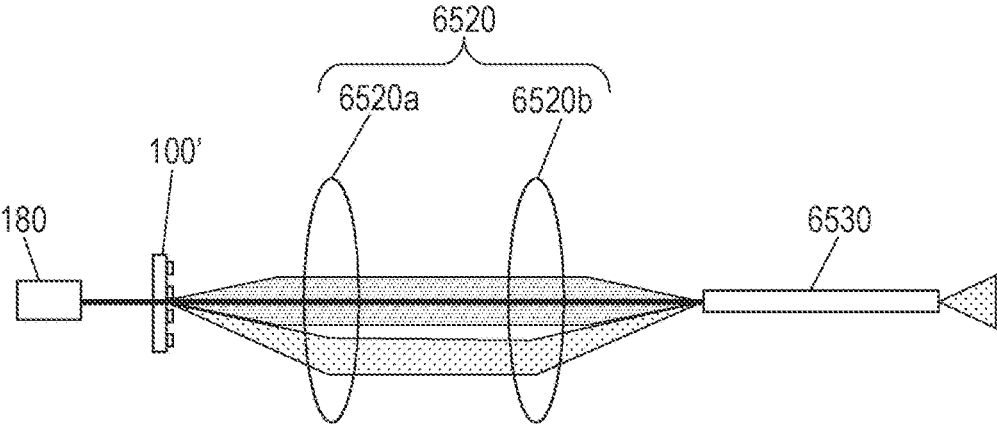

FIG. 105

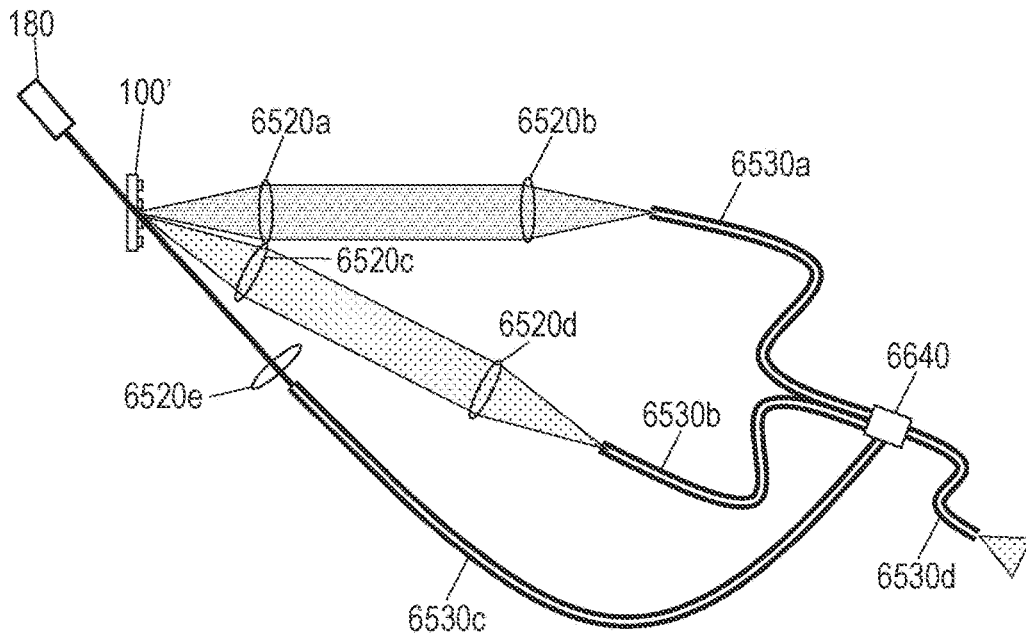

FIG. 106

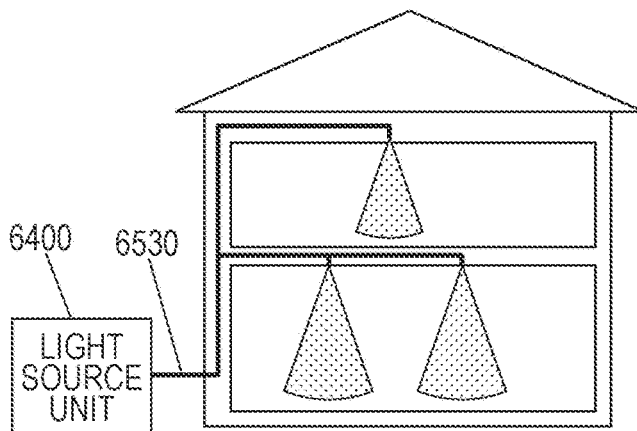
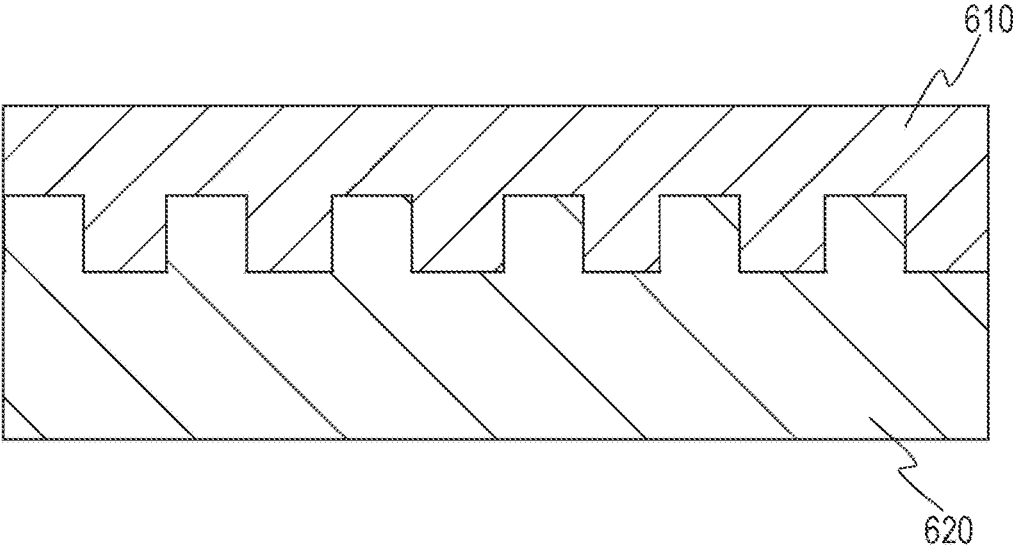

FIG. 107



LIGHT-EMITTING APPARATUS

Matter enclosed in heavy brackets [] appears in the original patent but forms no part of this reissue specification; matter printed in italics indicates the additions made by reissue; a claim printed with strikethrough indicates that the claim was canceled, disclaimed, or held invalid by a prior post-patent action or proceeding.

CROSS REFERENCE TO RELATED APPLICATIONS

This application is a reissue application of U.S. Pat. No. 10,359,155 issued on Jul. 23, 2019 issued from U.S. patent application Ser. No. 15/206,273 filed on Jul. 10, 2016, which claims priority to Japanese Patent Application No. 2015-163681 filed on Aug. 21, 2015, Japanese Patent Application No. 2015-162405 filed on Aug. 20, 2015, Japanese Patent Application No. 2015-163680 filed on Aug. 21, 2015, Japanese Patent Application No. 2015-163042 filed on Aug. 20, 2015, Japanese Patent Application No. 2015-162404 filed on Aug. 20, 2015, Japanese Patent Application No. 2015-162403 filed on Aug. 20, 2015 and Japanese Patent Application No. 2016-070837 filed on Mar. 31, 2016.

BACKGROUND

1. Technical Field

The present disclosure relates to a light-emitting apparatus and more particularly to a light-emitting apparatus having a photoluminescent layer.

2. Description of the Related Art

Optical devices, such as lighting fixtures, displays and projectors, which output light in the necessary direction, are required for many applications. Photoluminescent materials, such as those used for fluorescent lamps and white light-emitting diodes (LEDs), emit light in all directions. Thus, those materials are used in combination with optical elements such as reflectors and lenses to emit light only in a particular direction. For example, Japanese Unexamined Patent Application Publication No. 2010-231941 discloses a lighting system including a light distributor and an auxiliary reflector to provide sufficient directionality.

An optical component, such as a reflector or lens, in an optical device increases the size of the optical device. Thus, miniaturization of such an optical component can advantageously decrease the size of the optical device.

SUMMARY

In one general aspect, the techniques disclosed here feature a light-emitting apparatus that includes an excitation light source that emits first light; a light-emitting device on an optical path of the first light, the light-emitting device emitting second light having a wavelength λ_a in air; and a first converging lens on an optical path of the second light. The light-emitting device comprises: a photoluminescent layer that emits the second light by being excited by the first light; and a light-transmissive layer on the photoluminescent layer. At least one of the photoluminescent layer and the light-transmissive layer has a surface structure comprising projections or recesses arranged perpendicular to a thickness direction of the photoluminescent layer. At least one of the

photoluminescent layer and the light-transmissive layer has a light emitting surface perpendicular to the thickness direction, the second light emitted from the light emitting surface. The surface structure limits the directional angle of the second light emitted from the light emitting surface.

General or specific embodiments may be implemented as a device, an apparatus, a system, a method, or any selective combination thereof.

Additional benefits and advantages of the disclosed embodiments will become apparent from the specification and drawings. The benefits and/or advantages may be individually obtained by the various embodiments and features of the specification and drawings, which need not all be provided in order to obtain one or more of such benefits and/or advantages.

BRIEF DESCRIPTION OF THE DRAWINGS

FIG. 1A is a perspective view of the structure of a light-emitting device according to an embodiment;

FIG. 1B is a fragmentary cross-sectional view of the light-emitting device illustrated in FIG. 1A;

FIG. 1C is a perspective view of the structure of a light-emitting device according to another embodiment;

FIG. 1D is a fragmentary cross-sectional view of the light-emitting device illustrated in FIG. 1C;

FIG. 2 is a graph showing the calculation results of the enhancement of light emitted in the front direction with varying emission wavelengths and varying heights of a periodic structure;

FIG. 3 is a graph illustrating the conditions for $m=1$ and $m=3$ in the formula (10);

FIG. 4 is a graph showing the calculation results of the enhancement of light emitted in the front direction with varying emission wavelengths and varying thicknesses t of a photoluminescent layer;

FIG. 5A is a graph showing the calculation results of the electric field distribution of a mode to guide light in the x direction for a thickness t of 238 nm;

FIG. 5B is a graph showing the calculation results of the electric field distribution of a mode to guide light in the x direction for a thickness t of 539 nm;

FIG. 5C is a graph showing the calculation results of the electric field distribution of a mode to guide light in the x direction for a thickness t of 300 nm;

FIG. 6 is a graph showing the calculation results of the enhancement of light under the same conditions as in FIG. 2 except that the polarization of light is in the TE mode, which has an electric field component perpendicular to the y direction;

FIG. 7A is a plan view of a two-dimensional periodic structure;

FIG. 7B is a graph showing the results of calculations performed as in FIG. 2 for the two-dimensional periodic structure;

FIG. 8 is a graph showing the calculation results of the enhancement of light emitted in the front direction with varying emission wavelengths and varying refractive indices of the periodic structure;

FIG. 9 is a graph showing the results obtained under the same conditions as in FIG. 8 except that the photoluminescent layer has a thickness of 1,000 nm;

FIG. 10 is a graph showing the calculation results of the enhancement of light emitted in the front direction with varying emission wavelengths and varying heights of the periodic structure;

FIG. 11 is a graph showing the results of calculations performed under the same conditions as in FIG. 10 except that the periodic structure has a refractive index n_p of 2.0;

FIG. 12 is a graph showing the results of calculations performed under the same conditions as in FIG. 9 except that the polarization of the light is in the TE mode, which has an electric field component perpendicular to the y direction;

FIG. 13 is a graph showing the results of calculations performed under the same conditions as in FIG. 9 except that the photoluminescent layer has a refractive index n_{wav} of 1.5;

FIG. 14 is a graph showing the results of calculations performed under the same conditions as in FIG. 2 except that the photoluminescent layer and the periodic structure are disposed on a transparent substrate having a refractive index of 1.5;

FIG. 15 is a graph illustrating the condition represented by the formula (15);

FIG. 16 is a schematic view of a light-emitting apparatus including a light-emitting device illustrated in FIGS. 1A and 1B and a light source that emits excitation light toward a photoluminescent layer;

FIG. 17A is a schematic view of a one-dimensional periodic structure having a period p_x in the x direction;

FIG. 17B is a schematic view of a two-dimensional periodic structure having a period p_x in the x direction and a period p_y in the y direction;

FIG. 17C is a graph showing the wavelength dependence of light absorptivity in the structure illustrated in FIG. 17A;

FIG. 17D is a graph showing the wavelength dependence of light absorptivity in the structure illustrated in FIG. 17B;

FIG. 18A is a schematic view of a two-dimensional periodic structure;

FIG. 18B is a schematic view of another two-dimensional periodic structure;

FIG. 19A is a schematic view of a modified example in which a periodic structure is formed on a transparent substrate;

FIG. 19B is a schematic view of another modified example in which a periodic structure is formed on a transparent substrate;

FIG. 19C is a graph showing the calculation results of the enhancement of light emitted from the structure illustrated in FIG. 19A in the front direction with varying emission wavelengths and varying periods of the periodic structure;

FIG. 20 is a schematic view of a mixture of light-emitting devices in powder form;

FIG. 21 is a plan view of a two-dimensional array of periodic structures having different periods on a photoluminescent layer;

FIG. 22 is a schematic view of a light-emitting device including photoluminescent layers each having a textured surface;

FIG. 23 is a cross-sectional view of a structure including a protective layer between a photoluminescent layer and a surface structure;

FIG. 24 is a cross-sectional view of a structure including a surface structure formed by processing only a portion of a photoluminescent layer;

FIG. 25 is a cross-sectional transmission electron microscopy (TEM) image of a photoluminescent layer formed on a glass substrate having a periodic structure;

FIG. 26 is a graph showing the measurement results of the spectrum of light emitted from a sample light-emitting device in the front direction;

FIG. 27A is a schematic view of a light-emitting device that can emit linearly polarized light in the TM mode, rotated

about an axis parallel to the line direction of the one-dimensional periodic structure;

FIG. 27B is a graph showing the measurement results of the angular dependence of light emitted from the sample light-emitting device rotated as illustrated in FIG. 27A;

FIG. 27C is a graph showing the calculation results of the angular dependence of light emitted from the sample light-emitting device rotated as illustrated in FIG. 27A;

FIG. 27D is a schematic view of a light-emitting device that can emit linearly polarized light in the TE mode, rotated about an axis parallel to the line direction of the one-dimensional periodic structure;

FIG. 27E is a graph showing the measurement results of the angular dependence of light emitted from the sample light-emitting device rotated as illustrated in FIG. 27D;

FIG. 27F is a graph showing the calculation results of the angular dependence of light emitted from the sample light-emitting device rotated as illustrated in FIG. 27D;

FIG. 28A is a schematic view of a light-emitting device that can emit linearly polarized light in the TE mode, rotated about an axis perpendicular to the line direction of the one-dimensional periodic structure;

FIG. 28B is a graph showing the measurement results of the angular dependence of light emitted from the sample light-emitting device rotated as illustrated in FIG. 28A;

FIG. 28C is a graph showing the calculation results of the angular dependence of light emitted from the sample light-emitting device rotated as illustrated in FIG. 28A;

FIG. 28D is a schematic view of a light-emitting device that can emit linearly polarized light in the TM mode, rotated about an axis perpendicular to the line direction of the one-dimensional periodic structure;

FIG. 28E is a graph showing the measurement results of the angular dependence of light emitted from the sample light-emitting device rotated as illustrated in FIG. 28D;

FIG. 28F is a graph showing the calculation results of the angular dependence of light emitted from the sample light-emitting device rotated as illustrated in FIG. 28D;

FIG. 29 is a graph showing the measurement results of the angular dependence of light (wavelength: 610 nm) emitted from a sample light-emitting device;

FIG. 30 is a schematic perspective view of a slab waveguide;

FIG. 31 is a schematic view illustrating the relationship between the wavelength and emission direction of light under the emission enhancement effect in a light-emitting device having a surface structure on a photoluminescent layer;

FIG. 32A is a schematic plan view of an example structure of an array of periodic structures having different wavelengths at which the light enhancement effect is produced;

FIG. 32B is a schematic plan view of an example structure that includes an array of one-dimensional periodic structures having projections extending in different directions;

FIG. 32C is a schematic plan view of an example structure that includes an array of two-dimensional periodic structures;

FIG. 33 is a schematic cross-sectional view of a light-emitting device including microlenses;

FIG. 34A is a schematic cross-sectional view of a light-emitting device that includes photoluminescent layers having different emission wavelengths;

FIG. 34B is a schematic cross-sectional view of another light-emitting device that includes photoluminescent layers having different emission wavelengths;

5

FIG. 35 is a schematic view of an exemplary structure of a light-emitting apparatus according to an embodiment of the present disclosure;

FIG. 36 is a schematic view illustrating coupling efficiency between a light-emitting device and a converging lens in a light-emitting apparatus according to an embodiment of the present disclosure;

FIG. 37 is a schematic view illustrating coupling efficiency between a phosphor and a converging lens in a light-emitting apparatus according to a comparative example;

FIG. 38 is a schematic view of another modified example of a light-emitting apparatus according to an embodiment of the present disclosure;

FIG. 39 is a schematic view of still another modified example of a light-emitting apparatus according to an embodiment of the present disclosure;

FIG. 40 is a schematic view of still another modified example of a light-emitting apparatus according to an embodiment of the present disclosure;

FIG. 41 is a schematic view of still another modified example of a light-emitting apparatus according to an embodiment of the present disclosure;

FIG. 42 is an outside drawing of a projector according to an embodiment of the present disclosure;

FIG. 43 is a schematic view of an optical system of the projector illustrated in FIG. 42;

FIG. 44 is a block diagram of the projector illustrated in FIG. 42;

FIG. 45A is a schematic view of an image formed using light reflected from a micro electro mechanical system (MEMS) mirror;

FIG. 45B is a schematic view of another example of an optical system for changing the wavelength of light emitted from an optical fiber;

FIG. 46 is a schematic view of another optical system of the projector;

FIG. 47 is a block diagram of the optical system illustrated in FIG. 46;

FIG. 48 is a schematic view illustrating optical coupling between a light source and an optical fiber;

FIG. 49 is a schematic graph of the relationship between the luminous area S of a light source and the amount A of light introduced into an optical fiber;

FIG. 50 is an outside drawing of a projector according to a comparative example including a lighting unit that houses all the optical components of an image forming optical system;

FIG. 51 is a schematic view of image forming components in the lighting unit of the projector illustrated in FIG. 50;

FIG. 52 is a schematic view of still another optical system of the projector;

FIG. 53 is a schematic view of still another optical system of the projector;

FIG. 54A is a schematic cross-sectional view of a light-emitting apparatus including a light-emitting device and a support for supporting the light-emitting device;

FIG. 54B is a plan view of the light-emitting apparatus illustrated in FIG. 54A, viewed from above;

FIG. 54C is a schematic view of a light-emitting apparatus including a light introducing structure for efficiently guiding excitation light into a photoluminescent layer;

FIG. 55A is a schematic cross-sectional view of another light-emitting apparatus including a light-emitting device and a support for supporting the light-emitting device;

6

FIG. 55B is a plan view of the light-emitting apparatus illustrated in FIG. 55A, viewed from above;

FIG. 56A is a schematic cross-sectional view of still another light-emitting apparatus including a light-emitting device and a support for supporting the light-emitting device;

FIG. 56B is a plan view of the light-emitting apparatus illustrated in FIG. 56A, viewed from above;

FIG. 57A is a schematic cross-sectional view of still another light-emitting apparatus including a light-emitting device and a support for supporting the light-emitting device;

FIG. 57B is a plan view of the light-emitting apparatus illustrated in FIG. 57A, viewed from above;

FIG. 58A is a schematic cross-sectional view of still another light-emitting apparatus including a light-emitting device and a support for supporting the light-emitting device;

FIG. 58B is a plan view of the light-emitting apparatus illustrated in FIG. 58A, viewed from above;

FIG. 59A is a schematic cross-sectional view of still another light-emitting apparatus including a light-emitting device and a support for supporting the light-emitting device;

FIG. 59B is a plan view of the light-emitting apparatus illustrated in FIG. 59A, viewed from above;

FIG. 60A is a schematic cross-sectional view of still another light-emitting apparatus including a light-emitting device and a support for supporting the light-emitting device;

FIG. 60B is a plan view of the light-emitting apparatus illustrated in FIG. 60A, viewed from above;

FIG. 61A is a schematic cross-sectional view of still another light-emitting apparatus including a light-emitting device and a support for supporting the light-emitting device;

FIG. 61B is a plan view of the light-emitting apparatus illustrated in FIG. 61A, viewed from above;

FIG. 62A is a schematic cross-sectional view of still another light-emitting apparatus including a light-emitting device and a support for supporting the light-emitting device;

FIG. 62B is a plan view of the light-emitting apparatus illustrated in FIG. 62A, viewed from above;

FIG. 63A is a schematic cross-sectional view of still another light-emitting apparatus including a light-emitting device and a support for supporting the light-emitting device;

FIG. 63B is a plan view of the light-emitting apparatus illustrated in FIG. 63A, viewed from above;

FIG. 64A is a schematic cross-sectional view of still another light-emitting apparatus including a light-emitting device and a support for supporting the light-emitting device;

FIG. 64B is a plan view of the light-emitting apparatus illustrated in FIG. 64A, viewed from above;

FIG. 65A is a schematic cross-sectional view of still another light-emitting apparatus including a light-emitting device and a support for supporting the light-emitting device;

FIG. 65B is a plan view of the light-emitting apparatus illustrated in FIG. 65A, viewed from above;

FIG. 66A is a schematic cross-sectional view of still another light-emitting apparatus including a light-emitting device and a support for supporting the light-emitting device;

FIG. 66B is a plan view of the light-emitting apparatus illustrated in FIG. 66A, viewed from above;

FIG. 67A is a schematic cross-sectional view of still another light-emitting apparatus including a light-emitting device and a support for supporting the light-emitting device;

FIG. 67B is a plan view of the light-emitting apparatus illustrated in FIG. 67A, viewed from above;

FIG. 68A is a schematic cross-sectional view of still another light-emitting apparatus including a light-emitting device and a support for supporting the light-emitting device;

FIG. 68B is a plan view of the light-emitting apparatus illustrated in FIG. 68A, viewed from above;

FIG. 69A is a schematic cross-sectional view of still another light-emitting apparatus including a light-emitting device and a support for supporting the light-emitting device;

FIG. 69B is a plan view of the light-emitting apparatus illustrated in FIG. 69A, viewed from above;

FIG. 70A is a schematic cross-sectional view of still another light-emitting apparatus including a light-emitting device and a support for supporting the light-emitting device;

FIG. 70B is a plan view of the light-emitting apparatus illustrated in FIG. 70A, viewed from above;

FIG. 71A is a schematic cross-sectional view of still another light-emitting apparatus including a light-emitting device and a support for supporting the light-emitting device;

FIG. 71B is a plan view of the light-emitting apparatus illustrated in FIG. 71A, viewed from above;

FIG. 72A is a schematic cross-sectional view of still another light-emitting apparatus including a light-emitting device and a support for supporting the light-emitting device;

FIG. 72B is a plan view of the light-emitting apparatus illustrated in FIG. 72A, viewed from above;

FIG. 73A is a schematic cross-sectional view of still another light-emitting apparatus including a light-emitting device and a support for supporting the light-emitting device;

FIG. 73B is a plan view of the light-emitting apparatus illustrated in FIG. 73A, viewed from above;

FIG. 74A is a schematic cross-sectional view of still another light-emitting apparatus including a light-emitting device and a support for supporting the light-emitting device;

FIG. 74B is a plan view of the light-emitting apparatus illustrated in FIG. 74A, viewed from above;

FIG. 75A is a schematic cross-sectional view of still another light-emitting apparatus including a light-emitting device and a support for supporting the light-emitting device;

FIG. 75B is a plan view of the light-emitting apparatus illustrated in FIG. 75A, viewed from above;

FIG. 76A is a schematic plan view of still another light-emitting apparatus including a light-emitting device and a support for supporting the light-emitting device;

FIG. 76B is a schematic plan view of still another light-emitting apparatus including a light-emitting device and a support for supporting the light-emitting device;

FIG. 77 is a schematic view of the structure of a light-emitting apparatus including a reflector;

FIG. 78 is a schematic view of the structure of a light-emitting apparatus including no reflector;

FIG. 79 is a schematic view of the structure of another light-emitting apparatus including a reflector;

FIG. 80 is a schematic view of a light-emitting apparatus including a support;

FIG. 81 is a schematic view of another light-emitting apparatus including a support;

FIG. 82 is a schematic view of still another light-emitting apparatus including a support;

FIG. 83 is a schematic view of a light-emitting apparatus including an excitation light source and a light-emitting device supported by a support;

FIG. 84A is a schematic view indicating the size of a lighting apparatus including a known light-emitting device;

FIG. 84B is a schematic view indicating the size of a lighting apparatus including a light-emitting device according to an embodiment of the present disclosure;

FIG. 84C is a schematic view indicating the size of a lighting apparatus including a light-emitting device according to an embodiment of the present disclosure and a reflector;

FIG. 85 is a schematic view of a light-emitting apparatus for synthesizing light beams emitted from light sources;

FIG. 86 is a detailed view of a light-emitting apparatus for synthesizing light beams emitted from light sources;

FIG. 87 is a schematic view of a light-emitting apparatus in which an additional light source also emits excitation light;

FIG. 88 is a schematic view of another light-emitting apparatus for synthesizing light beams emitted from light sources;

FIG. 89 is a schematic view of still another light-emitting apparatus for synthesizing light beams emitted from light sources;

FIG. 90 is a schematic view of still another light-emitting apparatus for synthesizing light beams emitted from light sources;

FIG. 91 is a schematic view of still another light-emitting apparatus for synthesizing light beams emitted from light sources;

FIG. 92 is a schematic view of still another light-emitting apparatus for synthesizing light beams emitted from light sources;

FIG. 93 is a schematic view of still another light-emitting apparatus for synthesizing light beams emitted from light sources;

FIG. 94 is a schematic view of still another light-emitting apparatus for synthesizing light beams emitted from light sources;

FIG. 95 is a schematic view of still another light-emitting apparatus for synthesizing light beams emitted from light sources;

FIG. 96 is a schematic view of a household fiber lighting system as an application example;

FIG. 97 is a schematic view of a light-emitting apparatus for synthesizing light beams in different wavelength ranges emitted in different directions from a light-emitting device;

FIG. 98 is a detailed view of a light-emitting apparatus for synthesizing light beams in different wavelength ranges;

FIG. 99 is a schematic view of a light-emitting apparatus for producing white light by synthesizing light beams of three particular wavelengths;

FIG. 100 is a schematic view illustrating first light in a first direction and second light in a second direction emitted from a light-emitting device into different optical fibers;

FIG. 101 is a schematic view of another light-emitting apparatus including coupled optical fibers;

FIG. 102 is a schematic view of a structure including tiled light-emitting devices instead of the light-emitting device illustrated in FIG. 101;

FIG. 103 is a schematic view of a structure in which part of light emitted from an excitation light source is utilized in the structure illustrated in FIG. 97;

FIG. 104 is a schematic view of a structure in which the position of the excitation light source illustrated in FIG. 103 was changed;

FIG. 105 is a schematic view of a structure in which part of light emitted from an excitation light source is utilized in the structure illustrated in FIG. 100;

FIG. 106 is a schematic view of a household fiber lighting system as an application example; and

FIG. 107 is a schematic cross-sectional view of a surface structure having projections or recesses or both.

DETAILED DESCRIPTION

A light-emitting apparatus according to an embodiment of the present disclosure includes an excitation light source, a light-emitting device on an optical path of excitation light emitted from the excitation light source, and a converging lens on an optical path of light emitted from the light-emitting device. The light-emitting device includes a photoluminescent layer for emitting light having a wavelength λ_a in air upon receiving excitation light. As will be described in detail later, a light-emitting device of a light-emitting apparatus according to the present disclosure has a novel structure in which the luminous efficiency, directionality, or polarization characteristics of a photoluminescent material can be controlled. An embodiment of the present disclosure can provide a light-emitting apparatus having a novel structure that utilizes a photoluminescent material. A light-emitting device for use in a light-emitting apparatus according to the present disclosure will be described below. The entire structure of the light-emitting apparatus will be described in detail later.

A light-emitting device according to an embodiment of the present disclosure includes a photoluminescent layer, a light-transmissive layer located on or near the photoluminescent layer, and a surface structure formed on a surface of at least one of the photoluminescent layer and the light-transmissive layer and having projections or recesses or both. The surface structure limits the directional angle of the light having the wavelength λ_a in air emitted from the photoluminescent layer. The surface structure may be a submicron structure on the photoluminescent layer or light-transmissive layer. For example, the submicron structure may be a periodic structure having projections or recesses or both. For example, the submicron structure has projections or recesses. Light from the photoluminescent layer includes first light having a wavelength λ_a in air, and the distance D_{int} between adjacent projections or recesses and the refractive index n_{wav-a} of the photoluminescent layer for the first light satisfy $\lambda_a/n_{wav-a} < D_{int} < \lambda_a$. In other words, the periodic structure has a period p_a that satisfies $\lambda_a/n_{wav-a} < p_a < \lambda_a$. The wavelength λ_a may be in the visible wavelength range (for example, 380 to 780 nm). When infrared light is used, the wavelength λ_a may be more than 780 nm. When ultraviolet light is used, the wavelength λ_a may be less than 380 nm. In the present disclosure, all electromagnetic waves, including infrared light and ultraviolet light, are referred to as "light" for convenience.

The photoluminescent layer contains a photoluminescent material. The term "photoluminescent material" refers to a material that emits light in response to excitation light. The

term "photoluminescent material" encompasses fluorescent materials and phosphorescent materials in a narrow sense, encompasses inorganic materials and organic materials (for example, dyes), and encompasses quantum dots (that is, tiny semiconductor particles). The photoluminescent layer may contain a matrix material (host material) in addition to the photoluminescent material. Examples of matrix materials include resins and inorganic materials, such as glasses and oxides.

The light-transmissive layer located on or near the photoluminescent layer is formed of a material, for example, an inorganic material or resin, having high transmittance to light emitted from the photoluminescent layer. For example, the light-transmissive layer can be formed of a dielectric material (particularly, an insulator having low light absorptivity). The light-transmissive layer may also be a substrate that supports the photoluminescent layer. If the surface of the photoluminescent layer exposed to air has a submicron structure, an air layer can serve as the light-transmissive layer.

A surface structure having projections or recesses or both is formed on a surface of at least one of the photoluminescent layer and the light-transmissive layer. The term "surface", as used herein, refers to a portion in contact with another substance (that is, an interface). If the light-transmissive layer is a gas layer, such as air, the interface between the gas layer and another substance (for example, the photoluminescent layer) is a surface of the light-transmissive layer. This surface structure can also be referred to as a "texture". The surface structure typically has projections or recesses periodically arranged in one or two dimension. Such a surface structure can be referred to as a "periodic structure". The projections and recesses are formed at the boundary between two adjoining members (or media) having different refractive indices. Thus, the "periodic structure" has a refractive index that varies periodically in a certain direction. The term "periodically" refers not only to periodically in the strict sense but also to approximately periodically. In the present specification, the distance between any two adjacent centers (hereinafter also referred to as the "center distance") of continuous projections or recesses in a periodic structure having a period p varies within $\pm 15\%$ of p .

The term "projection", as used herein, refers to a raised portion higher than the reference height. The term "recess", as used herein, refers to a recessed portion lower than the reference height. When projections and recesses have a particular shape, size, or distribution, it may be difficult to distinguish between projections and recesses. For example, in a cross-sectional view of FIG. 107, a member 610 has recesses, and a member 620 has projections, or alternatively the member 610 has projections, and the member 620 has recesses. In either case, each of the member 610 and the member 620 has projections or recesses or both.

The distance between the centers of two adjacent projections or recesses in the surface structure (the period p in the case of a periodic structure) is typically shorter than the wavelength λ_a in air of light emitted from the photoluminescent layer. The distance is submicron if light emitted from the photoluminescent layer is visible light, near-infrared light having a short wavelength, or ultraviolet light. Thus, such a surface structure is sometimes referred to as a "submicron structure". The "submicron structure" may partly have a center distance or period of more than 1 micrometer (μm). In the following description, it is assumed that the photoluminescent layer principally emits visible light, and the surface structure may be a "submicron struc-

ture". However, the following description can also be applied to a surface structure having a micrometer structure (for example, a micrometer structure used in combination with infrared light).

In an embodiment of the present disclosure, a unique electric field distribution is formed inside the photoluminescent layer and the light-transmissive layer, as described in detail later with reference to the results of calculations and experiments. Such an electric field distribution is formed by an interaction between guided light and a submicron structure (that is, a surface structure). Such an electric field distribution is formed in an optical mode referred to as a "quasi-guided mode". A quasi-guided mode can be utilized to improve the luminous efficiency, directionality, and polarization selectivity of photoluminescence, as described later. The term "quasi-guided mode" may be used in the following description to describe novel structures and/or mechanisms contemplated by the present inventors. Such a description is for illustrative purposes only and is not intended to limit the present disclosure in any way.

For example, the submicron structure has projections and satisfies the relationship $\lambda_a/n_{wav-a} < D_{int} < \lambda_a$, where D_{int} is the center-to-center distance between adjacent projections. Instead of the projections, the submicron structure may have recesses. For simplicity, the following description will be directed to a submicron structure having projections. The symbol λ denotes the wavelength of light, and the symbol λ_a with a subscript "a" denotes the wavelength of light in air. The symbol n_{wav} denotes the refractive index of the photoluminescent layer. If the photoluminescent layer is formed of a medium containing a mixture of materials, the refractive index n_{wav} represents the average of the refractive indices of the materials weighted by their respective volume fractions. Although it is desirable to use the symbol n_{wav-a} to refer to the refractive index for light having a wavelength λ_a because the refractive index n generally depends on the wavelength, it may be abbreviated for simplicity. The symbol n_{wav} basically denotes the refractive index of the photoluminescent layer, however, if a layer having a higher refractive index than the photoluminescent layer is adjacent to the photoluminescent layer, the refractive index n_{wav} represents the average of the refractive indices of the layer having the higher refractive index and the photoluminescent layer weighted by their respective volume fractions. This situation is optically equivalent to a photoluminescent layer composed of layers of different materials.

The effective refractive index n_{eff} of the medium for light in a quasi-guided mode satisfies $n_a < n_{eff} < n_{wav}$, wherein n_a denotes the refractive index of air. If light in a quasi-guided mode propagates through the photoluminescent layer while being totally reflected at an incident angle θ , the effective refractive index n_{eff} can be written as $n_{eff} = n_{wav} \sin \theta$. The effective refractive index n_{eff} is determined by the refractive index of the medium present in the region where the electric field of a quasi-guided mode is distributed. For example, if the submicron structure is formed in the light-transmissive layer, the effective refractive index n_{eff} depends not only on the refractive index of the photoluminescent layer but also on the refractive index of the light-transmissive layer. Because the electric field distribution also varies with the polarization direction of a quasi-guided mode (TE mode or TM mode), the effective refractive index n_{eff} can differ between the TE mode and the TM mode.

The submicron structure is formed on at least one of the photoluminescent layer and the light-transmissive layer. If the photoluminescent layer and the light-transmissive layer are in contact with each other, the submicron structure may

be formed at the interface between the photoluminescent layer and the light-transmissive layer. In such a case, the photoluminescent layer and the light-transmissive layer have the submicron structure. The photoluminescent layer may have no submicron structure. In such a case, a light-transmissive layer having a submicron structure is located on or near the photoluminescent layer. A phrase like "a light-transmissive layer (or its submicron structure) located on or near the photoluminescent layer", as used herein, typically means that the distance between these layers is less than half the wavelength λ_a . This allows the electric field in a guided mode to reach the submicron structure, thus forming a quasi-guided mode. However, the distance between the submicron structure of the light-transmissive layer and the photoluminescent layer may exceed half the wavelength λ_a if the light-transmissive layer has a higher refractive index than the photoluminescent layer, because light reaches the light-transmissive layer even if the above relationship is not satisfied. In the present specification, if the photoluminescent layer and the light-transmissive layer have a positional relationship that allows the electric field in a guided mode to reach the submicron structure and form a quasi-guided mode, they may be associated with each other.

If the submicron structure satisfies $\lambda_a/n_{wav-a} < D_{int} < \lambda_a$ as described above, the surface structure is characterized by a submicron size in applications utilizing visible light. The submicron structure can include at least one periodic structure, as in the light-emitting devices of light-emitting apparatuses according to the embodiments described in detail later. The at least one periodic structure has a period p_a that can satisfy $\lambda_a/n_{wav-a} < p_a < \lambda_a$. Thus, the submicron structure can include a periodic structure in which the distance D_{int} between adjacent projections is constant at p_a . If the submicron structure includes such a periodic structure, light in a quasi-guided mode propagates while repeatedly interacting with the periodic structure so that the light is diffracted by the submicron structure. Unlike the phenomenon in which light propagating through free space is diffracted by a periodic structure, this is the phenomenon in which light is guided (that is, repeatedly totally reflected) while interacting with the periodic structure. This can efficiently diffract light even if the periodic structure causes a small phase shift (that is, even if the periodic structure has a small height).

The above mechanism can be utilized to improve the luminous efficiency of photoluminescence by the enhancement of the electric field due to a quasi-guided mode and also to couple emitted light to the quasi-guided mode. The angle of travel of light in a quasi-guided mode is changed by the angle of diffraction determined by the periodic structure. This can be utilized to emit light having a particular wavelength in a particular direction. This can significantly improve directionality as compared with submicron structures including no periodic structure. Furthermore, high polarization selectivity can be simultaneously achieved because the effective refractive index n_{eff} ($=n_{wav} \sin \theta$) differs between the TE mode and the TM mode. For example, as demonstrated by the experimental examples below, a light-emitting device can be provided that emits intense linearly polarized light (for example, the TM mode) of a particular wavelength (for example, 610 nm) in the front direction. The directional angle of light emitted in the front direction is less than 15 degrees, for example. The term "directional angle", as used herein, refers to the angle between the direction of maximum intensity and the direction of 50% of the maximum intensity of linearly polarized light having a particular wavelength to be emitted. In other

words, the term “directional angle” refers to the angle of one side with respect to the direction of maximum intensity, which is assumed to be 0 degrees. Thus, the periodic structure (that is, surface structure) in an embodiment of the present disclosure limits the directional angle of light having a particular wavelength λ_a . In other words, the distribution of light having the wavelength λ_a is narrowed as compared with submicron structures including no periodic structure. Such a light distribution in which the directional angle is narrowed as compared with submicron structures including no periodic structure is sometimes referred to as a “narrow-angle light distribution”. Although the periodic structure in an embodiment of the present disclosure limits the directional angle of light having the wavelength λ_a , the periodic structure does not necessarily emit the entire light having the wavelength λ_a at narrow angles. For example, in an embodiment described later in FIG. 29, light having the wavelength λ_a is slightly emitted in a direction (for example, at an angle in the range of 20 to 70 degrees) away from the direction of maximum intensity. However, as a whole, emitted light having the wavelength λ_a mostly has an angle in the range of 0 to 20 degrees and has limited directional angles.

Unlike general diffraction gratings, the periodic structure in a typical embodiment of the present disclosure has a shorter period than the light wavelength λ_a . General diffraction gratings have a sufficiently longer period than the light wavelength λ_a , and consequently light having a particular wavelength is divided into diffracted light emissions, such as zero-order light (that is, transmitted light) and ± 1 -order diffracted light. In such diffraction gratings, higher-order diffracted light is generated on both sides of zero-order light. Higher-order diffracted light generated on both sides of zero-order light in diffraction grating makes it difficult to provide a narrow-angle light distribution. In other words, known diffraction gratings do not have the effect of limiting the directional angle of light to a predetermined angle (for example, approximately 15 degrees), which is a characteristic effect of an embodiment of the present disclosure. In this regard, the periodic structure according to an embodiment of the present disclosure is significantly different from known diffraction gratings.

A submicron structure having lower periodicity results in lower directionality, luminous efficiency, polarization, and wavelength selectivity. The periodicity of the submicron structure may be adjusted depending on the need. The periodic structure may be a one-dimensional periodic structure, which has higher polarization selectivity, or a two-dimensional periodic structure, which allows for lower polarization.

The submicron structure may include periodic structures. For example, these periodic structures may have different periods (itches) or different periodic directions (axes). The periodic structures may be formed on the same plane or may be stacked on top of each other. The light-emitting device may include photoluminescent layers and light-transmissive layers, and each of the layers may have submicron structures.

The submicron structure can be used not only to control light emitted from the photoluminescent layer but also to efficiently guide excitation light into the photoluminescent layer. That is, excitation light can be diffracted by the submicron structure and coupled to a quasi-guided mode that guides light in the photoluminescent layer and the light-transmissive layer and thereby can efficiently excite the photoluminescent layer. The submicron structure satisfies $\lambda_{ex}/n_{wav-ex} < D_{int} < \lambda_{ex}$, wherein λ_{ex} denotes the wavelength of excitation light in air, the excitation light exciting the

photoluminescent material, and n_{wav-ex} denotes the refractive index of the photoluminescent layer for the excitation light. The symbol n_{wav-ex} denotes the refractive index of the photoluminescent layer at the emission wavelength of the photoluminescent material. Alternatively, the submicron structure may include a periodic structure having a period p_{ex} that satisfies $\lambda_{ex}/n_{wav-ex} < p_{ex} < \lambda_{ex}$. The excitation light has a wavelength λ_{ex} of 450 nm, for example, but may have a shorter wavelength than visible light. If the excitation light has a wavelength in the visible range, the excitation light may be emitted together with light emitted from the photoluminescent layer.

1. Underlying Knowledge Forming Basis of the Present Disclosure

The underlying knowledge forming the basis for the present disclosure will be described before describing specific embodiments of the present disclosure, and then an exemplary structure of a light-emitting device including a photoluminescent layer will be described. As described above, photoluminescent materials, such as those used for fluorescent lamps and white light-emitting diodes (LEDs), emit light in all directions. Thus, in general, such photoluminescent materials are used in combination with optical elements, such as reflectors and lenses, to emit light in a particular direction. However, the size of such an optical element, for example, a lens can be decreased if the photoluminescent layer itself emits directional light. This results in a significant reduction in the size of optical devices and equipment. With this idea in mind, the present inventors have conducted a detailed study on the photoluminescent layer to achieve directional light emission.

The present inventors have investigated the possibility of inducing light emission with particular directionality so that light from the photoluminescent layer is localized in a particular direction. Based on Fermi’s golden rule, the emission rate Γ , which is a measure characterizing light emission, is represented by the formula (1):

$$\Gamma(r) = \frac{2\pi}{h} \langle (d \cdot E(r)) \rangle^2 \rho(\lambda) \quad (1)$$

In the formula (1), r denotes the vector indicating the position, λ denotes the wavelength of light, d denotes the dipole vector, E denotes the electric field vector, and ρ denotes the density of states. In many substances other than some crystalline substances, the dipole vector d is randomly oriented. The magnitude of the electric field E is substantially constant irrespective of the direction if the size and thickness of the photoluminescent layer are sufficiently larger than the wavelength of light. Hence, in most cases, the value of $\langle (d \cdot E(r)) \rangle^2$ is independent of the direction. Accordingly, the emission rate Γ is constant irrespective of the direction. Thus, in most cases, the photoluminescent layer emits light in all directions.

As can be seen from the formula (1), to achieve anisotropic light emission, it is necessary to align the dipole vector d in a particular direction or to enhance a component of the electric field vector in a particular direction. One of these approaches can be employed to achieve directional light emission. Embodiments of the present disclosure utilize a quasi-guided mode in which an electric field component in a particular direction is enhanced by confinement of

light in a photoluminescent layer. Structures for utilizing a quasi-guided mode have been studied and analyzed in detail as described below.

2. Structure for Enhancing Electric Field Only in Particular Direction

The present inventors have investigated the possibility of controlling light emission using a guided mode with an intense electric field. Light can be coupled to a guided mode using a waveguide structure that itself contains a photoluminescent material. However, a waveguide structure simply formed using a photoluminescent material emits little or no light in the front direction because the emitted light is coupled to a guided mode. Accordingly, the present inventors have investigated the possibility of combining a waveguide containing a photoluminescent material with a periodic structure. When the electric field of light is guided in a waveguide while overlapping with a periodic structure located on or near the waveguide, a quasi-guided mode is formed by the effect of the periodic structure. That is, a quasi-guided mode is a guided mode restricted by the periodic structure and is characterized in that the antinodes of the amplitude of the electric field have the same period as the periodic structure. Light in this mode is confined in the waveguide structure to enhance the electric field in a particular direction. This mode also interacts with the periodic structure and undergoes diffraction, so that light in this mode is converted into light propagating in a particular direction and can be emitted from the waveguide. The electric field of light other than quasi-guided modes is not enhanced because little or no such light is confined in the waveguide. Thus, most light is coupled to a quasi-guided mode with a large electric field component.

That is, the present inventors have investigated the possibility of using a photoluminescent layer containing a photoluminescent material as a waveguide (or a waveguide layer including a photoluminescent layer) in combination with a periodic structure located on or near the waveguide to couple light to a quasi-guided mode in which the light is converted into light propagating in a particular direction, thereby providing a directional light source.

As a simple waveguide structure, the present inventors have studied slab waveguides. A slab waveguide has a planar structure in which light is guided. FIG. 30 is a schematic perspective view of a slab waveguide. In FIG. 30, there is a mode of light propagating through a waveguide 110S if the waveguide 110S has a higher refractive index than a substrate 140 that supports the waveguide 110S. If such a slab waveguide includes a photoluminescent layer, the electric field of light emitted from an emission point overlaps largely with the electric field of a guided mode. This allows most of the light emitted from the photoluminescent layer to be coupled to the guided mode. If the photoluminescent layer has a thickness close to the wavelength of light, a situation can be created where there is only a guided mode with a large electric field amplitude.

If a periodic structure is located on or near the photoluminescent layer, the electric field of a guided mode interacts with the periodic structure to form a quasi-guided mode. Even if the photoluminescent layer is composed of multiple layers, a quasi-guided mode can be formed as long as the electric field of a guided mode reaches the periodic structure. Not all of the photoluminescent layer needs to be formed of a photoluminescent material, provided that at least a portion of the photoluminescent layer functions to emit light.

If the periodic structure is made of a metal, a mode due to a guided mode and plasmon resonance is formed. This mode has different properties from the quasi-guided mode described above and is less effective in enhancing emission because a large loss occurs due to high absorption by the metal. Thus, it is advantageous to form the periodic structure using a dielectric material having low absorptivity.

The present inventors have studied the coupling of light to a quasi-guided mode that can be emitted as light propagating in a particular angular direction using a periodic structure formed on a waveguide. FIG. 1A is a schematic perspective view of a light-emitting device 100 including a waveguide (for example, a photoluminescent layer) 110 and a periodic structure (for example, part of a light-transmissive layer) 120. If the light-transmissive layer has a periodic structure (that is, if a periodic submicron structure is formed on the light-transmissive layer), the surface structure 120 is sometimes referred to as a "light-transmissive layer 120". In this example, the surface structure 120 is a one-dimensional periodic structure in which stripe-shaped projections extending in the y direction are arranged at regular intervals in the x direction. FIG. 1B is a cross-sectional view of the light-emitting device 100 taken along a plane parallel to the xz plane. If a periodic structure having a period p is provided in contact with the waveguide 110, a quasi-guided mode having a wave number k_{wav} in the in-plane direction is converted into light propagating outside the waveguide 110. The wave number k_{out} of the light can be represented by the formula (2):

$$k_{out} = k_{wav} - m \frac{2\pi}{p} \quad (2)$$

In the formula (2), m is an integer indicating the diffraction order.

For simplicity, light guided in the waveguide 110 is assumed to be a ray of light propagating at an angle θ_{wav} . This approximation gives the formulae (3) and (4):

$$\frac{k_{wav}\lambda_0}{2\pi} = n_{wav}\sin\theta_{wav} \quad (3)$$

$$\frac{k_{out}\lambda_0}{2\pi} = n_{out}\sin\theta_{out} \quad (4)$$

In these formulae, λ_0 denotes the wavelength of the light in air, n_{wav} denotes the refractive index of the waveguide 110, n_{out} denotes the refractive index of the medium on the light emission side, and θ_{out} denotes the angle at which the light is emitted from the waveguide 110 to a substrate or to the air. From the formulae (2) to (4), the output angle θ_{out} can be represented by the equation (5):

$$n_{out} \sin \theta_{out} = n_{wav} \sin \theta_{wav} - m\lambda_0/p \quad (5)$$

If $n_{wav} \sin \theta_{wav} = m\lambda_0/p$ in the formula (5), this results in $\theta_{out} = 0$, meaning that the light can be emitted in the direction perpendicular to the plane of the waveguide 110 (that is, in the front direction).

Based on this principle, light can be coupled to a particular quasi-guided mode and be converted into light having a particular output angle using the periodic structure to emit intense light in that direction.

There are some constraints to achieving the above situation. To form a quasi-guided mode, light propagating

through the waveguide **110** has to be totally reflected. The conditions therefor are represented by the formula (6):

$$n_{out} < n_{wav} \sin \theta_{wav} \quad (6)$$

To diffract a quasi-guided mode using the periodic structure and thereby emit light from the waveguide **110**, $-1 < \sin \theta_{out} < 1$ has to be satisfied in the formula (5). Hence, the following formula (7) has to be satisfied:

$$-1 < \frac{n_{wav}}{n_{out}} \sin \theta_{wav} - \frac{m\lambda_0}{n_{out}p} < 1 \quad (7)$$

Taking into account the formula (6), the formula (8) has to be satisfied:

$$\frac{m\lambda_0}{2n_{out}} < p \quad (8)$$

To emit light from the waveguide **110** in the front direction ($\theta_{out}=0$), as can be seen from the formula (5), the formula (9) has to be satisfied:

$$p = m\lambda_0 / (n_{wav} \sin \theta_{wav}) \quad (9)$$

As can be seen from the formulae (9) and (6), the required conditions are represented by the formula (10):

$$\frac{m\lambda_0}{n_{wav}} < p < \frac{m\lambda_0}{n_{out}} \quad (10)$$

The periodic structure as illustrated in FIGS. **1A** and **1B** may be designed based on first-order diffracted light (that is, $m=1$) because higher-order diffracted light having m of 2 or more has low diffraction efficiency. In a typical embodiment of the present disclosure, the period p of the periodic structure is determined so as to satisfy the formula (11), which is given by substituting $m=1$ into the formula (10):

$$\frac{\lambda_0}{n_{wav}} < p < \frac{\lambda_0}{n_{out}} \quad (11)$$

If the waveguide (for example, the photoluminescent layer) **110** is not in contact with a transparent substrate, as illustrated in FIGS. **1A** and **1B**, n_{out} is equal to the refractive index of air (approximately 1.0). Thus, the period p is determined so as to satisfy the formula (12):

$$\frac{\lambda_0}{n_{wav}} < p < \lambda_0 \quad (12)$$

Alternatively, a structure as illustrated in FIGS. **1C** and **1D** may be employed in which a photoluminescent layer serving as the waveguide **110** and the surface structure **120** are formed on a substrate **140**. The substrate **140** is typically a transparent substrate. The substrate **140** is hereinafter also referred to as a transparent substrate **140**.

When the waveguide **110** and the surface structure **120** are formed on the transparent substrate **140**, since the refractive index n_s of the transparent substrate **140** is higher than the refractive index of air, the period p is determined so as to satisfy the following formula (13), which is given by substituting $n_{out}=n_s$ into the formula (11):

$$\frac{\lambda_0}{n_{wav}} < p < \frac{\lambda_0}{n_s} \quad (13)$$

Although $m=1$ is assumed in the formula (10) to give the formulae (12) and (13), m may be 2 or more. That is, if both surfaces of the light-emitting device **100** are in contact with air layers, as shown in FIGS. **1A** and **1B**, the period p is determined so as to satisfy the formula (14):

$$\frac{m\lambda_0}{n_{wav}} < p < m\lambda_0 \quad (14)$$

wherein m is an integer of 1 or more.

Likewise, as in a light-emitting device **100a** illustrated in FIGS. **1C** and **1D**, if a photoluminescent layer serving as the waveguide **110** is formed on the transparent substrate **140**, the period p is determined so as to satisfy the following formula (15):

$$\frac{m\lambda_0}{n_{wav}} < p < \frac{m\lambda_0}{n_s} \quad (15)$$

By determining the period p of the periodic structure so as to satisfy the above formulae, light from the photoluminescent layer can be emitted in the front direction. Thus, a directional light-emitting apparatus can be provided. The waveguide **110** is hereinafter also referred to as a photoluminescent layer **110**.

3. Verification by Calculations

3-1. Period and Wavelength Dependence

The present inventors verified, by optical analysis, whether light emission in a particular direction as described above is actually possible. The optical analysis was performed by calculations using DiffractMOD available from Cybernet Systems Co., Ltd. In these calculations, the change in the absorption of external light incident perpendicular to a light-emitting device by a photoluminescent layer was calculated to determine the enhancement of light output perpendicular to the light-emitting device. The calculation of the process by which external incident light is coupled to a quasi-guided mode and is absorbed by the photoluminescent layer corresponds to the calculation of a process opposite to the process by which light emitted from the photoluminescent layer is coupled to a quasi-guided mode and is converted into propagating light output perpendicular to the light-emitting device. Similarly, the electric field distribution of a quasi-guided mode was calculated from the electric field of external incident light.

FIG. **2** shows the calculation results of the enhancement of light emitted in the front direction with varying emission wavelengths and varying periods of the periodic structure. The photoluminescent layer had a thickness of 1 μm and a refractive index n_{wav} of 1.8, and the periodic structure had a height of 50 nm and a refractive index of 1.5. In these calculations, the periodic structure was a one-dimensional periodic structure uniform in the y direction, as illustrated in FIG. **1A**, and the polarization of light was in the TM mode, which has an electric field component parallel to the y direction. The results in FIG. **2** show that there are enhancement peaks at certain combinations of wavelength and period. In FIG. **2**, the magnitude of the enhancement is

expressed by different shades of color; a darker color (black) indicates a higher enhancement, whereas a lighter color (white) indicates a lower enhancement.

In the above calculations, the periodic structure had a rectangular cross section as illustrated in FIG. 1B. FIG. 3 is a graph illustrating the conditions for $m=1$ and $m=3$ in the formula (10). A comparison between FIGS. 2 and 3 shows that the peaks in FIG. 2 are located within the regions corresponding to $m=1$ and $m=3$. The intensity is higher for $m=1$ because first-order diffracted light has a higher diffraction efficiency than third- or higher-order diffracted light. There is no peak for $m=2$ because of low diffraction efficiency in the periodic structure.

In FIG. 2, a plurality of lines are observed in each of the regions corresponding to $m=1$ and $m=3$ in FIG. 3. This indicates the presence of a plurality of quasi-guided modes.

3-2. Thickness Dependence

FIG. 4 is a graph showing the calculation results of the enhancement of light emitted in the front direction with varying emission wavelengths and varying thicknesses t of the photoluminescent layer. The photoluminescent layer had a refractive index $n_{w,av}$ of 1.8, and the periodic structure had a period of 400 nm, a height of 50 nm, and a refractive index of 1.5. FIG. 4 shows that the enhancement of light is highest at a particular thickness t of the photoluminescent layer.

FIGS. 5A and 5B show the calculation results of the electric field distributions in a mode to guide light in the x direction for a wavelength of 600 nm and thicknesses t of 238 nm and 539 nm, respectively, at which there are peaks in FIG. 4. For comparison, FIG. 5C shows the results of similar calculations for a thickness t of 300 nm, at which there is no peak. In these calculations, as in the above calculations, the periodic structure was a one-dimensional periodic structure uniform in the y direction. In each figure, a darker region has higher electric field strength, and a lighter region has lower electric field strength. Whereas the results for $t=238$ nm and $t=539$ nm show high electric field strength, the results for $t=300$ nm show low electric field strength as a whole. This is because there is a guided mode in the case of $t=238$ or 539 nm, so that light is strongly confined. Furthermore, regions with the highest electric field strength (antinodes) are always present in or directly below the projections, indicating the correlation between the electric field and the surface structure **120** (the periodic structure in this example). Thus, the resulting guided mode depends on the arrangement of the surface structure **120**. A comparison between the results for $t=238$ nm and $t=539$ nm shows that these modes differ by one in the number of nodes (white regions) of the electric field in the z direction.

3-3. Polarization Dependence

To examine the polarization dependence, the enhancement of light was calculated under the same conditions as in FIG. 2 except that the polarization of light was in the TE mode, which has an electric field component perpendicular to the y direction. FIG. 6 shows the calculation results. Although the peaks in FIG. 6 differ slightly in position from the peaks for the TM mode (FIG. 2), they are located within the regions shown in FIG. 3. This demonstrates that the structure according to this embodiment is effective for both the TM mode and the TE mode.

3-4. Two-Dimensional Periodic Structure

The effect of a two-dimensional periodic structure has also been studied. FIG. 7A is a partial plan view of a two-dimensional surface structure **120'** including recesses and projections arranged in both the x direction and the y direction. In FIG. 7A, black regions represent projections, and white regions represent recesses. For a two-dimensional

periodic structure, both the diffraction in the x direction and the diffraction in the y direction have to be taken into account. Although the diffraction only in the x or y direction is similar to that in a one-dimensional periodic structure, a two-dimensional periodic structure can be expected to give different results from the one-dimensional periodic structure because diffraction also occurs in a direction containing both an x component and a y component (for example, at an angle of 45 degrees). FIG. 7B shows the calculation results of the enhancement of light for the two-dimensional periodic structure. The calculations were performed under the same conditions as in FIG. 2 except for the type of periodic structure. As shown in FIG. 7B, peaks matching the peaks for the TE mode in FIG. 6 were observed in addition to peaks matching the peaks for the TM mode in FIG. 2. These results demonstrate that the two-dimensional periodic structure also converts and outputs the TE mode by diffraction. For a two-dimensional periodic structure, diffraction that simultaneously satisfies the first-order diffraction conditions in both the x direction and the y direction also has to be taken into account. Such diffracted light is emitted at an angle corresponding to $\sqrt{2}$ times (that is, $2^{1/2}$ times) the period p . Thus, peaks will occur at $\sqrt{2}$ times the period p in addition to peaks that occur in a one-dimensional periodic structure. Such peaks are also observed in FIG. 7B.

The two-dimensional periodic structure does not have to be a square grid structure having equal periods in the x direction and the y direction, as illustrated in FIG. 7A, but may be a hexagonal grid structure, as illustrated in FIG. 18A, or a triangular grid structure, as illustrated in FIG. 18B. The two-dimensional periodic structure may have different periods in different directions (for example, in the x direction and the y direction for a square grid structure).

In this embodiment, as demonstrated above, light in a characteristic quasi-guided mode formed by the periodic structure and the photoluminescent layer can be selectively emitted only in the front direction through diffraction by the periodic structure. With this structure, the photoluminescent layer can be excited with excitation light such as ultraviolet light or blue light to emit directional light.

4. Study on Constructions of Periodic Structure and Photoluminescent Layer

The effects of changes in various conditions such as the constructions and refractive indices of the periodic structure and the photoluminescent layer will now be described.

4-1. Refractive Index of Periodic Structure

The refractive index of the periodic structure has been studied. In the calculations performed herein, the photoluminescent layer had a thickness of 200 nm and a refractive index $n_{w,av}$ of 1.8, the surface structure was a one-dimensional periodic structure uniform in the y direction, as illustrated in FIG. 1A, and had a height of 50 nm and a period of 400 nm, and the polarization of light was the TM mode, which has an electric field component parallel to the y direction. FIG. 8 shows the calculation results of the enhancement of light emitted in the front direction with varying emission wavelengths and varying refractive indices of the periodic structure. FIG. 9 shows the results obtained under the same conditions except that the photoluminescent layer had a thickness of 1,000 nm.

The results show that the photoluminescent layer having a thickness of 1,000 nm (FIG. 9) results in a smaller shift in the wavelength at which the light intensity is highest (the wavelength is hereinafter referred to as a peak wavelength) with the change in the refractive index of the periodic

structure than the photoluminescent layer having a thickness of 200 nm (FIG. 8). This is because the quasi-guided mode is more affected by the refractive index of the periodic structure as the photoluminescent layer is thinner. Specifically, a periodic structure having a higher refractive index increases the effective refractive index and thus shifts the peak wavelength toward longer wavelengths, and this effect is more noticeable as the photoluminescent layer is thinner. The effective refractive index is determined by the refractive index of a medium present in the region where the electric field of a quasi-guided mode is distributed.

The results also show that a periodic structure having a higher refractive index results in a broader peak and lower intensity. This is because a periodic structure having a higher refractive index emits light in a quasi-guided mode at a higher rate and is therefore less effective in confining light, that is, has a lower Q value. To maintain high peak intensity, a structure may be employed in which light is moderately emitted using a quasi-guided mode that is effective in confining light (that is, has a high Q value). This means that it is advantageous to use a periodic structure formed of a material not having a much higher refractive index than the photoluminescent layer. Thus, in order to increase the peak intensity and Q value, the refractive index of a dielectric material constituting the periodic structure (that is, the light-transmissive layer) can be lower than or similar to the refractive index of the photoluminescent layer. This is also true if the photoluminescent layer contains materials other than photoluminescent materials.

4-2. Height of Periodic Structure

The height of the periodic structure has been studied. In the calculations performed herein, the photoluminescent layer had a thickness of 1,000 nm and a refractive index n_{wav} of 1.8, the surface structure was a one-dimensional periodic structure uniform in the y direction, as illustrated in FIG. 1A, and had a refractive index n_p of 1.5 and a period of 400 nm, and the polarization of the light was the TM mode, which has an electric field component parallel to the y direction. FIG. 10 shows the calculation results of the enhancement of light emitted in the front direction with varying emission wavelengths and varying heights of the periodic structure. FIG. 11 shows the results of calculations performed under the same conditions except that the periodic structure has a refractive index n_p of 2.0. Whereas the results in FIG. 10 show that the peak intensity and the Q value (that is, the peak line width) do not change when the periodic structure has at least a certain height, the results in FIG. 11 show that the peak intensity and the Q value decrease with increasing height of the periodic structure. If the refractive index n_{wav} of the photoluminescent layer is higher than the refractive index n_p of the periodic structure (FIG. 10), light is totally reflected, and only a leaking (evanescent) portion of the electric field of a quasi-guided mode interacts with the periodic structure. If the periodic structure has a sufficiently large height, the influence of the interaction between the evanescent portion of the electric field and the periodic structure remains constant irrespective of the height. In contrast, if the refractive index n_{wav} of the photoluminescent layer is lower than the refractive index n_p of the periodic structure (FIG. 11), light reaches the surface of the periodic structure without being totally reflected and is therefore more influenced by the periodic structure with a larger height. As shown in FIG. 11, a height of approximately 100 nm is sufficient, and the peak intensity and the Q value decrease above a height of 150 nm. Thus, if the refractive index n_{wav} of the photoluminescent layer is lower than the refractive index n_p of the periodic structure, the periodic

structure may have a height of 150 nm or less to achieve a high peak intensity and Q value.

4-3. Polarization Direction

The polarization direction has been studied. FIG. 12 shows the results of calculations performed under the same conditions as in FIG. 9 except that the polarization of light was in the TE mode, which has an electric field component perpendicular to the y direction. The TE mode is more influenced by the periodic structure than the TM mode because the electric field of a quasi-guided mode leaks more largely in the TE mode than in the TM mode. Thus, the peak intensity and the Q value decrease more significantly in the TE mode than in the TM mode if the refractive index n_p of the periodic structure is higher than the refractive index n_{wav} of the photoluminescent layer.

4-4. Refractive Index of Photoluminescent Layer

The refractive index of the photoluminescent layer has been studied. FIG. 13 shows the results of calculations performed under the same conditions as in FIG. 9 except that the photoluminescent layer had a refractive index n_{wav} of 1.5. The results for the photoluminescent layer having a refractive index n_{wav} of 1.5 are similar to the results in FIG. 9. However, light having a wavelength of 600 nm or more was not emitted in the front direction. This is because, from the formula (10), $\lambda_0 < n_{wav} \times p/m = 1.5 \times 400 \text{ nm}/1 = 600 \text{ nm}$.

The above analysis demonstrates that a high peak intensity and Q value can be achieved if the periodic structure has a refractive index lower than or similar to the refractive index of the photoluminescent layer or if the periodic structure has a higher refractive index than the photoluminescent layer and a height of 150 nm or less.

5. Modified Examples

Modified examples of the embodiments of the light-emitting device will be described below.

5-1. Structure Including Substrate

The light-emitting device may have a structure in which the photoluminescent layer 110 and the surface structure 120 are formed on the transparent substrate 140, as illustrated in FIGS. 1C and 1D. Such a light-emitting device 100a may be produced by forming a thin film of the photoluminescent material for the photoluminescent layer 110 (optionally containing a matrix material; the same applies hereinafter) on the transparent substrate 140 and then forming the surface structure 120 thereon. In this structure, the refractive index n_s of the transparent substrate 140 has to be lower than or equal to the refractive index n_{wav} of the photoluminescent layer 110 so that the photoluminescent layer 110 and the surface structure 120 function to emit light in a particular direction. If the transparent substrate 140 is provided in contact with the photoluminescent layer 110, the period p is set so as to satisfy the formula (15), which is given by replacing the refractive index n_{out} of the output medium in the formula (10) by n_s .

To demonstrate this, calculations were performed under the same conditions as in FIG. 2 except that the photoluminescent layer 110 and the surface structure 120 were disposed on a transparent substrate 140 having a refractive index of 1.5. FIG. 14 shows the calculation results. As in the results in FIG. 2, light intensity peaks are observed at particular periods for each wavelength, although the ranges of periods where peaks appear differ from those in FIG. 2. FIG. 15 is a graph illustrating the condition represented by the formula (15), which is given by substituting $n_{out} = n_s$ into

the formula (10). In FIG. 14, light intensity peaks are observed in the regions corresponding to the ranges shown in FIG. 15.

Thus, for the light-emitting device 100a, in which the photoluminescent layer 110 and the surface structure 120 are disposed on the transparent substrate 140, a period p that satisfies the formula (15) is effective, and a period p that satisfies the formula (13) is significantly effective.

5-2. Light-Emitting Apparatus Including Excitation Light Source

FIG. 16 is a schematic view of a light-emitting apparatus 200 including the light-emitting device 100 illustrated in FIGS. 1A and 1B and a light source 180 that emits excitation light to the photoluminescent layer 110. In this embodiment, as described above, the photoluminescent layer can be excited with excitation light, such as ultraviolet light or blue light, and emit directional light. The light-emitting apparatus 200 including the light source 180 that can emit such excitation light can emit directional light. Although the wavelength of excitation light emitted from the light source 180 is typically in the ultraviolet or blue range, it is not necessarily within these ranges, but may be determined depending on the photoluminescent material for the photoluminescent layer 110. Although the light source 180 illustrated in FIG. 16 is configured to direct excitation light into the bottom surface of the photoluminescent layer 110, it may be configured otherwise, for example, to direct excitation light into the top surface of the photoluminescent layer 110. Excitation light may be directed at an angle (that is, obliquely) with respect to a direction perpendicular to a main surface (the top surface or the bottom surface) of the photoluminescent layer 110. Excitation light directed obliquely so as to be totally reflected in the photoluminescent layer 110 can more efficiently induce light emission from the photoluminescent layer 110.

Excitation light may be coupled to a quasi-guided mode to efficiently emit light. FIGS. 17A to 17D illustrate such a method. In this example, as in the structure illustrated in FIGS. 1C and 1D, the photoluminescent layer 110 and the surface structure 120 are formed on the transparent substrate 140. As illustrated in FIG. 17A, the period p_x in the x direction is first determined so as to enhance light emission. As illustrated in FIG. 17B, the period p_y in the y direction is then determined so as to couple excitation light to a quasi-guided mode. The period p_x is determined so as to satisfy the condition given by replacing p by p_x in the formula (10). The period p_y is determined so as to satisfy the formula (16): wherein m is an integer of 1 or more, λ_{ex} denotes the wavelength of excitation light, and n_{out} denotes the refractive index of a medium having the highest refractive index of the media in contact with the photoluminescent layer 110 except the surface structure 120.

$$\frac{m\lambda_{ex}}{n_{wav}} < p_y < \frac{m\lambda_{ex}}{n_{out}} \quad (16)$$

In the example in FIG. 17B, n_{out} denotes the refractive index n_s of the transparent substrate 140. For a structure including no transparent substrate 140, as illustrated in FIG. 16, n_{out} denotes the refractive index of air (approximately 1.0).

In particular, excitation light can be more effectively converted into a quasi-guided mode if $m=1$, that is, if the period p_y is determined so as to satisfy the formula (17):

$$\frac{\lambda_{ex}}{n_{wav}} < p < \frac{\lambda_{ex}}{n_{out}} \quad (17)$$

Thus, excitation light can be converted into a quasi-guided mode if the period p_y is set so as to satisfy the condition represented by the formula (16) (particularly, the condition represented by the formula (17)). As a result, the photoluminescent layer 110 can efficiently absorb excitation light having the wavelength λ_{ex} .

FIGS. 17C and 17D are the calculation results of the proportion of absorbed light to light incident on the structures shown in FIGS. 17A and 17B, respectively, for each wavelength. In these calculations, $p_x=365$ nm, $p_y=265$ nm, the photoluminescent layer 110 had an emission wavelength λ of about 600 nm, excitation light had a wavelength λ_{ex} of about 450 nm, and the photoluminescent layer 110 had an extinction coefficient of 0.003. FIG. 17D shows high absorptivity not only for light from the photoluminescent layer 110 but also for excitation light of approximately 450 nm. This indicates that incident light is effectively converted into a quasi-guided mode and thereby increases the proportion of light absorbed into the photoluminescent layer 110. The photoluminescent layer 110 also has high absorptivity for the emission wavelength, that is, approximately 600 nm. This indicates that light having a wavelength of approximately 600 nm incident on this structure is similarly effectively converted into a quasi-guided mode.

The surface structure 120 illustrated in FIG. 17B is a two-dimensional periodic structure including structures having different periods (different periodic components) in the x direction and the y direction. Such a two-dimensional periodic structure including multiple periodic components allows for high excitation efficiency and high output intensity. Although excitation light is incident on the transparent substrate 140 in FIGS. 17A and 17B, the same effect can be achieved if excitation light is incident on the surface structure 120.

Also available are two-dimensional periodic structures including periodic components as illustrated in FIGS. 18A and 18B. The structure illustrated in FIG. 18A includes periodically arranged projections or recesses having a hexagonal planar shape. The structure illustrated in FIG. 18B includes periodically arranged projections or recesses having a triangular planar shape. These structures have major axes (axes 1 to 3 in these examples) that can be assumed to be periodic. Thus, the structures can have different periods in different axial directions. These periods may be set so as to increase the directionality of light beams of different wavelengths or to efficiently absorb excitation light. In any case, each period is set so as to satisfy the condition corresponding to the formula (10).

5-3. Periodic Structure on Transparent Substrate

As illustrated in FIGS. 19A and 19B, a surface structure 120a may be formed on the transparent substrate 140, and the photoluminescent layer 110 may be disposed thereon. In the example in FIG. 19A, the photoluminescent layer 110 is formed along the texture of the surface structure 120a on the transparent substrate 140. As a result, a surface structure 120b with the same period is formed in the surface of the photoluminescent layer 110. In the example in FIG. 19B, the surface of the photoluminescent layer 110 is flattened. In these examples, directional light emission can be achieved by setting the period p of the surface structure 120a so as to satisfy the formula (15).

25

To verify the effect of these structures, the enhancement of light emitted from the structure illustrated in FIG. 19A in the front direction was calculated with varying emission wavelengths and varying periods of the periodic structure. In these calculations, the photoluminescent layer 110 had a thickness of 1,000 nm and a refractive index n_{wav} of 1.8, the surface structure 120a was a one-dimensional periodic structure uniform in the y direction and had a height of 50 nm, a refractive index n_p of 1.5, and a period of 400 nm, and the polarization of light was in the TM mode, which has an electric field component parallel to the y direction. FIG. 19C shows the calculation results. Also in these calculations, light intensity peaks were observed at the periods that satisfy the condition represented by the formula (15).

5-4. Powder

These embodiments show that light having any wavelength can be enhanced by adjusting the period of the periodic structure and/or the thickness of the photoluminescent layer. For example, if the structure illustrated in FIGS. 1A and 1B is formed using a photoluminescent material that emits light over a wide wavelength range, only light having a certain wavelength can be enhanced. The structure of the light-emitting device 100 as illustrated in FIGS. 1A and 1B may be provided in powder form for use as a fluorescent material. Alternatively, the light-emitting device 100 as illustrated in FIGS. 1A and 1B may be embedded in resin or glass.

The single structure as illustrated in FIGS. 1A and 1B can emit only light having a certain wavelength in a particular direction and is therefore not suitable for light having a wide wavelength spectrum, such as white light. Accordingly, as shown in FIG. 20, light-emitting devices 100 that differ in, for example, the period of the periodic structure or the thickness of the photoluminescent layer, may be mixed in powder form to provide a light-emitting apparatus with a wide wavelength spectrum. In such a case, the individual light-emitting devices 100 have sizes of, for example, several micrometers to several millimeters in one direction and can include, for example, one- or two-dimensional periodic structures with several periods to several hundreds of periods.

5-5. Array of Structures with Different Periods

FIG. 21 is a plan view of a two-dimensional array of periodic structures having different periods on a photoluminescent layer. In a light-emitting device 100c illustrated in FIG. 21, three types of surface structures 120a, 120b, and 120c are arranged without any space therebetween. The periods of the surface structures 120a, 120b, and 120c are set to emit, for example, light in the red, green, and blue wavelength ranges, respectively, in the front direction. Such structures having different periods can be arranged on the photoluminescent layer to emit directional light having a wide wavelength spectrum. The periodic structures are not necessarily formed as described above, but may be formed in any manner.

5-6. Layered Structure

FIG. 22 illustrates a light-emitting device including photoluminescent layers 110 each having a textured surface. A transparent substrate 140 is disposed between the photoluminescent layers 110. The texture on each of the photoluminescent layers 110 corresponds to the periodic structure or the submicron structure. The example in FIG. 22 includes three periodic structures having different periods. The periods of these periodic structures are set to emit light in the red, green, and blue wavelength ranges in the front direction. The photoluminescent layer 110 in each layer is formed of a material that emits light having the color corresponding to

26

the period of the periodic structure in that layer. Thus, periodic structures having different periods can be stacked on top of each other to emit directional light having a wide wavelength spectrum.

The number of layers and the constructions of the photoluminescent layer 110 and the periodic structure in each layer are not limited to those described above, but may be selected as appropriate. For example, for a structure including two layers, first and second photoluminescent layers are formed opposite each other with a light-transmissive substrate therebetween, and first and second periodic structures are formed on the surfaces of the first and second photoluminescent layers, respectively. In such a case, the first photoluminescent layer and the first periodic structure satisfy the condition represented by the formula (15), and the second photoluminescent layer and the second periodic structure satisfy the condition represented by the formula (15). For a structure including three or more layers, the photoluminescent layer and the periodic structure in each layer satisfy the condition represented by the formula (15). The positional relationship between the photoluminescent layers and the periodic structures in FIG. 22 may be reversed. Although the layers have different periods in FIG. 22, all the layers may have the same period. In such a case, although the spectrum cannot be broadened, the emission intensity can be increased.

5-7. Structure Including Protective Layer

FIG. 23 is a cross-sectional view of a structure including a protective layer 150 between the photoluminescent layer 110 and the surface structure 120. The protective layer 150 may be provided to protect the photoluminescent layer 110. However, if the protective layer 150 has a lower refractive index than the photoluminescent layer 110, the electric field of light leaks into the protective layer 150 only by about half the wavelength. Thus, if the protective layer 150 has a thickness greater than the wavelength, no light reaches the surface structure 120. As a result, there is no quasi-guided mode, and the function of emitting light in a particular direction cannot be achieved. If the protective layer 150 has a refractive index higher than or similar to that of the photoluminescent layer 110, light reaches the interior of the protective layer 150; therefore, there is no limitation on the thickness of the protective layer 150. Nevertheless, a thinner protective layer 150 is advantageous because more light is emitted if most of the portion in which light is guided (this portion is hereinafter referred to as a "waveguide layer") is formed of a photoluminescent material. The protective layer 150 may be formed of the same material as the surface structure (or light-transmissive layer) 120. In such a case, the light-transmissive layer 120 having the periodic structure also functions as a protective layer. The light-transmissive layer 120 advantageously has a lower refractive index than the photoluminescent layer 110.

6. Materials

Directional light emission can be achieved if the photoluminescent layer (or waveguide layer) and the surface structure are formed of materials that satisfy the above conditions. The surface structure may be formed of any material. However, a photoluminescent layer (or waveguide layer) or a surface structure formed of a medium with high light absorption is less effective in confining light and therefore results in a lower peak intensity and Q value. Thus, the photoluminescent layer (or waveguide layer) and the surface structure may be formed of a material with relatively low light absorption.

For example, the surface structure may be formed of a dielectric material having low light absorptivity. Examples of candidate materials for the periodic structure include magnesium fluoride (MgF_2), lithium fluoride (LiF), calcium fluoride (CaF_2), quartz (SiO_2), glasses, resins, magnesium oxide (MgO), indium tin oxide (ITO), titanium oxide (TiO_2), silicon nitride (SiN), tantalum pentoxide (Ta_2O_5), zirconia (ZrO_2), zinc selenide (ZnSe), and zinc sulfide (ZnS). To form a surface structure having a lower refractive index than the photoluminescent layer, as described above, MgF_2 , LiF, CaF_2 , SiO_2 , glasses, and resins can be used, which have refractive indices of approximately 1.3 to 1.5.

The term "photoluminescent material" encompasses fluorescent materials and phosphorescent materials in a narrow sense, encompasses inorganic materials and organic materials (for example, dyes), and encompasses quantum dots (for example, tiny semiconductor particles). In general, fluorescent materials containing an inorganic host material tend to have a higher refractive index. Examples of fluorescent materials that emit blue light include $\text{M}_{10}(\text{PO}_4)_6\text{Cl}_2:\text{Eu}^{2+}$ (wherein M is at least one element selected from Ba, Sr, and Ca), $\text{BaMgAl}_{10}\text{O}_{17}:\text{Eu}^{2+}$, $\text{M}_3\text{MgSi}_2\text{O}_8:\text{Eu}^{2+}$ (wherein M is at least one element selected from Ba, Sr, and Ca), and $\text{M}_5\text{SiO}_4\text{Cl}_6:\text{Eu}^{2+}$ (wherein M is at least one element selected from Ba, Sr, and Ca). Examples of fluorescent materials that emit green light include $\text{M}_2\text{MgSi}_2\text{O}_7:\text{Eu}^{2+}$ (wherein M is at least one element selected from Ba, Sr, and Ca), $\text{SrSi}_2\text{O}_2\text{N}_2:\text{Eu}^{2+}$, $\text{SrSi}_2\text{O}_2\text{N}_2:\text{Eu}^{2+}$, $\text{BaAl}_2\text{O}_4:\text{Eu}^{2+}$, $\text{BaZrSi}_3\text{O}_9:\text{Eu}^{2+}$, $\text{M}_2\text{SiO}_4:\text{Eu}^{2+}$ (wherein M is at least one element selected from Ba, Sr, and Ca), $\text{BaSi}_3\text{O}_4\text{N}_2:\text{Eu}^{2+}$, $\text{CaMg}(\text{SiO}_4)_4\text{Cl}_2:\text{Eu}^{2+}$, $\text{Ca}_3\text{SiO}_4\text{Cl}_2:\text{Eu}^{2+}$, $\text{CaSi}_{12-(m+n)}\text{Al}_{(m+n)}\text{O}_n\text{N}_{16-n}:\text{Ce}^{3+}$, and $\beta\text{-SiAlON}:\text{Eu}^{2+}$. Examples of fluorescent materials that emit red light include $\text{CaAlSiN}_3:\text{Eu}^{2+}$, $\text{SrAlSi}_4\text{O}_7:\text{Eu}^{2+}$, $\text{M}_2\text{Si}_5\text{N}_8:\text{Eu}^{2+}$ (wherein M is at least one element selected from Ba, Sr, and Ca), $\text{MSiN}_2:\text{Eu}^{2+}$ (wherein M is at least one element selected from Ba, Sr, and Ca), $\text{MSi}_2\text{O}_2\text{N}_2:\text{Yb}^{2+}$ (wherein M is at least one element selected from Sr and Ca), $\text{Y}_2\text{O}_2\text{S}:\text{Eu}^{3+}$, Sm^{3+} , $\text{La}_2\text{O}_2\text{S}:\text{Eu}^{3+}$, Sm^{3+} , $\text{CaWO}_4:\text{Li}^{1+}$, Eu^{3+} , Sm^{3+} , $\text{M}_2\text{SiS}_4:\text{Eu}^{2+}$ (wherein M is at least one element selected from Ba, Sr, and Ca), and $\text{M}_3\text{SiO}_5:\text{Eu}^{2+}$ (wherein M is at least one element selected from Ba, Sr, and Ca). Examples of fluorescent materials that emit yellow light include $\text{Y}_3\text{Al}_5\text{O}_{12}:\text{Ce}^{3+}$, $\text{CaSi}_2\text{O}_2\text{N}_2:\text{Eu}^{2+}$, $\text{Ca}_3\text{Sc}_2\text{Si}_3\text{O}_{12}:\text{Ce}^{3+}$, $\text{CaSc}_2\text{O}_4:\text{Ce}^{3+}$, $\alpha\text{-SiAlON}:\text{Eu}^{2+}$, $\text{MSi}_2\text{O}_2\text{N}_2:\text{Eu}^{2+}$ (wherein M is at least one element selected from Ba, Sr, and Ca), and $\text{M}_7(\text{SiO}_3)_6\text{Cl}_2:\text{Eu}^{2+}$ (wherein M is at least one element selected from Ba, Sr, and Ca).

Examples of quantum dots include materials such as CdS, CdSe, core-shell CdSe/ZnS, and alloy CdSSe/ZnS. Light having various wavelengths can be emitted depending on the material. Examples of matrices for quantum dots include glasses and resins.

The substrate **140**, as illustrated in, for example, FIGS. **1C** and **1D**, is formed of a light-transmissive material having a lower refractive index than the photoluminescent layer **110**. Examples of such materials include MgF_2 , LiF, CaF_2 , SiO_2 , glasses, and resins. In structures in which excitation light enters the photoluminescent layer **110** without passing through the substrate **140**, the substrate **140** is not necessarily transparent. For example, the substrate **140** may be formed of BaF_2 , SrF_2 , MgO , MgAl_2O_4 , sapphire (Al_2O_3), SrTiO_3 , LaAlO_3 , TiO_2 , $\text{Gd}_3\text{Ga}_5\text{O}_{12}$, LaSrAlO_4 , LaSrGaO_4 , LaTaO_3 , SrO, yttria-stabilized zirconia (YSZ) $\text{ZrO}_2\text{-Y}_2\text{O}_3$, yttrium-aluminum-garnet (YAG), or $\text{Tb}_3\text{Ga}_5\text{O}_{12}$.

7. Production Method

A method for producing a light-emitting device will be described below.

A method for forming the structure illustrated in FIGS. **1C** and **1D** includes forming a thin film of the photoluminescent layer **110** on the transparent substrate **140**, for example, by evaporation, sputtering, or coating of a fluorescent material, forming a dielectric film, and then patterning the dielectric film, for example, by photolithography to form the surface structure **120**. Alternatively, the surface structure **120** may be formed by nanoimprinting. As illustrated in FIG. **24**, the surface structure **120** may also be formed by partially processing the photoluminescent layer **110**. In such a case, the surface structure **120** is formed of the same material as the photoluminescent layer **110**.

The light-emitting device **100** illustrated in FIGS. **1A** and **1B** can be produced, for example, by producing the light-emitting device **100a** illustrated in FIGS. **1C** and **1D** and then removing the photoluminescent layer **110** and the surface structure **120** from the substrate **140**.

The structure illustrated in FIG. **19A** can be produced, for example, by forming the surface structure **120a** on the transparent substrate **140** by a process such as a semiconductor process or nanoimprinting and then depositing thereon the material of the photoluminescent layer **110** by a process such as evaporation or sputtering. The structure illustrated in FIG. **19B** can also be formed by filling the recesses in the surface structure **120a** with the photoluminescent layer **110** by coating.

These production methods are for illustrative purposes only, and the light-emitting devices according to the embodiments of the present disclosure may be produced by other methods.

8. Experimental Examples

Light-emitting devices for use in light-emitting apparatuses according to embodiments of the present disclosure are described in the following examples.

A sample light-emitting device having the structure as illustrated in FIG. **19A** was prepared and evaluated for its properties. The light-emitting device was prepared as described below.

A one-dimensional periodic structure (stripe-shaped projections) having a period of 400 nm and a height of 40 nm was formed on a glass substrate, and a photoluminescent material YAG:Ce was deposited thereon to form a film having a thickness of 210 nm. FIG. **25** shows a cross-sectional transmission electron microscopy (TEM) image of the resulting light-emitting device. FIG. **26** shows the measurement results of the spectrum of light emitted from the light-emitting device in the front direction when YAG:Ce was excited with an LED having an emission wavelength of 450 nm. FIG. **26** shows the results (ref) for a light-emitting device having no periodic structure, the results for the TM mode, and the results for the TE mode. The TM mode has a polarization component parallel to the one-dimensional periodic structure. The TE mode has a polarization component perpendicular to the one-dimensional periodic structure. The results show that the intensity of light having a particular wavelength is significantly higher in the presence of the periodic structure than in the absence of the periodic structure. The results also show that the light enhancement effect is greater in the TM mode, which has a polarization component parallel to the one-dimensional periodic structure.

FIGS. **27A** to **27F** and FIGS. **28A** to **28F** show the results of measurements and calculations of the angular dependence of the intensity of light emitted from the same sample. FIG. **27A** illustrates a light-emitting device that can emit linearly

polarized light in the TM mode, rotated about an axis parallel to the line direction of the one-dimensional periodic structure **120**. FIGS. **27B** and **27C** show the results of measurements and calculations for the rotation. FIG. **27D** illustrates a light-emitting device that can emit linearly polarized light in the TE mode, rotated about an axis parallel to the line direction of the one-dimensional periodic structure **120**. FIGS. **27E** and **27F** show the results of measurements and calculations for the rotation. FIG. **28A** illustrates a light-emitting device that can emit linearly polarized light in the TE mode, rotated about an axis perpendicular to the line direction of the one-dimensional periodic structure **120**. FIGS. **28B** and **28C** show the results of measurements and calculations for the rotation. FIG. **28D** illustrates a light-emitting device that can emit linearly polarized light in the TM mode, rotated about an axis perpendicular to the line direction of the one-dimensional periodic structure **120**. FIGS. **28E** and **28F** show the results of measurements and calculations for the rotation.

As is clear from FIGS. **27A** to **27F** and FIGS. **28A** to **28F**, the enhancement effect is greater for the TM mode. The wavelength of enhanced light shifts with angle. For example, light having a wavelength of 610 nm is observed only in the TM mode and in the front direction, indicating that the light is directional and polarized. Furthermore, the measurement results and the calculation results match each other in FIGS. **27B** and **27C**, FIGS. **27E** and **27F**, FIGS. **28B** and **28C**, and FIGS. **28E** and **28F**. Thus, the validity of the above calculations was experimentally demonstrated.

FIG. **29** shows the angular dependence of the intensity of light having a wavelength of 610 nm for rotation about an axis perpendicular to the line direction, as illustrated in FIG. **28D**. The results show that the light was significantly enhanced in the front direction and was little enhanced at other angles. The directional angle of light emitted in the front direction is less than 15 degrees. As described above, the directional angle is the angle at which the intensity is 50% of the maximum intensity and is expressed as the angle of one side with respect to the direction with the maximum intensity. The results shown in FIG. **29** demonstrates that directional light emission was achieved. In addition, all the light was in the TM mode, which demonstrates that polarized light emission was simultaneously achieved.

Although YAG:Ce, which emits light in a wide wavelength range, was used in the above experiment, directional and polarized light emission can also be achieved using a similar structure including a photoluminescent material that emits light in a narrow wavelength range. Such a photoluminescent material does not emit light having other wavelengths and can therefore be used to provide a light source that does not emit light in other directions or in other polarized states.

9. Other Modifications

As described above, the wavelength and emission direction of light under the light enhancement effect depend on the submicron structure of a light-emitting device according to the present disclosure. FIG. **31** illustrates a light-emitting device having a surface structure **120** on a photoluminescent layer **110**. The surface structure **120** is formed of the same material as the photoluminescent layer **110** and has the one-dimensional periodic structure illustrated in FIG. **1A**. Light to be enhanced by the one-dimensional periodic structure satisfies $p \times n_{wav} \times \sin \theta_{wav} = p \times n_{out} \times \sin \theta_{out} = m\lambda$ (see the formula (5)), wherein p (nm) denotes the period of the one-dimensional periodic structure, n_{wav} denotes the refrac-

tive index of the photoluminescent layer **110**, n_{out} denotes the refractive index of an outer medium to which the light is emitted, θ_{wav} denotes the incident angle on the one-dimensional periodic structure, and θ_{out} denotes the angle at which the light is emitted from one-dimensional periodic structure to the outer medium. λ is the light wavelength in air, and m is an integer.

The formula can be transformed into $\theta_{out} = \arcsin [(n_{wav} \times \sin \theta_{wav} - m\lambda/p)/n_{out}]$. Thus, in general, the output angle θ_{out} of light under the light enhancement effect varies with the wavelength λ . Consequently, as schematically illustrated in FIG. **31**, the color of visible light varies with the observation direction.

This visual angle dependency can be reduced by determining n_{wav} and n_{out} so as to make $(n_{wav} \times \sin \theta_{wav} - m\lambda/p)/n_{out}$ constant for any wavelength λ . The refractive indices of substances have wavelength dispersion (wavelength dependence). Thus, a material to be selected should have the wavelength dispersion characteristics of n_{wav} and n_{out} such that $(n_{wav} \times \sin \theta_{wav} - m\lambda/p)/n_{out}$ is independent of the wavelength λ . For example, if the outer medium is air, n_{out} is approximately 1.0 irrespective of the wavelength. Thus, the material of the photoluminescent layer **110** and the one-dimensional periodic structure has a narrow wavelength dispersion of the refractive index n_{wav} . The material may have reciprocal dispersion, in which the refractive index n_{wav} decreases with decreasing wavelength of light.

As illustrated in FIG. **32A**, an array of periodic structures having different wavelengths at which the light enhancement effect is produced can emit white light. In the example illustrated in FIG. **32A**, a surface structure **120r** that can enhance red light (R), a surface structure **120g** that can enhance green light (G), and a surface structure **120b** that can enhance blue light (B) are arranged in a matrix. Each of the surface structures **120r**, **120g**, and **120b** may be a one-dimensional periodic structure. The projections of the surface structures **120r**, **120g**, and **120b** are arranged in parallel. Thus, the red light, green light, and blue light have the same polarization characteristics. Light beams of three primary colors emitted from the surface structures **120r**, **120g**, and **120b** under the light enhancement effect are mixed to produce linearly polarized white light.

Each of the surface structures **120r**, **120g**, and **120b** arranged in a matrix is referred to as a unit periodic structure (or pixel). The size (the length of one side) of the unit periodic structure may be at least three times the period. The unit periodic structures are advantageously not perceived by the human eye in order to produce the color mixing effect. For example, the length of one side is less than 1 mm. Although each of the unit periodic structures is square in FIG. **32A**, adjacent surface structures **120r**, **120g**, and **120b** may be in the shape other than square, such as rectangular, triangular, or hexagonal.

A photoluminescent layer under each of the surface structures **120r**, **120g**, and **120b** may be the same or may be formed of different photoluminescent materials corresponding to each color of light.

As illustrated in FIG. **32B**, the projections of the one-dimensional periodic structures (including surface structures **120h**, **120i**, and **120j**) may extend in different directions. Light emitted from each of the periodic structures under the light enhancement effect may have the same wavelength or different wavelengths. For example, the same periodic structures arranged as illustrated in FIG. **32B** can produce unpolarized light. The surface structures **120r**, **120g**, and **120b** in FIG. **32A** arranged as illustrated in FIG. **32B** can produce unpolarized white light as a whole.

As a matter of course, the periodic structures to be tiled are not limited to one-dimensional periodic structures and may be two-dimensional periodic structures (including surface structures **120k**, **120m**, and **120n**), as illustrated in FIG. **32C**. The period and direction of each of the surface structures **120k**, **120m**, and **120n** may be the same or different, as described above, and may be appropriately determined as required.

As illustrated in FIG. **33**, for example, an array of microlenses **130** may be disposed on a light emission side of a light-emitting device. The array of microlenses **130** can refract oblique light in the normal direction and thereby produce the color mixing effect.

The light-emitting device illustrated in FIG. **33** includes regions **R1**, **R2**, and **R3**, which include the surface structures **120r**, **120g**, and **120b**, respectively, illustrated in FIG. **32A**. In the region **R1**, the surface structure **120r** emits red light **R** in the normal direction and, for example, emits green light **G** in an oblique direction. The microlens **130** refracts the oblique green light **G** in the normal direction. Consequently, a mixture of red light **R** and green light **G** is observed in the normal direction. Thus, the microlenses **130** can reduce difference in light wavelength depending on the angle. Although the microlens array including microlenses corresponding to the periodic structures is described here, another microlens array is also possible. As a matter of course, periodic structures to be tiled are not limited to those described above and may be the same periodic structures or the structures illustrated in FIG. **32B** or **32C**.

A lenticular lens may also be used as an optical element for refracting oblique light instead of the microlens array. In addition to lenses, prisms may also be used. A prism array may also be used. A prism corresponding to each periodic structure may be arranged. Prisms of any shape may be used. For example, triangular prisms or pyramidal prisms may be used.

White light (light having a broad spectral width) may be produced by using the periodic structure described above or using two or more photoluminescent layers as illustrated in FIG. **34A** or **34B**. As illustrated in FIG. **34A**, photoluminescent layers **110b**, **110g**, and **110r** having different emission wavelengths may be stacked to produce white light. The stacking sequence is not limited to that illustrated in FIG. **34A**. As illustrated in FIG. **34B**, a photoluminescent layer **110y** that emits yellow light may be disposed on a photoluminescent layer **110b** that emits blue light. The photoluminescent layer **110y** may be formed of YAG.

When photoluminescent materials, such as fluorescent dyes, to be mixed with a matrix (host) material are used, photoluminescent materials having different emission wavelengths may be mixed with the matrix material to emit white light from a single photoluminescent layer. Such a photoluminescent layer that can emit white light may be used in tiled unit periodic structures as illustrated in FIGS. **32A** to **32C**.

10. Light-Emitting Apparatus Including Converging Lens

An exemplary structure of a light-emitting apparatus according to an embodiment of the present disclosure will be described below. FIG. **35** is a schematic view of an exemplary structure of a light-emitting apparatus according to an embodiment of the present disclosure. A light-emitting apparatus **210A** illustrated in FIG. **35** roughly includes the light-emitting apparatus **200** illustrated in FIG. **16** and a converging lens **202** for receiving light from the light-

emitting apparatus **200**. More specifically, the light-emitting apparatus **210A** includes the excitation light source **180**, the light-emitting device **100**, and the converging lens **202**.

The light-emitting device **100** is disposed on the optical path of excitation light emitted from the excitation light source **180**. Excitation light emitted from the excitation light source **180** enters the photoluminescent layer **110** of the light-emitting device **100** disposed on the optical path of the excitation light. The photoluminescent material in the photoluminescent layer **110** emits light upon receiving excitation light. Light from the photoluminescent layer **110** is emitted from the light-emitting device **100** through the surface structure **120** (see FIG. **16**, for example). As described above, the light-emitting device **100** can emit light in a particular direction. In this example, light is emitted in the front direction of the light-emitting device **100**. As a matter of course, the light-emitting device **100a** illustrated in FIGS. **1C** and **1D** may be used instead of the light-emitting device **100**.

Light emitted from the light-emitting device **100** enters the converging lens **202** facing the surface structure **120**. In the structure illustrated in FIG. **35**, the converging lens **202** is supported by a housing **300** so as to be disposed on the optical path of light emitted from the light-emitting device **100**. The housing **300** may fix the positions of the light-emitting device **100** and the converging lens **202**.

In the structure illustrated in FIG. **35**, the light-emitting apparatus **210A** is coupled to an optical fiber **250**. In this example, the housing **300** has an opening **300a** at an incident position of light passing through the converging lens **202**. One end of the optical fiber **250** is inserted into the opening **300a** and is fixed to the light-emitting apparatus **210A**.

One end of the optical fiber **250** coupled to the light-emitting apparatus **210A** is disposed at an incident position of light passing through the converging lens **202**. Thus, at least part of light passing through the converging lens **202** enters the optical fiber **250**. Thus, the optical fiber **250** coupled to the light-emitting apparatus **210A** is optically coupled to the light-emitting apparatus **210A**. Thus, in the structure illustrated in FIG. **35**, the opening **300a** functions as a joint for the optical fiber **250**. In this example, the optical axis of the converging lens **202** coincides with the axis of the optical fiber **250**.

A structure for coupling of an optical fiber may be any structure that can receive an inlet of the optical fiber and is not limited to the structure illustrated in FIG. **35**. The opening **300a** may be provided with a transparent member that can transmit light passing through the converging lens **202**. A transparent member on the opening **300a** may have an antireflection coating. The light-emitting apparatus **210A** may have an optical connector, socket, slot, or plug as a joint for an optical fiber at the incident position of light passing through the converging lens **202**.

As described above, the light-emitting device **100** has a novel structure for controlling the directionality of emitted light. For example, the light-emitting device **100** can selectively emit light from the photoluminescent layer **110** in the front direction. Thus, as schematically illustrated in FIG. **36**, the outgoing beams can almost entirely enter the converging lens **202** without a collimating lens. Since the light-emitting device **100** can emit directional light, the present embodiment of the present disclosure can improve light-use efficiency without a large converging lens. Thus, a smaller light-emitting apparatus or optical device can be provided.

FIG. **37** illustrates a light-emitting apparatus **510** according to a comparative example. The light-emitting apparatus **510** includes a known phosphor **512** instead of the light-

emitting device **100**. In FIGS. **36** and **37**, the housing **300** illustrated in FIG. **35** is omitted. The housing **300** may also be omitted in other figures.

In the light-emitting apparatus **510**, the phosphor **512** emits light in all directions. Thus, the outgoing beams from the phosphor **512** include light beams that cannot theoretically enter the converging lens **202**. Thus, light from the phosphor **512** cannot be effectively utilized. For example, as schematically illustrated in FIG. **37**, the percentage of light beams emitted from the phosphor **512** and incident on the converging lens **202** is approximately 20%. The remainder (80%) of the light beams emitted from the phosphor **512** are lost.

In the optical system illustrated in FIG. **36** or **37** in which light emitted from the light source (the light-emitting device **100** or the phosphor **512**) enters the optical fiber **250**, it is known that the amount called "etendue" is preserved in the absence of diffusion. For example, the etendue of a light source is defined as the product of the luminous area of the light source and the solid angle of divergent light from the light source. Etendue is also defined for a surface for receiving light from the light source. The etendue on a light-receiving side represents the ability of introducing light. When the etendue on a light-receiving side is smaller than the etendue of a light source, light from the light source is not entirely introduced into the light-receiving side and is partly lost. When the etendue of a light source is identical with the etendue of an optical fiber to be irradiated, the light-use efficiency reaches its maximum. The etendue of the optical fiber **250** depends on the numerical aperture of the optical fiber **250**. An etendue of the light source greater than the etendue of the optical fiber causes a loss.

In the light-emitting apparatus **210A** illustrated in FIG. **36**, when the converging lens **202** has a focal length that matches the numerical aperture of the optical fiber **250**, and the distance between the converging lens **202** and an end surface of the optical fiber **250** is appropriate, light from the converging lens **202** can almost entirely enter the optical fiber **250**. If the light-emitting apparatus **210A** has a joint for an optical fiber, the optical fiber **250** can be fixed to the light-emitting apparatus **210A**, and the light-emitting apparatus **210A** and the optical fiber **250** can advantageously have high coupling efficiency.

In contrast, in the structure that includes the known phosphor **512** instead of the light-emitting device **100** (see FIG. **37**), the phosphor **512** emits light in all directions, and the etendue of the phosphor **512** is generally greater than the etendue of the optical fiber. Thus, the phosphor **512** and the optical fiber **250** cannot have high coupling efficiency. In the structure illustrated in FIG. **37**, the phosphor **512** and the optical fiber **250** have a coupling efficiency of only 20%. As long as the etendue on a light-receiving side is constant, the amount of light incident on the optical fiber **250** does not increase with increasing luminous area of the light source (the phosphor **512**). As described above, the etendue of the optical fiber **250** depends on the numerical aperture of the optical fiber **250**. Thus, if the numerical aperture of the optical fiber **250** is constant, an increase in the diameter of the converging lens **202** to increase the number of light beams incident on the converging lens **202** cannot increase the number of light beams incident on the optical fiber **250**.

In the light-emitting apparatus **210A**, outgoing beams from the light-emitting device **100** can almost entirely enter the converging lens **202** (see FIG. **36**). Light from the light-emitting device **100** can almost entirely enter the optical fiber **250**. Thus, in the present embodiment of the present disclosure, the emission direction of light from the

light-emitting device **100** can be controlled through the converging lens **202** such that the light enters the optical fiber **250**. This can improve coupling efficiency between the light-emitting device **100** and the optical fiber **250**.

In the present embodiment of the present disclosure, the same output (light beam) from the optical fiber **250** can be produced with smaller input energy due to higher coupling efficiency between the light-emitting device **100** and the optical fiber **250**. For example, if the optical fiber **250** produces an output of 2.3 W using a laser diode having a power conversion efficiency of 40% as the excitation light source **180**, and the phosphor has a conversion efficiency of 55%, then energy input to the excitation light source **180** per unit time is approximately 53.9 W in the light-emitting apparatus **510** according to the comparative example illustrated in FIG. **37** and approximately 10.7 W in the light-emitting apparatus **210A** illustrated in FIG. **36**. Thus, the light-emitting apparatus **210A** can save energy.

In FIGS. **35** to **37**, the converging lens **202** is a biconvex lens. However, the converging lens **202** is not limited to the biconvex lens and may be a plano-convex lens, a Fresnel lens, or a gradient refractive index lens (GRIN) lens, in which the refractive index changes along an axis. The converging lens **202** may be a lens attached to an end surface of the optical fiber.

10-1. Modified Examples of Light-Emitting Apparatus Including Converging Lens

FIG. **38** illustrates another modified example of a light-emitting apparatus according to an embodiment of the present disclosure; A light-emitting apparatus **210B** illustrated in FIG. **38** includes a collimating lens **204** between the light-emitting device **100** and the converging lens **202**. Light emitted from the light-emitting device **100** has a relatively small directional angle. Thus, high light-use efficiency can be achieved even with the collimating lens **204** having a small diameter. In this structure, the distance between the light-emitting device **100** and a joint of the optical fiber **250** can be increased. This improves the design flexibility of the optical system.

FIG. **39** illustrates still another modified example of a light-emitting apparatus according to an embodiment of the present disclosure. A light-emitting apparatus **210C** illustrated in FIG. **39** includes a collimating lens **208** between the excitation light source **180** and the light-emitting device **100**. In this structure, the light-emitting device **100** can be irradiated with collimated excitation light. Thus, the photoluminescent layer **110** can be evenly excited.

FIG. **40** illustrates still another modified example of a light-emitting apparatus according to an embodiment of the present disclosure. A light-emitting apparatus **210D** illustrated in FIG. **40** includes the collimating lens **208** between the excitation light source **180** and the light-emitting device **100** and a converging lens **206** between the collimating lens **208** and the light-emitting device **100**. This structure can converge excitation light and therefore miniaturize the light-emitting device **100**. Thus, the optical system can be miniaturized. Furthermore, the distance between the excitation light source **180** and the light-emitting device **100** can be increased. This improves the design flexibility of the optical system.

FIG. **41** illustrates still another modified example of a light-emitting apparatus according to an embodiment of the present disclosure. As in the light-emitting apparatus **210B** illustrated in FIG. **38**, a light-emitting apparatus **210E** illustrated in FIG. **41** includes the collimating lens **204** between the light-emitting device **100** and the converging lens **202**. As in the light-emitting apparatus **210D** illustrated in FIG.

40, the light-emitting apparatus 210E further includes the collimating lens 208 and the converging lens 206 between the excitation light source 180 and the light-emitting device 100. As illustrated in FIG. 41, the collimating lens 208 and the converging lens 206 are disposed in this order from the excitation light source 180 to the light-emitting device 100. As illustrated in FIG. 41, a collimating lens and a converging lens may be disposed between the excitation light source 180 and the light-emitting device 100 and between the light-emitting device 100 and an optical component (the optical fiber 250) that receives light from the light-emitting apparatus. Thus, the light-emitting apparatus 210E has the same advantages as the light-emitting apparatus 210B illustrated in FIG. 38 and the light-emitting apparatus 210D illustrated in FIG. 40.

As described above, an optical system in a light-emitting apparatus according to the present disclosure can be variously designed. In addition to the structures illustrated in FIGS. 38 to 41, for example, the collimating lens 208 can be removed from the light-emitting apparatus 210D illustrated in FIG. 40 or the light-emitting apparatus 210E illustrated in FIG. 41. In other words, there may be no collimating lens between the excitation light source 180 and the light-emitting device 100. In FIGS. 35 to 41, each of the converging lenses (the converging lenses 202 and 206) is a biconvex lens. However, this is for convenience of explanation. A converging lens in a light-emitting apparatus according to the present disclosure may be a combination of lenses. The same is true for the collimating lenses (the collimating lenses 204 and 208). As a matter of course, the collimating lenses (the collimating lenses 204 and 208) are not limited to biconvex lenses.

As described above, light-emitting devices and light-emitting apparatuses including the light-emitting devices according to the present disclosure have various advantages and can be used with advantageous effects in various optical devices. For example, the following applications are practicable.

A light-emitting device according to the present disclosure can emit directional light in a particular direction. Such high directionality can be suitably utilized in edge-light backlight units that include a light guide plate of a liquid crystal display unit. For example, when a known light source having low directionality is used, light from the light source is directed to a light guide plate through a reflector and/or a diffuser. When a light source having high directionality in a particular direction is used, light can be efficiently directed to a light guide plate without these optical components.

When a plurality of the light-emitting apparatuses 210A illustrated in FIG. 35 are used, and the output end surfaces of the optical fibers 250 optically coupled to the light-emitting apparatuses 210A are two-dimensionally arranged, the light-emitting apparatuses 210A can function as a display apparatus. Any of the light-emitting apparatuses 210B to 210E illustrated in FIGS. 38 to 41 may be used instead of the light-emitting apparatus 210A.

Known lighting fixtures include an optical component, including a reflector, to direct isotropic light in a desired direction. In contrast, in an embodiment of the present disclosure, a light-emitting device and an optical fiber can be optically coupled with high coupling efficiency. Thus, reflectors can be omitted. The use of a light-emitting device according to the present disclosure allows for a simple design for directional light instead of a complex design for isotropic light. Consequently, lighting fixtures can be reduced in size, or the process of designing lighting fixtures can be simplified.

A light-emitting device according to the present disclosure can enhance light having a particular wavelength alone. Thus, a light source that emits light having a required wavelength alone can be easily provided. The wavelength of emitted light can be adjusted by changing the periodic structure without changing the material of the photoluminescent layer. Furthermore, the wavelength of emitted light can be changed with the angle relative to the periodic structure. Such wavelength selectivity can be suitable for a narrow-band imaging (NBI, registered trademark) technique, for example. A light-emitting device according to the present disclosure can also be used for visible light communication.

In the field of illumination, color-enhancing light color illumination and beautifying light color illumination techniques have been developed. Such illumination can finely produce the color of an object to be illuminated. The color-enhancing light color illumination is effective in making foods, such as vegetables, look more delicious. The beautifying light color illumination is effective in ensuring natural-looking skin tones. Such illumination is performed by controlling the spectrum of the light source (the intensity distribution as a function of light wavelength) depending on the object. Hitherto, the spectrum of illumination light has been controlled by selective transmission of light emitted from a light source using an optical filter. The optical filter absorbs unnecessary light and consequently decreases light-use efficiency. In contrast, a light-emitting device according to the present disclosure can enhance light having a particular wavelength and requires no optical filter, thus improving light-use efficiency.

A light-emitting device according to the present disclosure can emit polarized light (linearly polarized light). When unpolarized light including two linearly polarized light components intersecting at right angles is emitted from a light source, linearly polarized light has hitherto been produced by absorbing one of the two linearly polarized light components using a polarizing filter (also referred to as a "polarizer"). Thus, the light-use efficiency is 50% or less. The use of a light-emitting device according to the present disclosure as a polarized light source can obviate the need for a polarizing filter and improve light-use efficiency. Polarized illumination is used to reduce reflected light, for example, from windowpanes of shop windows and view restaurants. Polarized illumination can also be used as washstand illumination, which utilizes the dependence of the reflection characteristics of the skin surface on polarized light, and is used to facilitate the observation of lesion sites with an endoscope.

A polarized light source is suitably used as a backlight for liquid crystal display units and as a light source for liquid crystal projectors. When a light-emitting device according to the present disclosure is used as a light source for liquid crystal projectors, in combination with the use of the wavelength selectivity, the light-emitting device can constitute a three-primary-color polarized light source. For example, a light-emitting device that emits red linearly polarized light, a light-emitting device that emits green linearly polarized light, and a light-emitting device that emits blue linearly polarized light may be joined together to form a disk. While the disk is irradiated with excitation light, the disk may be rotated to form a light source that successively emits red, green, and blue three-primary-color polarized light beams.

Application examples of a light-emitting device according to the present disclosure are not limited to those described above. A light-emitting device according to the present disclosure can be applied to various optical devices.

For example, as described below, a light-emitting device according to the present disclosure can be used to provide a small projector.

11. Projector

An exemplary structure of a projector that includes a light-emitting device according to the present disclosure will be described below. A projector according to an embodiment of the present disclosure includes a light source unit, an image-forming unit including a light modulator, and an optical fiber that introduces light from the light source unit at one end thereof and guides the light to the image-forming unit. In other words, the light source unit and the image-forming unit are coupled together via the optical fiber. As described in detail below, the light modulator changes the traveling direction of light emitted from the optical fiber in accordance with the image signal, thereby forming an image on a projection target, such as a screen or wall.

In an embodiment of the present disclosure, the light source unit includes an excitation light source, a photoluminescent layer for emitting light having a wavelength λ_e in air upon receiving excitation light from the excitation light source, a light-transmissive layer located on or near the photoluminescent layer, and a surface structure formed on a surface of at least one of the photoluminescent layer and the light-transmissive layer and having projections or recesses or both. The photoluminescent layer, light-transmissive layer, and surface structure can have the structure as described above. Directional light from the photoluminescent layer can be emitted in a particular direction without an optical component (or with a small optical component), such as a reflector or lens. Thus, a projector having a much smaller size than before can be provided.

Light directed from the light source unit to the image-forming unit via the optical fiber may be excitation light emitted from the excitation light source. In another embodiment of the present disclosure, the photoluminescent layer, the light-transmissive layer, and the surface structure are disposed in the image-forming unit. In this case, the light modulator receives light having a wavelength λ_e in air from the photoluminescent layer.

11-1. Projector Including Excitation Light Source in Light Source Unit

FIG. 42 is an outside drawing of a projector according to an embodiment of the present disclosure. In the structure illustrated in FIG. 42, a projector 2300 includes a main body unit 2350 and a lighting unit 2310. The main body unit 2350 may be attachable to a ceiling. The projector 2300 includes an optical fiber 2250 between the main body unit 2350 and the lighting unit 2310. In the projector 2300, light generated in the main body unit 2350 is transmitted to the lighting unit 2310 via the optical fiber 2250.

The lighting unit 2310 irradiates a screen or wall with light to form an image (motion picture or still picture). In the structure illustrated in FIG. 42, the lighting unit 2310 has an opening 2330. Light for forming an image is emitted from the lighting unit 2310 through the opening 2330. The lighting unit 2310 is coupled to the main body unit 2350 with a joint, such as a hinge, and can change the emission direction of light.

FIG. 43 illustrates an optical system of the projector 2300 illustrated in FIG. 42. The optical system of the projector 2300 roughly includes a light source unit 2360A, an image-forming unit 2320A, and the optical fiber 2250, which optically couples the light source unit 2360A with the image-forming unit 2320A. The light source unit 2360A and

the image-forming unit 2320A are disposed in the main body unit 2350 and the lighting unit 2310, respectively.

In the structure illustrated in FIG. 43, the light source unit 2360A includes the excitation light source 180 and a disk-shaped light-emitting device 100w. The light-emitting device 100w includes regions along its circumference. Each of the regions has the structure of the light-emitting device 100 or 100a. More specifically, each of the regions in the light-emitting device 100w includes the photoluminescent layer and the surface structure. In this example, as schematically illustrated in FIG. 43, each of the regions in the light-emitting device 100w has the structure of the light-emitting device illustrated in FIG. 19A. Although the light-emitting device 100a including the photoluminescent layer 110 on the substrate 140 (transparent substrate) is described below, the light-emitting device 100 may be used instead of the light-emitting device 100a.

The light-emitting device 100w is disposed on the optical path of excitation light emitted from the excitation light source 180. The excitation light source 180 may be an LED or laser diode. In this example, the light-emitting device 100w is disposed in the main body unit 2350 such that the substrate 140 faces the excitation light source 180. Excitation light emitted from the excitation light source 180 enters the photoluminescent layer 110 of the light-emitting device 100w through the substrate 140. As described above, the surface structure (periodic structure 120a and/or 120b) of the light-emitting device 100w functions to limit the directional angle of particular light emitted from the photoluminescent layer 110. Thus, the light-emitting device 100w emits intense light having a particular wavelength in a particular direction (for example, in the front direction).

The light-emitting device 100w is rotatably supported in the lighting unit 2310 and is rotated by a driving unit (for example, a motor, not shown in FIG. 43) during the operation of the projector 2300. Excitation light emitted from the excitation light source 180 enters at least one of the regions in the light-emitting device 100w depending on the rotation angle of the light-emitting device 100w.

Typically, the regions in the light-emitting device 100w have different periodic structures. In other words, the different regions in the light-emitting device 100w emit intense light beams of different wavelengths in a particular direction. Thus, the light-emitting device 100w emits light having a different wavelength depending on the region(s) that excitation light enters. The light-emitting device 100w may be referred to as a directional-light-emitting color wheel.

One end of the optical fiber 2250 is disposed on the optical path of light emitted from the light-emitting device 100w. One end of the optical fiber 2250 on the optical path of light emitted from the light-emitting device 100w is optically coupled to the light-emitting device 100w. As described above, a light-emitting device according to the present disclosure has a novel structure for controlling the directionality of emitted light. Thus, the light-emitting device 100w and the optical fiber 2250 can have high coupling efficiency. A converging lens may be disposed between the optical fiber 2250 and the light-emitting device 100w.

The optical fiber 2250 transmits light from the light source unit 2360A of the main body unit 2350 to the lighting unit 2310 (see FIG. 42). Thus, light generated in the light source unit 2360A is transmitted to the image-forming unit 2320A in the lighting unit 2310 via the optical fiber 2250.

The image-forming unit 2320A includes a MEMS mirror 2322A that receives light from the optical fiber 2250. Light from the light source unit 2360A entering one end of the

optical fiber 2250 is emitted from the other end of the optical fiber 2250 toward the MEMS mirror 2322A. Light emitted from the optical fiber 2250 spreads out according to the numerical aperture of the optical fiber 2250. Typically, therefore, a collimating lens 2260 is disposed between the optical fiber 2250 and the MEMS mirror 2322A in order to produce parallel light. As long as light emitted from the optical fiber 2250 is directly or indirectly incident on the MEMS mirror 2322A, another optical component, such as the collimating lens 2260, may be disposed between the MEMS mirror 2322A and the optical fiber 2250.

Light incident on the MEMS mirror 2322A is reflected by a movable mirror 2323 of the MEMS mirror 2322A at an angle corresponding to the inclination of the movable mirror 2323. Light reflected by the movable mirror 2323 is emitted from the lighting unit 2310 through the opening 2330 and forms an image.

FIG. 44 illustrates the structure of the projector 2300 illustrated in FIG. 42. As described above, the main body unit 2350 includes the light source unit 2360A, which includes the excitation light source 180. In this example, the light source unit 2360A in the main body unit 2350 includes the light-emitting device 100w. The main body unit 2350 can further include a driving unit 2352 for the light-emitting device 100w, a driver 2354 for the excitation light source 180, a control circuit 2356, and an input/output interface 2358.

The input/output interface 2358 can transfer electric signals to and from an external device (for example, a computer or removable memory) and can receive image data and control signals by wire or radio from an external device (for example, a server or terminal device connected to a network). For example, the control circuit 2356 includes a memory, a central processing unit (CPU), and an image-processing circuit, such as a digital signal processor (DSP), and generates image signals based on image data (or signals) input via the input/output interface 2358. The control circuit 2356 controls the operation of each unit of the projector 2300 on the basis of the input from the input/output interface 2358. For example, the control circuit 2356 sends control signals to the driver 2354 to turn on or off the excitation light source 180. The incidence of excitation light on the optical fiber 2250 may be controlled by the driver 2354 controlling the operation of a shutter disposed between the optical fiber 2250 and the excitation light source 180. The shutter can be disposed at any position between the excitation light source 180 and a light modulator 2322 described later. The control circuit 2356 also controls the driving unit 2352 (typically a motor) for rotating the light-emitting device 100w and selects the region in the light-emitting device 100w that excitation light from the excitation light source 180 enters.

In this example, the lighting unit 2310 includes a driver 2324 for driving the light modulator 2322 of the image-forming unit 2320A. The MEMS mirror 2322A is an example of the light modulator 2322. In the structure illustrated in FIG. 44, the control circuit 2356 controls the driver 2324.

11-2. Formation of Image

A method for forming images with the MEMS mirror 2322A will be described below.

FIG. 45A is a schematic view of an image formed using light reflected from the MEMS mirror 2322A. For example, the MEMS mirror 2322A includes a movable mirror supported by a minute beam and a driving mechanism (electrostatic actuator) for changing the inclination of the movable mirror. In the structure illustrated in FIG. 45A, the MEMS mirror 2322A is a two-dimensional MEMS mirror in

which the movable mirror can rotate about two orthogonal axes (α axis and β axis). The movable mirror can be tilted in a desired direction by applying an appropriate voltage as a drive signal to the MEMS mirror 2322A for an appropriate time. The inclination of the movable mirror can be controlled to reflect incident light toward a desired position in a projection target, such as a screen. A light beam reflected from the MEMS mirror 2322A can be scanned in the horizontal and vertical directions by differentiating the driving frequency with respect to the α axis and the β axis.

As illustrated in FIG. 43, light emitted from the light-emitting device 100w and transmitted through the optical fiber 2250 is directly or indirectly incident on the MEMS mirror 2322A. As described above, the light-emitting device 100w includes regions from which intense light beams of different wavelengths are emitted in a particular direction (for example, in the direction normal to the light-emitting device 100w). For example, one region in the light-emitting device 100w has a periodic structure that enhances light having a wavelength corresponding to red light, and another region has a periodic structure that enhances light having a wavelength corresponding to green light. Still another region has a periodic structure that enhances light having a wavelength corresponding to blue light. Thus, the peak wavelength of light emitted in the direction normal to the light-emitting device 100w may vary from one region to another.

Thus, the wavelength of light coupled to the optical fiber 2250 can be altered by rotating the light-emitting device 100w to change the region(s) that excitation light enters. In other words, the wavelength of light incident on the MEMS mirror 2322A can be sequentially changed. Thus, for example, red (R), green (G), and blue (B) light spots can be formed on the projection target by controlling the rotation of the light-emitting device 100w in synchronism with scanning of light beams on the projection target, as schematically illustrated in FIG. 45A. For example, a desired color image based on the image signal sent to the projector 2300 can be displayed by scanning R, G, and B light beams. In order to display black, for example, light incident on the MEMS mirror 2322A can be reflected toward a light absorber in the lighting unit 2310. Some regions in the light-emitting device 100w may have the same periodic structure, and photoluminescent materials of different emission wavelengths may be used in some regions.

A structure for emitting light having a desired wavelength from the optical fiber 2250 to the light modulator 2322 is not limited to the structure illustrated in FIG. 43. As illustrated in FIG. 45B, light having a desired wavelength may be generated by coupling optical fibers, which are optically coupled to light-emitting devices that emit intense light beams of different wavelengths, with the optical fiber 2250 via an optical fiber coupler 2252.

In the structure illustrated in FIG. 45B, light-emitting devices 100r, 100g, and 100b are disposed between the excitation light source 180 and an optical fiber 2250r, between the excitation light source 180 and an optical fiber 2250g, and between the excitation light source 180 and an optical fiber 2250b, respectively. A collimating lens 2270 is disposed between the excitation light source 180 and each of the light-emitting devices 100r, 100g, and 100b. For example, the light-emitting devices 100r, 100g, and 100b have a periodic structure, the period of which is set to emit intense light in red, green, and blue wavelength ranges, respectively, in the front direction. Thus, light in the red, green, and blue wavelength ranges enters one end of the optical fibers 2250r, 2250g, and 2250b, respectively. The

light-emitting devices **100r**, **100g**, and **100b** may be designed to include photoluminescent layers of different emission wavelengths and thereby emit intense light in different wavelength ranges. As illustrated in the figure, a converging lens **2272** may be disposed between the light-emitting device **100r** and the optical fiber **2250r**, between the light-emitting device **100g** and the optical fiber **2250g**, and between the light-emitting device **100b** and the optical fiber **2250b**.

The other end of each of the optical fibers **2250r**, **2250g**, and **2250b** is coupled to one end of the optical fiber **2250** via the optical fiber coupler **2252**. The other end of the optical fiber **2250** faces the light modulator **2322**. For example, the optical fiber coupler **2252** has a structure in which optical fibers are coupled together by fusion or a structure that utilizes a waveguide. Red light transmitted through the optical fiber **2250r**, green light transmitted through the optical fiber **2250g**, and blue light transmitted through the optical fiber **2250b** are synthesized in the optical fiber coupler **2252**, and the synthesized light is emitted from the other end of the optical fiber **2250**. Light having a desired color (spectrum) can be emitted from the other end of the optical fiber **2250** by adjusting the output of the excitation light source **180**. Thus, the color of a light beam traveling toward the projection target can be changed. The intensity of excitation light emitted from the excitation light source **180** can be controlled by drivers **2354r**, **2354g**, and **2354b** each coupled to the excitation light source **180**. These drivers **2354r**, **2354g**, and **2354b** are controlled by the control circuit **2356**, for example.

An aperture for each color may be disposed between the light-emitting device **100r** and the optical fiber **2250r**, between the light-emitting device **100g** and the optical fiber **2250g**, and between the light-emitting device **100b** and the optical fiber **2250b**, and the degree of opening of the aperture may be controlled by the drivers **2354r**, **2354g**, and **2354b**. The intensity ratio of light beams to be synthesized can be adjusted by changing the degree of opening of the aperture. Thus, synthesized light can have any desired color. Although red light, green light, and blue light are synthesized in the present example, the wavelength range of light to be synthesized and the number of light-emitting devices are not particularly limited.

11-3. Modified Examples of Projector

FIG. **46** is a schematic view of another optical system of the projector **2300**. FIG. **47** is a block diagram of the optical system illustrated in FIG. **46**.

In the structure illustrated in FIGS. **46** and **47**, the projector **2300** includes a light source unit **2360B** including the excitation light source **180**, an image-forming unit **2320B** including the MEMS mirror **2322A**, and the optical fiber **2250**, which optically couples the light source unit **2360B** with the image-forming unit **2320B**. In this example, the image-forming unit **2320B** includes the light-emitting device **100w**. In this example, as schematically illustrated in FIG. **47**, the light modulator **2322** and the light-emitting device **100w** are disposed in the lighting unit **2310**. The driving unit **2352** for the light-emitting device **100w** is also disposed in the lighting unit **2310**. The excitation light source **180** is disposed in the main body unit **2350** as in the example illustrated in FIGS. **43** and **44**.

In the structure illustrated in FIGS. **46** and **47**, one end of the optical fiber **2250** is disposed on the optical path of excitation light emitted from the excitation light source **180**. The optical fiber **2250** transmits excitation light from the excitation light source **180** to the image-forming unit **2320B**. Excitation light emitted from the optical fiber **2250** is

incident on the light-emitting device **100w** in the image-forming unit **2320B**. Thus, the optical fiber **2250** emits excitation light from the other end thereof toward the light-emitting device **100w**. A collimating lens may be disposed between the optical fiber **2250** and the light-emitting device **100w**.

Upon receiving excitation light, the light-emitting device **100w** emits intense light having a particular wavelength in a particular direction (for example, in the direction normal to the light-emitting device **100w**). The MEMS mirror **2322A** in the image-forming unit **2320B** receives light enhanced by the light-emitting device **100w**. Thus, the MEMS mirror **2322A** is placed such that light emitted from the light-emitting device **100w** is incident on the MEMS mirror **2322A**. As long as light enhanced by the light-emitting device **100w** is directly or indirectly incident on the MEMS mirror **2322A**, a converging lens may be disposed between the light-emitting device **100w** and the MEMS mirror **2322A**. The MEMS mirror **2322A** changes the traveling direction of incident light in accordance with the drive signal.

In this manner, excitation light generated in the light source unit **2360B** may be transmitted to the image-forming unit **2320B** via the optical fiber **2250**. A desired image can also be displayed on a screen by using such a structure.

11-4. Optical Coupling Between Light-Emitting Device and Optical Fiber

FIG. **48** is a schematic view illustrating optical coupling between a light source and an optical fiber. FIG. **48** schematically illustrates that light emitted from a light source **2280** enters the optical fiber **2250** through a converging lens **2290**.

As described above, the etendue of an optical system is preserved in the absence of diffusion. In the example illustrated in FIG. **48**, the center of the light source **2280**, the optical axis of the converging lens **2290**, and an axis L of the optical fiber **2250** are coincident. The etendue of the light source **2280** is represented by $S \sin^2\theta$, wherein θ denotes the maximum angle between diverging light emitted from the light source **2280** and the axis L, and S denotes the luminous area of the light source **2280**. The refractive index of air is assumed to be 1.

As described above, if the etendue on a light-receiving side, which represents the ability of introducing light, is smaller than the etendue of a light source, then light from the light source is not entirely introduced into the light-receiving side and is partly lost. In FIG. **48**, deep shading schematically represents light entering the optical fiber **2250**, and light shading schematically represents light not entering the optical fiber **2250** when the light source **2280** has a large etendue.

The etendue of the optical fiber **2250** on the light-receiving side can be represented by the numerical aperture NA of the optical fiber **2250**. The numerical aperture NA of the optical fiber **2250** is represented by the maximum angle θ_f between the light beam introduced into the optical fiber **2250** and the axis L. The angle θ_f depends on the conditions under which total reflection occurs in the optical fiber **2250**. When light enters the optical fiber **2250**, the etendue on a light-receiving side depends on the type of the optical fiber **2250**.

As long as the etendue on the light-receiving side is constant, the amount of light introduced into the optical fiber **2250** does not increase with increasing luminous area of the light source **2280**. The same is true even if the diameter of the converging lens **2290** between the light source **2280** and the optical fiber **2250** is increased.

FIG. 49 schematically illustrates the relationship between the luminous area S of the light source 2280 and the amount A of light introduced into the optical fiber 2250. The broken line in FIG. 49 indicates isotropic emission from the light source 2280 and a relatively large etendue of the light source 2280. The coupling efficiency between the light source 2280 and the optical fiber 2250 is approximately 20%, for example. The dash-dot line in FIG. 49 indicates high directionality and a relatively small etendue of the light source 2280. The solid line in FIG. 49 indicates complete directionality of the light source 2280 and an etendue of approximately 0. The coupling efficiency can reach approximately 100%. Thus, optical coupling between a light source having some luminous area and an optical fiber is improved when the light source has higher directionality.

The surface structure (the periodic structure 120a and/or 120b) of the light-emitting device 100w forms a quasi-guided mode in the photoluminescent layer 110. In the quasi-guided mode, light having a particular wavelength emitted from the photoluminescent layer 110 has the maximum intensity in a particular direction (for example, in the front direction). The directional angle of light having a wavelength λ_e emitted from the photoluminescent layer 110 is limited to, for example, less than 15 degrees by the surface structure of the light-emitting device 100w. This provides a narrow-angle light distribution. Since the light-emitting device 100w has a structure for controlling the directionality of emitted light, the light-emitting device 100w and the optical fiber 2250 can have high coupling efficiency. Thus, light from the light-emitting device 100w can be efficiently transmitted via the optical fiber 2250 (see FIG. 43, for example). Thus, bright images can be displayed even when the optical fiber 2250 is disposed between the light-emitting device 100w and the light modulator 2322 (the MEMS mirror 2322A). Because of high coupling efficiency between the light-emitting device 100w and the optical fiber 2250, the projector can reduce power consumption.

As illustrated in FIG. 42, in a light-emitting device according to the present disclosure, the main body unit 2350 can be optically coupled to the lighting unit 2310 via the optical fiber 2250, and all the optical components of the image forming optical system are not necessarily housed in the lighting unit 2310. Thus, the lighting unit can be easily miniaturized and has high design flexibility.

FIG. 50 is an outside drawing of a projector according to a comparative example including a lighting unit that houses all the optical components of an image forming optical system. A projector 2500 illustrated in FIG. 50 includes a lighting unit 2510 coupled to a main body unit 2550. The lighting unit 2510 has an opening 2530, in which a focusing lens 2332 is disposed.

FIG. 51 illustrates image forming components in the lighting unit 2510 of the projector 2500 illustrated in FIG. 50. The projector 2500 is a digital light processing (DLP) projector including a digital micromirror device (DMD). The lighting unit 2510 includes a light source 2580 for emitting white light, a color wheel 2520, a digital micromirror device 2322B (hereinafter referred to as "DMD 2322B") for receiving light passing through the color wheel 2520, and the focusing lens 2332. The color wheel 2520 has a disk shape and includes regions along its circumference. The regions are formed of different color filters and include a region for transmitting red light (R), a region for transmitting green light (G), a region for transmitting blue light (B), and a region for directly transmitting white light (W) emitted from the light source 2580, for example. The color wheel 2520 is rotatably supported in the lighting unit 2510

and is rotated by a driving unit (for example, a motor, not shown). The color of light entering the DMD 2322B changes with the rotation of the color wheel 2520. The DMD 2322B includes a substrate 2326 and many minute mirrors 2325 arranged on the substrate 2326. Light incident on the mirrors 2325 is reflected in a predetermined direction to form an image. In FIG. 51, for simplicity, two out of thousands of mirrors 2325 arranged in a matrix are illustrated. The structure and operation of the DMD 2322B will be described in detail later.

As illustrated in FIGS. 50 and 51, in the case that the light source 2580 is disposed in the lighting unit 2510, a relatively large component for cooling the light source 2580, such as a heat sink or fan (not shown in FIG. 51), is disposed in the lighting unit 2510. Thus, it is difficult to miniaturize the lighting unit 2510. In the generally cylindrical lighting unit 2510 illustrated in FIG. 50, the diameter and longitudinal length are approximately 20 and 30 cm, for example. The lighting unit 2510 including a large heat sink has an increased weight. For example, the lighting unit 2510 weighs approximately 3 kg.

In contrast, in a projector including a light-emitting device according to the present disclosure, since a light source unit can be optically coupled to an image-forming unit via an optical fiber, the excitation light source 180 and the light modulator 2322 can be easily separately disposed in the main body unit 2350 and the lighting unit 2310, respectively. Thus, a component that generates much heat is not necessarily disposed in the lighting unit 2310, and a heat sink is not necessarily disposed in the lighting unit 2310. Thus, the lighting unit 2310 can include no heat sink and can be decreased in size and weight. For example, the lighting unit 2310 weighs approximately 0.3 kg. Since the lighting unit 2310 can be relatively easily decreased in size and weight, the lighting unit 2310 can substitute for spotlights and downlights in houses, stores, and offices.

Laser beams have sometimes been used to display images on a screen. For example, in the optical system illustrated in FIG. 51, the light source 2580 may be a laser diode (LD). A projector according to the present disclosure displays images using light emitted from the light-emitting device 100w. Upon receiving excitation light, the projector emits light from the light-emitting device 100w toward a projection target. Thus, the projector offers a higher level of safety. When a laser beam is used to display images, speckle noise must be prevented. A projector according to the present disclosure does not use a laser beam to display images and requires no particular mechanism for reducing speckle noise.

11-5. Other Modified Examples of Projector

FIGS. 52 and 53 illustrate still another optical system of the projector 2300. As illustrated in FIGS. 52 and 53, the light modulator 2322 may be the DMD 2322B illustrated in FIG. 51.

In the structure illustrated in FIG. 52, the projector 2300 includes the light source unit 2360A, an image-forming unit 2320C including the DMD 2322B, and the optical fiber 2250, which optically couples the light source unit 2360A with the image-forming unit 2320C. The light source unit 2360A and the image-forming unit 2320C are disposed in the main body unit 2350 and the lighting unit 2310, respectively (see FIG. 42).

Light generated in the light source unit 2360A is transmitted to the image-forming unit 2320C via the optical fiber 2250. Light emitted from the optical fiber 2250 is directly or indirectly incident on the DMD 2322B. In this example, a lens system 2340 is disposed between the optical fiber 2250

and the DMD 2322B. The lens system 2340 expands light emitted from the optical fiber 2250. The DMD 2322B is uniformly irradiated with a light beam expanded by the lens system 2340.

As described above, the DMD 2322B includes many minute mirrors 2325 arranged on the substrate 2326. Each of the mirrors 2325 supported by the substrate 2326 can be tilted at a desired angle with an actuator (not shown). The inclination of each of the mirrors 2325 can be changed by approximately 10 degrees according to the digital input signal sent from the driver 2324 (see FIG. 44). Each of the mirrors 2325 reflects incident light toward the focusing lens 2332 or a light absorber in the lighting unit 2310 depending on its inclination. As described above, the wavelength of light incident on the DMD 2322B through the optical fiber 2250 can be changed by rotating the light-emitting device 100w. Thus, a desired color image can be displayed on a screen by independently changing the inclination of each of the mirrors 2325 in synchronism with the rotation of the light-emitting device 100w (for example, at a frequency of thousands per second).

As described above, the light modulator 2322 can be a DMD, and the light-emitting device 100w can be optically coupled to the DMD via the optical fiber 2250. This embodiment of the present disclosure can achieve high coupling efficiency between the light-emitting device 100w and the optical fiber 2250 and can provide an optical system with low optical loss. Thus, bright images can be displayed. Furthermore, since the excitation light source 180 can be disposed in the main body unit 2350, this embodiment has the same advantages as the structure illustrated in FIGS. 43 and 46.

As in the structure illustrated in FIG. 46, the light-emitting device 100w may be disposed in the lighting unit 2310. In FIG. 53, the light-emitting device 100w is disposed in the lighting unit 2310. In the structure illustrated in FIG. 53, the image-forming unit 2320D in the lighting unit 2310 includes the DMD 2322B and the light-emitting device 100w. Even in this structure, the excitation light source 180 is disposed in the main body unit 2350, and the structure has the same advantages as the structure illustrated in FIGS. 43 and 46.

In addition to these embodiments, the technique of the present disclosure can be variously modified. For example, the light modulator 2322 may be based on the liquid crystal on silicon (LCOS) technology. The light modulator 2322 reflects or transmits incident light to form images. In the embodiments described above, the wavelength of light incident on the light modulator 2322 is changed by selecting the region(s) in the light-emitting device 100w that excitation light enters. However, without being limiting to these embodiments, a light-emitting device may be independently disposed for each of the wavelength ranges (for example, red, green, and blue) used to form color images.

12. Light-Emitting Apparatus Including Support for Photoluminescent Layer

Still another modified example of a light-emitting apparatus according to the present disclosure will be described below.

FIG. 54A is a schematic cross-sectional view of a light-emitting apparatus including a light-emitting device 100' and a support 3540 for supporting the light-emitting device 100'. FIG. 54B is a plan view of the light-emitting apparatus, as viewed from above in FIG. 54A. Although the light-emitting device 100' has a very large surface structure 120

in these figures, the surface structure 120 can practically have many fine projections or recesses. This is also true in the other figures in the present disclosure. In the light-emitting apparatus illustrated in FIGS. 54A and 54B, the support 3540 surrounds and supports the light-emitting device 100'.

The support 3540 is in contact with the side of the light-emitting device 100' and fixes the light-emitting device 100'. Advantageously, the support 3540 protects the light-emitting device 100' and makes it easy to hold the light-emitting apparatus. The support 3540 can be composed of a material having a higher thermal conductivity than the photoluminescent layer 110. This allows the support 3540 to function as a heat bath or heat sink for dissipating heat generated in the photoluminescent layer 110.

Without a heat bath for dissipating heat, the photoluminescent layer 110 may be heated in high power operation and have low luminous efficiency. The support 3540 having high thermal conductivity in contact with the photoluminescent layer 110 can promote heat dissipation and suppress the decrease in luminous efficiency. The support 3540 can be composed of a material having a relatively high thermal conductivity, such as aluminum, brass, or copper. Another material may also be used. In the case that the support 3540 is provided in order to protect the light-emitting device 100' from impacts, the support 3540 may be composed of a material having a lower thermal conductivity than the photoluminescent layer 110.

The light-emitting device 100' can have the structure of any of the light-emitting devices according to the present disclosure described above. For example, in FIG. 54A, the light-emitting device 100' includes a light-transmissive layer 3520 and the photoluminescent layer 110 on the substrate 140. A surface structure (typically a periodic structure) 120 is disposed between the light-transmissive layer 3520 and photoluminescent layer and between the photoluminescent layer 110 and the air layer. This structure is particularly effective when the substrate 140 is composed of an inexpensive transparent material, such as soda-lime glass or borosilicate glass. However, the substrate 140 composed of such an inexpensive glass may be damaged in a process of sintering a photoluminescent material in the production of the light-emitting device 100'. In order to avoid this, it is effective to form the light-transmissive layer 3520 formed of a heat-resistant material (for example, SiO₂, Al₂O₃, MgO, SiN, Ta₂O₅, or TiO₂) and having the surface structure 120 on the low-cost substrate 140. The light-transmissive layer 3520 can block sintering heat when the photoluminescent layer 110 is heated with a laser beam for a short time and thereby protect the substrate 140 from damage. The structure of the light-emitting device 100' is not limited to the structure illustrated in FIG. 54A and can be variously modified as described later.

In FIG. 54A, the light-emitting apparatus further includes an excitation light source 3510. The excitation light source 3510 obliquely irradiates the bottom of the light-emitting device 100' (the interface between the substrate 140 and the air) with excitation light. The incident angle of excitation light is more than 0 degrees. Preferably, a light introducing structure is provided such that excitation light is totally reflected in the photoluminescent layer 110. As illustrated in FIG. 54C, the light introducing structure may be a triangular prism disposed on the substrate 140 facing the excitation light source 3510. The light introducing structure 3590 (a triangular prism in this example) may be another structure, such as a hemisphere, pyramid, diffraction grating, or blazed diffraction grating. Such a structure can reduce reflection

from the surface of the substrate **140** and allows excitation light to efficiently enter the photoluminescent layer **110**. Such a structure is described in detail as a light guide structure in Japanese Patent Application No. 2015-031515 filed by the same applicant. Japanese Patent Application No. 2015-031515 is incorporated herein by reference in its entirety. The position and orientation of the excitation light source **3510** are adjusted so as to satisfy the incident angle. Consequently, excitation light enters the photoluminescent layer **110** at an angle with respect to the direction normal to the photoluminescent layer **110** and propagates through the photoluminescent layer **110**. This improves luminous efficiency compared with excitation light perpendicularly incident on the photoluminescent layer **110**.

The surface structure **120** emits intense light having a particular wavelength in a particular direction. Thus, the surface structure **120** also most strongly emits excitation light in a particular direction. The excitation light source can be disposed such that excitation light enters the light-emitting device **100'** at the same angle as its output angle θ_{out} . This allows excitation light to efficiently enter the photoluminescent layer **110** and improves luminous efficiency.

The support **3540** illustrated in FIGS. **54A** to **54C** can be wide open for the excitation light source **3510** such that excitation light can obliquely enter the light-emitting device **100'**. The opening has a side surface **3540a** inclined with respect to the direction normal to the photoluminescent layer **110**. The opening widens gradually from a portion **3540b** in contact with the light-emitting device **100'** (referred to as a "supporting portion") toward the excitation light source **3510**. In other words, the opening has a tapered side surface. Excitation light can obliquely enter the light-emitting device **100'** along the side surface **3540a** of the opening. Although the opening in FIGS. **54A** to **54C** is a truncated pyramid having a square bottom, the opening may have any shape, provided that the opening does not interfere with the optical path of excitation light. For example, the opening may have a step instead of the tapered side surface **3540a**.

As in the embodiments described above, the light-emitting apparatus illustrated in FIGS. **54A** to **54C** has the surface structure **120** for limiting the directional angle of light having a particular wavelength. This can improve the directionality of light having a particular wavelength. The light-emitting device **100'** is fixed to the support **3540** such that a portion of the light-emitting device **100'** on which excitation light is incident (the bottom of the substrate **140**) is exposed. Thus, excitation light can enter the light-emitting device **100'** at a desired angle while the light-emitting device **100'** is protected. If the support **3540** is composed of a material having a higher thermal conductivity than the photoluminescent layer **110**, the light-emitting apparatus can have good heat dissipation characteristics and is less likely to have low luminous efficiency.

FIGS. **55A** and **55B** illustrate another example of the light-emitting device **100'** having a different structure. In this light-emitting device **100'**, the light-transmissive layer **3520** and the surface structure **120** on the surface thereof are eliminated from the structure illustrated in FIGS. **54A** and **54B**. More specifically, the light-emitting device **100'** includes the substrate **140**, the photoluminescent layer **110** disposed on the substrate **140**, and the surface structure **120** on the surface of the photoluminescent layer **110**. The components other than the light-emitting device **100'** are the same as in FIGS. **54A** and **54B**. In FIGS. **55A** and **55B**, the surface structure **120** is only disposed on top of the photoluminescent layer **110**, and therefore the production process

can be simplified. This structure is particularly effective when the substrate **140** is composed of heat-resistant quartz glass. Because of its high heat resistance, quartz glass is less likely to be damaged by sintering of the photoluminescent material. Thus, the photoluminescent layer **110** can be directly formed on the substrate **140**, and the surface structure **120** can be formed on the photoluminescent layer **110**.

FIGS. **56A** and **56B** illustrate still another example of the light-emitting device **100'** having a different structure. In this light-emitting device **100'**, the surface structure **120** on the photoluminescent layer **110** is eliminated from the structure illustrated in FIGS. **54A** and **54B**. More specifically, the light-emitting device **100'** includes the substrate **140**, the light-transmissive layer **3520** disposed on the substrate **140**, the surface structure **120** on the surface of the light-transmissive layer **3520**, and the photoluminescent layer **110** disposed on the light-transmissive layer **3520**. The surface structure **120** is disposed only at the interface between the photoluminescent layer **110** and the light-transmissive layer **3520**. This structure can also simplify the production process.

In FIGS. **57A** and **57B**, the support **3540** has a structure different from the structure illustrated in FIGS. **54A** and **54B**. As illustrated in FIG. **57B**, the shape of the outer and inner peripheries of the side surface **3540a** of the support **3540** is circular rather than tetragonal, as viewed in the direction perpendicular to the photoluminescent layer. In other words, the opening is truncated conical rather than truncated pyramidal. Except for this, the structure is the same as the structure illustrated in FIGS. **54A** and **54B**. This structure also has the same advantages as the structure illustrated in FIGS. **54A** and **54B**.

In FIGS. **58A** and **58B**, the support **3540** of the light-emitting apparatus illustrated in FIGS. **55A** and **55B** is substituted by the support illustrated in FIGS. **57A** and **57B**. Having a difference only in the shape of the side surface of the opening in the support, this structure has the same advantages as the structure illustrated in FIGS. **55A** and **55B**.

In FIGS. **59A** and **59B**, the support **3540** of the light-emitting apparatus illustrated in FIGS. **56A** and **56B** is substituted by the support illustrated in FIGS. **57A** and **57B**. Having a difference only in the shape of the side surface of the opening in the support, this structure has the same advantages as the structure illustrated in FIGS. **56A** and **56B**.

FIGS. **60A** and **60B** illustrate a light-emitting apparatus in which the support **3540** is disposed only on the side surface of the light-emitting device **100'**. In this example, the periphery of the support **3540** does not protrude toward the excitation light source **3510**; that is, the support **3540** does not have an opening facing the excitation light source **3510**. Except for this, the structure is the same as the structure illustrated in FIGS. **54A** and **54B**. This example can provide a directional-light-emitting apparatus having a simple structure and high impact resistance or good heat dissipation characteristics.

In a light-emitting apparatus illustrated in FIGS. **61A** and **61B**, the light-emitting device **100'** in the structure illustrated in FIGS. **60A** and **60B** is substituted by the light-emitting device illustrated in FIGS. **55A** and **55B**. This example can also provide a directional-light-emitting apparatus having a simple structure and good heat dissipation characteristics.

In a light-emitting apparatus illustrated in FIGS. **62A** and **62B**, the light-emitting device **100'** in the structure illustrated in FIGS. **60A** and **60B** is substituted by the light-

emitting device illustrated in FIGS. 56A and 56B. This example can also provide a directional-light-emitting apparatus having a simple structure and good heat dissipation characteristics.

In FIGS. 63A and 63B, the structure of the support 3540 of the light-emitting apparatus illustrated in FIGS. 54A and 54B is substituted by still another structure. The support 3540 has an opening 3540c extending along the optical path of excitation light from a supporting portion 3540b disposed in contact with the light-emitting device 100'. The opening 3540c functions as a light guide path for directing excitation light to the light-emitting device 100'. Excitation light emitted from the excitation light source 3510 travels through the opening 3540c and obliquely enters the bottom of the light-emitting device 100'. This structure can also provide a directional-light-emitting apparatus having high impact resistance or good heat dissipation characteristics.

In a light-emitting apparatus illustrated in FIGS. 64A and 64B, the light-emitting device 100' in the structure illustrated in FIGS. 63A and 63B is substituted by the light-emitting device illustrated in FIGS. 55A and 55B. In a light-emitting apparatus illustrated in FIGS. 65A and 65B, the light-emitting device 100' in the structure illustrated in FIGS. 63A and 63B is substituted by the light-emitting device illustrated in FIGS. 56A and 56B. Having a difference only in the structure of the light-emitting device 100', these examples have the same advantages as the example illustrated in FIGS. 63A and 63B.

A structure illustrated in FIGS. 66A and 66B includes a reflecting mirror (reflector) 3530 in a light guide path. The reflector reflects excitation light. The light-emitting device 100' can have the structure illustrated in FIGS. 54A and 54B. In this example, the opening 3540c (light guide path) in the support 3540 has a bend at which a reflector 3530 is disposed. The reflector 3530 has a high reflectance in a wavelength range of excitation light. The reflector 3530 is not limited to a general mirror and may be a dichroic mirror. Excitation light reflected from the reflector 3530 enters the bottom of the light-emitting device 100'. The reflector 3530 in the light guide path relaxes location constraints on the excitation light source 3510. This structure can provide a small light-emitting apparatus.

In FIGS. 67A and 67B, the light-emitting device 100' in the light-emitting apparatus illustrated in FIGS. 66A and 66B is substituted by the light-emitting device illustrated in FIGS. 55A and 55B. In FIGS. 68A and 68B, the light-emitting device 100' in the light-emitting apparatus illustrated in FIGS. 66A and 66B is substituted by the light-emitting device illustrated in FIGS. 56A and 56B. Having a difference only in the structure of the light-emitting device 100', these examples have the same advantages as the example illustrated in FIGS. 66A and 66B.

In structures illustrated in FIGS. 69A to 71B, excitation light enters a side surface of the photoluminescent layer 110. An example illustrated in FIGS. 69A and 69B includes the light-emitting device 100' illustrated in FIGS. 54A and 54B. An example illustrated in FIGS. 70A and 70B includes the light-emitting device 100' illustrated in FIGS. 55A and 55B. An example illustrated in FIGS. 71A and 71B includes the light-emitting device 100' illustrated in FIGS. 56A and 56B. In the examples illustrated in FIGS. 69A to 71B, the support 3540 has an opening (light guide path) 3540c extending from a side surface (not a main surface) of the photoluminescent layer 110 toward the excitation light source 3510. Excitation light travels through the opening 3540c and obliquely enters the side surface of the photoluminescent layer 110. Thus, excitation light directly enters the photolu-

minescent layer 110. These structures can provide a directional-light-emitting apparatus particularly miniaturized in the vertical direction (in the direction perpendicular to the photoluminescent layer).

FIGS. 72A to 75B illustrate a light-emitting apparatus that includes radiating fins 3560 in addition to the support 3540. In a structure illustrated in FIGS. 72A and 72B, the radiating fins 3560 are added to the light-emitting apparatus illustrated in FIGS. 55A and 55B. In a structure illustrated in FIGS. 73A and 73B, the radiating fins 3560 are added to the light-emitting apparatus illustrated in FIGS. 64A and 64B. In a structure illustrated in FIGS. 74A and 74B, the radiating fins 3560 are added to the light-emitting apparatus illustrated in FIGS. 67A and 67B. In a structure illustrated in FIGS. 75A and 75B, the radiating fins 3560 are added to the light-emitting apparatus illustrated in FIGS. 70A and 70B. Although the light-emitting device 100' in these examples is the light-emitting device illustrated in FIGS. 55A and 55B, the light-emitting device 100' may have any of the structures described above.

In the examples illustrated in FIGS. 72A to 75B, the radiating fins 3560 are attached at regular intervals to the periphery of the support 3540 surrounding the light-emitting device 100'. The support 3540 and the radiating fins 3560 are composed of a material having a higher thermal conductivity than the photoluminescent layer 110 (for example, aluminum, brass, or copper). The radiating fins 3560 and the support 3540 may be composed of the same material or different materials. Heat generated in the photoluminescent layer 110 is dissipated by the radiating fins 3560 via the support 3540. This can further improve the heat dissipation characteristics of the directional-light-emitting apparatus. The shape and position of the radiating fins 3560 are not limited to those illustrated in the figures. The radiating fins 3560 may have any structure that can efficiently dissipate heat.

Although the support 3540 is a single continuous structure and entirely surrounds the light-emitting device 100' in the examples described above, the support 3540 is not limited to such a structure. For example, as illustrated in FIG. 76A, the support 3540 is interrupted around the light-emitting device 100', and the photoluminescent layer 110 is partly exposed. As illustrated in FIG. 76B, the support 3540 is divided into two portions, which hold the light-emitting device 100' therebetween. Like these, the support 3540 is not necessarily a single continuous structure. The support 3540 may have any structure that fixes the light-emitting device 100' and is partly open so as not to interfere with the optical path of excitation light and so as to expose a portion of the light-emitting device 100' that excitation light enters. For example, the support 3540 may be in contact with only a portion of the photoluminescent layer 110.

13. Light Source Unit Including Reflector

FIG. 77 is a schematic view of the structure of a light source unit (light-emitting apparatus) including a reflector (reflective member). A light source unit 4500 illustrated in FIG. 77 includes an excitation light source 4510, a light-emitting device 100a, a reflector 4530, and a collimating lens 4520. The light-emitting device 100a has the structure of the light-emitting device 100a illustrated in FIG. 1C. A light-emitting device having one of the other structures described above may be used instead of the light-emitting device 100a. Although the light-emitting device 100a has a

very large surface structure **120** in FIG. 77, the surface structure **120** can practically have many fine projections or recesses.

The reflector **4530** is a reflective member having a high reflectance in a wavelength range of excitation light. For example, the reflector **4530** may be a general mirror composed of an alloy of metals or a dichroic mirror formed of a dielectric multilayer film. The reflector **4530** is disposed on the optical path of excitation light emitted from the excitation light source **4510** and reflects and directs excitation light to the light-emitting device **100a**. The position and orientation of the excitation light source **4510** and the reflector **4530** are adjusted such that excitation light is totally reflected in the photoluminescent layer **110**.

The collimating lens **4520** is disposed between the excitation light source **4510** and the reflector **4530**. When the excitation light source **4510** is a laser diode, excitation light is generally emitted as a wide light beam. The wide light beam is converted into parallel light by the collimating lens **4520** and enters the reflector **4530**. Although the collimating lens **4520** in FIG. 77 is a single lens, the collimating lens **4520** may be a combination of lenses. The shape of the collimating lens **4520** may also be appropriately designed for the required performance.

The light-emitting device **100a** includes the photoluminescent layer **110** for emitting light having a wavelength λ_a in air upon receiving excitation light, the substrate **140** (typically a transparent substrate), and the surface structure **120** (typically a periodic structure) formed on the photoluminescent layer **110**. The surface structure **120** may be one of the surface structures described above. The directional angle of light having a wavelength λ_a emitted from the photoluminescent layer **110** is limited to, for example, less than 15 degrees by the surface structure **120**. This provides a narrow-angle light distribution.

In the light source unit **4500** illustrated in FIG. 77, excitation light is reflected from the reflector **4530** and then enters the photoluminescent layer **110**. The optical path of excitation light is bent before excitation light enters the photoluminescent layer **110**. This can improve the degree of freedom in the positional relationship between the excitation light source **4510** and the light-emitting device **100a**. Thus, the light source unit **4500** can be miniaturized.

FIG. 78 illustrates a light source unit without the reflector **4530**, for comparison purposes. In the light source unit **4500c** illustrated in FIG. 78, the excitation light source **4510** is disposed away from the light-emitting device **100a** such that excitation light can obliquely enter the light-emitting device **100a**. Consequently, the light source unit **4500c** is larger than the light source unit **4500** illustrated in FIG. 77 in the direction parallel to the layers of the light-emitting device **100a**.

FIG. 79 illustrates another structure. In this example, the position and orientation of the excitation light source **4510** and the orientation of the reflector **4530** are different from those illustrated in FIG. 77. The excitation light source **4510** emits excitation light in a direction almost perpendicular to a main surface of the photoluminescent layer **110**. The excitation light is reflected from the reflector **4530** and obliquely enters the photoluminescent layer **110**. This structure can also miniaturize the apparatus in the same manner as in FIG. 77.

FIG. 80 illustrates still another structure. In this example, the light-emitting apparatus includes a member (referred to as a support) **4540** for supporting the light-emitting device **100a**. The support **4540** surrounds and supports the light-emitting device **100a**. Although the support **4540** in FIG. 80

appears to be separated into two portions, the support **4540** is practically a single continuous structure. Advantageously, the support **4540** protects the light-emitting device **100a** and makes it easy to hold the light-emitting apparatus.

A portion of the support **4540** is a reflector **4530** formed of a material that reflects excitation light. The reflector **4530** reflects and directs excitation light to the photoluminescent layer **110**. Thus, this structure has the same function as the structure illustrated in FIG. 79. In this example, the support **4540** and the reflector **4530** are integrated and thereby improve impact resistance. If the support **4540** is composed of a material having high thermal conductivity, the support **4540** can function as a heat sink for efficiently dissipating heat generated in the light-emitting device **100a**.

FIG. 81 illustrates a modified example of FIG. 80. In a light-emitting apparatus according to this example, the support **4540** has a structure different from the structure illustrated in FIG. 80. The support **4540** houses and protects the excitation light source **4510** and the collimating lens **4520** as well as the light-emitting device **100a**. A slope near a portion that holds the light-emitting device **100a** functions as the reflector **4530**. The excitation light source **4510**, the collimating lens **4520**, the reflector **4530**, and the light-emitting device **100a** are supported while having a predetermined positional relationship. This structure can prevent the optical path of excitation light from being changed by impacts. Thus, the structure can further improve impact resistance.

FIG. 82 illustrates another modified example. A light-emitting apparatus according to this example includes the light-emitting device **100a**, a laser module **4580**, a safety filter **4560**, a lens **4550**, a reflector **4530**, and a support **4540** for supporting these components. The laser module **4580** includes an excitation light source **4510** including a laser diode and a collimating lens **4520**. Excitation light emitted from the excitation light source **4510** passes through the collimating lens **4520**, is reflected from the reflector **4530**, and enters the light-emitting device **100a** at an optimum angle.

When a laser diode is used as the excitation light source **4510**, part of excitation light not converted by the light-emitting device **100a** passes through the light-emitting device **100a**. The laser beam passing through the light-emitting device **100a** is coherent and may cause damage to the human body, particularly to the eye. In order to prevent the leakage of the laser beam, the safety filter **4560** removes light having a wavelength of excitation light emitted from the excitation light source **4510**. The lens **4550** converges light passing through the safety filter **4560**, for example, into an optical fiber.

The reflector **4530** includes a rotating shaft **4570** that functions as an angle control mechanism. The reflector **4530** can be manually rotated about the rotating shaft **4570**. In this structure, the incident angle of excitation light on the light-emitting device **100a** can be freely adjusted. For example, the incident angle of excitation light can be manually adjusted before product delivery. The angle control mechanism may also be an automatic angle control mechanism including a combination of a motor and a control circuit for driving the motor. Instead of the reflector **4530** having an angle control mechanism, the excitation light source **4510** may have an angle control mechanism. Such an angle control mechanism may be a mechanism for rotating the excitation light source **4510** about a rotating shaft.

In the example illustrated in FIG. 82, the support **4540** holds the lens **4550**, the safety filter **4560**, the light-emitting device **100a**, the reflector **4530**, and the laser module **4580**. This prevents the positional relationship between these

components from being changed by impacts and provides a light-emitting apparatus with operational stability.

The reflector **4530** can bend the optical path of excitation light emitted from the excitation light source **4510** and thereby allows excitation light to enter the photoluminescent layer **110**. This can improve the degree of freedom in the positional relationship between the excitation light source **4510** and the light-emitting device **100a** and miniaturize the apparatus.

FIG. **83** illustrates another modified example of a light-emitting apparatus including the support **4540**. The light-emitting apparatus includes the excitation light source **4510**, the collimating lens **4520**, the light-emitting device **100a**, and a support **4540** for supporting these components. This example includes no reflector. Excitation light emitted from the excitation light source **4510** passes through the collimating lens **4520** and enters the photoluminescent layer of the light-emitting device **100a** at a desired angle. The excitation light source **4510**, the collimating lens **4520**, and the light-emitting device **100a** are integrated with the support **4540** and thereby improve impact resistance.

The miniaturization effects of a light source unit including the reflector **4530** will be described in the following specific example.

FIGS. **84A** to **84C** illustrate the effects of the reflector **4530**. FIG. **84A** illustrates a light source unit that includes a known light-emitting device **700c** not having high directionality. FIG. **84B** illustrates a light source unit that includes a light-emitting device according to an embodiment of the present disclosure and no reflector. FIG. **84C** illustrates a light source unit that includes a light-emitting device according to an embodiment of the present disclosure and a reflector.

In these structures, a laser diode (LD) is used as the excitation light source **4510**. Each of the light source units can be used as a component of lighting apparatuses. For example, a lighting apparatus suitable for an 8-mat (tatami) (approximately 13 m²) room should emit a light beam of approximately 5000 lumen (lm). If each LD has a light output of approximately 4.3 W, and a light beam emitted from each light source unit in the front direction is 500 lm, then approximately 10 light-emitting modules need to be integrated. Thus, it is necessary to miniaturize each light-emitting module.

The light source unit illustrated in FIG. **84A** includes a known light-emitting device **700c** having low directionality. Thus, many excitation light sources **4510** are needed to emit a light beam of 500 lm in the front direction. This increases the size of each light source unit and the size of a lighting apparatus in which many light source units are integrated.

The light source unit illustrated in FIG. **84B** includes the light-emitting device **100a** having high directionality according to an embodiment of the present disclosure. Thus, for example, one excitation light source **4510** can emit a light beam of 500 lm in the front direction. This can reduce the size of each light source unit and the size of a lighting apparatus. If the light source unit illustrated in FIG. **84A** has a volume of 100, the volume of the light source unit illustrated in FIG. **84B** can be decreased to 62.5, for example.

In the light source unit illustrated in FIG. **84C**, a light beam of excitation light is bent by the reflector **4530** toward the light-emitting device **100a**. This can further reduce the size of each light source unit. Consequently, a lighting apparatus can have a much smaller size. If the light source unit illustrated in FIG. **84A** has a volume of 100, the volume

of the light source unit illustrated in FIG. **84C** can be decreased to 36, for example.

14. Light-Emitting Apparatus Including Additional Light Source

The following embodiment relates to a light-emitting apparatus for emitting light having a desired color (spectrum) by synthesizing light beams emitted from light sources. The light-emitting apparatus includes one of the light-emitting devices according to the embodiments described above (hereinafter also referred to as a “directional-light-emitting device” or “directional light source”) and another light source (hereinafter also referred to as an “additional light source”). The additional light source emits light having a different spectrum from light emitted from the directional light source. Light emitted from the directional light source and light emitted from the additional light source are synthesized inside or outside the directional light source. The synthesized light may enter an optical fiber cable (hereinafter referred to simply as an “optical fiber”). Such a light-emitting apparatus may be used for “optical fiber illumination”.

The term “synthesis” of light, as used herein, refers to a mixed state of light beams having different spectra. Each light beam after synthesis does not necessarily have the same propagation direction and spread angle. First light emitted from the directional light source and second light emitted from the additional light source are synthesized inside or outside the directional light source. In the case that the second light passes through the directional light source, the first light and the second light are synthesized in the directional light source. The first light and the second light may be synthesized by an optical system or light guide outside the directional light source.

The spectrum of light emitted from the directional light source may lack a wavelength component of the spectrum of light required for actual use. The additional light source can compensate for the lacked wavelength component. The spectrum and intensity of light emitted from each light source can be changed to adjust the color and brightness of illumination light.

FIG. **85** schematically illustrates such a light-emitting apparatus. This light-emitting apparatus includes the light-emitting device **100'**, an excitation light source **180**, an additional light source **5500**, an optical system **5520**, and an optical fiber **5530**. The optical system **5520** includes a collimating lens **5520a** and a converging lens **5520b**. Although the light-emitting device **100'** in the figure has the structure of the light-emitting device **100a** illustrated in FIG. **1C**, the light-emitting device **100'** may have another structure, such as the structure illustrated in FIG. **1A**.

The additional light source **5500** may be a light source including a laser diode or another directional-light-emitting device. The additional light source **5500** emits light having a different spectrum from light emitted from the light-emitting device **100'**. Light emitted from the additional light source **5500** contains a spectrum component that is insufficient in light emitted from the light-emitting device **100'**. For example, when white light is desired, and the light-emitting device **100'** emits light in a yellow (red and green) wavelength range, the additional light source **5500** can be configured to emit light in a blue wavelength range. Light emitted from the additional light source **5500** is negligibly absorbed or scattered, except when the light enters the photoluminescent layer at a particular angle at which the light is resonantly-coupled to a guided mode. Thus, when

light emitted from the additional light source **5500** almost perpendicularly enters the photoluminescent layer in the light-emitting device **100'** as illustrated in FIG. **85**, most of the light passes through the light-emitting device **100'**.

The excitation light source **180** is separated from the additional light source **5500** and excites a photoluminescent material in the light-emitting device **100'**, thereby inducing light emission. For example, excitation light emitted from the excitation light source **180** enters the photoluminescent layer in the light-emitting device **100'** at an angle with respect to the direction normal to the photoluminescent layer.

First light produced by excitation light entering the light-emitting device **100'** and second light emitted from the additional light source **5500** and entering the light-emitting device **100'** are synthesized in the light-emitting device **100'**. More specifically, the second light converges to a point in the photoluminescent layer in the light-emitting device **100'** and is synthesized with first light at the moment when the first light is produced at the point. Synthesized first and second light in a mixed state propagates outside the light-emitting device **100'**. The synthesized light is converted into parallel light by the collimating lens **5520a** and converges through the converging lens **5520b**. The converging light enters the optical fiber **5530**. In the optical system **5520** including the lenses **5520a** and **5520b**, the first light and second light are synthesized (gathered) and enter the optical fiber **5530**. The light in the optical fiber **5530** is emitted from the other end. Thus, light having a desired color can be emitted at a position distant from the light source unit including the light-emitting device **100'** and the additional light source **5500**. Although the optical fiber **5530** in FIG. **85** is relatively short, the optical fiber **5530** may be several to hundreds of meters in some applications.

FIG. **86** is a detailed view of a light-emitting apparatus. In addition to the light-emitting device **100'**, the additional light source **5500**, the excitation light source **180**, and the optical system **5520**, a light-emitting apparatus **5400** further includes a control circuit **5570** for controlling the excitation light source **180** and the additional light source **5500** and a connector **5580** for connecting the optical fiber **5530**. In this example, the optical fiber **5530** is disposed outside the light-emitting apparatus **5400**.

The control circuit **5570** may be an integrated circuit including a processor, such as a microcontroller, coupled to the excitation light source **180** and the additional light source **5500**. For example, the control circuit **5570** instructs the excitation light source **180** and the additional light source **5500** to change the intensity of output light according to the input from a user. This adjusts the intensity ratio of first light emitted from the light-emitting device **100'** to second light emitted from the additional light source **5500**. Consequently, the intensity and color of synthesized light can be changed. Alternatively, the intensity ratio of the first light to the second light may be adjusted by changing the size of an aperture **5540** disposed between the optical system **5520** and the light-emitting device **100'**.

The excitation light source **180** may be a laser beam source, and excitation light emitted from the excitation light source **180** enters the light-emitting device **100'** at an angle at which the excitation light is totally reflected in the photoluminescent layer in the light-emitting device **100'**. Thus, light emission can occur efficiently in the light-emitting device **100'**.

The connector **5580** is a terminal for connecting the optical fiber **5530** and is disposed on a housing of the light-emitting apparatus **5400**. The optical fiber **5530** can be

inserted into and removed from the connector **5580**. Thus, in the case that the optical fiber **5530** is a long cable laid in a building, when the light-emitting apparatus **5400** has broken down, or when the light-emitting apparatus **5400** is to be replaced with a light-emitting apparatus having different light-emitting properties, the light-emitting apparatus **5400** can be easily replaced.

As described above, the light-emitting apparatus illustrated in FIGS. **85** and **86** includes the directional light source as a first light source and the additional light source as a second light source. The first light source includes a photoluminescent layer for emitting first light containing light having a wavelength λ_a in air, a light-transmissive layer located on or near the photoluminescent layer, and a surface structure formed on a surface of at least one of the photoluminescent layer and the light-transmissive layer. The surface structure has projections or recesses or both and limits the directional angle of light having a wavelength λ_a in air emitted from the photoluminescent layer. For example, the center-to-center distance D_{int} between two adjacent projections or recesses in the surface structure and the refractive index n_{wav-a} of the photoluminescent layer for light having a wavelength λ_a in air satisfy $\lambda_a/n_{wav-a} < D_{int} < \lambda_a$. Alternatively, the surface structure has at least one periodic structure, and the refractive index n_{wav-a} of the photoluminescent layer for light having a wavelength λ_a in air and the period p_a of at least one periodic structure satisfy $\lambda_a/n_{wav-a} < p_a < \lambda_a$. Consequently, light having a wavelength λ_a in air emitted from the first light source has the maximum intensity in a first direction predetermined by the projections or recesses or both. The second light source emits second light containing light having a wavelength λ_b (different from λ_a) in air. The first light emitted from the first light source and the second light emitted from the second light source are synthesized. The synthesized light may enter one end of an optical fiber and exits from the other end.

Such a structure can compensate for a deficiency in the spectrum of the first light source, which is a directional light source, with the second light source, thereby producing light having a desired spectrum. The spectrum of the final light can be adjusted by changing the intensity ratio of the first light source to the second light source. Thus, the color and brightness of the resulting optical fiber illumination can be changed. The optical fiber may be replaced with a light diffuser plate disposed at a position at which the first light and the second light are synthesized. Light diffused by the light diffuser plate can be utilized as illumination. Likewise, in the embodiments described below, the optical fiber **5530** may be replaced with a light diffuser plate.

FIG. **87** is a schematic view of a light-emitting apparatus in which the additional light source **5500** also emits excitation light. In this example, second light emitted from the additional light source **5500** contains a light component that functions as excitation light. Part of the second light passes through the light-emitting device **100'** and is synthesized with first light emitted from the light-emitting device **100'** in the optical system **5520**. The additional light source **5500** is disposed such that excitation light enters the light-emitting device **100'** at a particular incident angle θ .

When a photoluminescent material is resonantly excited, excitation light incident at a particular angle θ can efficiently excite the photoluminescent material. In general, since the wavelength of excitation light is shorter than the wavelength of light having a narrow-angle light distribution emitted from the light-emitting device **100'**, the light having a narrow-angle light distribution is emitted at an angle smaller than the angle θ . Thus, the lens **5520a** used in this embodi-

ment has a numerical aperture (NA_{lens}) of $\sin \theta$ or more in order to introduce light at an angle in the range of 0 (front) to θ degrees. The lens **5520a** allows both light having a narrow-angle light distribution and excitation light to be introduced into the optical system **5520**.

When the lens **5520b** has the same structure as the lens **5520a**, most (ideally all) of light in the optical system **5520** can be transmitted to an optical fiber **5530** having a numerical aperture (NA_{fiber}) of $\sin \theta$ or more. When the lens **5520b** has a different structure from the lens **5520a**, the optical fiber **5530** should have a NA_{fiber} of more than $\sin \theta$, wherein θ' (different from θ) denotes the incident angle of a light beam converged into the optical fiber **5530** by the lens **5520b**.

In the embodiment illustrated in FIG. **87**, the additional light source **5500** functions as an excitation light source, and therefore the number of light sources can be decreased. This can decrease the cost and size of the apparatus.

FIG. **88** illustrates still another structure of the light-emitting apparatus. This light-emitting apparatus is different from the example described above in the structure of the optical system **5520** and the position of the additional light source **5500**. The optical system **5520** in this example includes a dichroic mirror **5520c** between the lens **5520a** and the lens **5520b**. The additional light source **5500** is disposed in front (on the right side in the figure) of the light-emitting device **100'** rather than at the back (on the left side in the figure) of the light-emitting device **100'**. Second light emitted from the additional light source **5500** enters the dichroic mirror **5520c**. The excitation light source for emitting excitation light to the light-emitting device **100'** is omitted in FIG. **88**. Likewise, the excitation light source may be omitted in the subsequent figures.

The dichroic mirror **5520c** is designed to give high transmittance of light in the wavelength range of first light emitted from the light-emitting device **100'** and have high reflectance in the wavelength range of second light emitted from the additional light source **5500**. Second light emitted from the additional light source **5500** crosses first light emitted from the light-emitting device **100'** (at right angles in FIG. **88**). The first light and the second light crosses at the dichroic mirror **5520c**. The angle of the dichroic mirror **5520c** is adjusted such that transmitted first light and reflected second light propagate in the same direction. The first light and the second light are synthesized by the dichroic mirror **5520c**, converged by the lens **5520b**, and enter the optical fiber **5530**. As in the other embodiments described above, this structure can produce light having a desired spectrum.

FIG. **89** illustrates still another structure of the light-emitting apparatus. The light-emitting apparatus is different from the other embodiments described above in that first light and second light are synthesized in the optical fiber **5530** rather than by the optical system **5520**. The optical fiber **5530** in the light-emitting apparatus branches off in two directions. One branch **5530a** is hereinafter referred to as a first optical fiber, and the other branch **5530b** is hereinafter referred to as a second optical fiber. The first optical fiber **5530a** and the second optical fiber **5530b** are joined together at a junction **5530c**. First light emitted from the light-emitting device **100'** enters the first optical fiber **5530a** through the optical system **5520**. Second light emitted from the additional light source **5500** enters the second optical fiber **5530b**. The first light and the second light are synthesized at the junction **5530c** of the optical fiber.

Also in such a structure, desired light can be emitted from the optical fiber **5530**. An optical branching and coupling unit may be disposed at the junction **5530c** of the optical

fiber **5530** illustrated in FIG. **89**. A plurality of optical fibers can be connected to the unit to form a similar structure.

FIG. **90** illustrates still another modified example of the light-emitting apparatus. In this example, the additional light source **5500** is a directional-light-emitting device similar to the light-emitting device **100'**. Like the light-emitting device **100'**, the additional light source **5500** includes a photoluminescent layer, a light-transmissive layer, and a surface structure. The surface structure of the light-emitting device **100'** limits the directional angle of light having a wavelength λ_a , whereas the additional light source **5500** limits the directional angle of light having a wavelength λ_b (different from λ_a). The light-emitting device **100'** and the additional light source **5500** may be a single multilayer structure. Also in this example, first light emitted from the light-emitting device **100'** and second light emitted from the additional light source **5500** are synthesized in the optical system **5520** and enter the optical fiber **5530**.

FIG. **91** illustrates a portion of a light-emitting apparatus including tiled directional-light-emitting devices. The light-emitting apparatus includes one- or two-dimensionally arranged light-emitting devices (first light sources) **100r** for emitting light in a red wavelength range, light-emitting devices (second light sources) **100g** for emitting light in a green wavelength range, and light-emitting devices (third light sources) **100b** for emitting light in a blue wavelength range. Although FIG. **91** illustrates five light-emitting devices, practically, more light-emitting devices may be arranged. Light beams emitted from the light-emitting devices **100r**, **100g**, and **100b** are converged by the lens **5520d** into the optical fiber **5530**. Thus, white light can be emitted from the optical fiber **5530**. Although three light sources of red, green, and blue are used in this example, light emitted from first, second, and third light sources may have any color (spectrum). Like this example, three types of directional light sources can be combined to adjust the color of output light having greater flexibility. Although three types of light sources are used in this example, four or more light sources may be combined. Second and third light sources are not limited to directional-light-emitting devices and may be another light source, such as a laser beam source.

FIG. **92** illustrates still another example of the light-emitting apparatus. The additional light source **5500** in this light-emitting apparatus also functions as an excitation light source. First light and second light are synthesized in the optical fiber **5530**. First light emitted from the light-emitting device **100'** is converged by the lens **5520a** and a lens **5520e** into a first optical fiber **5530a** of a branched optical fiber **5530**. Second light emitted from the additional light source **5500** passes through the light-emitting device **100'** and is converged by the lens **5520a** and a lens **5520f** into a second optical fiber **5530b** of the branched optical fiber **5530**. Thus, the first light and the second light are synthesized at the junction **5530c** and are emitted from the optical fiber **5530**.

FIG. **93** illustrates still another example of the light-emitting apparatus. This example is similar to but is different in the number of lenses from the structure illustrated in FIG. **87**. Another lens **5520g** is disposed between the lens **5520a** and the light-emitting device **100'**. The lens **5520g** is close to the light-emitting device **100'**. Thus, even when second light emitted from the additional light source **5500** has a large incident angle, the second light passing through the light-emitting device **100'** can enter the lens **5520g**. The lens **5520a** compensates for an insufficient bending of the optical path of the second light bent by the lens **5520g**. Consequently, the optical axis of the first light emitted from the

light-emitting device 100' becomes almost parallel to the optical axis of the second light emitted from the additional light source 5500. The first light and the second light are converged by the lens 5520b into the optical fiber 5530. Although three lenses are used in this example, the number of lenses is not particularly limited. The shape, size, and position of each lens are also not limited to those in the figure and may be appropriately designed. For example, as illustrated in FIG. 94, the number of lenses in the optical system may be one (the lens 5520a). In this example, because of a small number of lenses, the light-emitting apparatus can be produced at low cost.

FIG. 95 illustrates still another structure of the light-emitting apparatus. The light-emitting apparatus includes the light-emitting device 100', the lens 5520a disposed on one side of the light-emitting device 100', a mirror (reflector) 5560 disposed on the other side, a branched optical fiber 5530, and the additional light source 5500. Excitation light emitted from the additional light source 5500 enters one branch of the optical fiber 5530. The excitation light passes through the lens 5520a and enters the light-emitting device 100'. Part of the excitation light incident on the light-emitting device 100' is absorbed into the photoluminescent layer and is converted into first light. The other part of the excitation light passes through the light-emitting device 100', is reflected from the mirror 5560, and again passes through the light-emitting device 100'. The first light emitted from the light-emitting device 100' and the excitation light (second light) passing through the light-emitting device 100' are converged by the lens 5520a into the optical fiber 5530. The first light and the second light are synthesized and emitted from the optical fiber 5530. Excitation light reflected from the mirror 5560 can be used in this manner.

Thus, a light-emitting apparatus including additional light source can be variously modified. In any of the modified examples, first light emitted from the first light source, which is a directional light source, and second light emitted from the second light source can be synthesized to produce light having a desired spectrum.

FIG. 96 illustrates a household fiber lighting system as an application example. The fiber lighting system includes a light-emitting apparatus (hereinafter also referred to as a light source unit) 5400 and optical fibers 5530. The light source unit 5400 is placed at a predetermined location around the house. Each of the optical fibers 5530 is laid from the light source unit 5400 to a place in a room where a lighting fixture is to be installed. Although the optical fibers 5530 appear as a single optical fiber in FIG. 96, they are actually a plurality of optical fibers. The structure of the light source unit 5400 is not limited to the structure illustrated in FIG. 86. The light source unit 5400 illustrated in FIG. 96 has the same structure as any of the light-emitting apparatuses illustrated in FIGS. 85 to 95. Light beams emitted from light sources including at least one directional light source are synthesized and enter the optical fibers 5530. Thus, desired light can be transmitted to a place where a lighting fixture is to be installed and can be utilized as illumination light. The color and brightness of illumination light can be adjusted to the situation by changing the outputs of the light sources. Such a fiber lighting system can be utilized not only in houses but also in various facilities, such as office buildings, underground cities, and stadiums.

The function of easily adjusting the spectrum can be applied to beautifying light color illumination and color-enhancing light color illumination techniques, for example. These techniques beautify an object to be illuminated by controlling the spectrum of the light source (the intensity

distribution as a function of light wavelength). For example, the skin can be beautified by reducing light having a wavelength in the range of approximately 570 to 580 nm responsible for darkening of the skin. Such beautifying light color illumination can be achieved by synthesizing light in a blue to green wavelength range of 570 nm or less and light in a red wavelength range of 580 nm or more using a light-emitting apparatus according to the present disclosure.

For example, foods having a red color can look fresher when a component with a wavelength of approximately 580 nm is decreased, and a red component on the long wavelength side is strengthened. This can make lean meat, red flesh of fish, and red fruit and vegetables look fresher. Such color-enhancing light color illumination can be achieved by synthesizing light in a blue to green wavelength range of 570 nm or less and light in a red wavelength range of 590 nm or more with a light-emitting apparatus according to the present disclosure. Such wavelength control can also be utilized to make scenery, such as red flowers and autumn leaves, look more vivid.

A light-emitting apparatus that can adjust the spectrum of output light as described above can be utilized to determine the degree of freshness of foods. In many foods, the spectrum of reflected light changes with a decrease in the degree of freshness. For example, a decrease in the degree of freshness of beef results in a decrease in the amount of component in a wavelength range of approximately 600 to 700 nm. Thus, the degree of freshness of a food can be easily determined by irradiating the food with only light in a wavelength range in which the reflectance of the light depends greatly on the degree of freshness and by measuring the intensity of reflected light. In some foods, the reflectance changes greatly in different wavelength ranges. Even in such a case, a light-emitting apparatus for synthesizing light beams having different spectra emitted from light sources can be used to produce light beams in desired wavelength ranges.

15. Light-Emitting Apparatus for Synthesizing Light Beams Emitted in Different Directions

A light-emitting apparatus for synthesizing light beams in different wavelength ranges emitted from one light-emitting device will be described below. As described above, a light-emitting device according to the present disclosure emits intense light having a particular wavelength in a particular direction and emits intense light having another wavelength in another direction. Utilizing the characteristics, light beams in different wavelength ranges emitted in different directions can be synthesized by an optical system or light guide. Light beams in different wavelength ranges can be synthesized to compensate for an insufficient spectrum component of one light beam with another light beam, thereby making the light beams more similar to light having a desired spectrum. Synthesized light can be introduced into an optical fiber, for example. Such a light-emitting apparatus can be used for optical fiber illumination, for example.

FIG. 97 is a schematic view of a light-emitting apparatus for synthesizing light beams in different wavelength ranges emitted in different directions from a light-emitting device. The light-emitting apparatus includes the light-emitting device 100', an optical system 6520, and an optical fiber 6530. The optical system 6520 includes a collimating lens 6520a and a converging lens 6520b. Although the light-emitting device 100' in FIG. 97 has the same structure as the light-emitting device 100 illustrated in FIG. 1A, a light-emitting device having another structure, such as the struc-

ture illustrated in FIG. 1C, may also be used. In FIG. 97, each component is simplified and does not necessarily have its actual structure. The same is true for other figures. Although not shown in FIG. 97, an excitation light source that emits excitation light to the light-emitting device 100' may be provided.

The photoluminescent layer contains a photoluminescent material having a broad emission spectrum. Light having a wavelength λ_a emitted from the photoluminescent material has directionality in a particular direction, and light having a wavelength λ_b emitted from the photoluminescent material has directionality in another direction. A light beam containing first light having a wavelength λ_a and a light beam containing second light having a wavelength λ_b are synthesized (gathered) by the optical system 6520 and enter the optical fiber 6530. The light in the optical fiber 6530 is emitted from the other end. Thus, optical fiber illumination for emitting light having a desired spectrum at a position distant from the light source unit including the light-emitting device 100' can be provided. Although the optical fiber 6530 in FIG. 97 is relatively short, the optical fiber 6530 may be several to hundreds of meters in some applications.

FIG. 98 illustrates a detailed structure of a light-emitting apparatus. In addition to the light-emitting device 100' and the optical system 6520, a light-emitting apparatus 6400 further includes an excitation light source 180, a control circuit 6570 for controlling the excitation light source 180, and a connector 6580 for connecting the optical fiber 6530. In this example, the optical fiber 6530 is disposed outside the light-emitting apparatus 6400.

The control circuit 6570 may be an integrated circuit including a processor, such as a microcontroller, coupled to the excitation light source 180. For example, the control circuit 6570 instructs the excitation light source 180 to change the intensity of output light according to the input from a user. This can change the intensity of first light and second light emitted from the light-emitting device 100'. In addition to such control, the intensity ratio of the first light to the second light may be adjusted by changing the size of an aperture 6540 disposed between the optical system 6520 and the light-emitting device 100'. This can adjust the spectrum of synthesized light.

The excitation light source 180 may be a laser beam source, and excitation light emitted from the excitation light source 180 enters the light-emitting device 100' at an angle at which the excitation light is totally reflected in the photoluminescent layer in the light-emitting device 100'. Thus, light emission can occur efficiently in the light-emitting device 100'.

The connector 6580 is a terminal for connecting the optical fiber 6530 and is disposed on a housing of the light-emitting apparatus 6400. The optical fiber 6530 can be inserted into and removed from the connector 6580. Thus, in the case that the optical fiber 6530 is a long cable laid in a building, when the light-emitting apparatus 6400 has broken down, or when the light-emitting apparatus 6400 is replaced with a light-emitting apparatus having different light-emitting properties, the light-emitting apparatus 6400 can be easily replaced.

As described above, the light-emitting apparatus illustrated in FIGS. 97 and 98 includes a photoluminescent layer for emitting light containing first light having a wavelength λ_a in air and second light having a wavelength λ_b in air, a light-transmissive layer located on or near the photoluminescent layer, a surface structure formed on a surface of at least one of the photoluminescent layer and the light-transmissive layer, and an optical system for synthesizing

the first light and the second light. The surface structure has projections and recesses and limits the directional angle of the first light. For example, the center-to-center distance D_{int} between two adjacent projections or recesses in the surface structure and the refractive index n_{wav-a} of the photoluminescent layer for first light having a wavelength λ_a in air satisfy $\lambda_a/n_{wav-a} < D_{int} < \lambda_a$. Alternatively, the surface structure has at least one periodic structure, and the refractive index n_{wav-a} of the photoluminescent layer for light having a wavelength λ_a in air and the period p_a of at least one periodic structure satisfy $\lambda_a/n_{wav-a} < p_a < \lambda_a$. Consequently, the first light has the maximum intensity in a first direction predetermined by the projections or recesses or both, and the second light has the maximum intensity in a second direction different from the first direction. The optical system synthesizes the light beam containing the first light emitted in the first direction and the light beam containing the second light emitted in the second direction. The synthesized light may enter one end of an optical fiber and exits from the other end.

Such a structure can compensate for an insufficient spectrum component of the first light emitted in one direction with the second light. As described above, the intensity ratio of the first light to the second light can be controlled by adjusting the size of the aperture 6540. Thus, the color and brightness of the resulting optical fiber illumination can be changed. In the present embodiment, the apparatus can be advantageously miniaturized compared with the case in which light beams from light sources are synthesized. A small light-emitting apparatus can be provided that can control the spectrum by synthesizing light beams of two or more wavelengths or colors emitted from one light-emitting device. The optical fiber may be replaced with a light diffuser plate disposed at a position at which the first light and the second light are synthesized. Light diffused by the light diffuser plate can be utilized as illumination. Likewise, in the embodiments described below, the optical fiber 6530 may be replaced with a light diffuser plate.

FIG. 99 illustrates a light-emitting apparatus for producing white light by synthesizing light beams of three particular wavelengths. In this example, the light-emitting device 100' emits light beams in three wavelength ranges of red (R), green (G), and blue (B) in different directions. These three color light beams are synthesized by the optical system 6520 and enter the optical fiber 6530. Thus, white light can be emitted from the optical fiber 6530. Although red, green, and blue light beams are used to produce white light in this example, light beams of any color may be combined.

FIG. 100 illustrates first light in a first direction and second light in a second direction emitted from the light-emitting device 100' into different optical fibers 6530a and 6530b. A light-emitting apparatus in this example includes a first optical system including lenses 6520a and 6520b and a second optical system including lenses 6520c and 6520d. First light emitted from the first optical system enters the first optical fiber 6530a, and second light emitted from the second optical system enters the second optical fiber 6530b. The first optical fiber 6530a and the second optical fiber 6530b are coupled to an optical fiber 6530d via a synthesizer 6640. The first light and the second light are synthesized by the synthesizer 6640 at the junction of the two optical fibers 6530a and 6530b. This structure also has the advantages as described above.

FIG. 101 illustrates another light-emitting apparatus including coupled optical fibers. The light-emitting apparatus includes the light-emitting device 100', a lens 6520a, a lens array 6610, optical modulators 6582, optical fibers

6530, and a synthesizer 6640. In the light-emitting apparatus, red (R), green (G), and blue (B) light beams emitted in different directions from the light-emitting device 100' are converted into parallel light by the lens 6520a, are converged by the lens array 6610, and enter the optical fibers 6530 through the optical modulators 6582. Each of the optical modulators 6582 receives red, green, or blue light and outputs the light to the corresponding optical fiber 6530. The optical modulators 6582 can weaken or block unnecessary light for the optical fibers 6530. Light beams propagating through the optical fibers 6530 are synthesized by the synthesizer 6640 and are emitted from one optical fiber.

Such a structure can produce light having any spectrum. The structure can individually output light beams of three primary colors of red, green, and blue and can be utilized not only for illumination but also for display equipment, such as displays and projectors.

FIG. 102 illustrates a structure including tiled light-emitting devices 100r, 100g, and 100b instead of the light-emitting device 100' illustrated in FIG. 101. The light-emitting devices 100r, 100g, and 100b are directional-light-emitting devices that emit light in red, green, and blue wavelength ranges, respectively, at a narrow angle. The light-emitting devices 100r, 100g, and 100b are one- or two-dimensionally arranged. Although FIG. 102 illustrates five light-emitting devices, practically, more light-emitting devices may be arranged. Light beams emitted from the light-emitting devices 100r, 100g, and 100b are converged by the lens 6520a and enter the optical fibers 6530 through the lens array 6610 and the optical modulators 6582. This structure also has the same advantages as the structure illustrated in FIG. 101.

Although red, green, and blue light beams are combined in FIGS. 101 and 102, any colors may be combined. The number of colors to be combined is not limited to three and may be two or four or more.

FIG. 103 illustrates a structure in which part of light emitted from the excitation light source 180 is utilized in the structure illustrated in FIG. 97. In this example, third light (for example, blue light) containing excitation light emitted from the excitation light source 180 enters the light-emitting device 100' at an angle (incident angle θ) with respect to the direction normal to the photoluminescent layer. Part of the third light is used for light emission, and another part of the third light passes through the light-emitting device 100'. In addition to first light and second light emitted from the light-emitting device 100', the third light passing through the light-emitting device 100' is transmitted to the optical fiber 6530 via the optical system 6520. When a desired spectrum cannot be produced from light emitted from the light-emitting device 100' alone, this structure can compensate for the insufficient spectrum component(s).

As described above, when a photoluminescent material is resonantly excited, excitation light incident at a particular angle θ can efficiently excite the photoluminescent material. In general, since the wavelength of excitation light is shorter than the wavelength of light having a narrow-angle light distribution emitted from the light-emitting device 100', the light having a narrow-angle light distribution is emitted at an angle smaller than the angle θ . As described above with reference to FIG. 87, the lens 6520a having a numerical aperture (NA_{lens}) of $\sin \theta$ or more can be used to introduce light at an angle in the range of 0 (front) to θ degrees and to introduce both light having a narrow-angle light distribution and excitation light into the optical system 6520.

When the lens 6520b has the same structure as the lens 6520a, most (ideally all) of light in the optical system 6520

can be transmitted to an optical fiber 6530 having a numerical aperture (NA_{fiber}) of $\sin \theta$ or more. When the lens 6520b has a different structure from the lens 6520a, the optical fiber 6530 should have a NA_{fiber} of more than $\sin \theta'$, wherein θ' (different from θ) denotes the incident angle of a light beam converged into the optical fiber 6530 by the lens 6520b.

FIG. 104 illustrates a structure in which the position of the excitation light source 180 illustrated in FIG. 103 was changed. In this example, third light containing excitation light emitted from the excitation light source 180 perpendicularly enters the light-emitting device 100'. Because most of the third light passes through the light-emitting device 100', the components of the third light can be strengthened. However, the luminous efficiency of the photoluminescent layer decreases, and therefore another excitation light source may be provided. When another excitation light source is provided, the excitation light source 180 may be replaced with a light source that emits light in a different wavelength range from excitation light.

FIG. 105 illustrates a light-emitting apparatus in which part of light emitted from the excitation light source 180 is utilized in the structure illustrated in FIG. 100. In the light-emitting apparatus, part of third light emitted from the excitation light source 180 and passing through the photoluminescent layer enters a third optical fiber 6530c through a third optical system (lens) 6520e. The first to third optical fibers 6530a, 6530b, and 6530c are joined together at a junction. The synthesizer 6640 at the junction synthesizes first and second light emitted from the light-emitting device 100' and third light passing through the light-emitting device 100'. This structure can also produce light having a desired spectrum from light emitted from the excitation light source 180.

Thus, a light-emitting apparatus configured to synthesize light beams in different wavelength ranges emitted in different directions from a light-emitting device can be variously modified. In any of the modified examples, first light and second light emitted from a light-emitting device are synthesized to produce light having a desired spectrum.

FIG. 106 illustrates a household fiber lighting system as an application example. The fiber lighting system includes a light-emitting apparatus (hereinafter also referred to as a light source unit) 6400 and optical fibers 6530. The light source unit 6400 is placed at a predetermined location around the house. Each of the optical fibers 6530 is laid from the light source unit 6400 to a place in a room where a lighting fixture is to be installed. Although the optical fibers 6530 appear as a single optical fiber in FIG. 105, they are actually a plurality of optical fibers. The structure of the light source unit 6400 is not limited to the structure illustrated in FIG. 98. The light source unit 6400 illustrated in FIG. 106 has the same structure as any of the light-emitting apparatuses illustrated in FIGS. 97 to 105. Light beams in different wavelength ranges are synthesized and enter the optical fibers 6530. Thus, as in the application example illustrated in FIG. 96, desired light can be sent to a place where a lighting fixture is to be installed and can be used as illumination light. The color and brightness of illumination light can be adjusted to the situation by changing the synthesis ratio of light beams in different wavelength ranges.

In the embodiments illustrated in FIGS. 97 to 106, the spectrum can be easily adjusted. Thus, these embodiments can be applied to beautifying light color illumination and color-enhancing light color illumination techniques, as in the embodiments illustrated in FIGS. 85 to 96. For example, color-enhancing light color illumination can make foods, such as meat and vegetables, look more delicious, can make

scenery, such as red flowers and autumn leaves, look more vivid, or can be utilized to determine the degree of freshness of foods.

As described above, the spectrum of light has been controlled with an optical filter by removing a component or components in an unnecessary wavelength range from light emitted from a light source. This decreases light-use efficiency. In contrast, a light-emitting apparatus according to the present disclosure can emit enhanced light having a particular wavelength and does not need an optical filter. Thus, a light-emitting apparatus according to the present disclosure can have higher light-use efficiency than known light-emitting apparatuses.

Light-emitting devices and light-emitting apparatuses according to the present disclosure can be applied to various optical devices, such as lighting fixtures, displays, and projectors.

What is claimed is:

1. A light-emitting apparatus comprising:
 - an excitation light source that emits first light;
 - a light-emitting device on an optical path of the first light, the light-emitting device emitting second light having a wavelength λ_a in air; and
 - a first converging lens on an optical path of the second light, wherein:
 - the light-emitting device comprises:
 - a photoluminescent layer that emits the second light by being excited by the first light; and
 - a light-transmissive layer on the photoluminescent layer,
 - [at least one of] the photoluminescent layer [and the light-transmissive layer] has a surface structure comprising projections or recesses arranged perpendicular to a thickness direction of the [photo luminescent] photoluminescent layer,
 - the surface structure is entirely made of a light-transmissive dielectric material,
 - [at least one of the photoluminescent layer and] the light-transmissive layer has a light emitting surface perpendicular to the thickness direction, the second light emitted from the light emitting surface,
 - the surface structure limits the directional angle of the second light emitted from the light emitting surface,
 - the photoluminescent layer comprises a dielectric layer, [and]
 - the light-transmissive dielectric material is continuously formed from the dielectric layer by a same material as the dielectric layer so that the surface structure is formed as a part of the photoluminescent layer, and
 - the surface structure satisfies the following relationship:

$$m\lambda_a/n_{wav-a} < D_{int} < m\lambda_a,$$

where m is an integer, D_{int} is a center-to-center distance between adjacent two of the projections or the recesses, and n_{wav-a} is a refractive index of the photoluminescent layer for the second light.

2. The light-emitting apparatus according to claim 1, wherein the surface structure limits the directional angle of the second light emitted from the light emitting surface to less than 15 degrees.

3. The light-emitting apparatus according to claim 1, wherein the surface structure satisfies the following relationship:

$$\lambda_a/n_{wav-a} < D_{int} < \lambda_a$$

where D_{int} is a center-to-center distance between adjacent two of the projections or the recesses, and n_{wav-a} is a refractive index of the photoluminescent layer for the second light.]

4. The light-emitting apparatus according to claim 1, wherein the surface structure has at least one periodic structure that satisfies the following relationship:

$$[\lambda_a/n_{wav-a} < p_a < k_a] m\lambda_a/n_{wav-a} < p_a < m\lambda_a$$

where m is an integer, p_a is a period of the at least one periodic structure.

5. The light-emitting apparatus according to claim 1, further comprising a collimating lens between the light-emitting device and the first converging lens.

6. The light-emitting apparatus according to claim 1, further comprising a joint for an optical fiber, at an incident position of light passing through the first converging lens.

7. The light-emitting apparatus according to claim 1, further comprising a second converging lens between the excitation light source and the light-emitting device.

8. The light-emitting apparatus according to claim 7, further comprising a collimating lens between the excitation light source and the second converging lens.

9. The light-emitting apparatus according to claim 1, further comprising a collimating lens between the excitation light source and the light-emitting device.

10. The light-emitting apparatus according to claim 1, wherein the photoluminescent layer is in contact with the light-transmissive layer.

11. The light-emitting apparatus according to claim 1, wherein a thickness of the photoluminescent layer, [the] a refractive index of the photoluminescent layer, and [the] a center-to-center distance between adjacent two of the projections or the recesses are set to limit the directional angle of the second light emitted from the light emitting surface.

12. The light-emitting apparatus according to claim 1, wherein the light-transmissive dielectric material is one of magnesium fluoride (MgF_2), lithium fluoride (LiF), calcium fluoride (CaF_2), resins, magnesium oxide (MgO), indium tin oxide (ITO), silicon nitride (SiN), tantalum pentoxide (Ta_2O_5), zirconia (ZrO_2), zinc selenide (ZnSe), and zinc sulfide (ZnS).]

13. A light-emitting apparatus comprising:

- a light source that emits first light;
- a light-emitting device on an optical path of the first light, the light-emitting device emitting second light having a wavelength λ_a in air; and
- a first converging lens on an optical path of the second light, wherein:

the light-emitting device comprises a photoluminescent layer that emits the second light by being excited by the first light,

the photoluminescent layer has a surface structure comprising projections or recesses arranged perpendicular to a thickness direction of the photoluminescent layer, the surface structure is entirely made of a light-transmissive dielectric material,

the surface structure limits the directional angle of the second light,

the photoluminescent layer comprises a dielectric layer, the light-transmissive dielectric material is continuously formed from the dielectric layer by a same material as the dielectric layer so that the surface structure is formed as a part of the photoluminescent layer,

the surface structure satisfies the following relationship:

$$m\lambda_a/n_{wav-a} < D_{int} < m\lambda_a,$$

67

where m is an integer, D_{int} is a center-to-center distance between adjacent two of the projections or the recesses, and n_{wav-a} is a refractive index of the photoluminescent layer for the second light.

14. A light-emitting apparatus comprising:
 a light source that emits first light; and
 a light-emitting device on an optical path of the first light, the light-emitting device emitting second light having a wavelength λ_a in air, wherein:
 the light-emitting device comprises a waveguide that contains a photoluminescent material and emits the second light,
 the waveguide comprises a base layer and a surface structure disposed over the base layer and comprising periodic structures,
 the surface structure limits the directional angle of the second light,
 the base layer and the surface structure are continuously and entirely made of a light-transmissive dielectric material,
 the surface structure satisfies the following relationship:

$$m\lambda_a/n_{wav-a} < D_{int} < m\lambda_a$$

where m is an integer, D_{int} is a center-to-center distance between adjacent two of the projections or the recesses, and n_{wav-a} is a refractive index of the photoluminescent layer for the second light.

15. A light-emitting apparatus comprising:
 an excitation light source that emits first light;
 a light-emitting device on an optical path of the first light, the light-emitting device emitting second light having a wavelength λ_a in air; and
 a first converging lens on an optical path of the second light, wherein:
 the light-emitting device comprises:
 a photoluminescent layer that emits the second light by being excited by the first light; and
 a light-transmissive layer on the photoluminescent layer,
 the photoluminescent layer has a surface structure comprising projections or recesses arranged perpendicular to a thickness direction of the photoluminescent layer, the surface structure is entirely made of a light-transmissive dielectric material,
 the light-transmissive layer has a light emitting surface perpendicular to the thickness direction, the second light emitted from the light emitting surface,
 the surface structure limits the directional angle of the second light emitted from the light emitting surface,
 the photoluminescent layer comprises a dielectric layer, the light-transmissive dielectric material is continuously formed from the dielectric layer by a same material as the dielectric layer so that the surface structure is formed as a part of the photoluminescent layer, and

68

the surface structure has at least one periodic structure that satisfies the following relationship:

$$m\lambda_a/n_{wav-a} < p_a < m\lambda_a$$

where m is an integer, p_a is a period of the at least one periodic structure.

16. A light-emitting apparatus comprising:
 a light source that emits first light;
 a light-emitting device on an optical path of the first light, the light-emitting device emitting second light having a wavelength λ_a in air; and
 a first converging lens on an optical path of the second light, wherein:
 the light-emitting device comprises a photoluminescent layer that emits the second light by being excited by the first light,
 the photoluminescent layer has a surface structure comprising projections or recesses arranged perpendicular to a thickness direction of the photoluminescent layer, the surface structure is entirely made of a light-transmissive dielectric material,
 the surface structure limits the directional angle of the second light,
 the photoluminescent layer comprises a dielectric layer, the light-transmissive dielectric material is continuously formed from the dielectric layer by a same material as the dielectric layer so that the surface structure is formed as a part of the photoluminescent layer, and
 the surface structure has at least one periodic structure that satisfies the following relationship:

$$m\lambda_a/n_{wav-a} < p_a < m\lambda_a$$

where m is an integer, p_a is a period of the at least one periodic structure.

17. A light-emitting apparatus comprising:
 a light source that emits first light; and
 a light-emitting device on an optical path of the first light, the light-emitting device emitting second light having a wavelength λ_a in air, wherein:
 the light-emitting device comprises a waveguide that contains a photoluminescent material and emits the second light,
 the waveguide comprises a base layer and a surface structure disposed over the base layer and comprising periodic structures,
 the surface structure limits the directional angle of the second light,
 the base layer and the surface structure are continuously and entirely made of a light-transmissive dielectric material, and
 the surface structure has at least one periodic structure that satisfies the following relationship:

$$m\lambda_a/n_{wav-a} < p_a < m\lambda_a$$

where m is an integer, p_a is a period of the at least one periodic structure.

* * * * *