

(19)



(11)

**EP 4 239 604 B1**

(12)

**EUROPEAN PATENT SPECIFICATION**

(45) Date of publication and mention of the grant of the patent:  
**02.07.2025 Bulletin 2025/27**

(51) International Patent Classification (IPC):  
**G07D 7/164 (2016.01)**

(21) Application number: **23157891.5**

(52) Cooperative Patent Classification (CPC):  
**G07D 7/164**

(22) Date of filing: **22.02.2023**

**(54) PAPER SHEET THICKNESS DETECTION APPARATUS, PAPER SHEET IDENTIFICATION APPARATUS, AND PAPER SHEET HANDLING APPARATUS**

VORRICHTUNG ZUR BESTIMMUNG DER DICKE VON PAPIERBLÄTTERN, VORRICHTUNG ZUR IDENTIFIZIERUNG VON PAPIERBLÄTTERN UND VORRICHTUNG ZUR HANDHABUNG VON PAPIERBLÄTTERN

APPAREIL DE DÉTECTION D'ÉPAISSEUR DE FEUILLE DE PAPIER, APPAREIL D'IDENTIFICATION DE FEUILLE DE PAPIER ET APPAREIL DE MANIPULATION DE FEUILLE DE PAPIER

(84) Designated Contracting States:  
**AL AT BE BG CH CY CZ DE DK EE ES FI FR GB GR HR HU IE IS IT LI LT LU LV MC ME MK MT NL NO PL PT RO RS SE SI SK SM TR**

(72) Inventors:  
• **NGUYEN, Viet**  
Tokyo 141-8576 (JP)  
• **MIURA, Yousuke**  
Tokyo 141-8576 (JP)

(30) Priority: **02.03.2022 JP 2022032201**

(74) Representative: **MERH-IP Matias Erny Reichl Hoffmann**  
**Patentanwälte PartG mbB**  
**Paul-Heyse-Straße 29**  
**80336 München (DE)**

(43) Date of publication of application:  
**06.09.2023 Bulletin 2023/36**

(73) Proprietor: **Hitachi Channel Solutions, Corp.**  
**Tokyo 141-8576 (JP)**

(56) References cited:  
**JP-A- 2000 357 254 JP-A- 2020 059 559**  
**US-A- 4 378 109 US-A1- 2005 056 575**

**EP 4 239 604 B1**

Note: Within nine months of the publication of the mention of the grant of the European patent in the European Patent Bulletin, any person may give notice to the European Patent Office of opposition to that patent, in accordance with the Implementing Regulations. Notice of opposition shall not be deemed to have been filed until the opposition fee has been paid. (Art. 99(1) European Patent Convention).

**Description**

## BACKGROUND OF THE INVENTION

## Field of the Invention

**[0001]** The present invention relates to a paper sheet thickness detection apparatus, a paper sheet identification apparatus, and a paper sheet handling apparatus.

## Description of the Related Art

**[0002]** Conventionally, there has been a banknote identification apparatus for identifying the type and authenticity of banknotes that are paper sheets, in an automatic cash transaction apparatus such as an automatic teller machine (ATM: Automatic Teller Machine) and an automatic cash dispenser (CD: Cash Dispenser). The banknote identification apparatus includes a banknote thickness detection apparatus, and performs denomination determination, authenticity determination, and detection of foreign matter adhesion to a banknote based on the thickness of the banknote detected by the banknote thickness detection apparatus. The banknote thickness detection apparatus includes a plurality of reference rollers, a plurality of detection rollers, and a plurality of displacement sensors that detect a displacement amount by which the detection rollers displace according to a thickness of a banknote with the reference rollers as a reference, when the banknote to be conveyed is sandwiched between the reference rollers and the detection rollers. Furthermore, Patent Literatures 2 to 5 each disclose further devices for measuring the thickness of paper sheets such as banknotes wherein the sheet is transported between a reference roller and a movable detection roller and which provide damping members.

**[0003]**

[Patent Literature 1] Japanese Patent Laid-Open No. 2014-102719

[Patent Literature 2] US 2005 056 575 A1

[Patent Literature 3] US 4 378 109 A1

[Patent Literature 4] JP 2000 357254 A

[Patent Literature 5] JP 2020 059559 A

**[0004]** In recent years, in a banknote identification apparatus, there has been adopted a configuration that is unitized by being divided into an upper unit and a lower unit with a conveyance path for banknotes therebetween, and is attached to be openable and closable with one end side in a banknote conveyance direction as a rotation axis of a hinge. A banknote thickness detection apparatus that is incorporated into the banknote identification apparatus with this configuration is also configured to be unitized with a plurality of reference rollers as a lower unit, and a plurality of detection rollers as an upper unit, and assembled to be openable and closable with one end side in

the banknote conveyance direction as a rotation axis. The openable and closable configuration like this has an advantage of providing high maintainability at a time of removing a jam of banknotes that occurs between the reference rollers and the detection rollers.

**[0005]** However, since in the openable and closable configuration like this, the upper unit is openable and closable and there is little restraint, it is not sufficient to suppress vibration of the detection rollers that occurs due to the impact at a time of the banknotes rushing in between the reference rollers and the detection rollers. If a space between the upper and lower rollers varies due to the vibration, the banknote thickness detection apparatus cannot correctly detect the thickness of banknotes.

**[0006]** The present invention is made in consideration of the above and has an object to enhance precision of thickness detection of paper sheets by suppressing vibration that occurs due to impact at a time of paper sheets rushing in between a reference roller and a detection roller, while ensuring maintainability, in a paper sheet thickness detection apparatus.

## SUMMARY OF THE INVENTION

**[0007]** In order to solve the above problem, according to the present invention a paper sheet thickness detection apparatus according to claim 1 is provided. Preferred embodiments are provided in the dependent claims.

**[0008]** According to the present invention, it is possible to enhance precision of thickness detection of a paper sheet by suppressing vibration that occurs due to impact at a time of the paper sheet rushing in between the reference roller and the detection roller while ensuring maintainability in the paper sheet thickness detection apparatus, for example.

## BRIEF DESCRIPTION OF THE DRAWINGS

**[0009]**

FIG. 1 is an appearance perspective view of an automatic cash transaction apparatus according to an embodiment;

FIG. 2 is a view showing an outline of an internal configuration of the automatic cash transaction apparatus according to the embodiment;

FIG. 3 is a side view of a banknote identification apparatus according to the embodiment;

FIG. 4 is a plan view of the banknote identification apparatus according to the embodiment;

FIG. 5 is a front view of the banknote identification apparatus according to the embodiment;

FIG. 6 is a plan view of a thickness detection apparatus according to the embodiment (state in which upper and lower units are closed);

FIG. 7 is a perspective view of the thickness detection apparatus according to the embodiment (state in which the upper and lower units are closed);

FIG. 8 is a front view of the thickness detection apparatus according to the embodiment (state in which the upper and lower units are closed);

FIG. 9 is a sectional side view of the thickness detection apparatus according to the embodiment (state in which the upper and lower units are closed);

FIG. 10 is a sectional side view of the thickness detection apparatus according to the embodiment (state in which the upper and lower units are opened);

FIG. 11 is a front view of the thickness detection apparatus according to the embodiment (state in which the upper and lower units are opened);

FIG. 12 is a graph showing a change of a thickness detection value due to vibration of a detection roller of a thickness detection apparatus of a comparative example in which a vibration damping member is not provided;

FIG. 13 is a graph showing a change of a thickness detection value due to vibration of a detection roller of a thickness detection apparatus of Example 1 in which a vibration damping member with a viscosity coefficient smaller than a predetermined value is pressed with a beam;

FIG. 14 is a graph showing a change of a thickness detection value due to vibration of a detection roller of a thickness detection apparatus of Example 2 in which a vibration damping member with a viscosity coefficient equal to or larger than a predetermined value is provided; and

FIG. 15 is a graph showing a change of a thickness detection value due to vibration of a detection roller of a thickness detection apparatus of Example 3 in which a vibration damping member with a viscosity coefficient equal to or larger than a predetermined value is pressed with a beam.

#### DETAILED DESCRIPTION OF THE PREFERRED EMBODIMENT

**[0010]** Hereinafter, an embodiment of the present invention will be described in detail based on the drawings. The following embodiment including the drawings is only illustration and does not limit the present invention. In each of the drawings for describing the following embodiment, the same reference signs denote components or processes including the same or similar functions, and explanation to be mentioned subsequently will be omitted. Further, respective embodiments, respective examples, and respective modified examples can be properly combined partially or entirely within a scope of a technical idea of the present invention and a coherent range.

**[0011]** In the following embodiment, a vertical direction (an upward direction, upward) of an apparatus enclosure of an automatic cash transaction apparatus is a positive direction of a Z axis, and a direction from a user side (a front side, a front) of the apparatus enclosure toward an

opposite side (a rear side, a back) is a positive direction of a Y axis. Further, a direction toward a right side from a left side toward a user side of the apparatus enclosure is a positive direction of an X axis. In explanation of the following embodiment, a positive XYZ coordinate system in which the X axis, Y axis and Z axis are orthogonal to each other is used.

**[0012]** In the following embodiment, directions and positions expressed by "up", "down", "left", "right", "front", "back", "rear" and the like are only relative, and orientations, shapes, or sizes of the automatic cash transaction apparatus and components thereof are not limited by the XYZ coordinate system. Further, the numbers of components in explanation and illustration of the embodiment are only examples.

**[0013]** In the following embodiment, as examples of a paper sheet thickness detection apparatus, a paper sheet identification apparatus, a paper sheet handling apparatus, and an automatic paper sheet transaction apparatus, a banknote thickness detection apparatus, a banknote identification apparatus, a banknote handling apparatus, and an automatic cash transaction apparatus that handle with banknotes as paper sheets will be described as examples. However, it is possible to handle with various other paper sheets such as checks and gift certificates similarly without being limited to this.

(Entire Configuration of Automatic Cash Transaction Apparatus 1)

**[0014]** FIG. 1 is an appearance perspective view of an automatic cash transaction apparatus 1 according to the embodiment. The automatic cash transaction apparatus 1 uses cash cards, banknotes, statements and the like as transaction media, and performs processes such as cash deposits, payments, and transfers by user operations. At an upper part in the apparatus enclosure of the automatic cash transaction apparatus 1, a passbook processing mechanism (not illustrated) that processes a passbook of a user, prints transaction details and releases the passbook, and a card and statement processing mechanism (not illustrated) that processes a card of a user, prints a transaction statement and releases them are included.

**[0015]** The passbook processing mechanism processes a passbook of a user inserted through a slot 2 on a front of the automatic cash transaction apparatus 1, and prints transaction details to release the passbook. The card and statement processing mechanism processes a card of a user inserted through a slot 3 on the front of the automatic cash transaction apparatus, and prints a transaction statement to release the transaction statement with the card. In front of the front of the automatic cash transaction apparatus 1, there is included a screen operation section 4 for displaying contents of a transaction by a user and for inputting various kinds of information and items for transaction.

**[0016]** At a lower part in the apparatus enclosure of the automatic cash transaction apparatus 1, a banknote

handling apparatus 10 that processes banknotes is included. Deposit/withdrawal transactions of banknotes are performed according to opening and closing of a shutter 5a provided in a deposit/withdrawal section 5 of the banknote handling apparatus 10.

**[0017]** Note that in the apparatus enclosure of the automatic cash transaction apparatus 1, a coin processing apparatus (not illustrated) that processes coins may be included. Deposit/withdrawal transactions of coins are performed according to opening and closing of a shutter (not illustrated) provided at a deposit/withdrawal section of the coin processing apparatus.

(Internal Configuration of Automatic Cash Transaction Apparatus 1)

**[0018]** FIG. 2 is a view showing an outline of an internal configuration of the automatic cash transaction apparatus 1 according to the embodiment. In an upper part of the enclosure lower part of the automatic cash transaction apparatus 1, a processing mechanism of banknotes to be transacted is placed, and in a lower part, a storage mechanism of banknotes is placed. In the upper part of the enclosure lower part of the banknote handling apparatus 10, at a front side thereof (side facing a user: an upper right side in FIG. 2), the deposit/withdrawal section 5 is placed, which receives deposit of banknotes set in a substantially standing position by a user, and sets banknotes in a substantially standing position to release the banknotes and allow a user to take out the banknotes. In the deposit/withdrawal section 5, a banknote delivery section 5b that delivers banknotes inserted from above downward, and a banknote accumulation section 5c that accumulates banknotes for withdrawal or return that are conveyed from below are placed one behind the other.

**[0019]** Further, a banknote identification apparatus 30 that distinguishes banknotes is placed in a center part, and at a rear side (upper left side in FIG. 2), a temporary storage section 40 is disposed, which temporarily stores banknotes deposited by a user until a transaction is established. Each of these mechanism sections are connected by a bi-directional conveyance path.

**[0020]** The banknote identification apparatus 30 can perform denomination discrimination and authenticity discrimination of banknotes conveyed on a conveyance path 30a from the front and the back from either direction. The banknote identification apparatus 30 can discriminate the denomination and authenticity of banknotes that are conveyed in both directions of deposit and withdrawal, and can discriminate whether or not the banknotes can be accepted and whether the banknotes can be dispensed.

**[0021]** In the lower part of the banknote handling apparatus 10, a plurality of storage units 70 that store banknotes by denomination are disposed. Some of the storage units 70 store banknotes that are determined to be acceptable in the banknote identification apparatus 30 by denomination. In addition, among the storage units 70,

there is a storage unit 70 that temporarily stores banknotes that are determined as unacceptable in the banknote identification apparatus 30, a storage unit 70 that stores banknotes that are determined not to be withdrawable in the banknote identification apparatus 30, and a storage unit 70 that is used when banknotes are replenished from outside for withdrawal.

(Appearance Configuration of Banknote Identification Apparatus 30)

**[0022]** With reference to FIG. 3 to FIG. 5, an appearance configuration of the banknote identification apparatus 30 according to the embodiment will be described. FIG. 3 is a side view of the banknote identification apparatus 30 according to the embodiment seen from an X axis negative direction side, FIG. 4 is a plan view of the banknote identification apparatus 30 according to the embodiment seen from a Z axis positive direction side, and FIG. 5 is a front view of the banknote identification apparatus 30 according to the embodiment seen from a Y axis negative direction side.

**[0023]** The banknote identification apparatus 30 has an upper unit 30U in which components located above the conveyance path 30a are unitized, and a lower unit 30L in which components located below the conveyance path 30a are unitized, with the conveyance path 30a for banknotes therebetween. The banknote identification apparatus 30 is configured such that the upper unit 30U is attached at one end side (Y axis positive direction side) in the conveyance direction of banknotes to be openable and closable with respect to the lower unit 30L, with a rotation axis 30X parallel with the X axis as a rotation center. The upper unit 30U is openable in an arrow A (FIG. 3) direction around the rotation axis 30X.

**[0024]** Further, the banknote identification apparatus 30 includes a thickness detection apparatus 30T (FIG. 6 to FIG. 11) that detects a thickness of a banknote conveyed on the conveyance path 30a, in an inside in a vicinity of the rotation axis 30X (an area 30Z1 in FIG. 3, a vicinity of area 30Z2 in FIG. 4).

(Configuration of Thickness Detection Apparatus 30T)

**[0025]** With reference to FIG. 6 to FIG. 11, a configuration of the thickness detection apparatus 30T according to the embodiment will be described. FIG. 6 is a plan view of the thickness detection apparatus 30T according to the embodiment seen from a Z axis positive direction side. FIG. 7 is a perspective view of the thickness detection apparatus 30T according to the embodiment (state in which the upper and lower units are closed). FIG. 8 is a front view of the thickness detection apparatus 30T according to the embodiment seen from the Y axis positive direction side (state in which the upper and lower units are closed). FIG. 9 is a sectional side view of the thickness detection apparatus 30T according to the embodiment seen from an X axis negative direction side (state in

which the upper and lower units are closed). FIG. 10 is a sectional side view of the thickness detection apparatus 30T according to the embodiment seen from the X axis negative direction side (state in which the upper and lower units are opened). FIG. 11 is a front view of the thickness detection apparatus 30T according to the embodiment seen from a Y axis positive direction (state in which the upper and lower units are opened).

**[0026]** The plan view of the thickness detection apparatus 30T in FIG. 6 is a drawing in which illustration of the elements other than the thickness detection apparatus 30T is omitted in the plan view of the banknote identification apparatus 30 in FIG. 4. Further, the sectional side view of the thickness detection apparatus 30T in FIG. 9 is a drawing in which illustration of the elements other than the thickness detection apparatus 30T is omitted in the side view of the banknote identification apparatus 30 in FIG. 3.

**[0027]** As shown in FIG. 6 and FIG. 7, the thickness detection apparatus 30T includes a bracket 31, a sensor substrate 32, a vibration damping member 33, a beam 34, a reference roller 35, a reference roller shaft 35X, a detection roller 36, a detection roller shaft 36X, and an enclosure 37.

**[0028]** The enclosure 37 includes enclosures 37UR and 37UL on an upper unit 30U side of the banknote identification apparatus 30, and enclosures 37LR and 37LL on a lower unit 30L side. The enclosures 37UR and 37LR form an end surface on an X axis positive direction side of the thickness detection apparatus 30T. The enclosures 37UL and 37LL form an end surface on the X axis negative direction side of the thickness detection apparatus 30T.

**[0029]** The enclosures 37UR and 37UL are perpendicularly attached to the beam 34 respectively from both ends in the X axis direction, of the beam 34. The bracket 31 is installed on and between the enclosures 37UR and 37UL, and supports the sensor substrate 32 on which a thickness sensor is placed as described later so that the thickness sensor faces the detection roller 36. Further, on the bracket 31, the vibration damping member 33 is provided as described later. The bracket 31, the sensor substrate 32, the vibration damping member 33, the beam 34, the detection roller 36, the detection roller shaft 36X, and the enclosures 37UR and 37UL configure an upper unit 30TU (FIG. 7) of the thickness detection apparatus 30T. The reference roller 35 and the reference roller shaft 35X configure a lower unit 30TL (FIG. 7) of the thickness detection apparatus 30T.

**[0030]** The reference roller shaft 35X is a rotating shaft to which a rotational drive force is transmitted from a conveyance drive system (not illustrated) of a banknote conveyance mechanism, and is installed in and between the enclosures 37LR and 37LL along a width direction (X axis direction) of the conveyance path. The detection roller shaft 36X is installed in and between the enclosures 37LR and 37LL so as to face an upper side (Z axis positive direction) of the reference roller shaft 35X.

**[0031]** A plurality of reference rollers 35 are placed on the reference roller shaft 35X on a lower side. Further, the same number of the detection rollers 36 as the number of the reference rollers 35 are disposed on the detection roller shaft 36X on an upper side to face the respective reference rollers 35.

**[0032]** The detection roller 36 is configured by an outer ring formed of a cylindrical inelastic member such as metal an outer peripheral surface of which is not displaced, and an elastic member such as a spring or rubber that is elastically deformable in a direction to be pressed against the reference roller 35.

**[0033]** The reference roller 35 is formed of metal, is provided with an outer surface as a reference surface that is not displaced, and each of the detection rollers 36 is faced to contact the reference surface. Subsequently, the respective detection rollers 36 are driven to rotate while being respectively pressed against the corresponding reference rollers 35. Further, when a banknote is sandwiched between the detection roller 36 and the reference roller 35, the outer ring of the detection roller 36 that faces the outer peripheral surface of the reference roller 35 as the reference surface is displaced in an upward direction (Z axis positive direction toward the detection roller shaft 36X from the reference roller shaft 35X) according to a thickness of the banknote.

**[0034]** Above (Z axis positive direction) of the plurality of detection rollers 36, the sensor substrate 32 is provided, in which the thickness sensor (not illustrated) that is placed to face the respective detection rollers 36, and a sensor processing unit (not illustrated) that processes data obtained from the thickness sensor (not illustrated) are disposed. The thickness sensor is, for example, an eddy current magnetic field type displacement sensor that can detect a displacement amount by which the facing detection roller 36 elastically displaces in an up-down direction (Z axis direction) according to the thickness of a banknote sandwiched by the facing detection roller 36 with the reference roller 35. The sensor substrate 32 is supported by the bracket 31 so that the thickness sensor faces the detection rollers 36. The thickness detection apparatus 30T detects a thickness of a banknote based on the displacement amount of the detection roller 36 detected by the thickness sensor.

**[0035]** The vibration damping member 33 is a member in a long shape that is provided on the bracket 31 to extend in a width direction (X axis direction) of the conveyance path 30a, but the shape is not limited to a long shape. The vibration damping member 33 is a viscoelastic member, but is not limited to a viscoelastic member. A plurality of vibration damping members 33 are stacked in layers in the Z axis positive direction toward the beam 34, onto the bracket 31, but the vibration damping member 33 may be in a single layer. The vibration damping member 33 is a damper that suppresses vibration of the detection rollers 36 that occurs due to impact at a time of banknotes rushing in between the reference rollers 35 and the detection rollers 36.

**[0036]** When the vibration damping member 33 is pressed by a pressing member having higher rigidity than the vibration damping member 33, an initial amplitude of the detection roller 36 is suppressed, and a vibration damping time period is shortened. When an existing member can be used as the pressing member, vibration damping by the vibration damping member 33 becomes more effective by filling a space between a placement surface of the vibration damping member 33 and the pressing member with the vibration damping member 33. In the present embodiment, as shown in FIG. 7, the vibration damping effect is enhanced by using the beam 34 as the pressing member, and stacking the vibration damping members 33 in layers in the Z axis positive direction on the bracket 31 up to the beam 34 to fill the space. The pressing member that presses the vibration damping member 33 may be newly provided, but by using the existing member like the beam 34, it is possible to enhance the vibration damping effect of the vibration damping member 33 without increasing the number of components.

**[0037]** The vibration damping effect can be obtained even if the vibration damping member 33 is placed in any place in the upper unit 30TU without being limited to modes shown in FIG. 7 to FIG. 9, as long as the vibration damping member 33 is in a positional relationship in which the vibration damping member 33 viscously deforms in a vibration direction (or a vibration damping direction) of the detection roller 36.

**[0038]** When the upper unit 30U of the banknote identification apparatus 30 is rotationally moved in the arrow A direction with respect to the lower unit 30L with the rotation axis 30X as the center, as shown in FIG. 3, the upper unit 30TU of the thickness detection apparatus 30T rotationally moves in the arrow A direction with respect to the lower unit 30TL (FIG. 10). The upper unit 30TU includes the enclosures 37UR and 37UL, the bracket 31, the sensor substrate 32, the vibration damping member 33, and the beam 34. The lower unit 30TL includes the enclosures 37LR and 37LL, and the reference roller shaft 35X. FIG. 11 is a front view of the thickness detection apparatus 30T in a state in which the upper and lower units shown in FIG. 10 are opened seen from the Y axis positive direction.

(Vibration Damping Effect of Detection Roller 36 by Vibration Damping Member 33)

**[0039]** A vibration damping effect of the detection roller 36 by the vibration damping member 33 according to the embodiment will be described with reference to FIG. 12 to FIG. 15. FIG. 10 to FIG. 15 each shows a time change of a thickness detection value due to vibration of the detection roller 36 at a time of conveying a banknote with a predetermined thickness, with a time point taken on a horizontal axis, and the thickness detection value of the detection roller 36 taken on a vertical axis.

**[0040]** First, as a comparative example, a time change

of vibration of a detection roller 36 in a case where a vibration damping member 33 is not provided in a thickness detection apparatus 30T will be described. FIG. 12 is a graph showing a change of the thickness detection value due to vibration of the detection roller 36 of the thickness detection apparatus 30T of the comparative example in which the vibration damping member 33 is not provided.

**[0041]** As shown in FIG. 12, the detection value of a thickness sensor attached to a sensor substrate 32 vibrated due to vibration of the detection roller 36 that occurred at a time point  $t=0$ , and a time period until a time point  $t=t_5$  was required for the vibration to converge within a predetermined range, as indicated by a circle in FIG. 12.

**[0042]** Next, as example 1, a time change of vibration of a detection roller 36 in a case of pressing a vibration damping member 33 with a viscosity coefficient smaller than a predetermined value with a beam 34 in a thickness detection apparatus 30T will be described. FIG. 13 is a graph showing a change of a thickness detection value due to vibration of the detection roller 36 of the thickness detection apparatus 30T of example 1 in which the vibration damping member 33 with the viscosity coefficient smaller than the predetermined value was pressed with the beam 34.

**[0043]** As shown in FIG. 13, the detection value of a thickness sensor attached to a sensor substrate 32 vibrated due to vibration of the detection roller 36 that occurred at a time point  $t=0$ , and a time period until about a time point  $t=t_2$  was required for the vibration to converge within a predetermined range as indicated by a circle in FIG. 13. In Example 1, an amplitude of an initial vibration at a time point  $t=0$  was suppressed and a vibration converging time period was shorter, as compared with the comparative example. In Example 1, the vibration damping member 33 pressed by the beam 34 can be said as functioning as a reinforcement member that suppresses vibration.

**[0044]** Next, as example 2, a time change of vibration of a detection roller 36 in a case of a vibration damping member 33 with a viscosity coefficient equal to or larger than a predetermined value being provided in a thickness detection apparatus 30T will be described. FIG. 14 is a graph showing a change of a thickness detection value due to the vibration of the detection roller 36 of the thickness detection apparatus 30T of example 2 in which the vibration damping member 33 with the viscosity coefficient equal to or larger than the predetermined value is provided.

**[0045]** As shown in FIG. 14, a detection value of a thickness sensor attached to a sensor substrate 32 vibrated due to vibration of the detection roller 36 that occurred at a time point  $t=0$ , and a time period until about a time point  $t=t_1$  was required for the vibration to converge within a predetermined range, as indicated by a circle in FIG. 14. In Example 2, an amplitude is larger but a converging time period of the vibration is further shorter

than in Example 1. In Example 2, the vibration damping member 33 can be said as functioning as a damper that absorbs vibration.

**[0046]** Next, as Example 3, a time change of vibration of a detection roller 36 in a case of pressing a vibration damping member 33 with a viscosity coefficient equal to or larger than a predetermined value, with a beam 34 in a thickness detection apparatus 30T will be described. FIG. 15 is a graph showing a change of a thickness detection value due to vibration of the detection roller 36 of the thickness detection apparatus 30T in Example 3 in which the vibration damping member 33 with the viscosity coefficient equal to or larger than the predetermined value was pressed with the beam 34.

**[0047]** As shown in FIG. 15, a detection value of a thickness sensor attached to a sensor substrate 32 vibrated due to vibration of the detection roller 36 that occurred at a time point  $t=0$ . A time period until about a time point  $t=(t/2)$  was required for the vibration to converge within a predetermined range as indicated by a circle in FIG. 15. In Example 3, the converging time period of the vibration is further shorter than in Example 2. It can be said that in Example 3, the vibration damping member 33 has a viscosity coefficient equal to or larger than the predetermined value, and damper performance of absorbing vibration is further enhanced by pressing the vibration damping member 33 with the beam 34 having higher rigidity than the vibration damping member 33.

**[0048]** From the above, the vibration damping member 33 has higher damper performance for absorbing vibration, and converges the vibration of the detection roller 36 in a shorter time period, in order of Example 3, Example 2, and Example 1. Therefore, according to these examples, it is possible to enhance precision of thickness detection of banknotes by suppressing vibration of the detection roller 36 that occurs due to impact at the time of the banknotes rushing in between the reference roller 35 and the detection roller 36. Further, even with the configuration in which the banknote identification apparatus 30 and the thickness detection apparatus 30T are divided into the upper units 30U and 30TU, and the lower units 30L and 30LT, and attached to be openable and closable, it is possible to suppress vibration of the detection roller 36. Therefore, it is possible to achieve compatibility with maintainability at a time of removing a jam of banknotes that occurs between the reference roller 35 and the detection roller 36.

**[0049]** Note that the present invention is not limited to the aforementioned embodiment, but includes various modified examples. For example, the aforementioned embodiment is described in detail to make the present invention easy to understand, and the present invention is not necessarily limited to the embodiment including all the configurations that are described. As long as there is no contradiction, it is possible to replace part of the configuration of one embodiment with the configuration of another embodiment, or to add the configuration of another embodiment to the configuration of one embodi-

ment. Further, it is possible to perform addition, deletion, replacement, integration, and division with respect to part of the configuration of each embodiment. Each process shown in the embodiment may be properly distributed or integrated based on processing efficiency or implementation efficiency.

**[0050]** The scope of the invention is defined by the appended claims.

#### 10 Reference Signs List

**[0051]** 1: Automatic cash transaction apparatus, 10: Banknote handling apparatus, 30: Banknote identification apparatus, 30T: Thickness detection apparatus, 30L: Lower unit, 30U: Upper unit, 30TL: Lower unit (first unit), 30TU: Upper unit (Second unit), 30a: Conveyance path, 31: Bracket, 32: Sensor substrate, 33: Vibration damping member, 34: Beam, 35: Reference roller, 36: Detection roller, 37, 37LR, 37LL, 37UR, 37UL: Enclosure

#### 20 Claims

1. A paper sheet thickness detection apparatus (30) configured to detect a thickness of a paper sheet, comprising:

a first unit (30TL) including a reference roller (35); and

a second unit (30TU) including a detection roller (36) configured to sandwich the paper sheet with the reference roller (35) to convey the paper sheet and to displace with respect to the reference roller (35) according to a thickness of the paper sheet, and a thickness sensor (30T) configured to detect the thickness of the paper sheet based on a displacement amount of the detection roller (36), wherein

the first unit (30TL) and the second unit (30TU) are superposed such that the reference roller (35) and the detection roller (36) sandwich the paper sheet to form a conveyance path (30a) for the paper sheet, and are assembled to be openable and closable with a rotation axis (30X) provided on one end side of the conveyance path (30a) as a center, and the second unit (30TU) comprises a vibration damping member (33) on the thickness sensor (30T),

#### 50 characterised in that

the vibration damping member (33) is configured to viscously deform in a vibration damping direction for damping vibration of the detection roller (36),

wherein the second unit (30TU) comprises a bracket (31) configured to support the thickness sensor (30T) so that the thickness sensor (30T) faces the detection roller (36), and

the vibration damping member (33) is placed on the bracket (31),

a pressing member (34) configured to press the vibration damping member (33) with a placement surface of the vibration damping member (33), and has higher rigidity than the vibration damping member (33).

2. The paper sheet thickness detection apparatus (30) according to claim 1, wherein a viscosity coefficient of the vibration damping member (33) is equal to or larger than a predetermined value.

3. The paper sheet thickness detection apparatus (30) according to claim 2, wherein

the pressing member (34) is an existing member of the second unit (30TU) which has a function other than pressing the vibration damping member (33), and

the vibration damping member (33) is filled in a space from the placement surface to the pressing member (34).

4. A paper sheet identification apparatus including the paper sheet thickness detection apparatus (30) according to any one of claims 1 to 3.

5. A paper sheet handling apparatus including the paper sheet identification apparatus according to claim 4.

#### Patentansprüche

1. Vorrichtung (30) zum Detektieren einer Papierbogendicke, die konfiguriert ist, die Dicke eines Papierbogens zu detektieren, wobei die Vorrichtung Folgendes umfasst:

eine erste Einheit (30TL), die eine Referenzwalze (35) umfasst; und

eine zweite Einheit (30TU), die Folgendes umfasst: eine Detektionswalze (36), die konfiguriert ist, den Papierbogen zwischen dieser und der Referenzwalze (35) anzuordnen, um den Papierbogen zu transportieren, und sich in Bezug auf die Referenzwalze (35) entsprechend einer Dicke des Papierbogens zu verlagern, und einen Dickensensor (30T), der konfiguriert ist, die Dicke des Papierbogens auf der Basis eines Verlagerungsbetrags der Detektionswalze (36) zu detektieren, wobei

die erste Einheit (30TL) und die zweite Einheit (30TU) übereinander angeordnet sind, so dass der Papierbogen zwischen der Referenzwalze (35) und der Detektionswalze (36) angeordnet

ist, um einen Transportpfad (30a) für den Papierbogen zu bilden, und so zusammengebaut sind, dass sie geöffnet und geschlossen werden können, wobei eine Drehachse (30X) an einer Stirnseite des Transportpfads (30a) als Zentrum vorgesehen ist, und

die zweite Einheit (30TU) ein Schwingungsdämpfungselement (33) am Dickensensor (30T) umfasst,

**dadurch gekennzeichnet, dass**

das Schwingungsdämpfungselement (33) so konfiguriert ist, dass es sich in einer Schwingungsdämpfungsrichtung viskos verformt, um eine Schwingung der Detektionswalze (36) zu dämpfen,

wobei die zweite Einheit (30TU) eine Halterung (31) umfasst, die konfiguriert ist, den Dickensensor (30T) so zu tragen, dass der Dickensensor (30T) zur Detektionswalze (36) zeigt, und das Schwingungsdämpfungselement (33) an der Halterung (31) angeordnet ist,

ein Presselement (34) konfiguriert ist, auf das Schwingungsdämpfungselement (33) mit einer Anordnungsfläche des Schwingungsdämpfungselements (33) zu pressen, und eine höhere Steifigkeit als das Schwingungsdämpfungselement (33) aufweist.

2. Vorrichtung (30) zum Detektieren einer Papierbogendicke nach Anspruch 1, wobei ein Viskositätskoeffizient des Schwingungsdämpfungselements (33) gleich einem zuvor festgelegten Wert oder größer ist.

3. Vorrichtung (30) zum Detektieren einer Papierbogendicke nach Anspruch 2, wobei

das Presselement (34) ein existierendes Element der zweiten Einheit (30TU) ist, das eine weitere Funktion neben dem Pressen auf das Schwingungsdämpfungselement (33) hat, und das Schwingungsdämpfungselement (33) in einen Raum vor der Anordnungsfläche des Presselements (34) eingesetzt ist.

4. Papierbogen-Identifikationsvorrichtung, die die Vorrichtung (30) zum Detektieren einer Papierbogendicke nach einem der Ansprüche 1 bis 3 umfasst.

5. Papierbogen-Handhabungsvorrichtung, die die Papierbogen-Identifikationsvorrichtung nach Anspruch 4 umfasst.

#### Revendications

1. Appareil de détection d'épaisseur de feuille de papier (30) configuré pour détecter une épaisseur

d'une feuille de papier, comprenant :

une première unité (30TL) incluant un rouleau de référence (35) ; et  
 une seconde unité (30TU) incluant un rouleau de détection (36) configuré pour prendre en sandwich la feuille de papier avec le rouleau de référence (35) afin de convoier la feuille de papier et de la déplacer par rapport au rouleau de référence (35) en accord avec une épaisseur de la feuille de papier, et un capteur d'épaisseur (30T) configuré pour détecter l'épaisseur de la feuille de papier sur la base d'une amplitude de déplacement du rouleau de détection (36), dans lequel  
 la première unité (30TL) et la seconde unité (30TU) sont superposées de telle sorte que le rouleau de référence (35) et le rouleau de détection (36) prennent en sandwich la feuille de papier pour former un trajet de convoyage (30a) pour la feuille de papier, et sont assemblés de façon à s'ouvrir et se fermer avec un axe de rotation (30X) prévu sur un côté d'extrémité du trajet de convoyage (30a) à titre de centre, et la seconde unité (30TU) comprend un élément amortisseur de vibration (33) sur le capteur d'épaisseur (30T),  
**caractérisé en ce que**  
 l'élément amortisseur de vibration (33) est configuré pour se déformer visqueusement dans une direction d'amortissement des vibration pour amortir une vibration du rouleau de détection (36),  
 dans lequel la seconde unité (30TU) comprend une monture (31) configurée pour supporter le capteur d'épaisseur (30T) de telle sorte que le capteur d'épaisseur (30T) fait face au rouleau de détection (36), et  
 l'élément amortisseur de vibration (33) est placé sur la monture (31),  
 un élément de pressage (34) est configuré pour presser l'élément amortisseur de vibration (33) avec une surface de placement de l'élément amortisseur de vibration (33), et a une rigidité supérieure à celle de l'élément amortisseur de vibration (33).

2. Appareil de détection d'épaisseur de feuille de papier (30) selon la revendication 1, dans lequel un coefficient de viscosité de l'élément amortisseur de vibration (33) est égal ou supérieur à une valeur prédéterminée.
3. Appareil de détection d'épaisseur de feuille de papier (30) selon la revendication 2, dans lequel l'élément de pressage (34) est un élément existant de la seconde unité (30TU) qui a une

fonction autre que celle de presser l'élément amortisseur de vibration (33), et l'élément amortisseur de vibration (33) est rempli dans un espace depuis la surface de placement jusqu'à l'élément de pressage (34).

4. Appareil d'identification de feuille de papier incluant l'appareil de détection d'épaisseur de feuille de papier (30) selon l'une quelconque des revendications 1 à 3.
5. Appareil de manutention de feuille de papier incluant l'appareil d'identification de feuille de papier selon la revendication 4.

FIG. 1

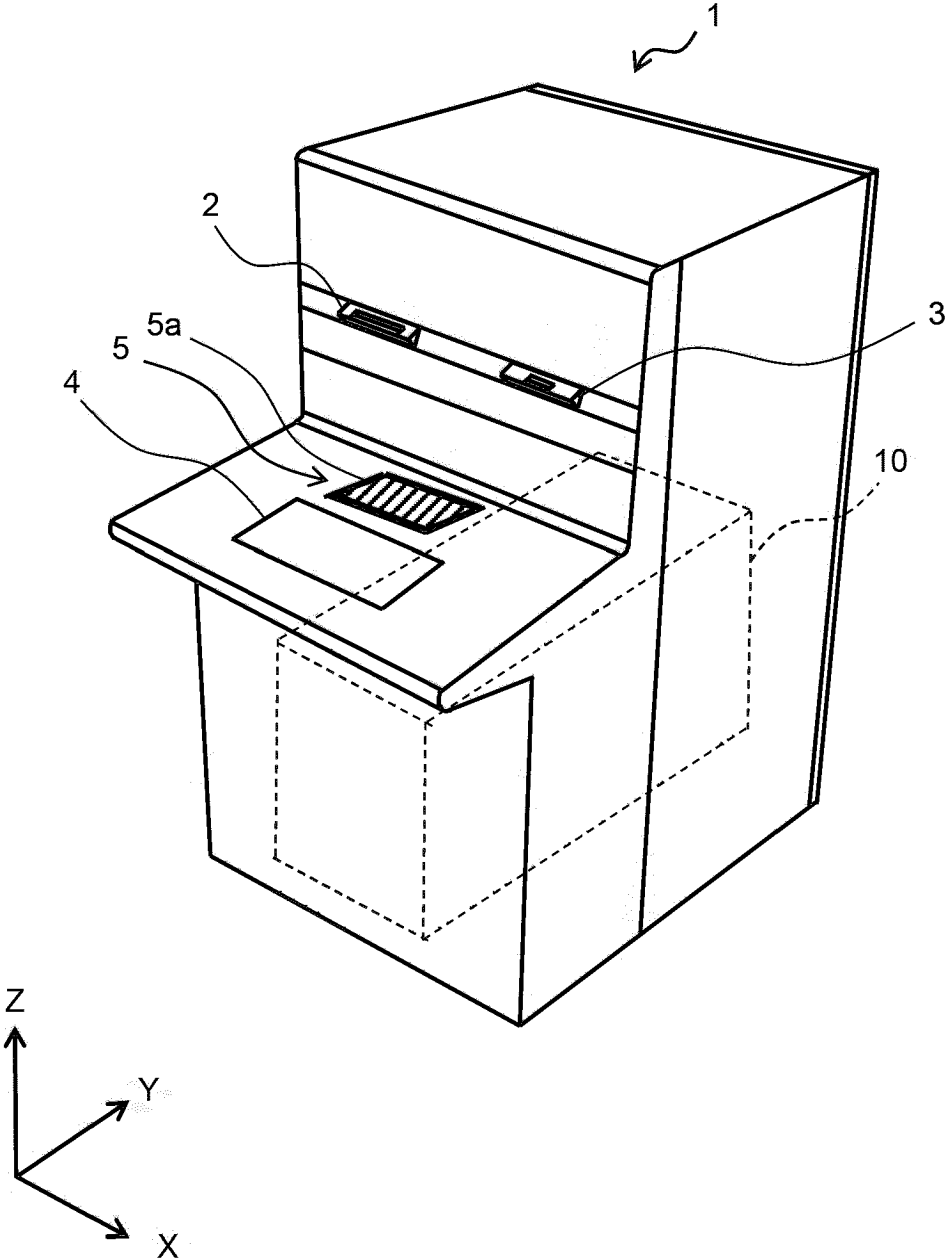

FIG. 2

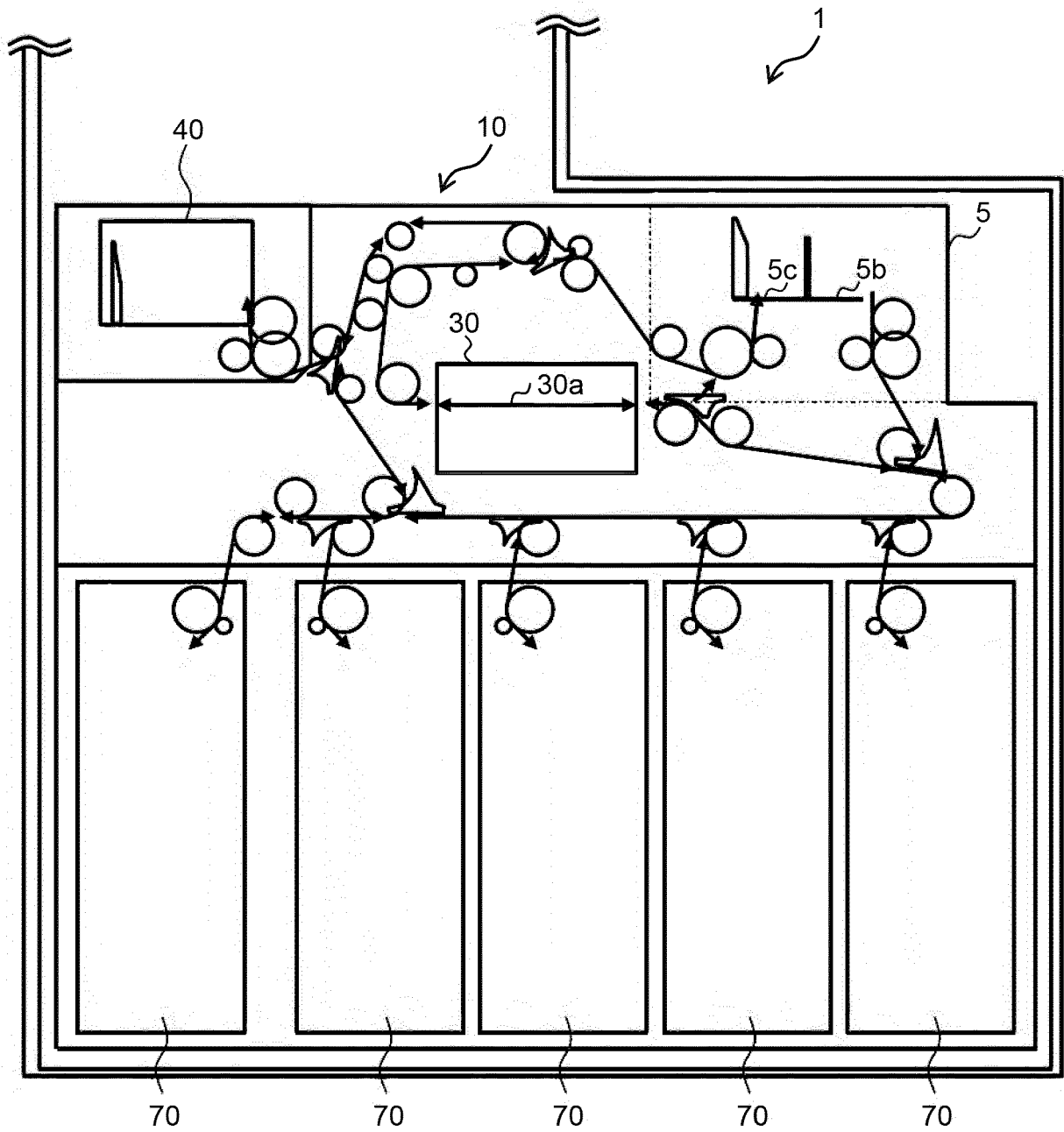

FIG. 3

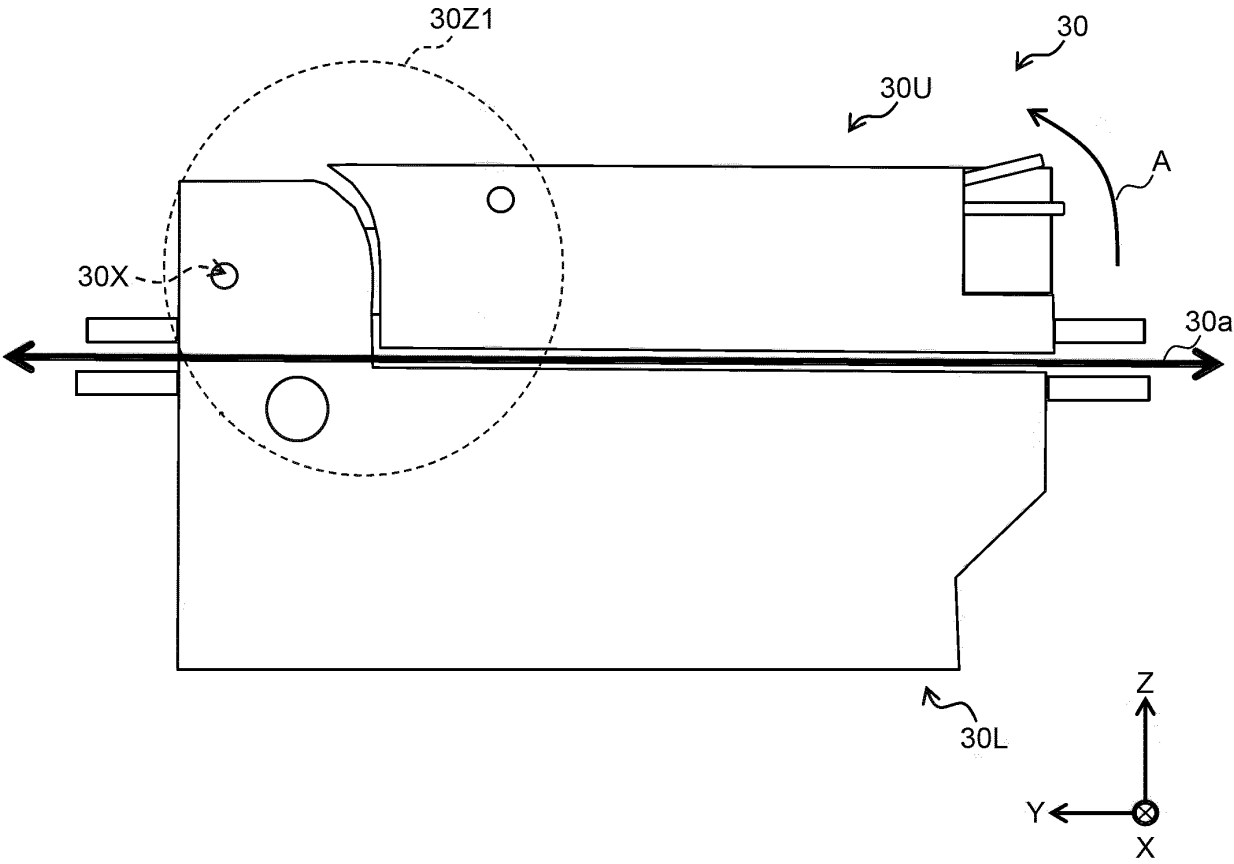

FIG. 4

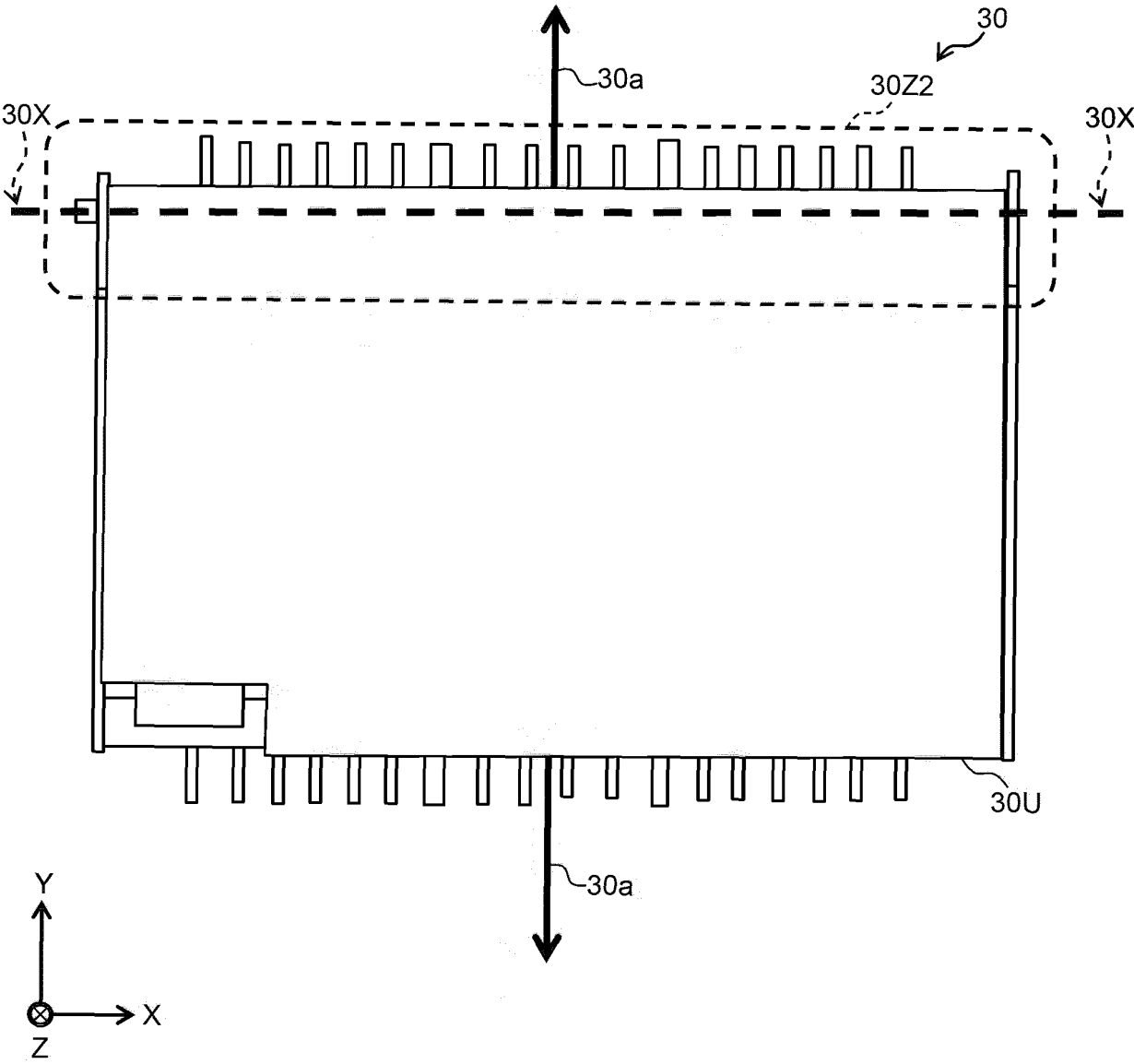

FIG. 5

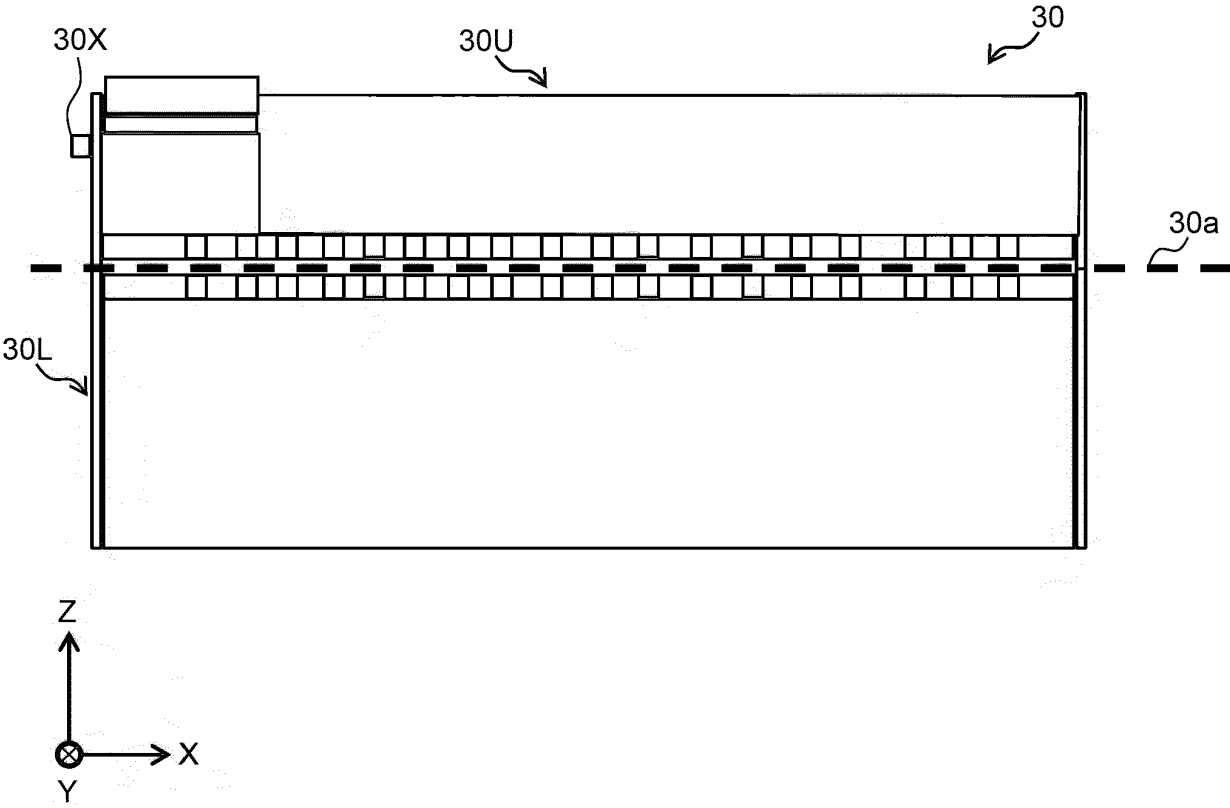

FIG. 6

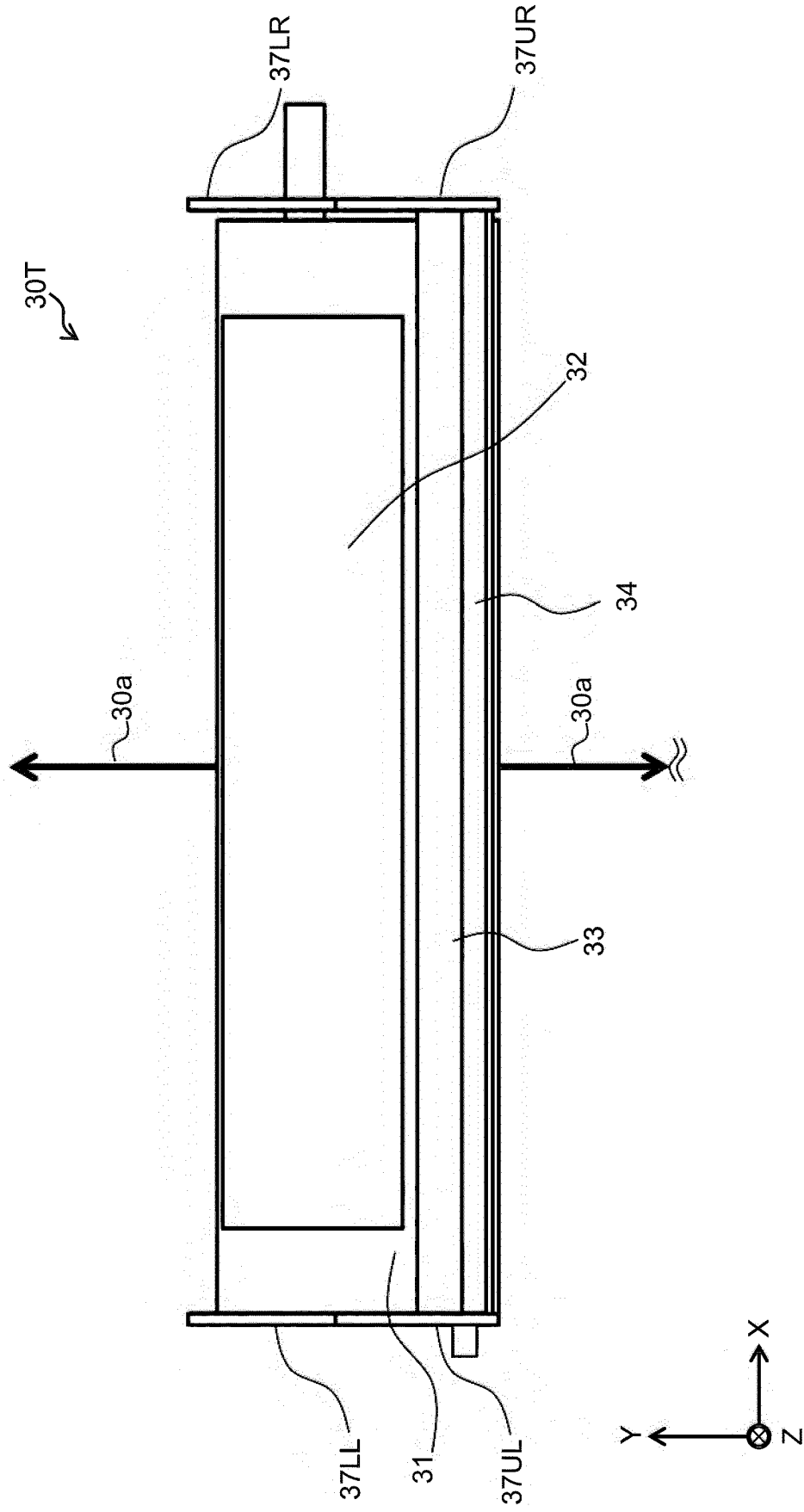

FIG. 7

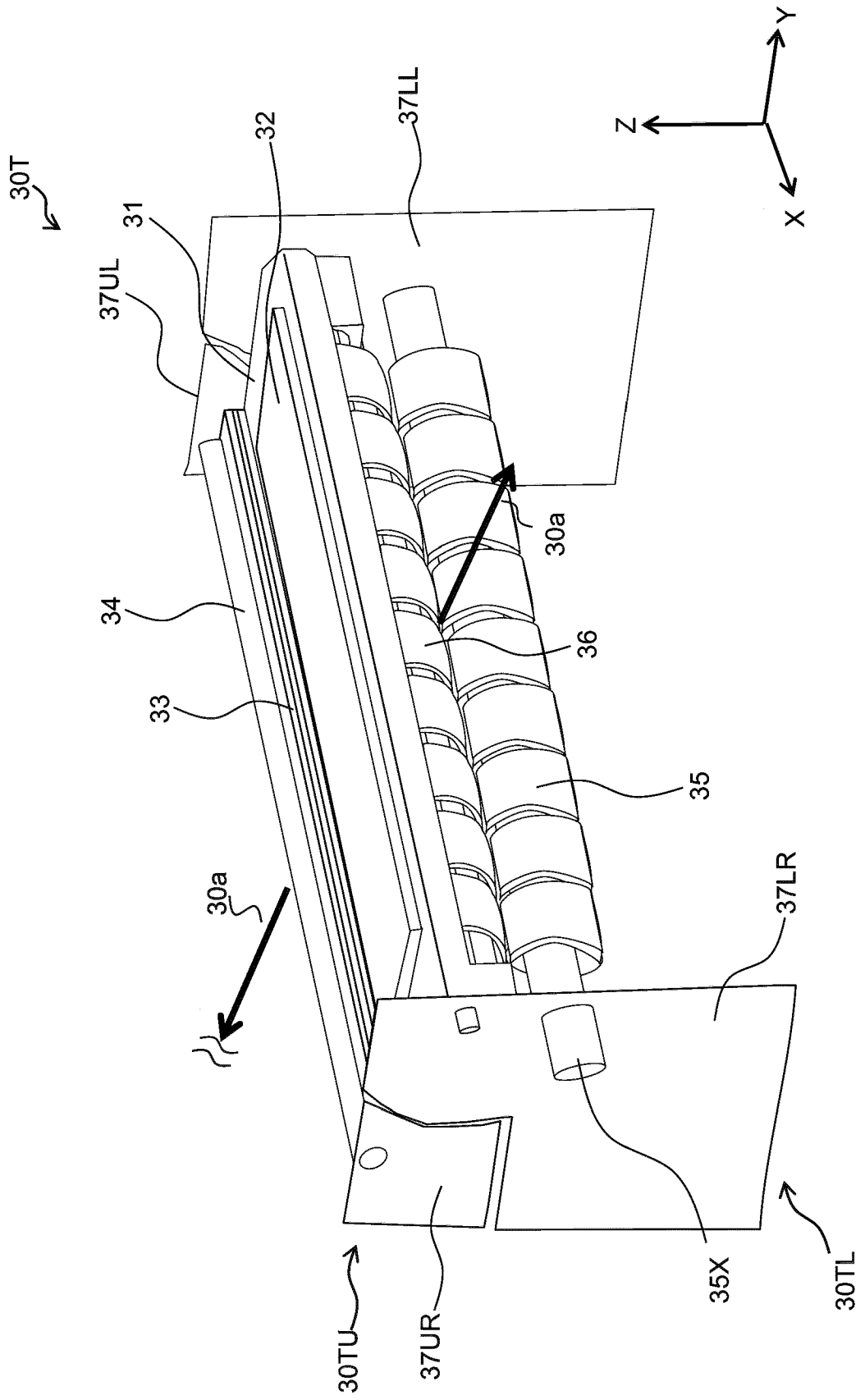

FIG. 8

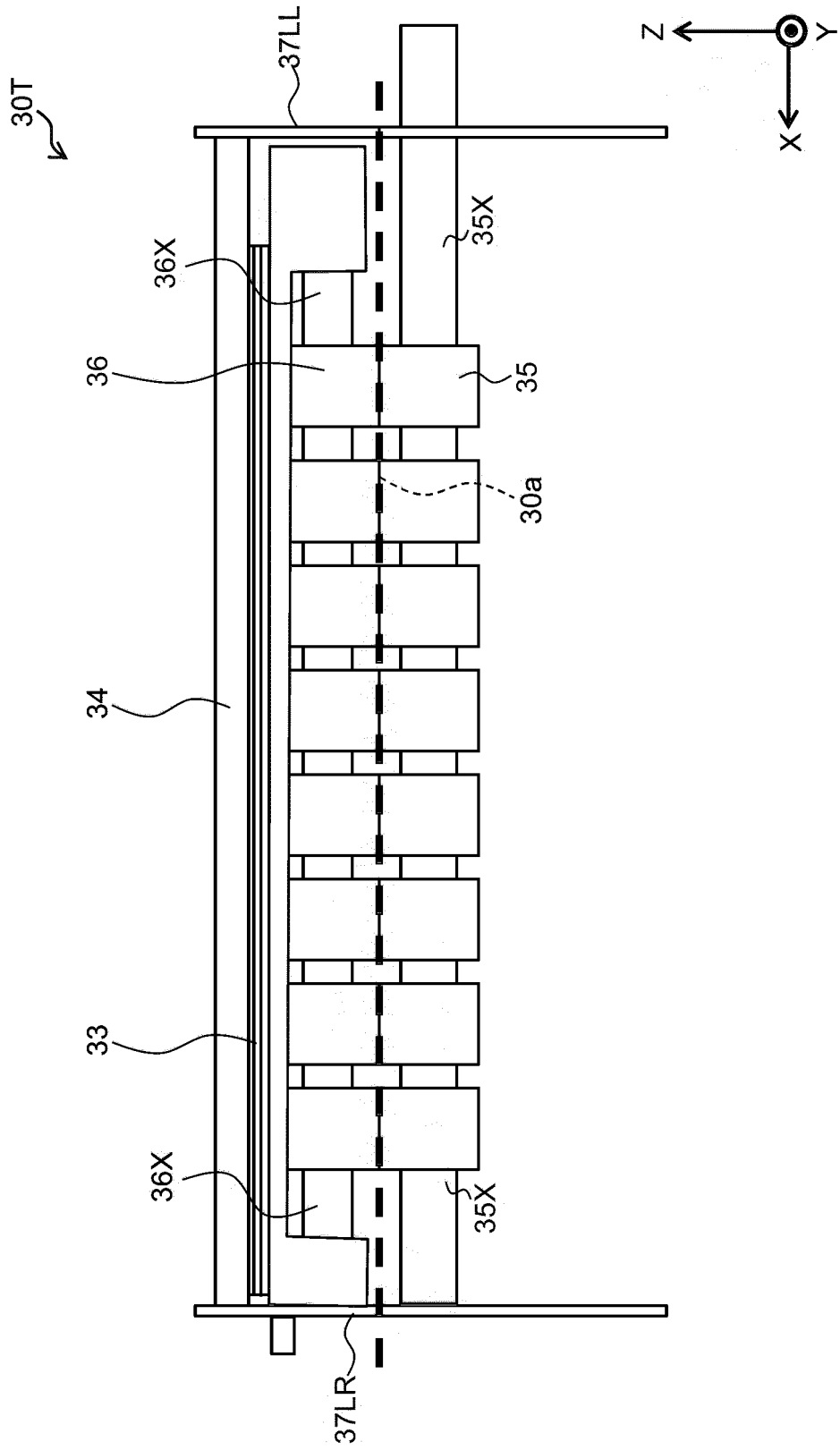

FIG. 9

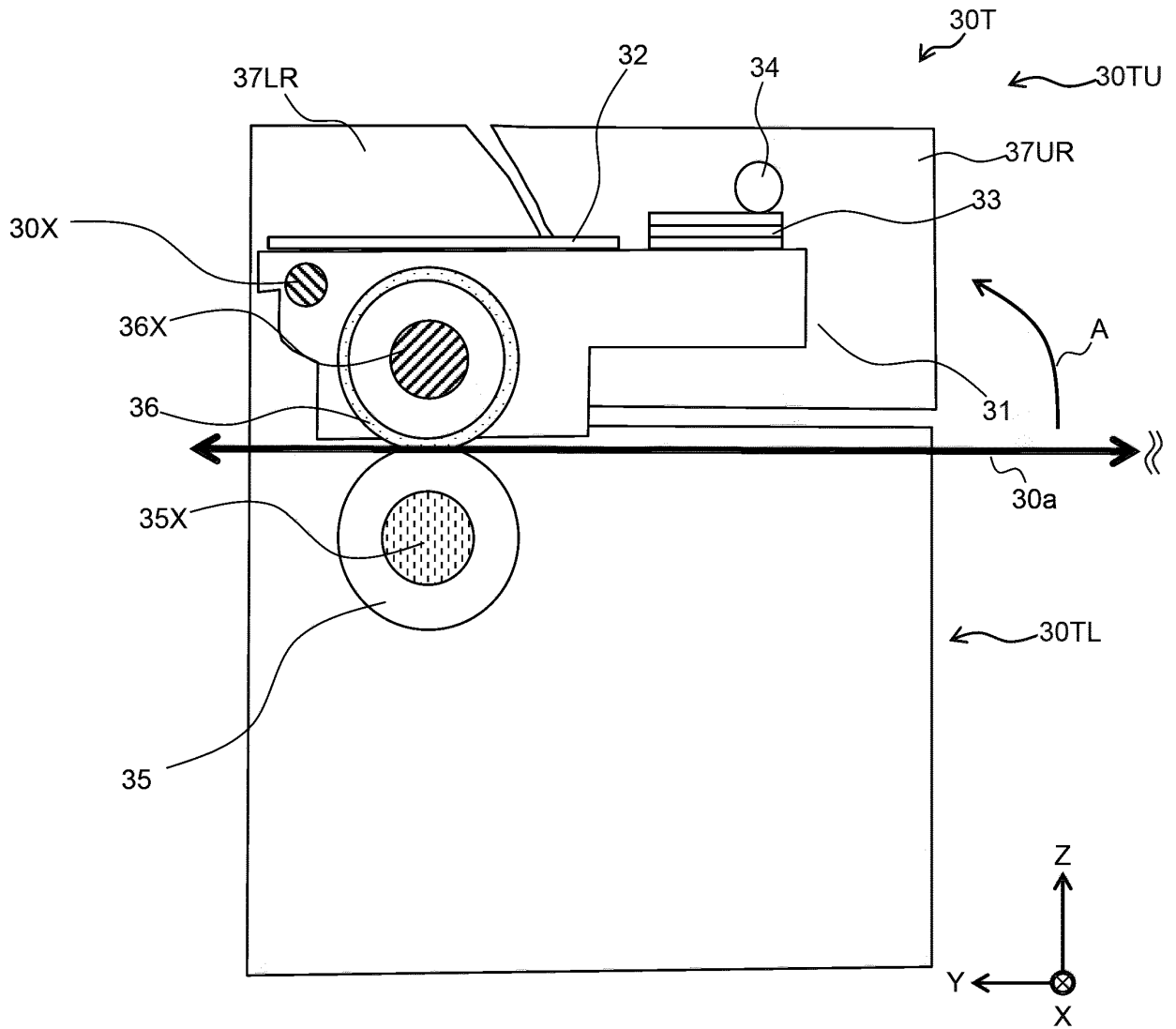

FIG. 10

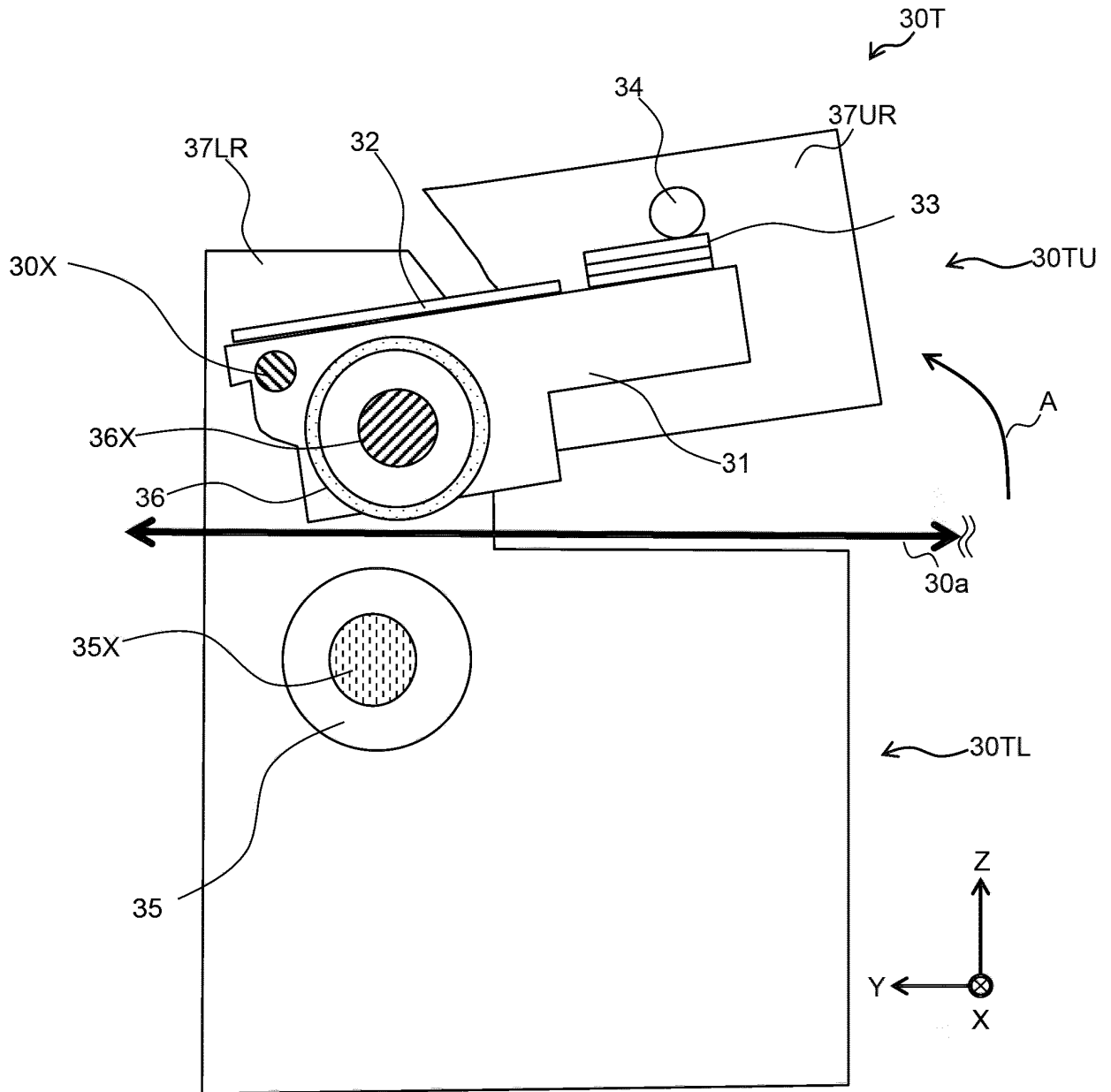

FIG. 11

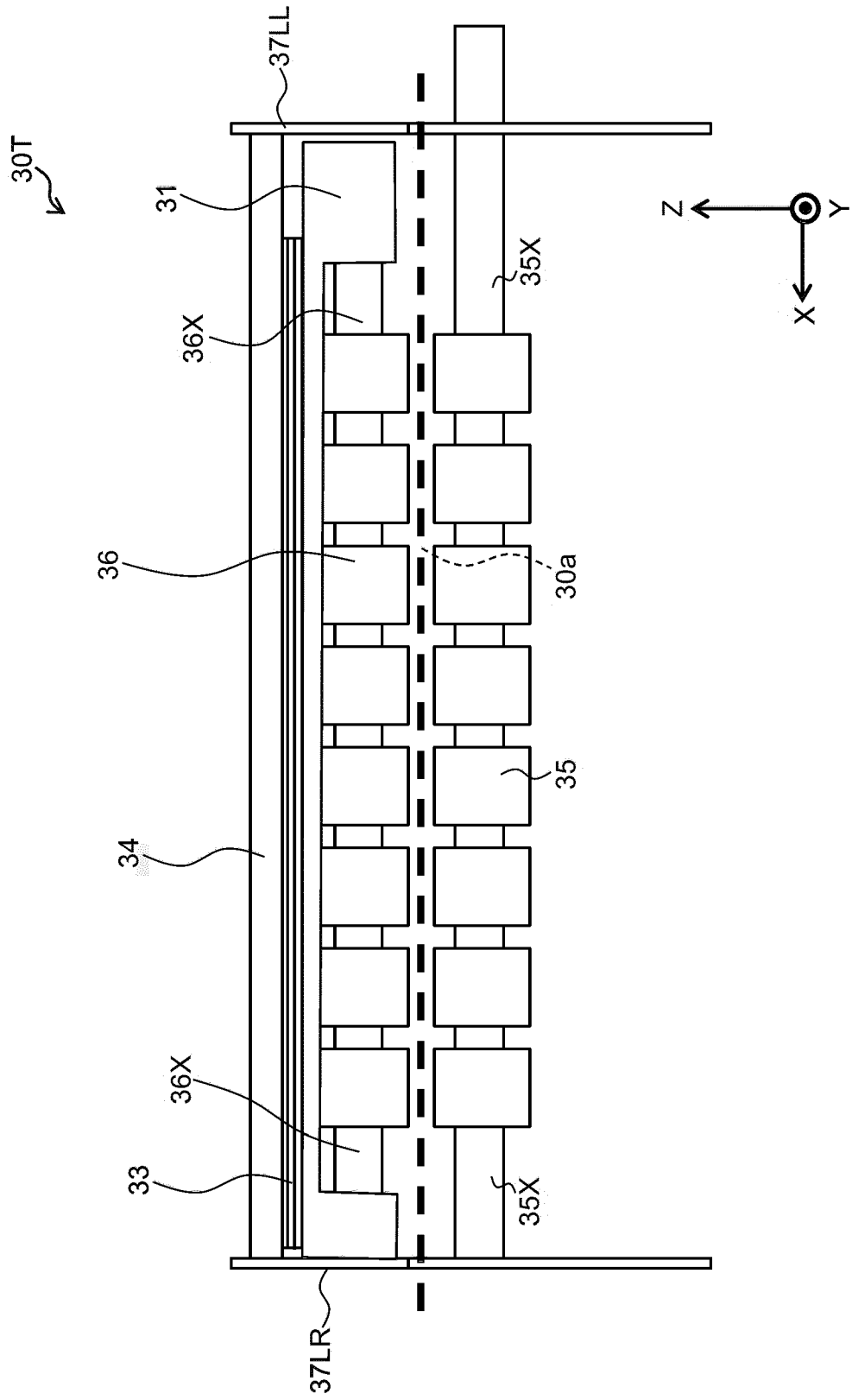

FIG. 12

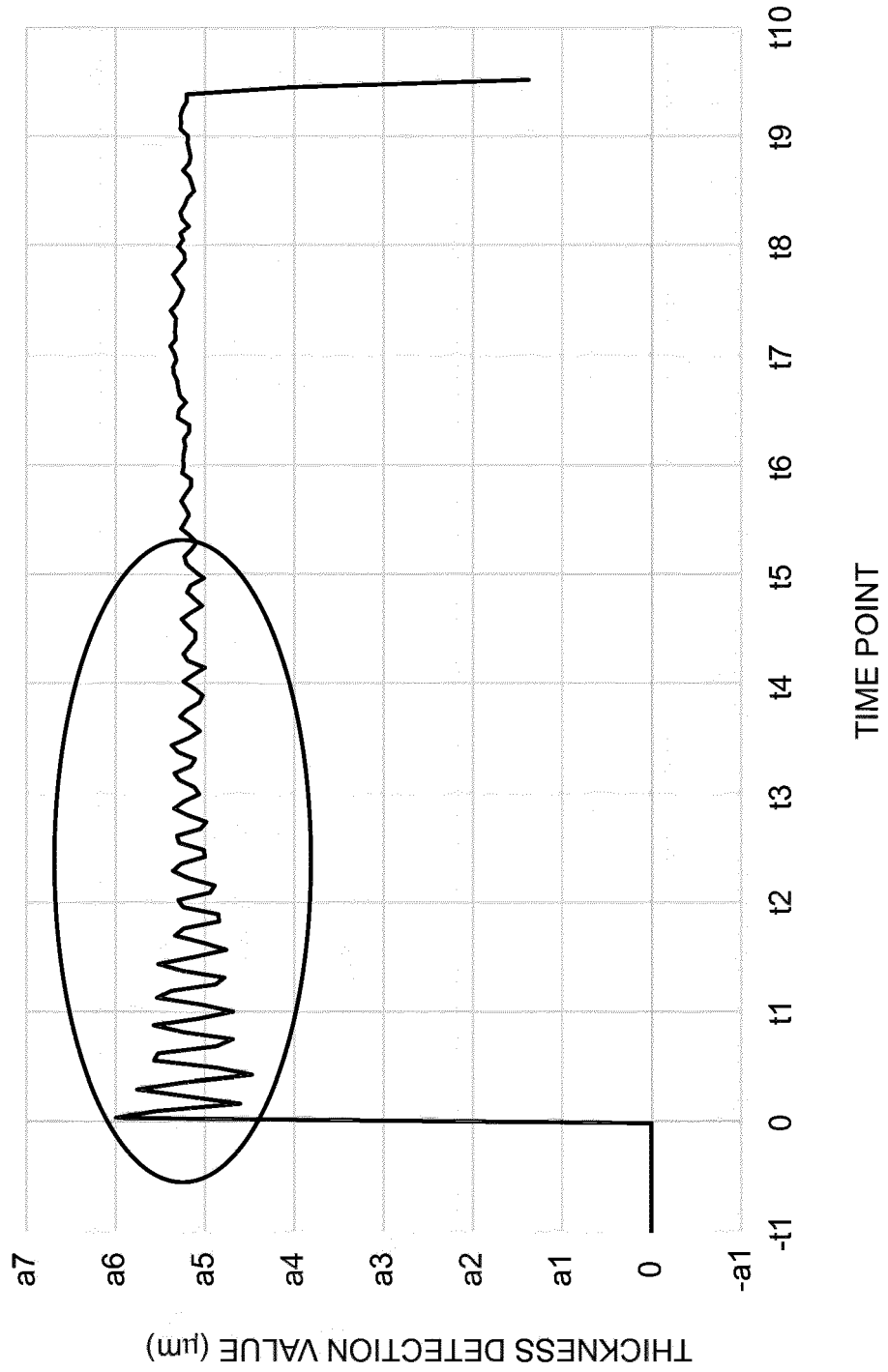

FIG. 13

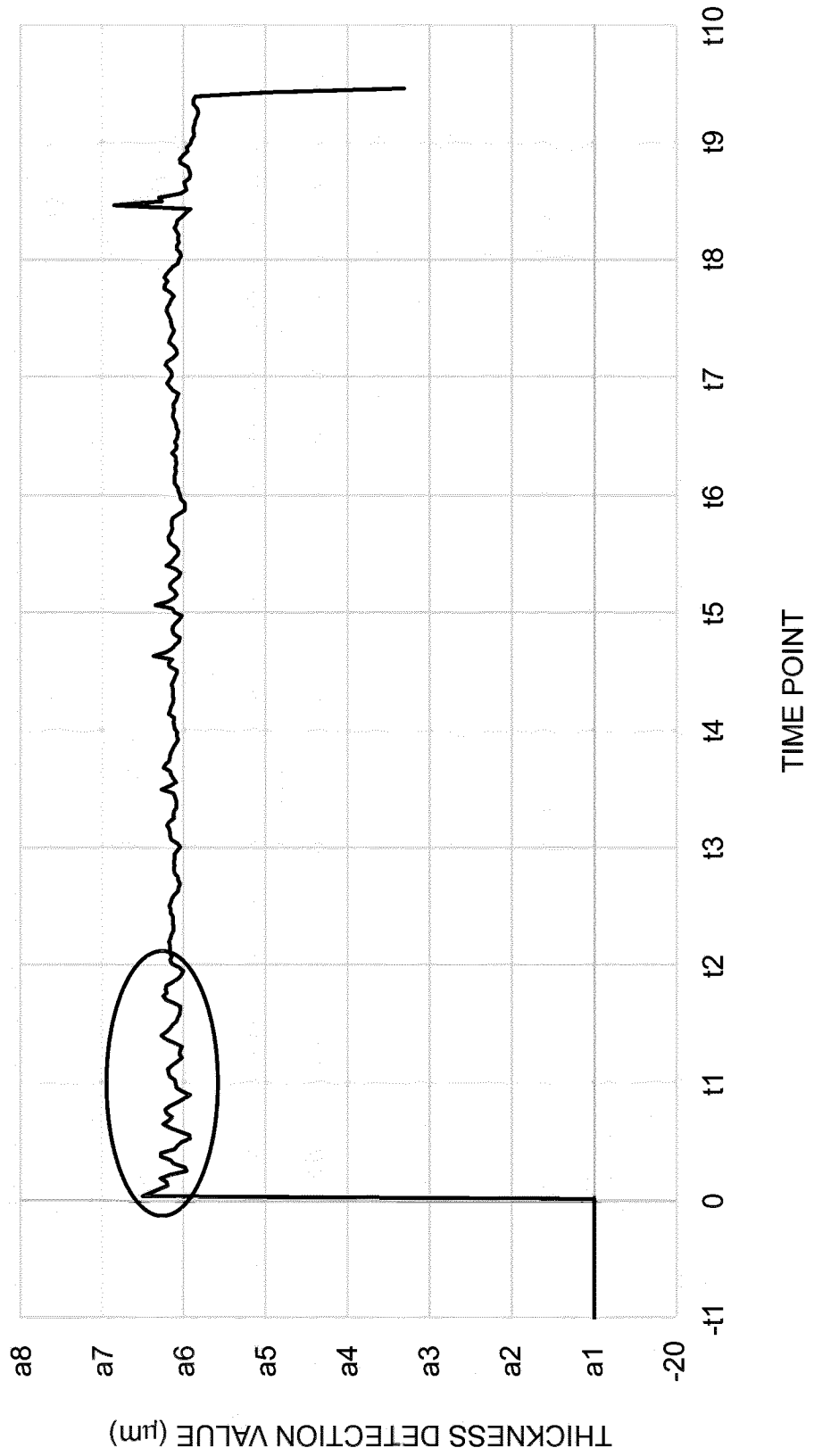

FIG. 14

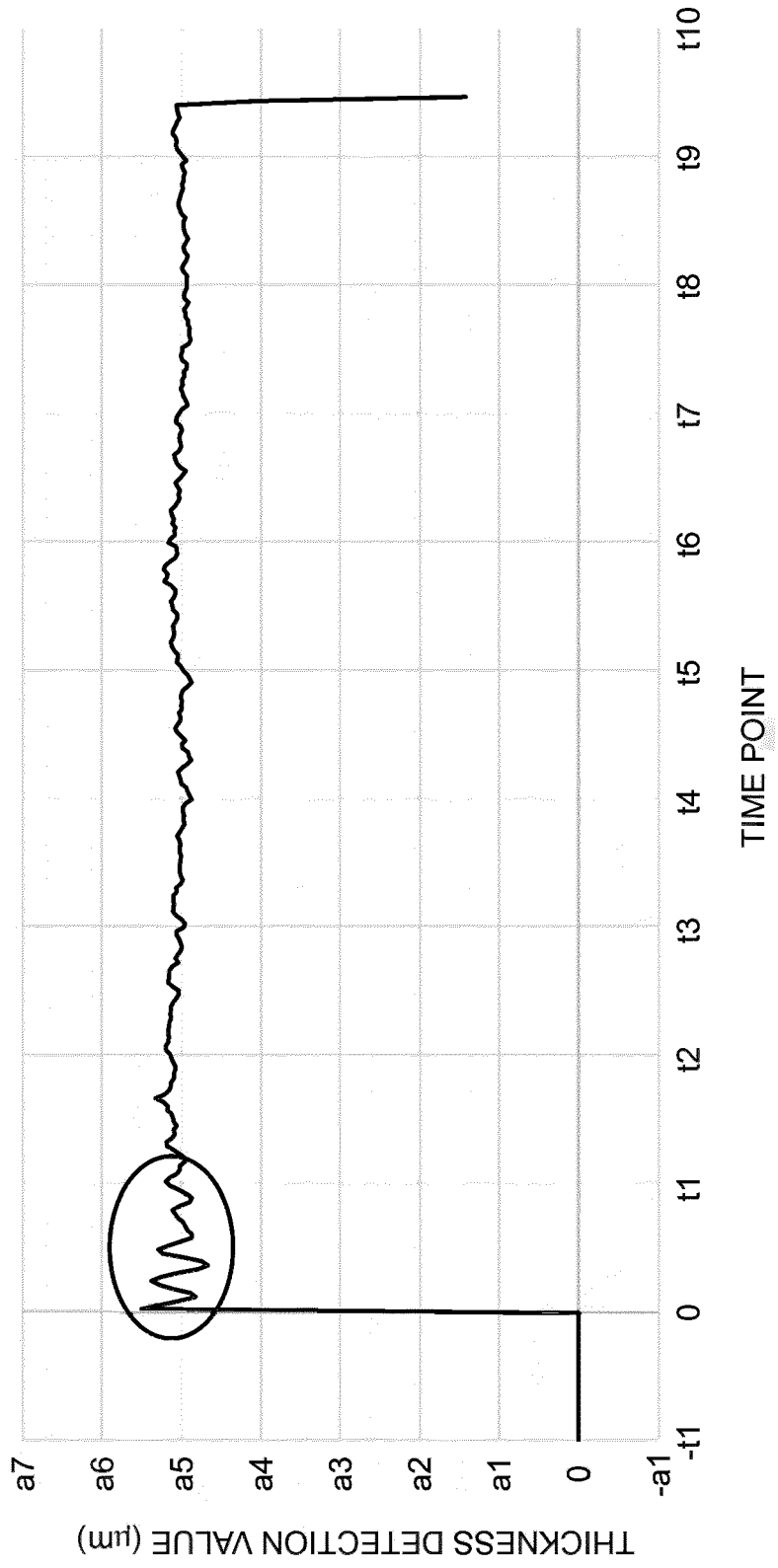
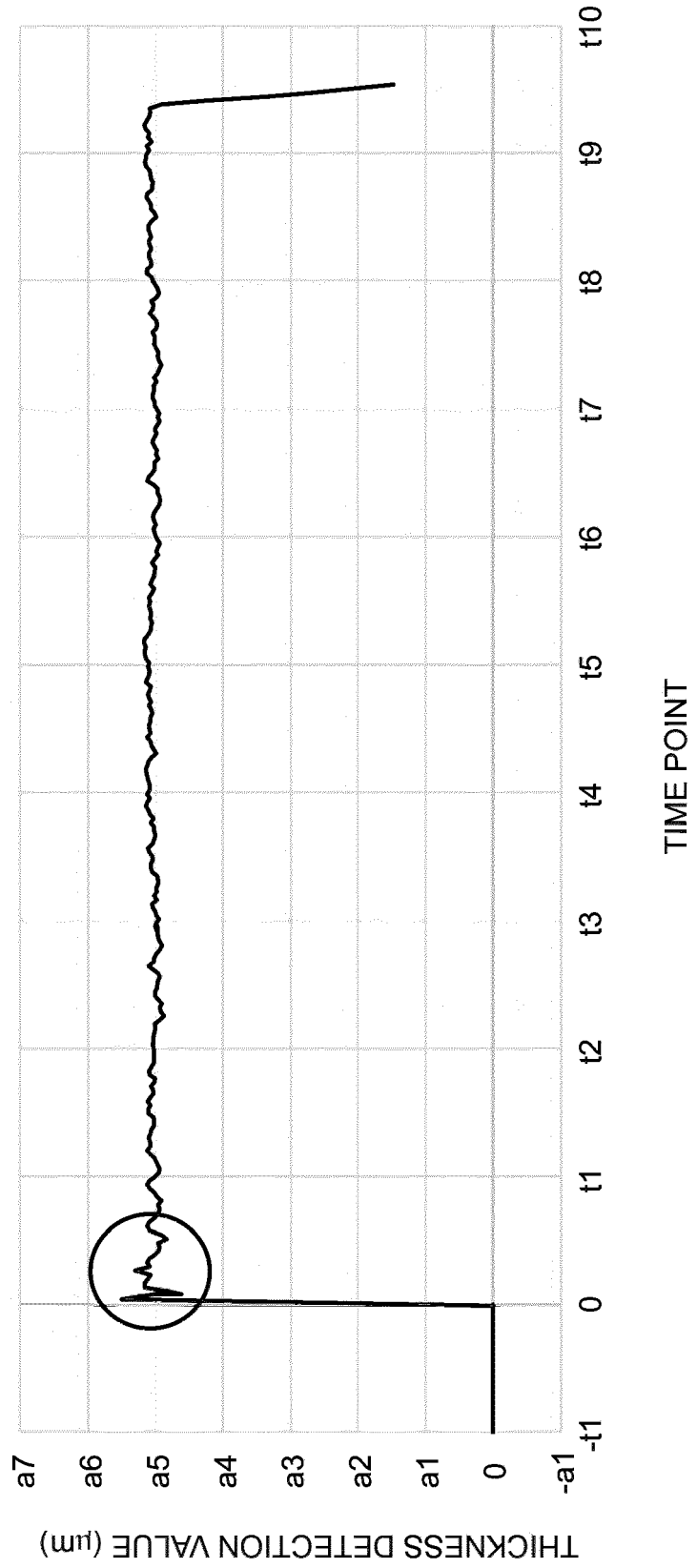

FIG. 15



**REFERENCES CITED IN THE DESCRIPTION**

*This list of references cited by the applicant is for the reader's convenience only. It does not form part of the European patent document. Even though great care has been taken in compiling the references, errors or omissions cannot be excluded and the EPO disclaims all liability in this regard.*

**Patent documents cited in the description**

- JP 2014102719 A [0003]
- US 2005056575 A1 [0003]
- US 4378109 A1 [0003]
- JP 2000357254 A [0003]
- JP 2020059559 A [0003]