



(12) **DEMANDE DE BREVET CANADIEN
CANADIAN PATENT APPLICATION**

(13) **A1**

(86) **Date de dépôt PCT/PCT Filing Date:** 2022/09/07
 (87) **Date publication PCT/PCT Publication Date:** 2023/03/16
 (85) **Entrée phase nationale/National Entry:** 2024/02/15
 (86) **N° demande PCT/PCT Application No.:** EP 2022/074818
 (87) **N° publication PCT/PCT Publication No.:** 2023/036802
 (30) **Priorité/Priority:** 2021/09/08 (EP21195601.6)

(51) **Cl.Int./Int.Cl. E21C 35/06** (2006.01)
 (71) **Demandeur/Applicant:**
 SANDVIK MINING AND CONSTRUCTION OY, FI
 (72) **Inventeurs/Inventors:**
 HANSKI, SAMI, FI;
 VALIVAARA, JOHANNES, FI;
 PESOLA, MIKKO, FI;
 VIINIKAINEN, MIKKO, FI;
 KORVA, TIMO, FI
 (74) **Agent:** GOWLING WLG (CANADA) LLP

(54) **Titre : FOURNITURE D'INFORMATIONS DE CONTROLE**
 (54) **Title: PROVIDING CONTROL INFORMATION**

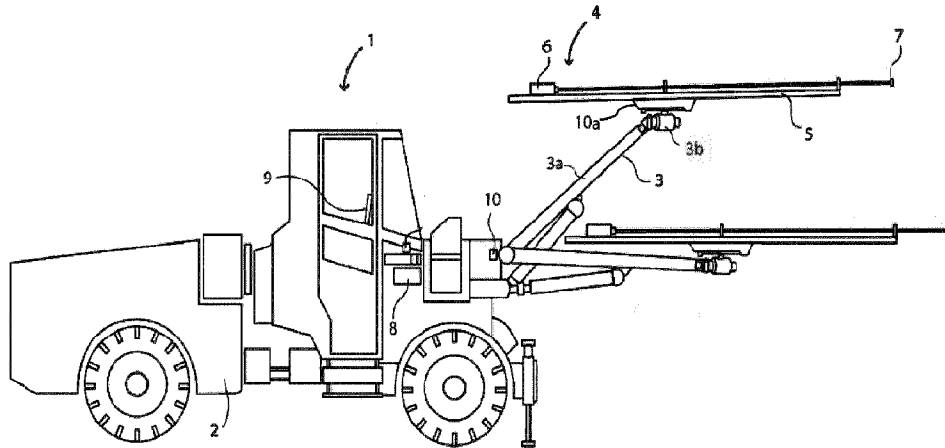

Figure 3

(57) **Abrégé/Abstract:**

An apparatus, method and computer program product for: determining a reference position of a feed beam, the feed beam being connected to a boom of a mobile mining machine; receiving measurement information provided by an inertial measurement unit associated with the feed beam, estimating, based on the measurement information, movement of the inertial measurement unit, and providing, based on the reference position of the feed beam and the estimated movement of the at inertial measurement unit, joint control information for controlling a position of the feed beam.

Date Submitted: 2024/02/15

CA App. No.: 3229097

Abstract:

An apparatus, method and computer program product for: determining a reference position of a feed beam, the feed beam being connected to a boom of a mobile mining machine; receiving measurement information provided by an inertial measurement unit associated with the feed beam, estimating, based on the measurement information, movement of the inertial measurement unit, and providing, based on the reference position of the feed beam and the estimated movement of the at inertial measurement unit, joint control information for controlling a position of the feed beam.

PROVIDING CONTROL INFORMATION

TECHNICAL FIELD

The present application relates generally to providing control information. More specifically, the present application relates to providing joint
5 control information.

BACKGROUND

Mobile mining machines work in a challenging environment such as in an underground mine.

Rock drilling is typically carried out by using drilling equipment
10 comprising a carrier provided with at least one boom with a rock drilling unit at a distal end of the at least one boom. The rock drilling unit comprises a feeding system configured to keep a drill bit in contact with rock during drilling. The feeding system comprises a feed beam configured to support and guide a rock
15 drilling device that is configured to move along the feed beam during a drilling procedure. As accurate control of the feed beam enables accurate rock drilling, controlling the position of the feed beam plays a role in efficient operation.

SUMMARY

Various aspects of examples of the invention are set out in the claims. The scope of protection sought for various embodiments of the invention is set out
20 by the independent claims. The examples and features, if any, described in this specification that do not fall under the scope of the independent claims are to be interpreted as examples useful for understanding various embodiments of the invention.

According to a first aspect of the invention, there is provided an
25 apparatus for controlling a mobile mining machine, the apparatus comprising means for performing: determining a reference position of a feed beam, the feed beam being connected to a boom of a mobile mining machine; receiving measurement information provided by an inertial measurement unit associated with the feed beam, estimating, based on the measurement information, movement
30 of the inertial measurement unit, and providing, based on the reference position of the feed beam and the estimated movement of the at inertial measurement unit, joint control information for controlling a position of the feed beam.

According to a second aspect of the invention, there is provided a method comprising: determining a reference position of a feed beam, the feed

beam being connected to a boom of a mobile mining machine; receiving measurement information provided by an inertial measurement unit associated with the feed beam, estimating, based on the measurement information, movement of the inertial measurement unit, and providing, based on the reference position of the feed beam and the estimated movement of the at inertial measurement unit, joint control information for controlling a position of the feed beam.

According to a third aspect of the invention, there is provided a computer program comprising instructions for causing an apparatus to perform at least the following: determining a reference position of a feed beam, the feed beam being connected to a boom of a mobile mining machine; receiving measurement information provided by an inertial measurement unit associated with the feed beam, estimating, based on the measurement information, movement of the inertial measurement unit, and providing, based on the reference position of the feed beam and the estimated movement of the at inertial measurement unit, joint control information for controlling a position of the feed beam.

According to a fourth aspect of the invention, there is provided an apparatus comprising at least one processor and at least one memory including computer program code, the at least one memory and the computer program code configured to with the at least one processor, cause the apparatus at least to: determine a reference position of a feed beam, the feed beam being connected to a boom of a mobile mining machine, receive measurement information provided by an inertial measurement unit associated with the feed beam, estimate, based on the measurement information, movement of the inertial measurement unit, and provide, based on the reference position of the feed beam and the estimated movement of the inertial measurement unit, joint control information for controlling a position of the feed beam.

According to a fifth aspect of the invention, there is provided a non-transitory computer readable medium comprising program instructions for causing an apparatus to perform at least the following: determining a reference position of a feed beam, the feed beam being connected to a boom of a mobile mining machine; receiving measurement information provided by an inertial measurement unit associated with the feed beam, estimating, based on the measurement information, movement of the inertial measurement unit, and providing, based on the reference position of the feed beam and the estimated movement of the at inertial measurement unit, joint control information for controlling a position of the feed beam.

According to a sixth aspect of the invention, there is provided a computer readable medium comprising program instructions for causing an apparatus to perform at least the following: determining a reference position of a feed beam, the feed beam being connected to a boom of a mobile mining machine; receiving measurement information provided by an inertial measurement unit associated with the feed beam, estimating, based on the measurement information, movement of the inertial measurement unit, and providing, based on the reference position of the feed beam and the estimated movement of the at inertial measurement unit, joint control information for controlling a position of the feed beam.

BRIEF DESCRIPTION OF THE DRAWINGS

Some example embodiments will now be described with reference to the accompanying drawings:

Figure 1 shows a block diagram of an example apparatus in which examples of the disclosed embodiments may be applied;

Figure 2 shows a block diagram of another example apparatus in which examples of the disclosed embodiments may be applied;

Figure 3 shows an example drilling rig;

Figure 4 illustrates an example system incorporating aspects of example embodiments; and

Figure 5 shows an example method incorporating aspects of examples of the invention.

DETAILED DESCRIPTION OF THE DRAWINGS

The following embodiments are exemplifying. Although the specification may refer to “an”, “one”, or “some” embodiment(s) in several locations of the text, this does not necessarily mean that each reference is made to the same embodiment(s), or that a particular feature only applies to a single embodiment. Single features of different embodiments may also be combined to provide other embodiments.

Example embodiments relate to controlling a position of a feed beam of a mobile mining machine. The mobile mining machine comprises at least one boom such as a drilling boom provided with a rock drilling unit at a distal end of the at least one boom. The rock drilling unit comprises a feeding system configured to keep a drill bit in contact with rock during drilling. The feeding system comprises a feed beam configured to support and guide a rock drilling device that is arranged

to move along the feed beam during a drilling procedure.

Currently, the position control of the feed beam is based on hydraulic or electronic control with joint sensors. The hydraulic control works only with specific boom kinematics and the electronic control needs sensors for at least all the rotation joints, thereby requiring rotational sensors and wiring for each joint axis. However, wiring and angle sensors are prone to damage, especially in an underground environment. In addition, the sensors need to be calibrated separately.

An example embodiment relates to an apparatus configured to determine a reference position of a feed beam, the feed beam being connected to a boom via at least one joint of a mobile mining machine, receive measurement information provided by an inertial measurement unit associated with the feed beam, estimate, based on the measurement information, movement of the inertial measurement unit, and provide, based on the reference position of the feed beam and the estimated movement of the inertial measurement unit, joint control information for controlling a position of the feed beam.

Figure 1 is a block diagram depicting an apparatus 100 operating in accordance with an example embodiment of the invention. The apparatus 100 may be, for example, an electronic device such as a module comprised by an automation or control system, a chip or a chipset. The apparatus 100 comprises one or more control circuitry, such as at least one processor 110 and at least one memory 160, including one or more algorithms such as computer program instructions 120 wherein the at least one memory 160 and the computer program instructions are configured, with the at least one processor 110 to cause the apparatus to carry out any of example functionalities described below.

In the example of Figure 1, the processor 110 is a control unit operatively connected to read from and write to the memory 160. The processor 110 may also be configured to receive control signals received via an input interface and/or the processor 110 may be configured to output control signals via an output interface. In an example embodiment the processor 110 may be configured to convert the received control signals into appropriate commands for controlling functionalities of the apparatus.

The at least one memory 160 stores computer program instructions 120 which when loaded into the processor 110 control the operation of the apparatus 100 as explained below. In other examples, the apparatus 100 may comprise more than one memory 160 or different kinds of storage devices.

Computer program instructions 120 for enabling implementations of example embodiments of the invention or a part of such computer program instructions may be loaded onto the apparatus 100 by the manufacturer of the apparatus 100, by a user of the apparatus 100, or by the apparatus 100 itself based on a download program, or the instructions can be pushed to the apparatus 100 by an external device. The computer program instructions may arrive at the apparatus 100 via an electromagnetic carrier signal or be copied from a physical entity such as a computer program product, a memory device or a record medium such as a USB stick, a Compact Disc (CD), a Compact Disc Read-Only Memory (CD-ROM), a Digital Versatile Disk (DVD) or a Blu-ray disk.

Figure 2 is a block diagram depicting an apparatus 200 in accordance with an example embodiment of the invention. The apparatus 200 may be an electronic device such as a module comprised by an automation system or a control system, a Personal Computer (PC), a laptop, a desktop, a wireless terminal, a communication terminal, a computing device or the like. In the examples below it is assumed that the apparatus 200 is a computing device.

In the example embodiment of Figure 2, the apparatus 200 is illustrated as comprising the apparatus 100, a display 210 and a user interface 220 for interacting with the computing device 200. The display 210 may also be configured to act as a user interface. For example, the display may be a touch screen display. In an example embodiment, the display 210 and/or the user interface 220 may be external to the apparatus 200, but in communication with it.

Additionally or alternatively, the user interface may also comprise a manually operable control such as a button, a key, a touch pad, a joystick, a stylus, a pen, a roller, a rocker, a keypad, a keyboard or any suitable input mechanism for inputting and/or accessing information.

The apparatus 200 of the example of Fig. 2 may also be configured to establish radio communication with another device using, for example, a cellular network, a Bluetooth or WiFi connection or the like. Alternatively or in addition, the apparatus 200 may be configured to communicate with another device using a wired connection.

According to an example embodiment, the apparatus 200 comprises a module operatively connected to a mobile mining machine. For example, the apparatus 200 may be implemented in a control system of a mobile mining machine or the apparatus 200 may be configured to communicate with a control system of a mobile mining machine via a wired or wireless connection.

According to an example embodiment, the mobile mining machine comprises a drilling rig.

According to an example embodiment, the mobile mining machine comprises a carrier and at least one boom.

5 As explained above, the mobile mining machine comprises at least one boom provided with a rock drilling unit at a distal end of the at least one boom. The rock drilling unit comprises a feeding system configured to keep a drill bit in contact with rock during drilling. The feeding system comprises a feed beam configured to move with respect to a feed cradle connected to the at least one boom
10 via one or more rotatable joints. The feed beam is configured to support and guide a rock drilling device that is arranged to move along the feed beam during a drilling procedure. The feed beam may comprise a feed rail.

Accurate rock drilling is required in order to avoid an incorrect tunnel profile. Therefore, the apparatus 200 is configured to monitor and control the
15 position of the feed beam. Monitoring and controlling the position of the feed beam may be performed based on a reference position of the feed beam.

According to an example embodiment, a position of the feed beam comprises an orientation of the feed beam with respect to a reference position of the feed beam.

20 A reference position of a feed beam may comprise a desired position of the feed beam. A reference position may comprise a predetermined reference position or the apparatus 200 may be configured to determine the reference position based on, for example, measurement data, sensor data, a simulation, a machine learning algorithm, operator input, one or more environmental factors, a
25 procedure for setting a reference position such as a navigation procedure and/or the like.

According to an example embodiment, the apparatus 200 is configured to determine the reference position based on information provided by a magnetometer and/or a gyrocompass. For example, the apparatus 200 may be
30 configured to receive information provided by a magnetometer and/or a gyrocompass and determine the reference position based on the received information.

According to an example embodiment, the apparatus 200 is configured to determine a reference position based on a navigation procedure. The navigation
35 procedure may comprise, for example, aligning the boom to a desired position. For example, the apparatus 200 may be configured to determine the reference position

based on a position of an aligned boom in response to receiving an indication that the position of the aligned boom is accepted by the operator.

As another example, the apparatus 200 may be configured to determine the reference position based on a position of an aligned boom in response to receiving an indication that the position of the aligned boom corresponds to a predetermined alignment. A predetermined alignment may be indicated with a laser beam, for example.

According to an example embodiment, the apparatus 200 is configured to determine a reference position of a feed beam, the feed beam being connected to a boom of a mobile mining machine.

A reference position of the feed beam may comprise location information and/or orientation information. Location information may comprise an absolute location such as a location in coordinates of a coordinate system or a relative location such as a location with respect to a particular reference point. Orientation information may comprise an angular position with respect to a particular reference point.

According to an example embodiment, the reference position comprises an angle of the feed beam with respect to the mobile mining machine. An angle of the feed beam with respect to the mobile mining machine may comprise an angle of the feed beam with respect to a predetermined reference point associated with the mobile mining machine.

According to another example embodiment, the reference position comprises an angle of the feed beam with respect to gravity. An angle of the feed beam with respect to gravity may comprise an angle of the feed beam with respect to a direction of gravity at a geographic location.

A direction of gravity may be considered as substantially stable and predictable on earth at least within a limited geographic area and substantially the same during a period of time.

Without limiting the scope of the claims, an advantage of the reference position comprising an angle of the feed beam with respect to gravity is that gravity enables an accurate and repeatable positioning independent of the position of the mobile mining machine.

According to an example embodiment, the reference position comprises a drilling angle. A drilling angle may comprise an orientation of the feed beam with respect to the mobile mining machine during drilling or an orientation of the feed beam with respect to gravity.

According to an example embodiment, the drilling angle comprises at least one of the following: a vertical angle or a horizontal angle.

A vertical angle comprises an angle between the feed beam and a horizontal plane and a horizontal angle comprises an angle between the feed beam
5 and a vertical plane.

According to an example embodiment, the feed beam is mechanically connected to the boom. For example, the feed beam may be connected to a boom directly, through different kinds of joints and/or a feed cradle.

According to an example embodiment, the apparatus 200 is configured to
10 receive measurement information provided by an inertial measurement unit associated with the feed beam. Measurement information may comprise, for example, measurement data and/or metadata relating to the measurement data, and the apparatus 200 may be configured to receive the measurement information provided by the inertial measurement unit via a wireless or wired connection.

Without limiting the scope of the claims, an advantage of associating the
15 inertial measurement unit with the feed beam is that, based on the measurement information provided by the inertial measurement unit, position and/or movement of the feed beam may be determined.

An inertial measurement unit associated with a feed beam may
20 comprise an inertial measurement unit installed in the feeding system. According to an example embodiment, the inertial measurement unit is installed to a feed rail. According to another example embodiment, the inertial measurement unit is installed to a feed cradle.

Without limiting the scope of the claims, an advantage of installing the
25 inertial measurement unit to the feed rail or the feed cradle is that the structure of the feeding system may protect the inertial measurement unit from falling rocks, for example, thereby making the inertial measurement unit less prone to damage.

An inertial measurement unit is configured to detect linear acceleration and angular velocity using a plurality of inertial sensors such as one or more
30 accelerometers and one or more gyroscopes. An inertial measurement unit may further comprise a magnetometer for detecting a compass heading.

According to an example embodiment, the inertial measurement unit
comprises at least one accelerometer and at least one gyroscope. According to an
example embodiment, the inertial measurement unit further comprises at least one
35 magnetometer.

According to an example embodiment, the apparatus 200 is configured

to determine a position of the inertial measurement unit based on the measurement information provided by the inertial measurement unit. A position of the inertial measurement unit may comprise, for example, a six degrees of freedom (6 DOF) position of the inertial measurement unit. The apparatus 200 is further configured to determine the position of the feed beam based on the position of the inertial measurement unit associated with the feed beam.

The apparatus 200 may further be configured to determine or estimate movement of the inertial measurement unit based on a change of position of the inertial measurement unit.

According to an example embodiment, the apparatus 200 is configured to estimate, based on the measurement information, movement of the at least one inertial measurement unit.

The apparatus 200 may be configured to estimate movement of the at least one inertial measurement unit by using one or more sensor fusion algorithms.

A sensor fusion algorithm may be configured to combine data from a plurality of sensors such as one or more accelerometers, gyroscopes and/or magnetometers in order to estimate a position of an object. As the inertial measurement unit is associated with the feed beam, a sensor fusion algorithm may be used for estimating the orientation and movement of the feed beam.

Without limiting the scope of the claims, an advantage estimating the orientation and movement of a feed beam using an inertial measurement unit is that rotational joint sensors requiring a sensors and wiring for each joint axis may be replaced with a single inertial measurement unit. Further, as rotational joint sensors and wiring are prone to damage in an underground mining environment, placing the inertial measurement unit appropriately enables reducing the number of interruptions caused by damaged sensors and/or wiring. Further, as calibration of a plurality of separate sensors is not necessary, using an inertial measurement unit enables more efficient operation.

According to an example embodiment, the apparatus 200 is configured to determine, based on the reference position of the feed beam and the estimated movement of the inertial measurement unit, joint control information for controlling a position of the feed beam.

Determining the joint control information may comprise, for example, determining the position of the feed beam based on the measurement information provided by the inertial measurement unit, comparing the position of the feed beam with the reference position of the feed beam, and determining a control

signal for maintaining the position of the feed beam with respect to the mobile mining machine or with respect to gravity.

According to an example embodiment, the apparatus 200 is configured to provide, based on the reference position of the feed beam and the estimated
5 movement of the inertial measurement unit, joint control information for controlling a position of the feed beam.

Without limiting the scope of the claims, an advantage of providing joint control information for controlling a position of the feed beam based on the reference position of the feed beam and the estimated movement of the inertial
10 measurement unit is that the position of the feed beam may be substantially maintained while operating the mobile mining machine. For example, the position of the feed beam may be maintained while controlling the at least one boom.

Joint control information may comprise at least one control signal for controlling at least one valve configured to control an orientation of the feed beam
15 and/or a position offset of the feed beam with respect to a reference point of the feed beam. The at least one valve may comprise, for example, a valve configured to control an orientation of the feed beam.

According to an example embodiment, the joint control information comprises joint control signals for controlling an orientation of the feed beam
20 and/or controlling a position offset of the feed beam.

The apparatus 200 may be configured to provide the joint control information to a dedicated controller configured to control the at least one valve or the apparatus 200 may be configured to control the at least one valve directly.

According to an example embodiment, the apparatus 200 is configured
25 to control at least one valve based on the joint control information. Controlling the at least one valve may comprise controlling the at least one valve directly or through a dedicated controller.

The apparatus 200 may be configured to control the at least one valve continuously or when at least one predetermined criterion is fulfilled. The at least
30 one predetermined criterion may relate to, for example, a particular control mode, a particular state of the mobile mining machine, and/or the like. For example, the apparatus 200 may be configured to control the at least one valve, when the mobile mining machine is stationary, but the boom is moving, or when the mobile mining machine is in a control mode aiming is to keep the feed beam in a desired
35 orientation when the boom is moving.

According to an example embodiment, the apparatus 200 is configured

to control the at least one valve during boom movement.

Without limiting the scope of the claims, an advantage of controlling the at least one valve during boom movement is that the position of the feed beam with respect to the mobile mining machine may be maintained when an operator moves
5 the boom. In this way, drilling accuracy may be maintained even when the boom is moved.

In addition to the measurement information received from the inertial measurement unit, the apparatus 200 may be configured to utilize information from other sources for providing joint control information for controlling a
10 position of the feed beam.

The information from other sources may comprise, for example, contextual information relating to the mobile mining machine. Contextual information may comprise, for example, information on the environment or information on a structure of the mobile mining machine. Information on
15 environment may comprise, for example, a model of the working environment of the mobile mining device such as a mine model. Information on a structure of the mobile mining machine may comprise, for example, information on a current position of one or more other booms of a multi-boom mobile mining machine.

According to an example embodiment, the apparatus 200 is configured
20 to adjust the joint control information based on contextual information relating to the mobile mining machine.

Without limiting the scope of the claims, an advantage of utilizing additional information for providing joint control information is that, for example, collision with a tunnel floor or ceiling, or with other booms may be avoided.

According to an example embodiment, the apparatus 200 is configured
25 to monitor the position and/or movement of the feed beam. Monitoring the position and/or movement of the feed beam may comprise, for example, providing information relating to the position and/or movement of the feed beam to a display. For example, the apparatus 200 may be configured to provide information
30 on a display on the reference position of the feed beam, an estimated position of the feed beam, a difference between the reference position and the estimated position of the feed beam, or the like. Further, the apparatus 200 may be configured to provide information of the joint control information on a display.

According to an example embodiment, the apparatus 200 is configured
35 to provide information on an estimated orientation and/or estimated position offset of the feed beam on a display.

Monitoring may further comprise indicating when the position of the feed beam fulfills at least one criterion. The apparatus 200 may be configured to, for example, provide a notification for the operator in response to movement of the feed beam reaching a predetermined threshold value. For example, assuming the operator has set a threshold value of 70 cm between holes to be drilled, the apparatus 200 may be configured to notify the operator when the feed beam has moved 70 cm, thereby assisting the operator to perform hole drilling more efficiently.

According to an example embodiment, the apparatus 200 is configured to determine that movement of the feed beam has reached a threshold value. A threshold value may comprise an orientation of the feed beam or a distance moved by the feed beam.

According to an example embodiment, the apparatus 200 is configured to provide a notification on a display in response to determining that the movement of the feed beam has reached a threshold value.

According to an example embodiment, the apparatus 200 comprises means for performing features of the apparatus 200, wherein the means for performing comprises at least one processor 110, at least one memory 160 including computer code 120 configured to, with the at least one processor 110, cause the performance of the apparatus 200.

According to an example embodiment, the apparatus 200 comprises means for determining a reference position of a feed beam, the feed beam being connected to a boom via at least one joint of a mobile mining machine, means for receiving measurement information provided by an inertial measurement unit associated with the feed beam, means for estimating, based on the measurement information, movement of the inertial measurement unit, and means for providing, based on the reference position of the feed beam and the estimated movement of the inertial measurement unit, joint control information for controlling a position of the feed beam.

According to an example embodiment, the apparatus 200 may further comprise means for controlling at least one valve based on the joint control information, means for adjusting the joint control information based contextual information relating to the mobile mining machine and/or means for controlling the at least one valve during boom movement. The apparatus 200 may further comprise means for providing information on an estimated orientation and/or estimated position offset of the feed beam on a display. The apparatus 200 may

further comprise means for determining that movement of the feed beam has reached a threshold value, and/or means for providing a notification on a display in response to determining that movement of the feed beam has reached a threshold value.

5 Figure 3 illustrates an example drilling rig. In the example of Figure 3 the drilling rig comprises a rock drilling rig 1 comprising a carrier 2, one or more drilling booms 3 and drilling units 4 associated with the drilling booms 3. The boom may comprise two or more parts, objects, or portions 3a, 3b connected by a joint. In the example of Figure 3, the boom is further connected to a drilling unit 4 by a joint. The drilling unit 4 comprises a feed beam 5 on which a rock drilling device 6
10 can be moved by means of a feed device. Further, the drilling unit 4 comprises a tool 7 with which impact pulses given by a percussion device of the rock drilling device 6 are transmitted to the rock to be drilled. As mentioned above, an inertial measurement unit may be associated with the feed beam 5 by installing the inertial
15 measurement unit to, for example, a feed rail or feed cradle 10a.

In the example of Figure 3, the rock drilling rig 1 further comprises at least one control unit 8 arranged to control actuators of the rock drilling rig 1, for example. The control unit 8 may comprise, for example, the apparatus 200 comprising one or more processors executing computer program code stored in a
20 memory, and it may comprise or be connected to a user interface with a display device 9 as well as operator input interface for receiving operator commands and information to the control unit 8. In some embodiments, the control unit 8 is configured to control at least boom automation control related operations, and there may be one or more other control units in the rig for controlling other
25 operations.

Further, one or more sensors 10 may be arranged for determining current position and direction of portions of the boom 3 and further the tool 7. Such sensors 10 may locate in connection with the boom 3, or alternatively the sensing may be executed remotely from the carrier or even elsewhere. The sensing data
30 may be provided to the control unit 8 (or another control unit for positioning), which may execute appropriate computations.

Figure 4 illustrates an example system 400 incorporating aspects of the previously disclosed embodiments. In the example of Figure 4, the apparatus 200 receives measurement information from an inertial measurement unit (IMU) 410.

35 As mentioned above an inertial measurement unit is configured to detect linear acceleration and angular velocity using a plurality of inertial sensors

such as one or more accelerometers and one or more gyroscopes. An inertial measurement unit may further comprise a magnetometer for detecting a compass heading. In the example of Figure 4, the inertial measurement unit 410 comprises at least one three-dimensional (3D) accelerometer and at least one 3D gyroscope.

5 The apparatus 200 is configured to determine a reference position of a feed beam, the feed beam being connected to a boom via at least one joint of a mobile mining machine, receive measurement information provided by an inertial measurement unit associated with the feed beam, estimate, based on the measurement information, movement of the inertial measurement unit, and
10 provide, based on the reference position of the feed beam and the estimated movement of the inertial measurement unit, joint control information for controlling a position of the feed beam.

 In the example of Figure 4, the position of the feed beam is controlled using valves 420 and 430. Valves 420 and 430 may comprise, for example, a valve
15 configured to control an orientation of the feed beam.

 Figure 5 illustrates an example method 500 incorporating aspects of the previously disclosed embodiments. More specifically, the example method 500 illustrates providing control information. The method 500 may be performed by the apparatus 200.

20 The method starts with determining 510 a reference position of a feed beam, the feed beam being connected to a boom of a mobile mining machine.

 A reference position of the feed beam may comprise location information and/or orientation information. Location information may comprise an absolute location such as a location in coordinates of a coordinate system or a
25 relative location such as a location with respect to a particular reference point. Orientation information may comprise an angular position with respect to a particular reference point.

 In the example of Figure 5, the reference position comprises a drilling angle with respect to mobile mining machine. A drilling angle may comprise a
30 vertical angle or a horizontal angle.

 The method continues with receiving 520 measurement information provided by an inertial measurement unit associated with the feed beam. An inertial measurement unit associated with a feed beam may comprise an inertial measurement unit installed in the feeding system such as an inertial measurement
35 unit is installed to a feed rail or a feed cradle.

 The method further continues with estimating 530, based on the

measurement information, movement of the inertial measurement unit. Movement of the inertial measurement unit may be estimated using, for example, one or more sensor fusion algorithms.

5 The method further continues with providing 540, based on the reference position of the feed beam and the estimated movement of the inertial measurement unit, joint control information for controlling a position of the feed beam.

10 Joint control information may comprise at least one control signal for controlling at least one valve configured to control an orientation of the feed beam and/or a position offset of the feed beam with respect to a reference point of the feed beam. The at least one valve may comprise, for example, a valve configured to control an orientation of the feed beam.

15 Without limiting the scope of the claims, an advantage of providing joint control information for controlling a position of a feed beam based on measurement information received from an inertial measurement unit associated with the feed beam is that a plurality of rotational joint sensors may be replaced with a single inertial measurement unit. Another advantage is that the inertial measurement unit may be installed such that the structure of the mobile mining machine may protect the inertial measurement unit from external impacts.

20 Without in any way limiting the scope, interpretation, or application of the claims appearing below, a technical effect of one or more of the example embodiments disclosed herein is that disruptions in controlling a position of the feed beam may be reduced as the inertial measurement unit is protected by the structure of the mobile mining machine. A further technical effect may be that the number of components needed for controlling position of the feed beam may be reduced.

25 As used in this application, the term "circuitry" may refer to one or more or all of the following: (a) hardware-only circuit implementations (such as implementations in only analog and/or digital circuitry) and (b) combinations of hardware circuits and software, such as (as applicable): (i) a combination of analog and/or digital hardware circuit(s) with software/firmware and (ii) any portions of hardware processor(s) with software (including digital signal processor(s)), software, and memory(ies) that work together to cause an apparatus, such as a mobile phone or server, to perform various functions) and (c) hardware circuit(s) and or processor(s), such as a microprocessor(s) or a portion of a microprocessor(s), that requires software (e.g., firmware) for operation, but the

software may not be present when it is not needed for operation.

This definition of circuitry applies to all uses of this term in this application, including in any claims. As a further example, as used in this application, the term circuitry also covers an implementation of merely a hardware
5 circuit or processor (or multiple processors) or portion of a hardware circuit or processor and its (or their) accompanying software and/or firmware. The term circuitry also covers, for example and if applicable to the particular claim element, a baseband integrated circuit or processor integrated circuit for a mobile device or a similar integrated circuit in server, a cellular network device, or other computing
10 or network device.

Embodiments of the present invention may be implemented in software, hardware, application logic or a combination of software, hardware and application logic. The software, application logic and/or hardware may reside on the apparatus, a separate device or a plurality of devices. If desired, part of the
15 software, application logic and/or hardware may reside on the apparatus, part of the software, application logic and/or hardware may reside on a separate device, and part of the software, application logic and/or hardware may reside on a plurality of devices. In an example embodiment, the application logic, software or an instruction set is maintained on any one of various conventional computer-
20 readable media. In the context of this document, a 'computer-readable medium' may be any media or means that can contain, store, communicate, propagate or transport the instructions for use by or in connection with an instruction execution system, apparatus, or device, such as a computer, with one example of a computer described and depicted in FIGURE 2. A computer-readable medium may comprise
25 a computer-readable storage medium that may be any media or means that can contain or store the instructions for use by or in connection with an instruction execution system, apparatus, or device, such as a computer.

If desired, the different functions discussed herein may be performed in a different order and/or concurrently with each other. Furthermore, if desired, one
30 or more of the above-described functions may be optional or may be combined.

Although various aspects of the invention are set out in the independent claims, other aspects of the invention comprise other combinations of features from the described embodiments and/or the dependent claims with the features of the independent claims, and not solely the combinations explicitly set out in the
35 claims.

It will be obvious to a person skilled in the art that, as the technology

advances, the inventive concept can be implemented in various ways. The invention and its embodiments are not limited to the examples described above but may vary within the scope of the claims.

CLAIMS

1. An apparatus for controlling a mobile mining machine comprising a carrier and at least one boom, the apparatus comprising at least one processor and at least one memory including computer program code, the at least one memory
5 and the computer program code configured to with the at least one processor, cause the apparatus at least to:

determine a reference position of a feed beam connected to a boom of the mobile mining machine, the reference position of the feed beam comprising a desired position of the feed beam;

10 receive measurement information provided by an inertial measurement unit associated with the feed beam;

estimate, based on the measurement information, movement of the inertial measurement unit associated with the feed beam; and

15 provide, based on the reference position of the feed beam and the estimated movement of the inertial measurement unit, joint control information for controlling a position of the feed beam.

2. The apparatus according to claim 1, wherein the reference position comprises an angle of the feed beam with respect to the mobile mining machine or
20 with respect to gravity.

3. The apparatus according to claim 1 or 2, wherein the reference position comprises a drilling angle.

25 4. The apparatus according to claim 3, wherein the drilling angle comprises at least one of the following: a vertical angle or a horizontal angle.

5. The apparatus according to any preceding claim, wherein the at least one memory and the computer program code are further configured to with the at least one processor, cause the apparatus to control at least one valve based on the
30 joint control information.

6. The apparatus according to claim 5, wherein the at least one memory and the computer program code are configured to with the at least one processor,
35 cause the apparatus to control the at least one valve during boom movement.

7. The apparatus according to any preceding claim, wherein the joint control information comprises joint control signals for at least one of the following: controlling an orientation of the feed beam or controlling a position offset of the feed beam.

5

8. The apparatus according to any preceding claim, wherein the at least one memory and the computer program code are configured to with the at least one processor, cause the apparatus to provide information on an estimated orientation and/or estimated position offset of the feed beam on a display.

10

9. The apparatus according to any preceding claim, wherein the inertial measurement unit is installed to a feed rail or feed cradle.

10. The apparatus according to any preceding claim, wherein the at least one memory and the computer program code are configured to with the at least one processor, cause the apparatus to determine that movement of the feed beam has reached a threshold value.

11. The apparatus according to any preceding claim, wherein the at least one memory and the computer program code are configured to with the at least one processor, cause the apparatus to adjust the joint control information based contextual information relating to the mobile mining machine.

12. The apparatus according to any preceding claim, wherein the inertial measurement unit comprises at least one accelerometer and at least one gyroscope.

13. A drilling rig comprising an apparatus according to any preceding claim.

30

14. A method for controlling a feed beam of a mobile mining machine, the mobile mining machine comprising a carrier and at least one boom, the method comprising:

determining a reference position of a feed beam connected to a boom of the mobile mining machine, the reference position of the feed beam comprising a desired position of the feed beam;

35

receiving measurement information provided by an inertial measurement unit associated with the feed beam;

estimating, based on the measurement information, movement of the inertial measurement unit associated with the feed beam; and

5 providing, based on the reference position of the feed beam and the estimated movement of the at inertial measurement unit, joint control information for controlling a position of the feed beam.

15 15. A computer program comprising instructions for causing an apparatus to perform at least the following:

determining a reference position of a feed beam connected to a boom of a mobile mining machine, the reference position of the feed beam comprising a desired position of the feed beam;

15 receiving measurement information provided by an inertial measurement unit associated with the feed beam;

estimating, based on the measurement information, movement of the inertial measurement unit associated with the feed beam; and

20 providing, based on the reference position of the feed beam and the estimated movement of the inertial measurement unit, joint control information for controlling a position of the feed beam.

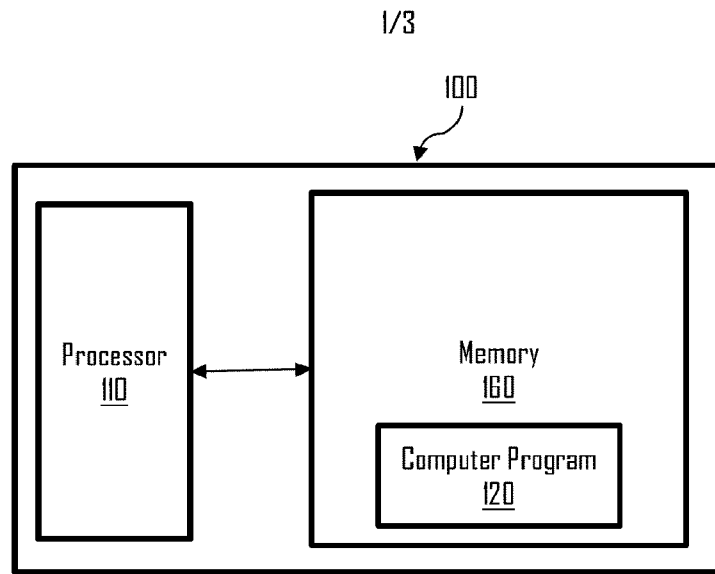

Figure 1

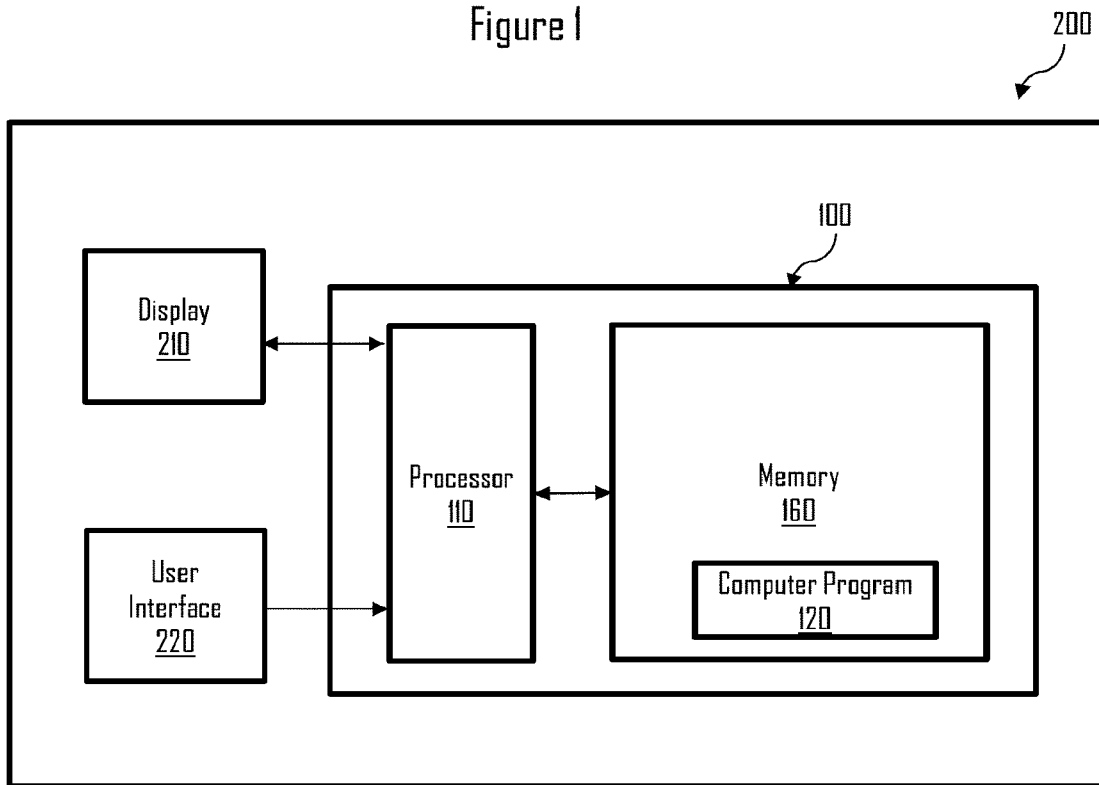

Figure 2

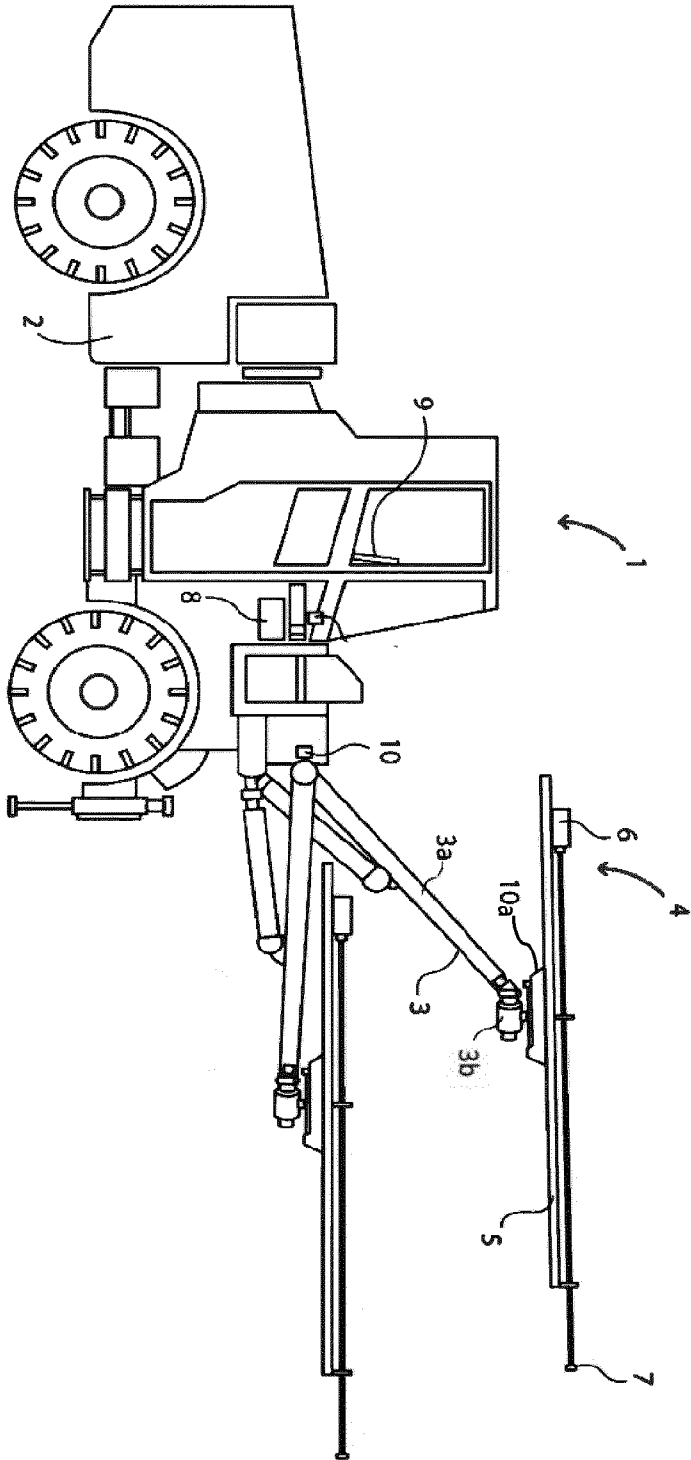

Figure 3

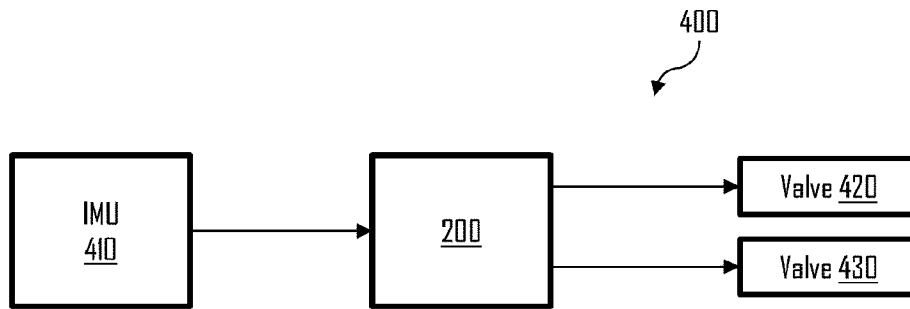

Figure 4

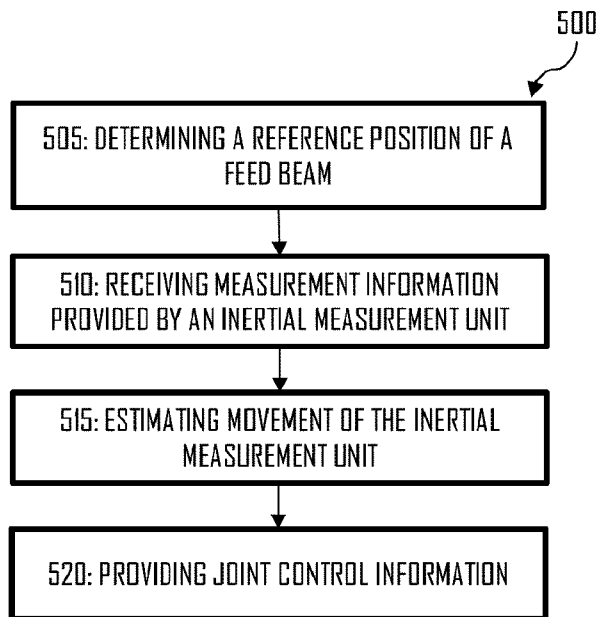

Figure 5

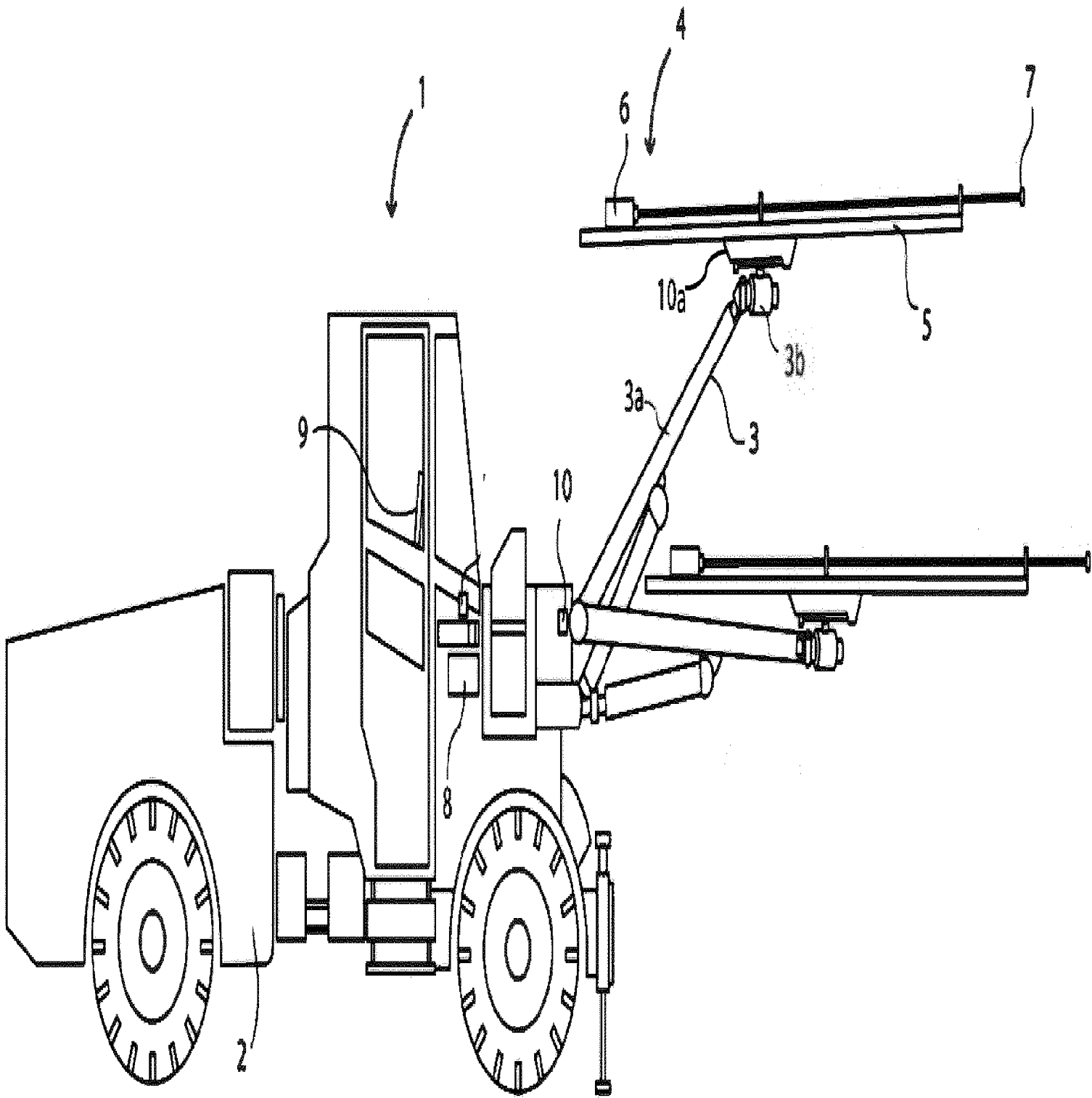

Figure 3